

MOBILE: Placemaking and Community in Mobile Architecture

Joshua John Frick

Contents:

		Written Thesis Document
4-14	MOBILE: Place-making & Community in Mobile Architecture	
15-16		Post-Design Adendum
		Thesis Design Project
17-56	An Itinerant Archaeological Community for Remote Site Exploration	
17-27		Site
28-46		Mobile Archaeology Labs
47-51		Travelling Community Museum
52-56		Presentation Boards

Mobile: Place-making & Community in Mobile Architecture

Introduction

"I saw in their eyes something I was to see over and over in every part of the nation – a burning desire to go, to move, to get under way, anyplace, away from any Here... to move about, free and unanchored, not toward something but away from something. I saw this look and heard this yearning everywhere in every state I visited. Nearly every American hungers to move."¹

Mobile and temporary buildings perform many roles in the built environment, though they have only recently been included within the sphere of architecture.² Impermanence and demountability meet the needs of those who choose or are guided into a mobile lifestyle: show-business and circus performers, members of the military, retirees wishing to see the country, and many others. The relative low-cost and readiness of use draw still more users: those with limited means looking for a home of their own and those displaced by political or religious turmoil or by natural disasters. The aftermath of Hurricane Katrina in the southern United States, and the housing that was provided in the relief efforts are a testament to the poor quality of many of these buildings, irrespective of their design. Mainstream options of mobile dwellings are limited to the various scales of "mobile home" and the attempts at their improvement. A new conception of "mobile home" needs to occur,

recreating it from an understanding of the way of life it intends to house in both functional and poetic terms. What is a mobile architecture for the American way of life?

A truly mobile building holds in its essence the romance of the American West and the ideals of freedom and independence. It holds the independence of the sailing ship and the cross-country motorcycle ride. It is receptive to what brought settlers to our shores in the beginning; the openness of the North American landscape. Mobile buildings are a uniquely, though not exclusively, American architecture.



*The automobile: embodiment of North American ideals & wanderlust.
[Photograph by author]*

This paper will provide a brief exploration of the reasons behind American mobility, the needs that mobile structures are filling in the American landscape, and why a reevaluation of contemporary mobile design is needed. It will explore how a mobile architecture addresses place, home, and community, and examples from vernacular and contemporary architecture will illustrate potential strategies for making mobile design meaningful to its users.

Mobile America

North America is a land of immigrants and wanderers, from the nomadic tribes that first populated it, to the European explorers and political refugees who made their way to its shores, to the families filling covered wagons to reach its western lands. One of the few religious traditions that can be called truly "American" is the Spiritualist Camp and traveling revivals, housed in tents and canopies moving across the landscape.³ The objects and dwellings of a mobile culture – the tipi, the covered wagon, and later the RV and camping trailer - have become icons of freedom and the openness of the North American landscape; they embody much of the spirit of our culture.

Many Americans have adopted a nearly nomadic lifestyle. The U.S. Census Bureau calculates that the typical American will move 11.7 times during their life.⁴ That is an average of one move every five years; more often than anywhere else in the world. Many factors contribute to this mobility: new employment opportunities or a job that requires frequent relocation, a shift from the industrial economy of the "rust belt" to the technological economy of Silicon Valley, even an increase in the divorce rate contribute to the American wanderlust. Perhaps even a genetic inclination toward mobility has been passed from America's first inhabitants and explorers.⁵

Mobile structures have developed as a vernacular of their own,⁶ parallel to that of fixed buildings. They have gained a high level of technical efficiency through the same

process of adaptation and experimentation that generated other vernacular forms, fueled mainly by pragmatic, functional concerns, reducing the experience of the user to a checklist of necessities. They are conceived as mobile and low-cost first and living space second, giving them an air of disposability and poor quality. In the mobile vernacular, "there is still room left... for the poetic."⁷

The mobile home shares its pragmatically-driven construction, as well as its impermanence and economic hierarchical position, with medieval European peasant houses; the simple, wooden structures were easily moved or replaced when land became exhausted or when war loomed.⁸ The house was considered a "movable good" by ancient Germanic law for those who were only allowed to use the surface of land belonging to others.⁹ Wood became a popular building material because of its availability and ease of use. Wooden dwellings began as quickly and crudely built shelters, and were gradually developed from these humble beginnings by craftsmen into the ornate and artful examples that exist within the vernacular landscape. Architects have the opportunity to likewise improve the mobile home and develop it first as a fulfilling place to live, and second as a mobile object.

To make a mobile architecture that is as meaningful to its users as vernacular examples of traditional housing, the building must respond to and be shaped by their way of living, not attempt to mold the users to fit the space.¹⁰ In *House Form and Culture*, Rapoport asserts that the form of the vernacular house of any given culture "is not simply the result of any single causal factor" but is determined by "a whole range of socio-cultural factors seen in their broadest terms."¹¹ These factors do not determine form, but make certain decisions more or less likely as choices are guided by the ideals of the culture in question. "Given a certain climate, the availability of certain materials, and the constraints and capabilities of a given level of technology, what finally decides the form of a dwelling, and moulds the spaces and their relationships, is the vision

that people have of the ideal life.”¹² Henry Glassie writes that “buildings, like poems and rituals, realize culture.”¹³ With a few exceptions, the American housing tradition is mostly assembled from seventeenth and eighteenth century Europe and the mansions of aristocratic dynasties, not from any distinctly American cultural elements.¹⁴ A successful mobile architecture must reflect the culture in question, and the image of the ideal life held by that culture.

Mobile Place

The question must be addressed; can an architecture that truly has no specific site relate itself to place, or is it inherently placeless? Mobile buildings may have more connection to place than their static counterparts, and address place more honestly than a fixed structure; the site is not likely to be greatly changed, but occupied as-is in its natural state. A building can be called “placeless” when it has little to do with the environment around it. Vernacular examples that are specifically tied to a place use building forms intelligently to respond to the forces of nature and relate themselves to the landscape, often making their reaction to the environment an inherent part of their completeness.¹⁵ A mobile building must leave room to respond and adapt itself to a multitude of these forces, which may change drastically as the site changes. Is it, then, even more necessarily linked to the specificity of each place, though each particular place is temporary?

Mobile architecture, in fact, *begins with place*,¹⁶ and the understanding of space and place is tied to motion – we must move within space to gain a sense of it.¹⁷ The “place” of a mobile architecture exists in the concurrence of physical and virtual places, and simultaneously in the past, present, and future.¹⁸ The site that it occupies is informed by memories from the string of past sites that it has departed – taking ideas of orientation, ground forms, wind patterns, how the building rested on the land, views that were available, etc. The present site is incorporated as the learned strategies from

past sites are overlaid onto the current site, making the necessary adaptations to new conditions. Future sites are incorporated in observations of what might be done differently on the next site, and in the way things are packed and unpacked upon arrival and departure. Things are placed with an understanding of how they will be removed, packed with an understanding of how they will need to be unpacked. Mobile architecture combines these real and imagined or remembered qualities into a synthesis of place; it palimpsestically holds all previous sites and all possible future sites within it and superimposes them onto the current site. The object, like Heidegger’s bridge¹⁹, allows for the creation of place (the mobile building is changed just as the site is changed) but does not become a permanent fixture to that place. The place does become a permanent part of the building, and the user. Mobile architecture is not a building that never finds a site, but a building that settles lightly and impermanently upon a site, leaving behind little or no trace of its presence.

Mobile architecture is inherently incomplete; it is in a constant state of becoming as it adapts to new climates and landscapes, and is always somewhere in the process between arrival and departure.²⁰ It is much closer to an organic entity than is a static building; it is in a state of consistent change and adaptation, like vernacular buildings adapting to new cultural and technological needs.²¹ It is inherently cyclical, and requires usability in a variety of climates, meaning the user must be familiar with the cycles of nature to some degree in order to maintain comfort. Perhaps the increased proximity to the cycles of nature and the active shaping of one’s space to react to those cycles has a chance of guiding the user into an intuitive understanding and subsequent respect for the environment around them.²² Thoreau laments that permanent buildings have brought about the loss of human contact with nature, and a mobile building perhaps allows its user to find that “forgotten heaven.”²³ In contemporary buildings, the tendency is to use technology to ignore parts

of the site (climate, topography, geology) and build according to preemptive assumptions of style; to “turn night into day [and] day into a harassed unrest.”²⁴

“Home” is already a fluid concept (people often refer to hotels or campsites as “home” while they travel, constructing “moving images of home” within a temporary framework).²⁵ The term *dwelling* implies temporariness in its original meaning: to pause, to remain in one place, holds the implication of moving on.²⁶ A mobile building becomes a “home-base,” an image of stability and permanence within a moving landscape. Yi-Fu Tuan writes of a child and mother, the mother being a mobile point of familiarity and the child wandering the landscape always within reach of the mother.²⁷ We understand places by the objects that somehow stand out in the landscape and cause us to pause and consider them; without these pauses to create place, a landscape is meaningless.²⁸ The mobile building becomes a moving point that the nomad can identify, and call home; an anchor for time and memory.²⁹ The threshold of a mobile building becomes a critical symbolic component.³⁰ It separates the ever-changing outside world from the familiar inside world, it becomes the physical and psychological anchor for the home, it is the gateway between two worlds. If we are in constant motion, a sense of place becomes impossible,³¹ and a mobile home must pause, even if only for a night; it is *mobile* not *moving*.

Approaches to a Mobile Architecture

American mobility might be seen as a return to a way of living that predates civilization. Robert Kronenburg writes that vernacular examples of mobile buildings “express a sophisticated awareness of the essential characteristics of a sense of place” and respond intelligently to even “harsh and extreme climates using the minimum of materials in the lightest structural form.”³² The fragile balance achieved by nomadic cultures requires a deeper understanding of the land than permanent settlements; they pass

through the land but also must live off it and with it and must understand the natural cycles intimately.³³ The nomad’s world is a series of “places connected by a path.”³⁴ Nomadic cultures do not set a permanent geographic base, although they very often travel within a defined territory,³⁵ as they follow favorable climate or food sources. In a way the American nomads are doing the same thing; following the jobs that provide money to feed and clothe themselves and their families.

The *Siksikaitsitapi* (or Blackfoot Nation)³⁶ lived in a vast territory in the Great Plains area between the Saskatchewan River and the Rocky Mountains,³⁷ with short growing seasons and long bitterly cold winters making a nomadic lifestyle and refined and efficient dwelling a requirement for survival.³⁸ Out of necessity, they strove to achieve and maintain the delicate balance within the environment that humans require for survival. This made it easy to adapt to changes in environment or technology – such as their adoption of the horse brought by European explorers, which replaced the dog as a pack animal.³⁹

The *Siksikaitsitapi* dwelling unit was the iconic *tipi* – with an offset conical shape, and “smoke-flaps” that direct ventilation and create a comfortable interior environment in almost any weather.⁴⁰ The tipi was constructed of wooden poles and a number of tanned buffalo hides, with another layer of tanned hide attached inside as a liner to keep out drafts and moisture while providing ventilation for the fire and some amount of thermal insulation.⁴¹ The smoke-flaps were maneuvered by poles into position to take advantage of breezes and draw out smoke from the interior (the tipi would be oriented to take advantage of the prevailing winds of the area).⁴² The inside of the tipi created space for the daily activities of living: sleeping, eating, cooking, creating tools and artworks, storytelling, playing games, and storage. The single space was divided into smaller areas, and the uses overlapped. Specific spaces were not made for specific functions, allowing an adaptable flexibility of the interior. As with many vernacular buildings

(until the habits of the European aristocracy and their status-symbol-homes began to be imitated), spaces had no specific identity, but were defined by the way they were being used.⁴³

The community of the *Siksikaitsitapi* was arranged into tribes and then into hunting bands,⁴⁴ each camping separately through the warm months and gathering together in the winter and during large ceremonies.⁴⁵ The tribe as a whole had very few laws⁴⁶, and though they had a chief as the leader of the tribe, the political organization was a democratic system in which no one man could decide the fate of the tribe.⁴⁷ Communities were arranged by cooperation and tradition, not under the command of an individual vision.

Although our own expectations of comfort are much higher than those of the *Siksikaitsitapi*, we can learn much from the thought and care put into how a home could be moved from one place to another. We have different technological means, and should learn to take full advantage of them (as the *Siksikaitsitapi* did with the horse) while maintaining (or in our case, first *achieving*) balance with nature.

The contemporary icons of mobile living are the RV, the camping trailer, and the often erroneously named "mobile home".⁴⁸ An entire industry has grown around these factory-made trailers and some models have rather nice appointments, often to the detriment of their mobility.⁴⁹ They are conceived as vehicles that happen to be living space; their mobility is the focus and the experience of the user is merely incidental. Many trailer models betray this by borrowing heavily from the streamlined aesthetics of automobiles and aircraft; they are primarily vehicles, so they look like vehicles.⁵⁰ The outward appearance has nothing to do with its environment or local ways of building.⁵¹ They seem to be ready to move at any time – aside from the addition of wheels, the form does not change when it is in its "mobile mode" – making it difficult visually or psychologically to interpret them as stable objects at any point. They are "impermanent,

transient, low-quality" and "neither tuned to [their] purpose nor appropriate to [their] site."⁵² They bypass professional designers,⁵³ and the typical approach to improving the interior space is to upgrade to a "double" or "triple-wide" - under the assumption that more space means better space. The spaces inside are designed to house specific functions making the flexibility of the interior, the choice of how rooms are used, and the opportunity for self-expression⁵⁴ (especially in fully furnished models) severely limited.⁵⁵ Usually a kitchen/bathroom core separates the sleeping area and the living/dining area; using these spaces for other functions becomes inconvenient at best. This rigidity prevents the trailer from becoming a "self-sufficient, autonomous dwelling," as the uses it cannot contain spill out over the surrounding area in their own structures and areas.⁵⁶

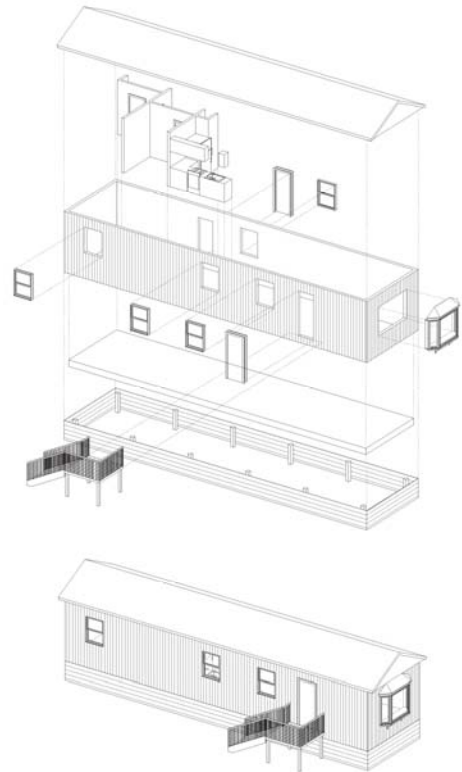

*Exploded Isometric of a Typical Mobile Home (Based on the Fleetwood Weston).
[Illustration by author]*

Often, a mobile home never actually achieves mobility and is trapped in a pseudo-permanence – unable to operate on its own to fulfill the needs of its users, and sacrificing its mobility to solve this problem. The uniform, factory-built mobile home is used as a convenient, prefabricated starting point and then modified over time by attaching more permanent constructions; a gradual accretion of permanence.⁵⁷ The first step is often “skirting”⁵⁸ a mobile home: covering the axles and supports under the trailer by attaching some material as a screen – this can be wooden or plastic-composite lattice, plywood, sheet metal stamped into various patterns, stone, brick, or concrete blocks; nearly anything. Permanent gardens, porches, roofs, or full additional spaces are added as need dictates and finances allow, to create a more complete and individualized home.⁵⁹



*Skirting of mobile homes in various materials.
[Photographs by author]*

Attempts by architects to design for mobile structures are often, like the standard mobile home, designed as vehicles that happen to contain living space. In the 1936 issue of *Architectural Record*, Corwin Willson published his “Mobile House”, which compacted the interior spaces into an 8' x 17.5' footprint; the design was never adopted. The Frank Lloyd Wright Foundation produced a mobilized

version of a Usonian house, mass-produced and made completely site-less.⁶⁰ A popular contemporary tactic for mobility and modularity is reusing metal shipping containers or other convenient objects; taking an object almost symbolic of transportation and adding in living space. Recent interest in mobile housing, in the aftermath of Hurricane Katrina, has amounted to a “better box.”⁶¹ The designs are often a higher-quality, and more expensive, version of mobile home.

Jennifer Siegal's Office of Mobile Design is currently a major force in mobile design, relying on prefabrication and the inherent mobility and economy that it provides. Their Prefab ShowHouse⁶² is a good example of this approach; it is a display home and portable mock-up of the firm's work. The house is constructed of a steel frame built on a standard trailer hitch, with wood and OSB framing between the steel. It is clad in dark-colored metal sheets, reminiscent of a factory-made trailer. The form is similar to a typical trailer, through the roof slopes along its length and overhangs the large windows at one side. The building footprint is a compact twelve feet by sixty feet, and the roof slope measures twelve-and-one-half feet at its top. Window-walls surround the living area, in translucent plastic that keeps out excessive light but gives an introverted-ness to the space. The entrance is placed along the side (like a typical trailer) and is marked by a detachable ramp/porch and a small overhanging roof, celebrating the threshold more than a typical trailer.

The interior space is generous, but each function is very specifically accounted for, leaving little flexibility in the use of the space as a whole, though each area is open enough for some adaptation (more so than typical trailers provide). The kitchen/bathroom core divides the space in to a dining/living area and a sleeping area. The interior furnishings and fixtures are extravagant and unrealistic for many of the users of mobile homes, though they present a high-design ideal for the display-piece home. Interior finishes contain more sustainable materials than the plastics

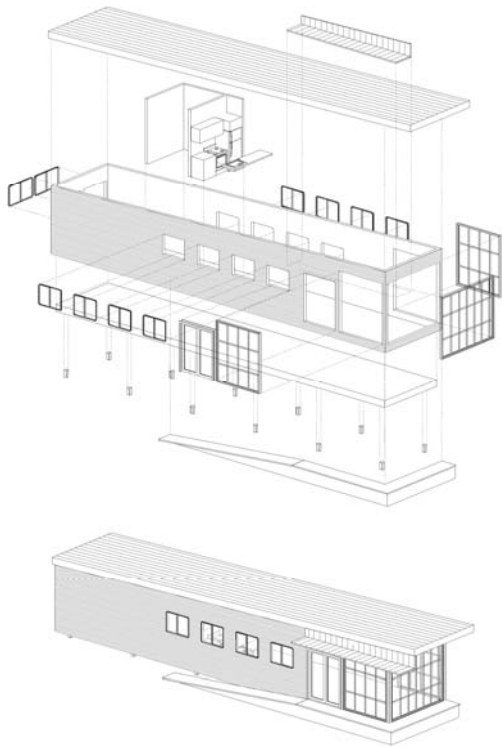

*Exploded Isometric of OMD's ShowHouse.
[Illustration by author]*

and composites found in typical trailers; coconut-palm floors, laminated bamboo woodwork, and Kirei-board panels. Improving the materials solves several problems of a typical trailer – especially the amount of material offgassing, which plagued the disaster-response trailers in New Orleans after Katrina. Tankless water heaters, radiant-heating panels, and roof-mounted photo-voltaic cells are among the green strategies in the design.

The building is transported by semi-truck and deployed onto metal, jack-stand-like stilts, partially skirting these with the ramp/porch. The building changes very little in its mobile mode; the ramp/porch is removed and the small overhang folds up on hinges. This recalls the problem of permanence in typical mobile homes; there is little difference between the home in its stable, provisionally-permanent

state and its state of motion. The ShowHouse is a higher-class of mobile home, giving much needed improvement in the materials and details of a typical trailer and incorporating green design, but ultimately retaining many of the same problems.

If the mobile building embodies freedom and change, then the community to which it belongs should do the same. Most mobile communities have been far too restrictive to allow for that freedom – locking the buildings into grids and burdening them with aesthetic rules to homogenize the community. Mobile structures are grouped together on massive plots of land, usually pushed outside of city limits. A trailer park is essentially a micro-scaled suburb, sharing many of the problems of suburban sprawl. One can find countless “right” answers to the problems created by the suburban condition; I do not wish to posit another, but highlight the error in emulating a flawed system.

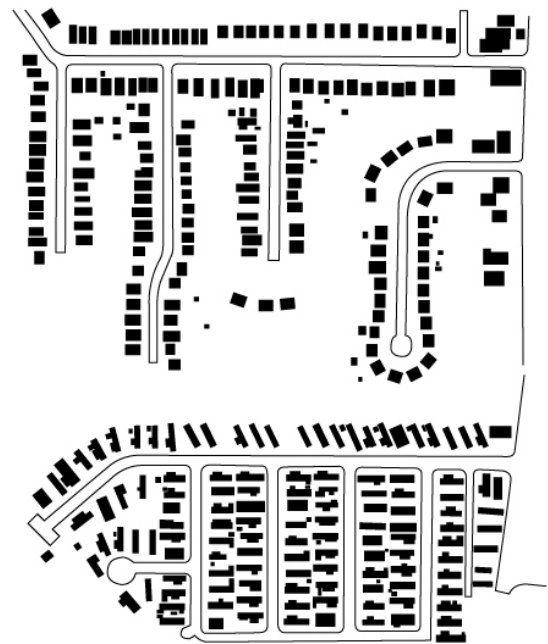

*Comparison of suburb near Cincinnati, OH (top)
and trailer park near Oxford, OH (bottom).
[Illustration by author]*

The codes and laws that govern mobile structures should be as adaptable as the structures themselves, like the politics of the *Siksikaitsitapi*; not exclusive, but grounded in the "cultivation of possibility."⁶³ Success cannot be expected by using only mobile buildings within a standard community layout, or by adapting communities to the mass-produced trailer (as in Paul Rudolf's "Trailer Tower", Archigram's "Plug-in City", and Moshe Safdie's "Habitat" for the 1967 Montreal Expo). The building and the community must be grown, as in the vernacular tradition, from the users' way of life, and they must contain enough diversity (as is the case with any organism) to allow the community to thrive. It cannot simply group together all of the mobile dwellings and separate them from the rest.

Conclusion

A mobile building should be designed accepting its mobility and accounting for the full experience of the space by the user. It should not favor mobility over comfort, poetic content, or quality, but be open to mobility while creating meaningful space within those parameters. Though it is not permanent on a site, it is the permanent place of its user. It should adapt to both changing climate and changing uses, and allow the user to make adjustments to their environment as they see fit. This allows for the user to appropriate the space (prerequisite for dwelling) and the building to respond to its environment and reflect its current place (in a way similar to vernacular structures). It should be a true *home*; an anchor point for the user and their memories as they move through the landscape, the familiar point that calls place into being and allows part of the self to be reflected. To do this, the user should be able to distinguish a difference in its mobile and static forms. It must "acknowledge both the sheltering power of place and the indefinite promise of open space."⁶⁴ It must communicate not only that it has ceased moving, but that it is a stable and permanent entity that enables dwelling, not a disposable object – *mobile* but not temporary.

Notes

- 1 John Steinbeck, *Travels With Charlie: In Search of America* (New York: Viking Press, 1961) p. 10.
- 2 Robert Kronenburg, *Portable Architecture: Design and Technology* (Basel, Switzerland: Birkhauser Verlag AG, 2008) p. 8.
- 3 Charlie Hailey, *Campsite: Architectures of Duration and Place* (Baton Rouge, LA: Louisiana State University Press, 2008) p. 63-67.
- 4 Kristin A. Hansen, "Geographical Mobility," *U.S. Census Bureau: Population Profile of the United States*, <http://www.census.gov/population/www/pop-profile/geomob.html> (accessed June 16, 2010).
- 5 Dr. Fred Goodwin. August 2001. "Why Do Americans Move So Often": interview with Dr. Goodwin. By Steven Frazier. CNN, <http://transcripts.cnn.com/TRANSCRIPTS/0108/05/sun.10.html> (accessed June 16, 2010).
- 6 John Brinckerhoff Jackson, *Discovering the Vernacular Landscape* (New Haven, CT: Yale University Press, 1984) p. 101. & *A Sense of Place, A Sense of Time*, p. 64.
- 7 Martin Heidegger, "Poetically Man Dwells" in *Rethinking Architecture: A Reader in Cultural Theory*, Neil Leach ed. (New York: Routledge, 1997) p. 110.
- 8 Jackson notes that as historical evidence is being gathered about medieval Europe, the myth of a peasant family farming a plot of land for many generations is gradually being replaced by a more temporary and mobile farming tradition. Jackson, *Discovering the Vernacular Landscape*, p. 94.
- 9 Jackson, *Discovering the Vernacular Landscape*, p. 51.
- 10 Karsten Harries, *The Ethical Function of Architecture* (Cambridge, MS: The MIT Press, 1997) p. 149.
- 11 Amos Rapoport, *House Form and Culture* (Upper Saddle River, NJ: Prentice-Hall, Inc., 1969.), p. 47.
- 12 Rapoport, *House Form and Culture*, p. 47

- 13 Henry Glassie, *Vernacular Architecture* (Bloomington, IN: Indiana University Press, 2000) p. 17.
- 14 Jackson, *Discovering the Vernacular Landscape*, p. 92-93.
- 15 Jackson, *A Sense of Place, A Sense of Time*, p. 67.
- 16 Hailey, *Campsite*, p. 1.
- 17 Yi-Fu Tuan, *Space and Place, : The Perspective of Experience* (Minneapolis, MN: University of Minnesota Press, 1977) p. 19-33 & 118.
- 18 Hailey, *Campsite*, pp. 33 & 71.
- 19 Martin Heidegger, "Building, Dwelling, Thinking" in *Rethinking Architecture: A Reader in Cultural Theory*, Neil Leach ed. (New York: Routledge, 1997) p. 104-106.
- 20 Hailey, *Campsite*, p. 9.
- 21 Hailey, *Campsite*, p. 34.
- 22 Jackson sites an unnamed ancient agricultural handbook as stating that, "The farmer should study the nature of the land from which he expects to make a living...For just as every man and every animal has his own peculiarities, every field has its own nature." Jackson, *Discovering the Vernacular Landscape*, p. 54.
- 23 Henry David Thoreau, *Walden* (Princeton: Princeton University Press, 2004), 29 & 113.
- 24 Heidegger, "Building, Dwelling, Thinking," p. 103.
- 25 Hailey, *Campsite*, p. 13, 30, & 114.
- 26 Jackson, *Discovering the Vernacular Landscape*, p. 91. and Heidegger, "Building, Dwelling, Thinking," p. 101.
- 27 Tuan, *Space and Place*, p. 29.
- 28 Tuan, *Space and Place*, p. 161
- 29 Tuan, *Space and Place*, p. 187.
- 30 Hailey, *Campsite*, p. 21.
- 31 Tuan, *Space and Place*, p. 179.
- 32 Robert Kronenburg, *Houses in Motion: The Genesis, History and Development of the Portable Building* (Chichester, West Sussex: Wiley-Academy, 1995) p. 11.
- 33 Kronenburg, *Houses in Motion*, p. 17.
- 34 Yi-Fu Tuan, *Space and Place*, p. 182.
- 35 Kronenburg, *Houses in Motion*, p. 17.
- 36 The Blackfoot nation is a group of four related tribes, all using the same language. It is made up of the South Peigan (*Aamsksaapiikani*), the North Peigan (*Aapatohsipiikani* or *Skinnii Piikani*), the Blood (*Kainai* or *Aapaitsitapi*), and the Blackfoot (*Siksikaitsitapi*). Betty Bastien, *Blackfoot Ways of Knowing: The Worldview of the Siksikaitsitapi* (Calgary, Alberta, Canada: University of Calgary Press, 2004) p. 9.
- 37 Bastien, *Blackfoot Ways of Knowing*, p. 9.
- 38 John C. Ewers, *Blackfeet Indians: Ethnological Report on the Blackfeet and Gros Ventre Tribes of Indians*. (New York: Garland Publishing Inc., 1974.) p. 33.
- 39 Bastien, *Blackfoot Ways of Knowing*, p. 11-13.
- 40 Reginald & Gladys Laubin, *The Indian Tipi: Its History, Construction, and Use* (Norman, OK: University of Oklahoma Press, 1977) p. 3.
- 41 Laubin, *The Indian Tipi*, p. 23 & 57.
- 42 Laubin, *The Indian Tipi*, p. 37.
- 43 Jackson, *A Sense of Place, A Sense of Time*, p. 65.
- 44 James Willard Schultz, *Recently Discovered Tales of Life Among the Indians* (Missoula: Mountain Press Publishing Company, 1988) p. 27.
- 45 The *Siksikaitsitapi* words for summer and winter – which is how they divide the year – are *na-pos* and *sto-ye*, meaning "open" and "closed" respectively.
- 46 Schultz, *Recently Discovered Tales of Life Among the Indians*, p. 29.

- 47 Ewers, *Blackfeet Indians*, p. 40.
- 48 Charles W. Moore, Kathryn Smith, and Peter Becker, *Home Sweet Home: American Domestic Vernacular Architecture* (New York: Rizzoli International Publications, 1983) p. 49.
- 49 Moore, Smith, and Becker, *Home Sweet Home*, p.139.
- 50 Though this may be appropriate and honest visually, the initial conception as a vehicle interferes with its function as a living space. As Umberto Eco writes, "The principle that form follows function might be restated: the form of the object must, besides making the function possible, denote that function clearly enough to make it practicable as well as desirable, clearly enough to dispose one to the actions through which it would be fulfilled."
Umberto Eco, "Function and Sign: The Semiotics of Architecture" in *Rethinking Architecture: A Reader in Cultural Theory*, Neil Leach ed. (New York: Routledge, 1997) p. 182.
- 51 Jackson, *A Sense of Place, A Sense of Time*, p. 60. And Harries, *The Ethical Function of Architecture*, p. 144.
- 52 Kronenburg, *Houses in Motion*, p. 9.
- 53 Kronenburg, *Houses in Motion*, p. 11.
- 54 Harries writes that the appropriation of a space is essential for a house to become a home, later referencing Heidegger's statement that "mortals... must ever learn to dwell."
Harries, *The Ethical Function of Architecture*, p. 147 & 165.
- 55 Jackson, *A Sense of Place, A Sense of Time*, p. 60-64.
- 56 Jackson, *A Sense of Place, A Sense of Time*, p. 60.
- 57 This I can attest to personally. The first eighteen years of my life were spent in a mobile home – not placed in a mobile home park, but secluded in rural West Virginia - onto which had been added an asphalt-shingled roof, a wooden porch, three additional wood-framed rooms, and a concrete block faux-foundation. The initial purchase of the trailer home was meant to be a temporary stand-in until a more permanent home could be built. As conditions changed, the permanent home grew up around the temporary one.
- 58 Hailey, *Campsite*, p. 111.
- 59 Harries asserts that these additions anchor the mobile home to the site, because dwelling in a mobile building is impossible; "roots" are needed to make any sense of place possible. I argue that they are an attempt to correct the anonymity of a poorly mass-produced building, not that place-making is somehow bound and immobile.
Harries, *The Ethical Function of Architecture*, p. 147.
- 60 Hailey, *Campsite*, p.72.
- 61 Hailey, *Campsite*, p. 209.
- 62 Information for the ShowHouse and the accompanying illustration was gathered from Jennifer Siegal's *More Mobile: Portable Architecture for Today*, and OMD's website, www.designmobile.com.
- 63 Hailey, *Campsite*, p. 7.
- 64 Harries, *The Ethical Function of Architecture*, p. 175.
-

Bibliography

- Bastein, Betty. *Blackfoot Ways of Knowing: The Worldview of the Siksikaitsitapi*. Calgary, Alberta, Canada: University of Calgary Press, 2004.
- Cowgill, Donald Olen. *Mobile Homes: A Study of Trailer Life*. Philadelphia, PA: University of Pennsylvania, 1941.
- de Certeau, Michel. *The Practice of Everyday Life*. Los Angeles, CA: University of California Press, 1984.
- Echavarria M., Pilar. *Portable Architecture and Unpredictable Surroundings*. Barcelona, Spain: LINKS International, 2006.
- Ewers, John C. *Blackfeet Indians: Ethnological Report on the Blackfeet and Gros Ventre Tribes of Indians*. New York: Garland Publishing Inc., 1974.
- Glassie, Henry. *Vernacular Architecture*. Indianapolis, IN: Indiana University Press, 2000.
- Hailey, Charlie. *Campsite: Architectures of Duration and Place*. Baton Rouge, LA: Louisiana State University Press, 2008.
- Harries, Karsten. *The Ethical Function of Architecture*. Cambridge, MS: The MIT Press, 1997.
- Holl, Steven. *Anchoring*. New York: Princeton Architectural Press, 1989.
- Jackson, John Brinckerhoff. *A Sense of Place, a Sense of Time*. New Haven, CT: Yale University Press, 1994.
- Jackson, John Brinckerhoff. *Discovering the Vernacular Landscape*. New Haven, CT: Yale University Press, 1984.
- Kronenburg, Robert. *Houses in Motion: The Genesis, History, and Development of the Portable Building*. West Sussex: Wiley-Academy, 1995.
- Kronenburg, Robert. *Portable Architecture: Design and Technology*. Basel, Switzerland: Birkhauser Verlag AG, 2008.
- Laubin, Reginald and Gladys. *The Indian Tipi: Its History, Construction, and Use*. Norman, OK: University of Oklahoma Press, 1977.
- Leach, Neil. *Rethinking Architecture: A Reader in Cultural Theory*, Neil Leach ed. New York: Routledge, 1997.
- Levi-Strauss, Claude. *The Way of the Masks*. Seattle: University of Washington Press, 1982.
- Moore, Charles W., Kathryn Smith, and Peter Becker. *Home Sweet Home: American Domestic Vernacular Architecture*. New York: Rizzoli International Publications, 1983.
- Rapoport, Amos. *House Form and Culture*. Upper Saddle River, NJ: Prentice-Hall, Inc., 1969.
- Schultz, James Willard. *Recently Discovered Tales of Life Among the Indians*, ed. Warren L. Hanna. Missoula: Mountain Press Publishing Company, 1988.
- Siegal, Jennifer. *Mobile: The Art of Portable Architecture*. New York: Princeton Architectural Press, 2002.
- Siegal, Jennifer. *More Mobile: Portable Architecture for Today*. New York: Princeton Architectural Press, 2008.
- Steinbeck, John. *Travels With Charlie: In Search of America*. New York: Viking Press, 1961.
- Tuan, Yi-Fu. *Space and Place: The Perspective of Experience*. Minneapolis, MN: University of Minnesota Press, 1977.

Adendum: Post-Design

The written portion of this thesis was sparked by an inquiry into my own assumptions about mobile and temporary architecture; mainly that if a building is mobile it cannot fully address or create place and hinders the formation of a stable community. I felt that this statement applies to much of our current mobile architecture, and especially to the “mobile home,” but could not say the same about vernacular examples of mobile building – such as the tipi, the yurt, and even the Gypsy caravan. I chose to explore why this was the case.

After setting up at least some level of argument for a mobile architecture that has the possibility to address place and allow community through the written thesis, it was time to test the ideas in a design project. The selection of a use type required much thought and deliberation (perhaps too much); almost anything can be mobilized. I wished to find a program that could benefit from being made mobile or that already had an element of mobility that could be improved, and had programmatic elements in addition to the housing type which made up most of my written inquiry. For this I eventually chose archaeology.

As the project developed, it became a kind of balancing act to find the appropriate level of perceived mobility. In other words, the building would be mobile but it should not look overtly mobile or temporary. This was relatively easy to gauge; as I sought outside opinions on the work, something too visually mobile would be met with comparisons (carrying negative connotations) of pop-up trailers or camping/military tents. The final design is the result of slowly paring away these overtly mobile appearances while maintaining an easily deployable and removable structure. The mechanical operations of the buildings are assembled from already existing and tested technologies – hydraulic cylinders from heavy construction equipment for the extending legs,

nested shells on wheeled tracks from rigid pool or stadium covers for the main envelope of the building, cooking and hygiene tactics used in some of our current mobile buildings. The form of the building grew largely from the operation required to pack it away, and attempting to guide them into an ordered and visually interesting sequence.

The design has been tested most deeply on a single site, though the site chosen was intentionally most challenging climatically and topographically. I am confident that with the level of flexibility built into the design, other sites or climates would not pose a problem for the functioning of the building. The strategies which were formed in this project are not necessarily limited to the archaeological program, and with some adaptation could be applied to disaster-relief programs, mobile medical clinics, and many other mobile use types. With a change in the way the buildings are arranged on the site (by placing the buildings parallel to one another, blocking views by adjacent shared walls in this way -]]]) they could also be adapted easily into a new kind of truly mobile home and community that would be a vast improvement over the current trailer park typology and even perhaps the typical suburban layout.

I chose to add a second building type to the program – the traveling museum – to mediate the tendency of the archaeological process to seem closed and exclusory. The hope is that by allowing the community into which the archaeologist have placed themselves to view the archaeological process, some level of transparency could be achieved. A connection could be made between the existing community in the area, the ancient community which is being researched, and the itinerant archaeological community being housed in my design; perhaps by this layering something new could be learned.

Design Bibliography

Balme, Jane & Alistar Paterson. *Archaeology in Practice: A Student Guide to Archaeological Analysis*. Malden, MA: Blackwell Publishing Ltd, 2006.

Berger, Horst. *Light Structures, Structures of Light: The Art and Engineering of Tensile Architecture*. Basel, Switzerland: Birkhäuser Verlag, 1996.

Burke, Heather, Claire Smith, & Larry J. Zimmerman. *The Archaeologist's Field Handbook: North American Edition*. Lanham, MD: AltaMira Press, 2009.

Champion, Sara. *A Dictionary of Terms and Techniques in Archaeology*. New York: Facts on File, Inc., 1980.

Cook, Peter, Dennis Crompton, David Greene, Ron Herron, Michael Webb (ARCHIGRAM); Toni Stooss & Elanora Louis (Kunstalle Wien). *A Guide to ARCHIGRAM 1961-74*. London: Academy Group Ltd, 1994.

Cook, Peter, Dennis Crompton, David Greene, Ron Herron, Michael Webb (ARCHIGRAM). *ARCHIGRAM*. New York: Books That Matter, 1973.

Dancey, William S. *Archaeological Field Methods: An Introduction*. Minneapolis, Minnesota: Burgess Publishing Company, 1981.

Dent, Roger N. *Principles of Pneumatic Architecture*. London: The Architectural Press, 1971.

Dessauce, Marc. *The Inflatable Moment: Pneumatics and Protest in '68*. New York: Princeton Architectural Press, 1999.

Drew, Philip. *New Tent Architecture*. New York: Thames & Hudson Inc, 2008.

Freeman, Michael. *Space: Japanese Design Solutions for Compact Living*. New York: Universe Publishing, 2004.

Herzog, Thomas. *Pneumatic Structures: A Handbook of Inflatable Architecture*. New York: Oxford University Press, 1976.

Ishii, Kazuo. *Structural Design of Retractable Roof Structures*. Boston, MA: WIT Press, 2000.

Oka, Hideyuki. *How to Wrap Five Eggs: Traditional Japanese Packaging*. Boston, MA: Weatherhill Publishing, 2008.

Pearson, David. *The House That Jack Built: Circle Houses: Yurts, Tipis, and Benders*. White river Junction, Vermont: Chelsea Green Publishing Company, 2001.

Schwartz-Clauss, Mathias & Alexander von Vegesack. *Living in Motion: Design and Architecture for Flexible Dwelling*. Weil am Rhein: Vitra Design Museum, 2002.

Shaeffer, R.E. *Tensioned Fabric Structures: A Practical Introduction*. New York: American Society of Civil Engineers, 1996.

Case Studies and Influences

Marlon Blackwell Architect. *Dragonfly House*. Fayetteville, Arkansas.

Office of Mobile Design. *Prefab Showhouse*, Venice, California.

Fleetwood Homes. *The Weston Mobile Home*, Riverside, California.

Felipe Campolina. *Portability Housing*, Belo Horizonte, Brazil.

Hugh Broughton Architects. *Halley VI Antarctic Research Station*, Brunt Ice Shelf, Antarctica.

Horden Cherry Lee London. *Micro-Compact Village*, London.

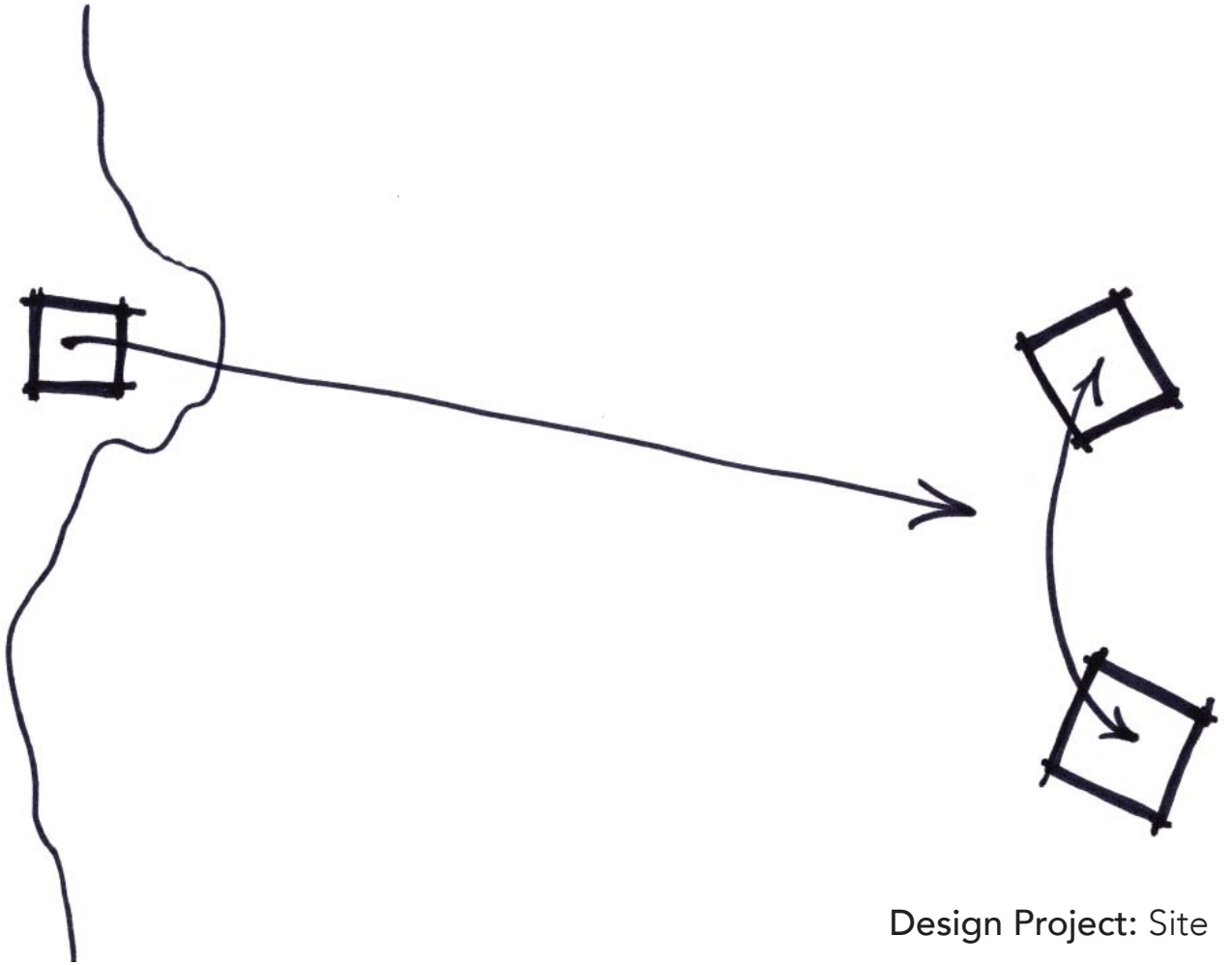

Design Project: Site

Choosing a site for a mobile project may seem at first counterintuitive, but given my conviction in the written thesis that a mobile building should respond to its site, a real-world place was chosen. Initially, I looked for sites that seemed to have a potential for archaeological content but hadn't been explored. Later I decided to use a site which had recently been excavated and processed in order to be grounded by realistic parameters such as locations of dig sites, found artifacts, crew size, timeline, etc. I decided that an additional program element would be added: a mobile museum component that would display some of the artifacts that were found on the site and educate any curious members of the existing community about what exactly this group of researchers were doing on what would effectively be "their land." The hope is that this would provide a level of transparency to the archaeological process, and connect the permanent existing community of the site with the itinerant community of the archaeologists. I chose to use a site near Cortez, Colorado called the Woods Canyon Pueblo which was studied by the Crow Canyon Archaeological Center between 1994 and 1999. The CCAC is gracious enough to publish all of their documentation in an online database, which allowed me to gain a very deep understanding of the site.

SPACES

Surveying

- Residential
- Tool storage
- Small artifact storage
- Work area/office

Excavation

- Residential +
- Work area/office +
- Tool storage +
- Artifact storage +
- Temporary tent-like or tarp-like structures
- Educational/community component

Processing

- Residential +
- Work area/office +
- Tool storage
- Artifact storage
- Temporary tent-like or tarp-like structures
- Educational/community component
- Work areas for specialists

EQUIPMENT

Surveying

- GPS units
- Clicker-counters
- Tape measures
- Flags
- Collection bags
- Tags
- Transit level
- Worktables
- Geophysical testing equipment
- Magnetometry equipment

Excavation

- Transit level
- Drawing boards
- Worktables +
- Shovels
- Large picks
- Small picks
- Trowels
- Wheelbarrow
- Buckets and boxes
- Water tanks
- Shading devices

Processing

- Specialty equipment for processing
- Water tanks +
- Drawing boards
- Worktables +



EXPRESSION OF MOBILITY

Residences	
Work Areas	
Storage	
Educational Component	
Specialist Areas	
Dig Tents	
Drop-off	
Modular	
Fold-out	
Tensile	
Pneumatic	

ARCHAEOLOGY CREW

Field-walking

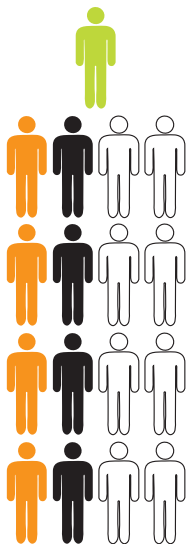

Sensing



Excavation



Finds-processing



- Site Supervisor
- Sensing Specialists
- Finds Specialists
- Outside Help/Students



TOOLS & EQUIPMENT

ARCHAEOLOGICAL PROCESS

SURVEYING

The site is measured and divided into a grid that helps order the rest of the process. Field-walking determines the initial boundaries of a dig site by finding clusters of surface artifacts. The site is then surveyed and analysed through magnetometry to find the most likely excavation spots.



EXCAVATION

Following the grid, areas are marked out and excavated layer by layer, carefully documenting every instance of "human action" that has taken place on the site. Later, all of the removed soil is processed further for small artifacts.



PROCESSING

Artifacts are analysed and catalogued to assemble an understanding of the history of the site. Because the two phases often overlap, more processing occurring in the field means a better understanding and therefore a more educated excavation.



TESTING

Experts in various fields (pottery, metals, bones, etc) analyse the finds, date the artifacts, and assemble a timeline of the site. As with processing, the information gathered in this phase can inform further excavation.



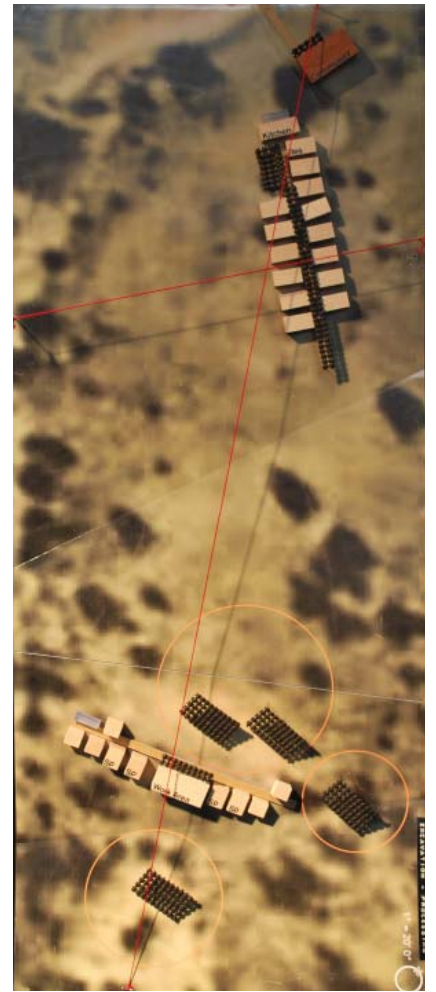
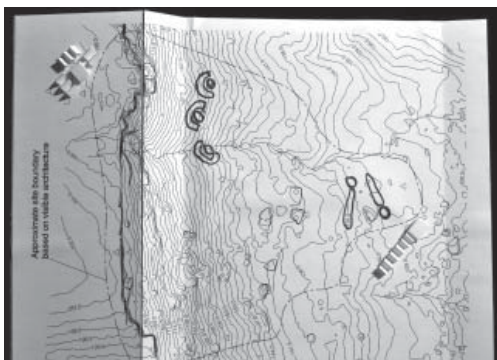
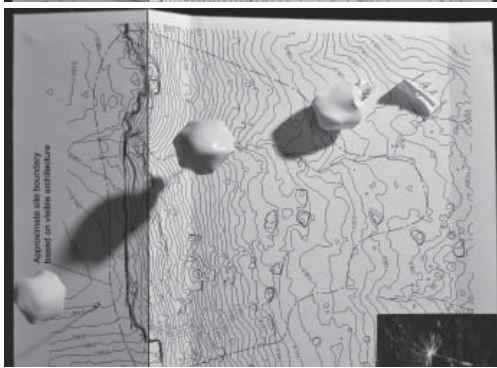
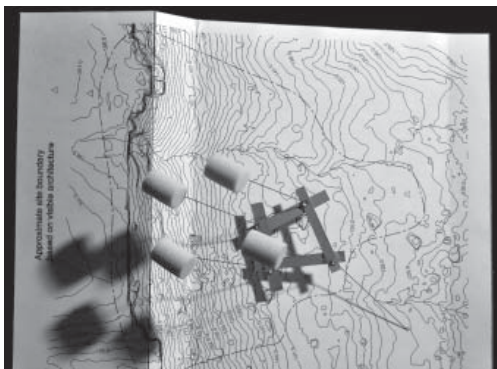
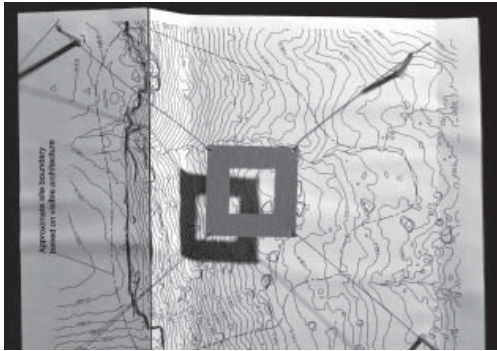
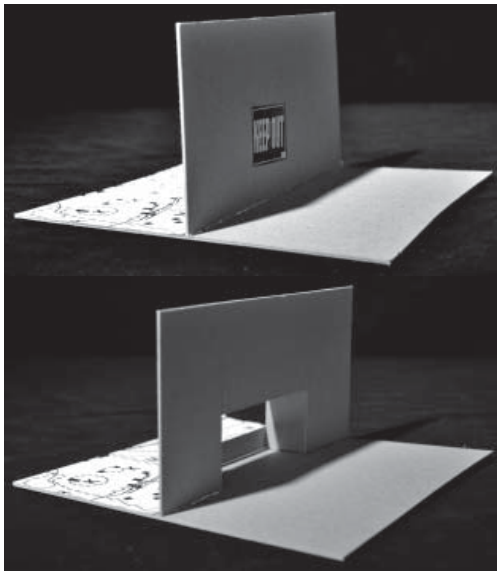

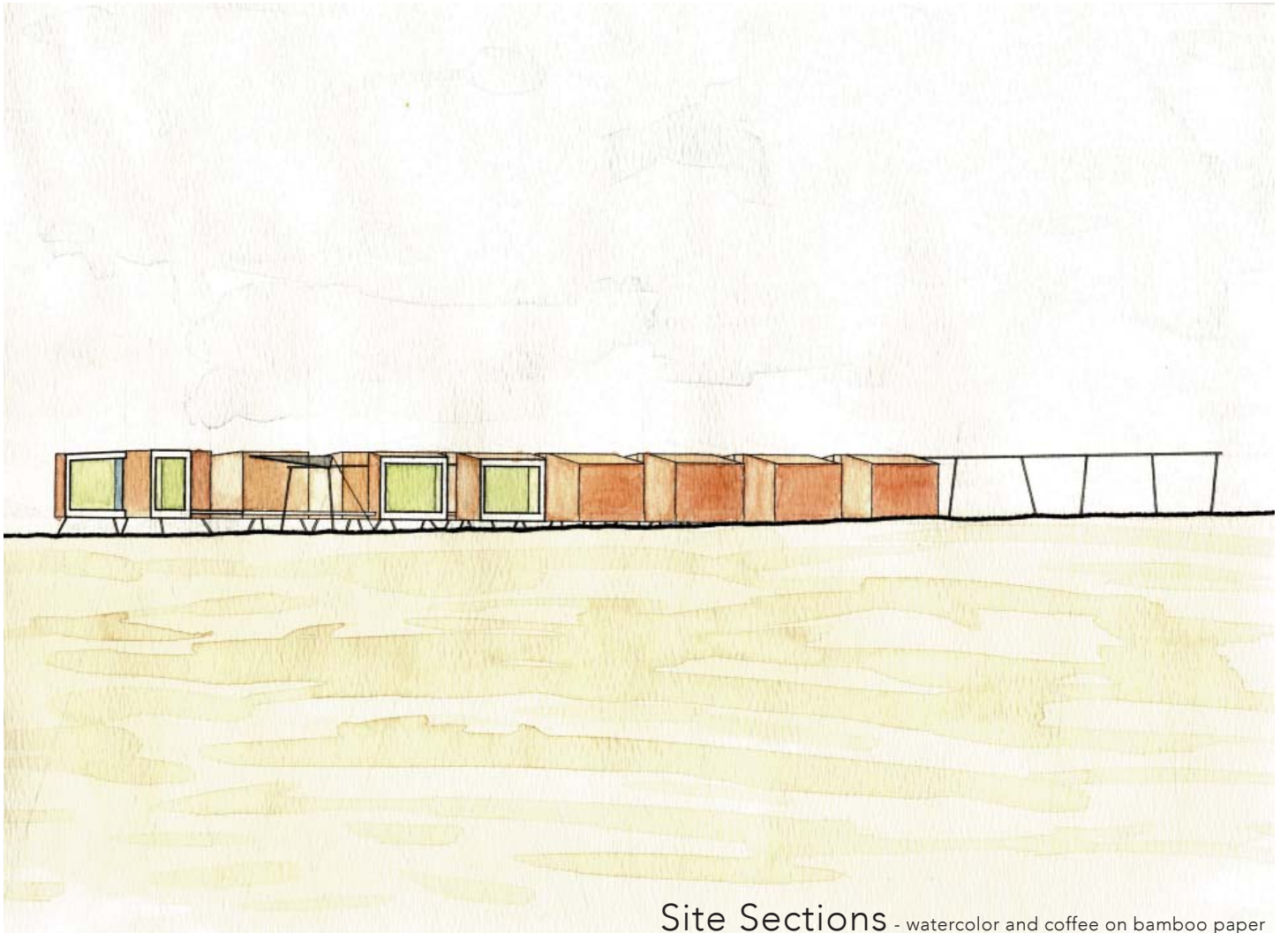
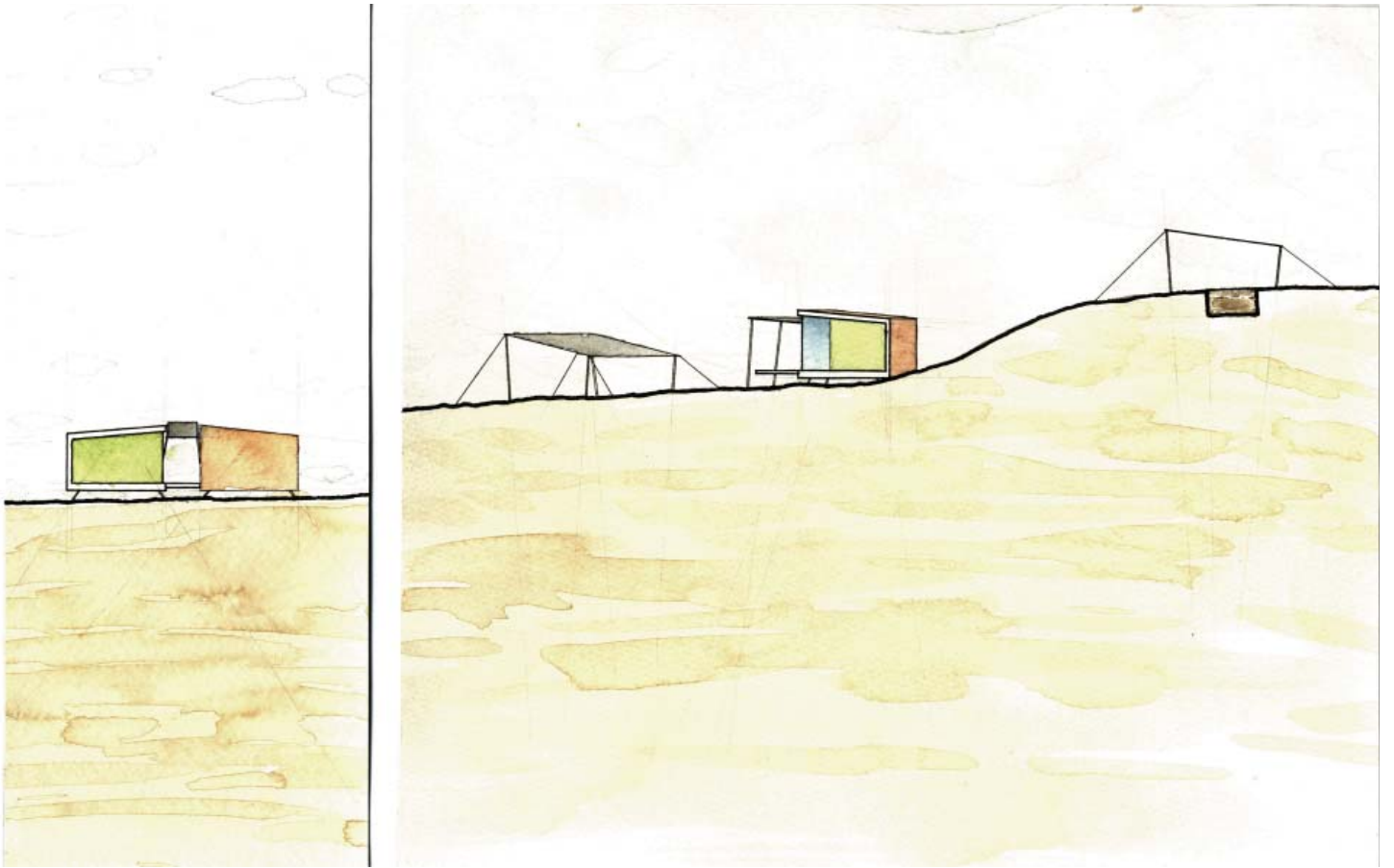

Site Sections - watercolor and coffee on bamboo paper

KITCHENER, ONTARIO

ARCHAEOLOGICAL DATA:

A few hundred people lived in long houses, made pottery and grew corn in a medium-sized village on the banks of Straburg Creek that was thriving 100 years before Samuel de Champlain set foot in Ontario.

The remains of at least 10 long houses, including one 90 metres long, ancient piles of garbage, pieces of pottery, pipes, spear tips and arrowheads have been found. A short distance away from the main village, archeologists found summer houses where corn was grown.

First Nations in the Grand River watershed did not start living in villages until about 1,000 years ago, "so you don't get a lot of them," Facher said.

Some of the artifacts are about 500 years old. Others go back 4,500 years and the oldest is estimated at 9,000 years old.

CLIMATE:

High Temperature:	99° F
Low Temperature:	-25° F
Total Precipitation:	30"
Total Snowfall:	52"
Days Above 90° F:	4
Days Above 65° F:	128
Days Below 32° F:	146
Days Below 5° F:	20
Weather Concerns:	Blizzards, freezing temperatures



ESTERO BAY, FLORIDA

ARCHAEOLOGICAL DATA:

A remnant of one of the rarest cultural landscapes in North America, the water world of the Calusa Indians and their Precolumbian ancestors, a people whose fishing prowess puts modern anglers to shame.

Shell middens (ancient refuse piles) mark the former locations of Indian houses, some likely built on pilings above Estero Bay. Artificial canals, now clogged with mangroves, once led from the shallow waters of the bay into the village and what are thought to be canoe basins—parking lots for dugouts. A larger canal cuts into the heart of this Precolumbian Venice. In the sixteenth century, this was Calos, a vibrant Native American town of several hundred people.

There are dozens of similar sites along a section of the southwestern Florida coast. From A.D. 800 into the seventeenth century this coast was dominated by the Calusa (said to mean "the fierce people" in their language). Though archaeologists have long known about the Calusa, it's only in the last three decades that modern investigators have begun to unravel the secrets of these native peoples and their ancestors.

CLIMATE:

High Temperature:	100° F
Low Temperature:	20° F
Total Precipitation:	48"
Total Snowfall:	-
Days Above 90° F:	49
Days Above 65° F:	247
Days Below 32° F:	2
Days Below 5° F:	-
Weather Concerns:	Hurricanes, heavy rains, flooding

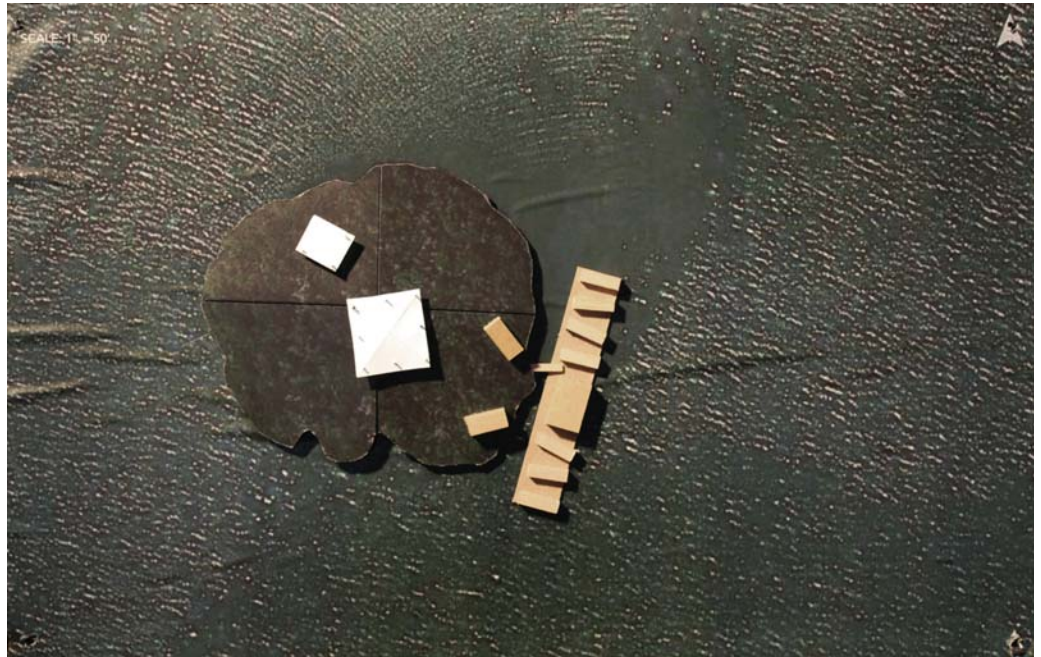

CORTEZ, COLORADO

ARCHAEOLOGICAL DATA:

In 2011, the Crow Canyon Archaeological Center will begin a new research project to examine early Pueblo community development in the Mesa Verde region.

Titled the Basketmaker Communities Project: Early Pueblo Society in the Mesa Verde Region, this new study will shed light on a pivotal, but under-investigated and poorly understood, time in Pueblo history: the Basketmaker III period (A.D. 500–750). The centerpiece of the project is the Dillard site (5MT10647), a Basketmaker III ceremonial center that dates from the seventh century A.D. and includes a great kiva.

Three years of fieldwork are planned. In addition to conducting test excavations at the Dillard site, we will also undertake intensive excavations at a number of pithouse sites in the surrounding area that date to the same time period as the Dillard site. Together, these settlements constitute the most extensive and best-preserved Basketmaker III community known in the central Mesa Verde region.

CLIMATE:

High Temperature:	100° F
Low Temperature:	-31° F
Total Precipitation:	13"
Total Snowfall:	39"
Days Above 90° F:	58
Days Above 65° F:	85
Days Below 32° F:	145
Days Below 5° F:	4
Weather Concerns:	Harsh sun, cold winter, dry conditions



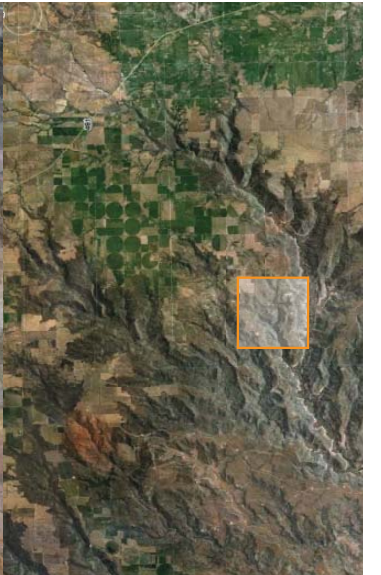
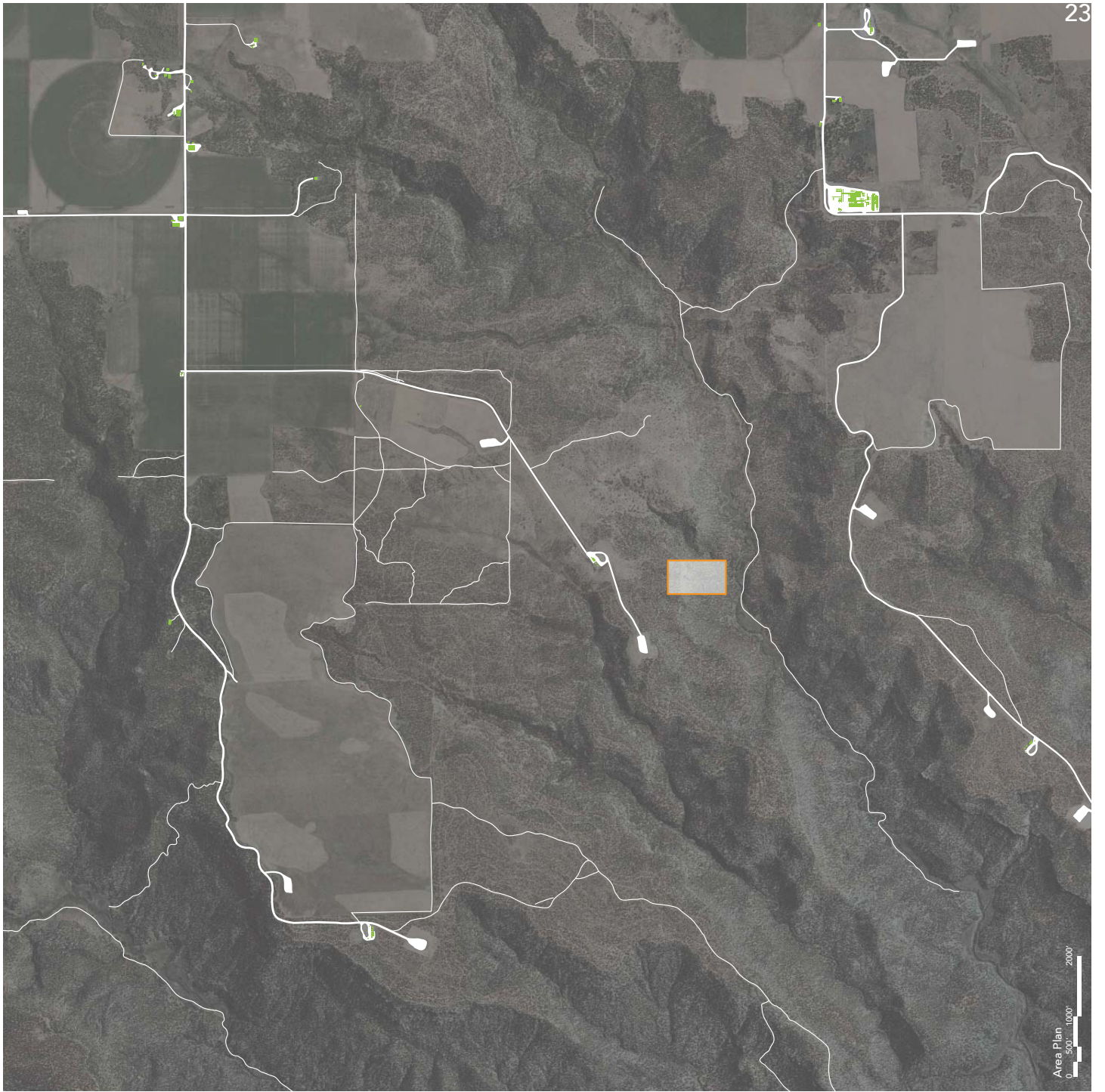

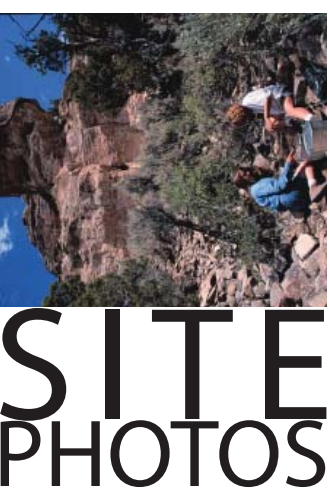
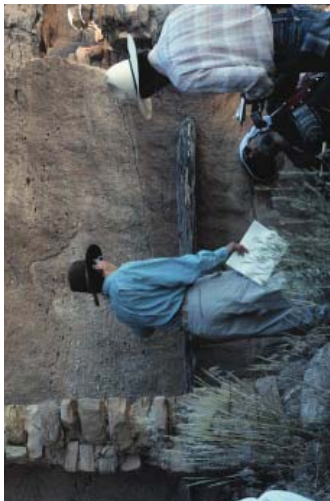
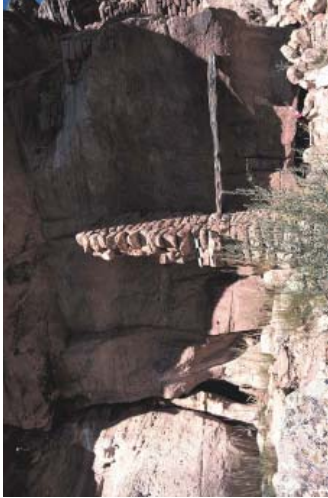

SITE PHOTOS

Photographs courtesy of the Crow Canyon Archaeological Center - Cortez, CO.

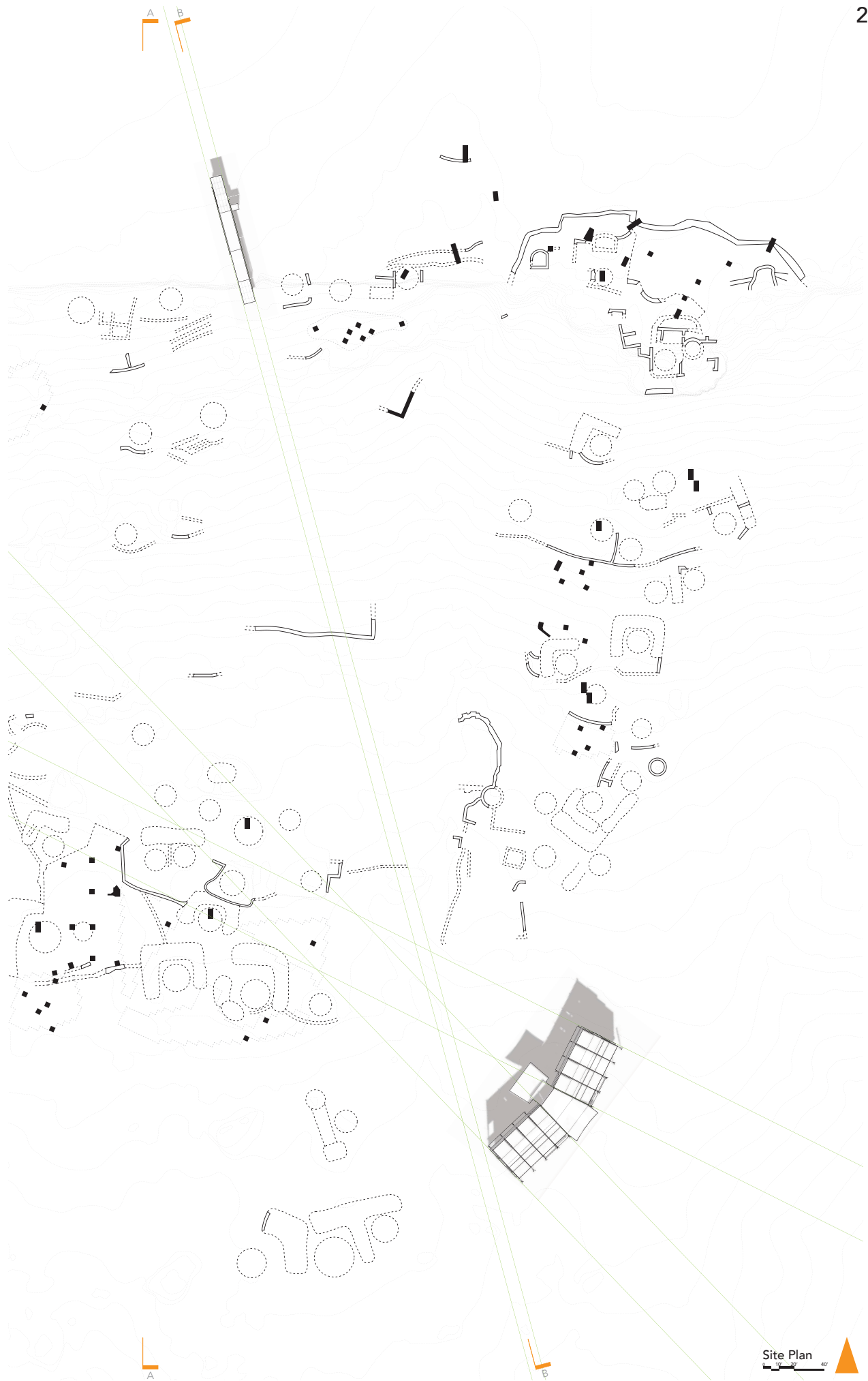



Site Section B-B

Site Section A-A

Site Model

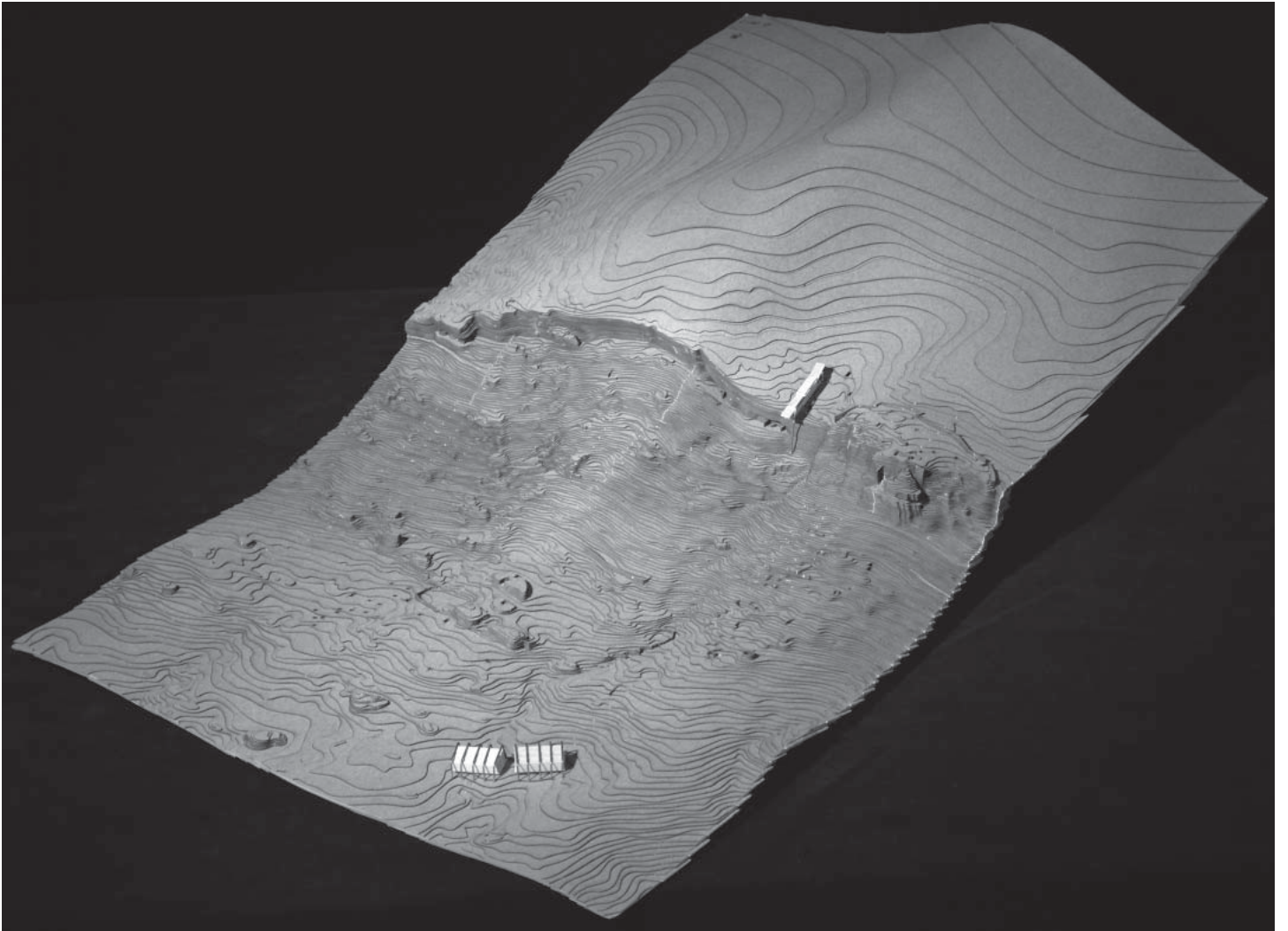
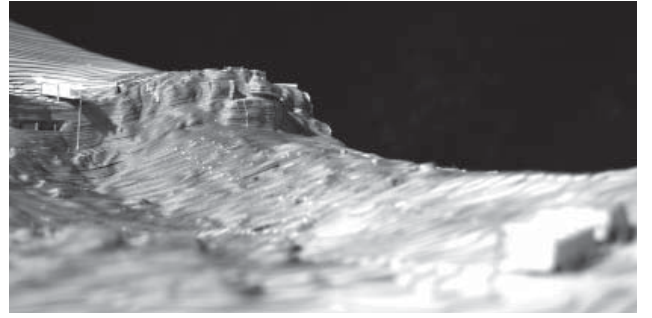
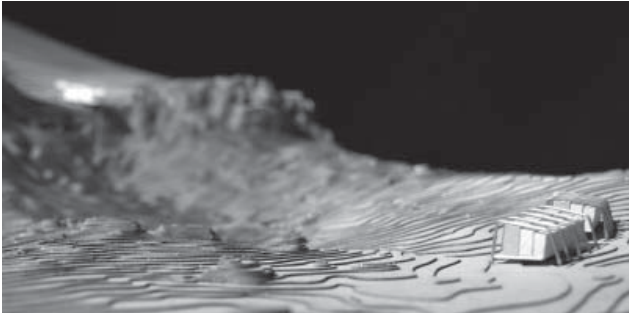
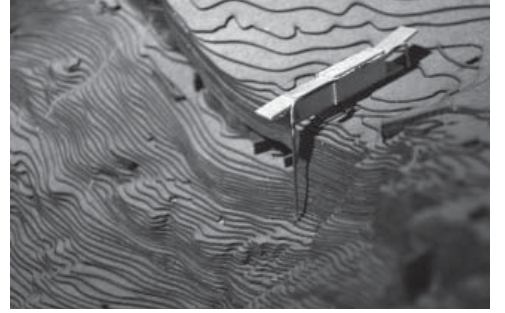

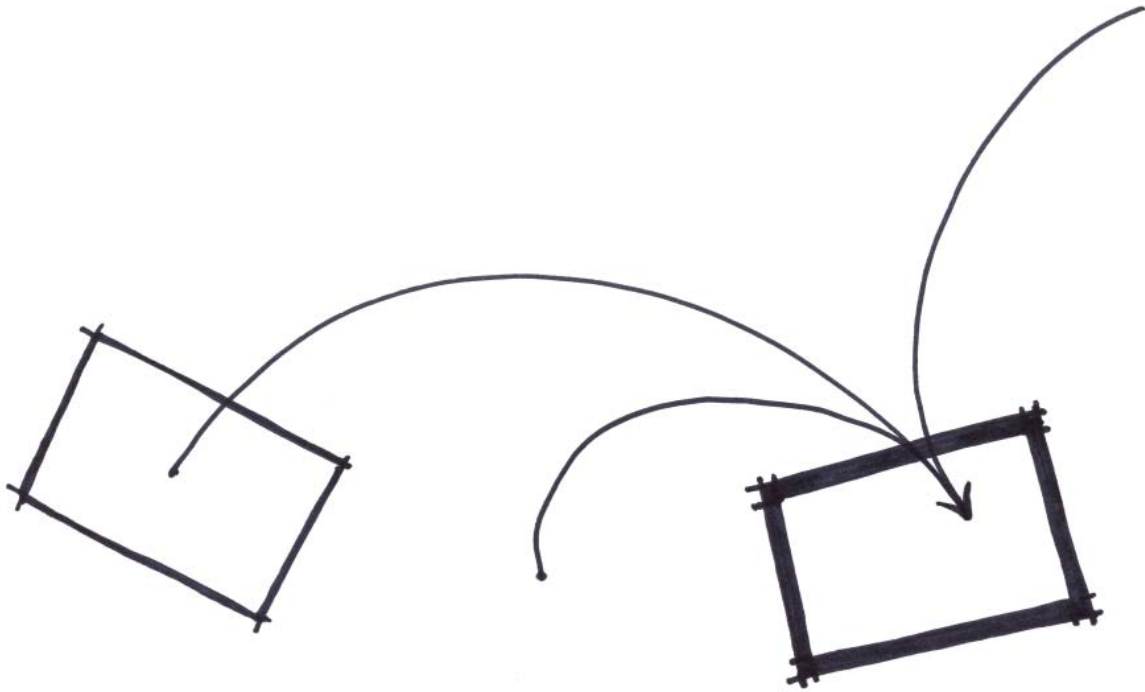

Design Project: Mobile Archaeology Labs

I began the design process of the archaeology labs by exploring the various strategies that might be used to make a building mobile. A series of study models was created to test the tectonics and forms that these strategies might take. Initially, the program elements were spread across the site, each in their specific structure. This provided a high-level of flexibility as the site and crew changed size, but made the functioning and deployment awkward and somewhat too chaotic. The program elements were then overlapped and layered either vertically or horizontally through various means, resulting in the final design of a single multifunctional space with adaptable furnishing and a sleeping loft above. The first several iterations of the project consisted of differing scales of tensile, tent-like structures. This idea was later replaced by the nested, telescoping form of the final design. The tensile elements remained as the more temporary and flexible outdoor areas and sun protection. The lifting action - which creates the angled walls of the fully extended building - occurs in order to make room above for the sleeping loft and also solves rainwater drainage issues by forming a sloped roof. An animation was created to test the unfolding action of the building, which shows the arrival and deployment process and how the building lifts itself off of the trailer on which it arrives. The building is modular, and the first one to arrive would have a cooking and eating space which the subsequent modules would lack, making it the anchor and daily gathering place of its archaeological community.

Strategies for Achieving Mobility in Buildings



Telescoping

Tensile

Rolling

Pneumatic

Earthbags

Exploration of Separate Tent-like Structures

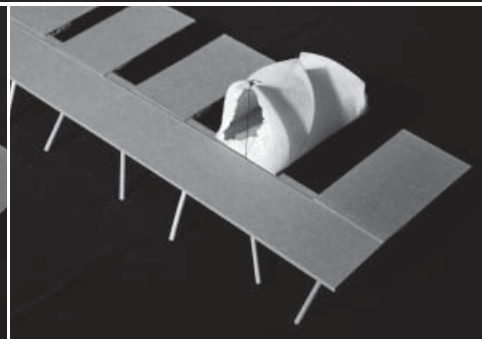
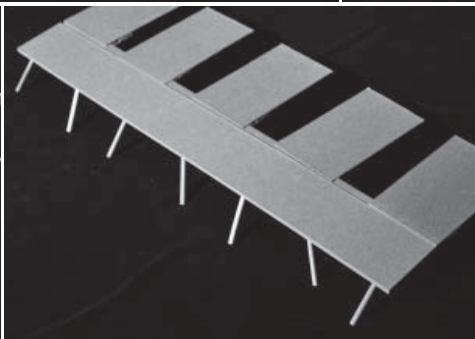
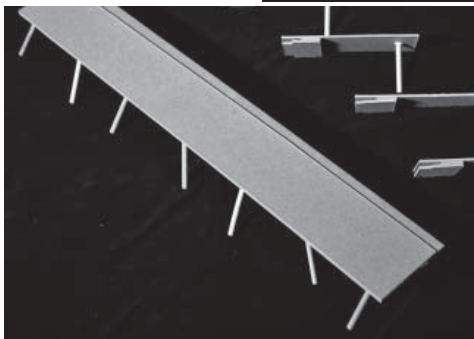
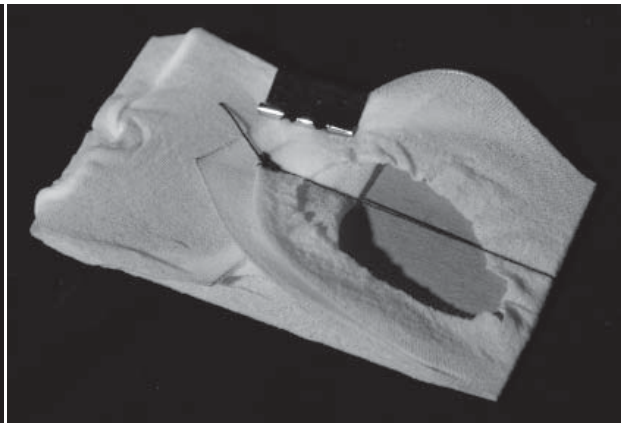
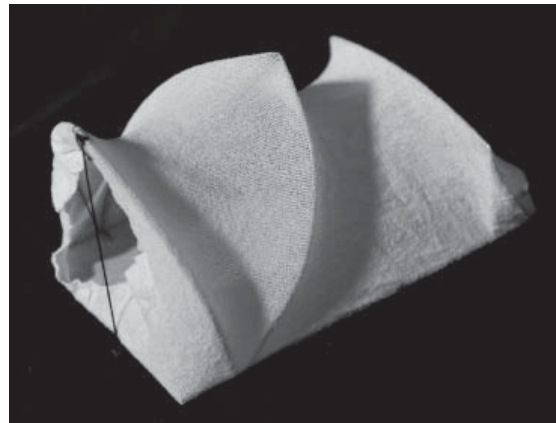
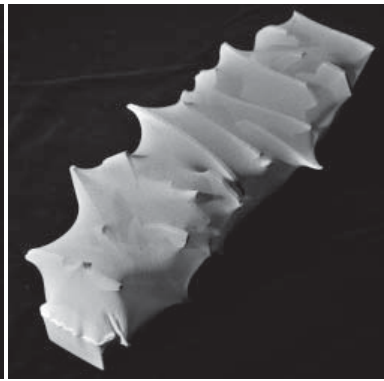
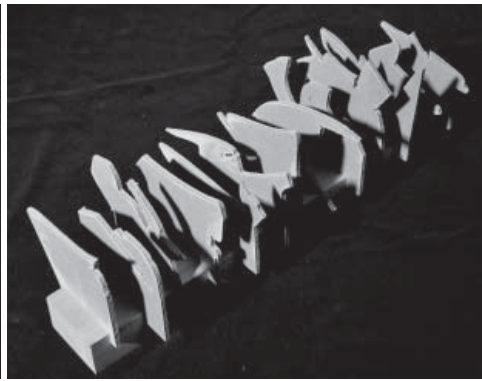
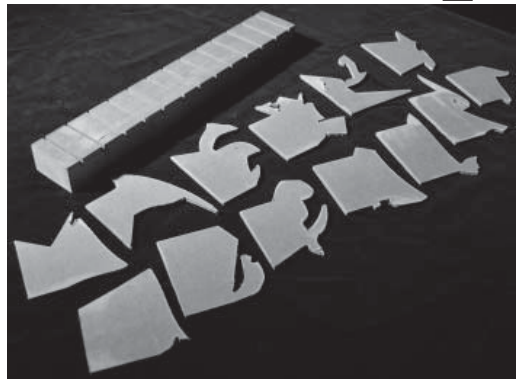
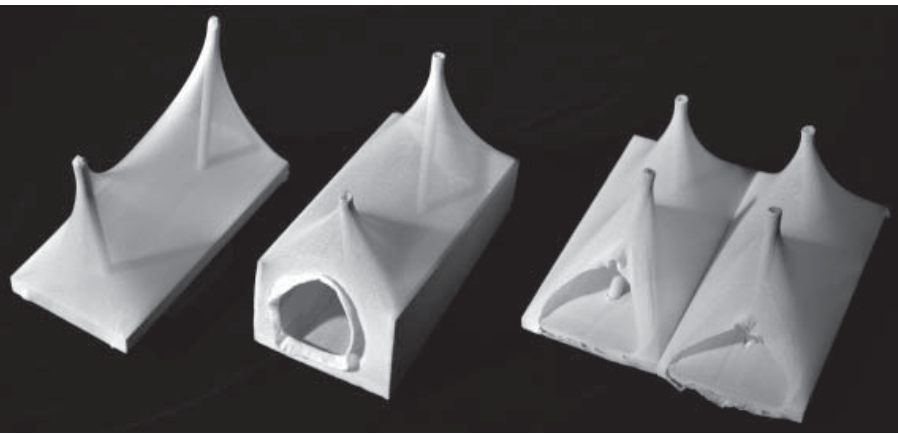
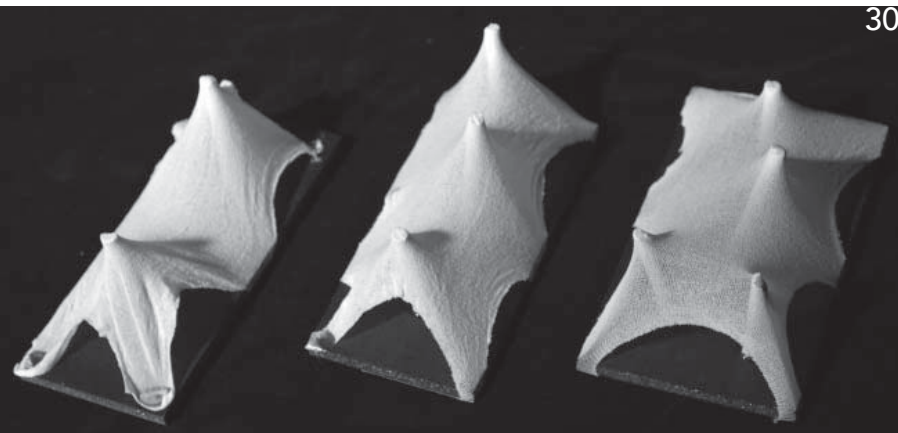

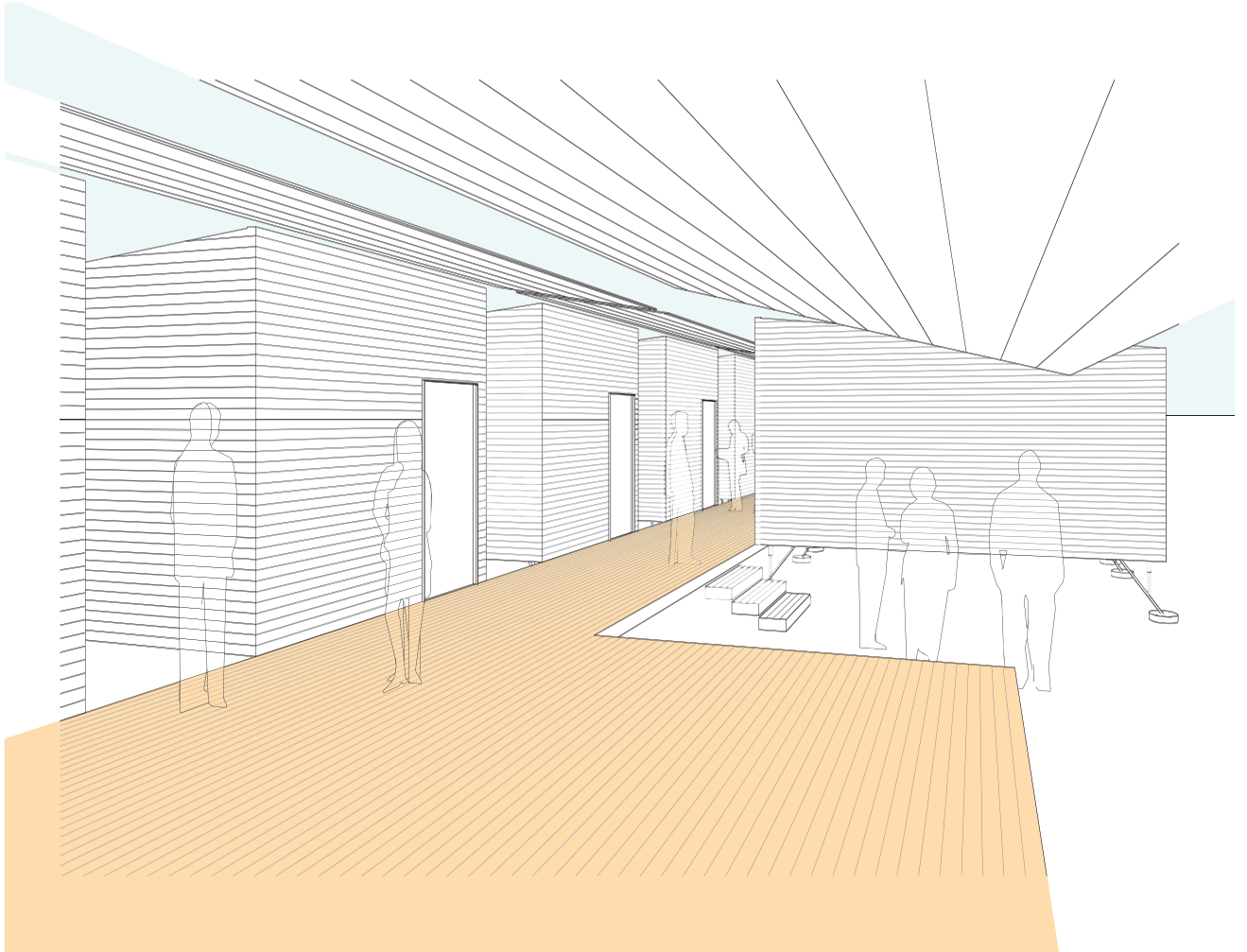
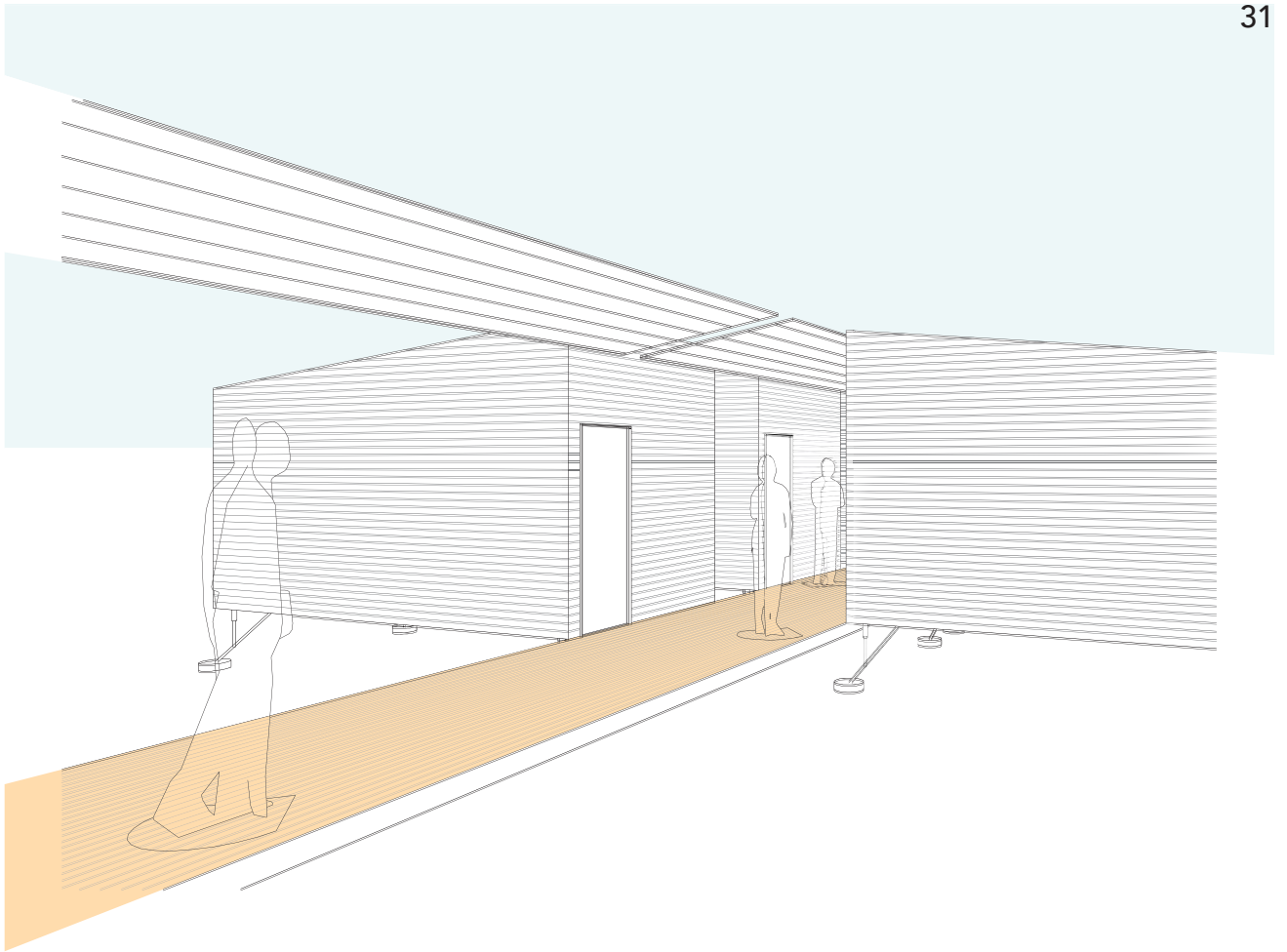

Explorations of a Multi-Functional, Modular Unit

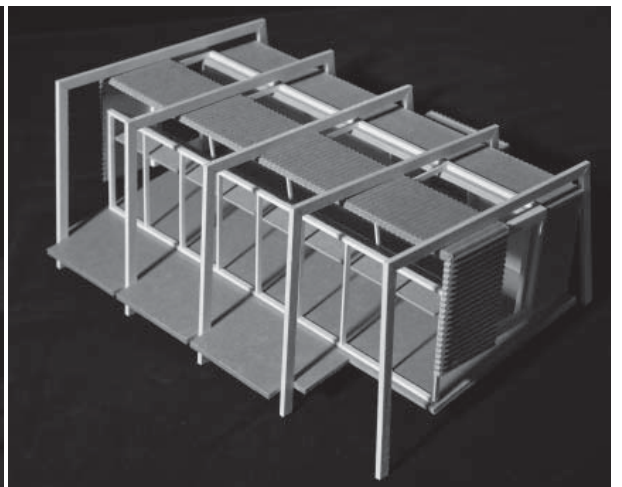
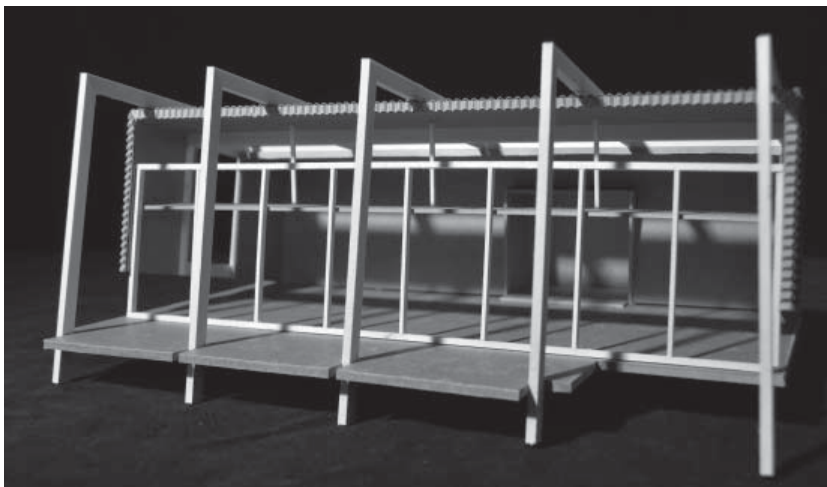
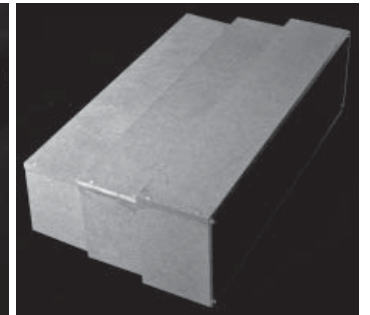
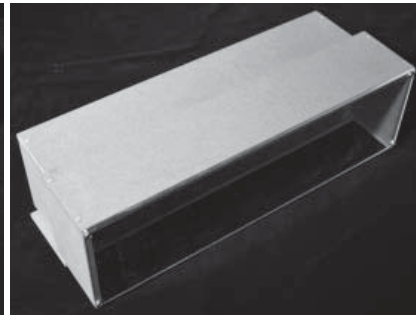
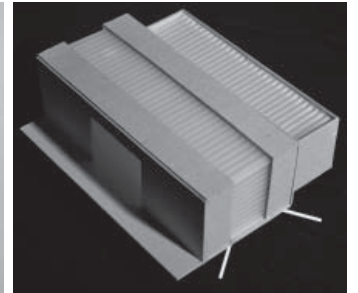
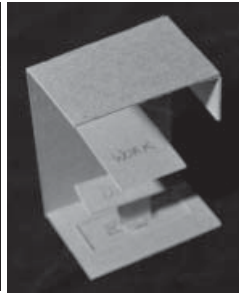
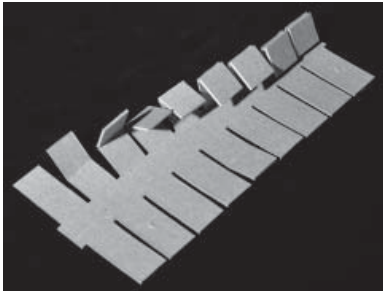
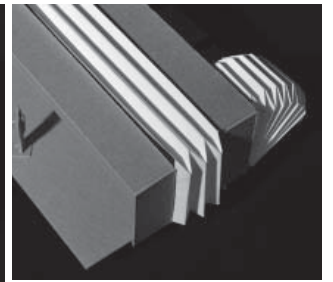
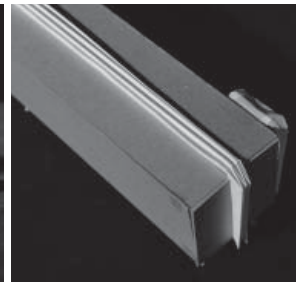
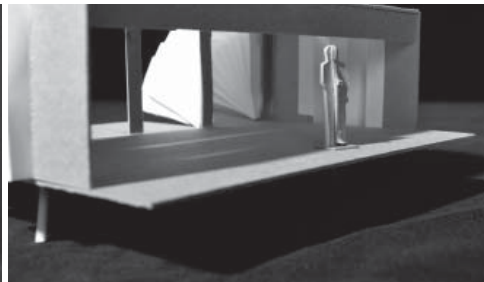
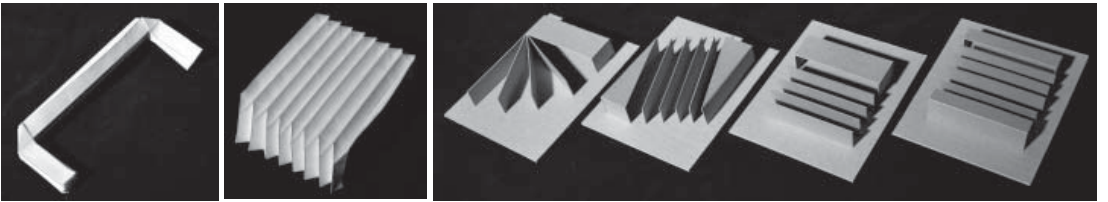
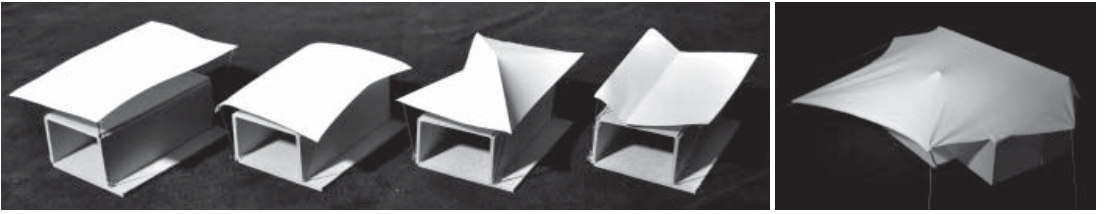

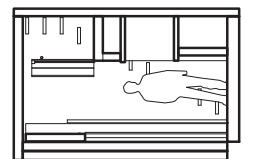
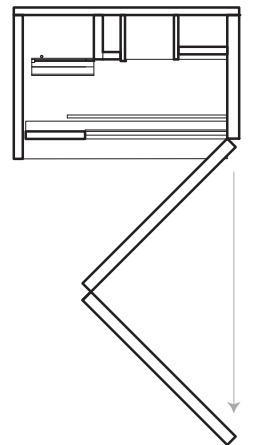
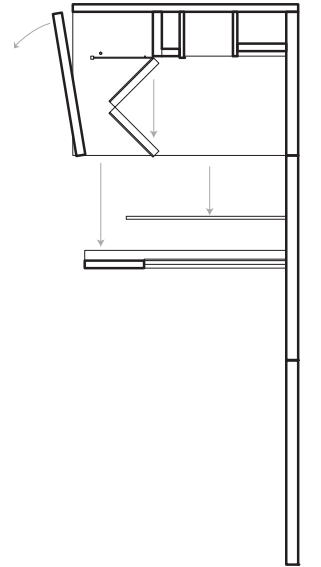
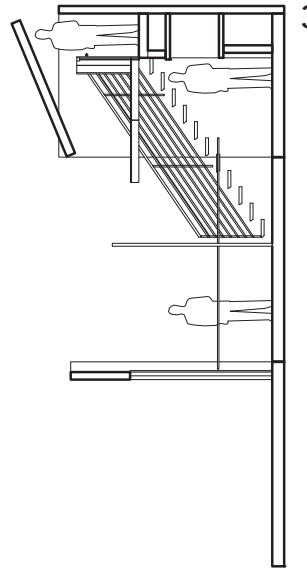
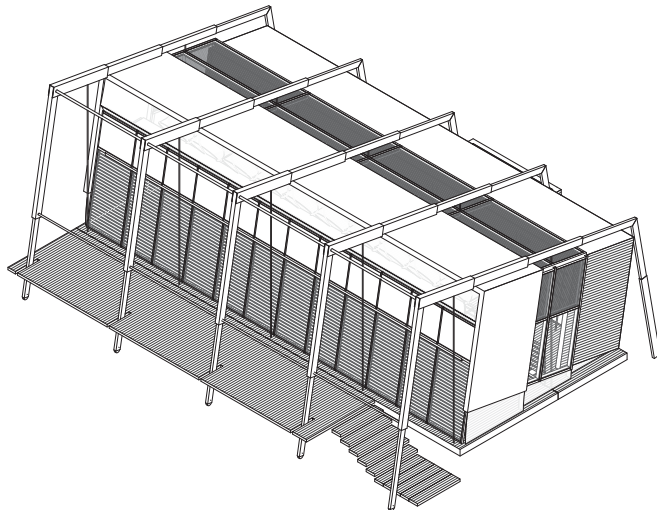
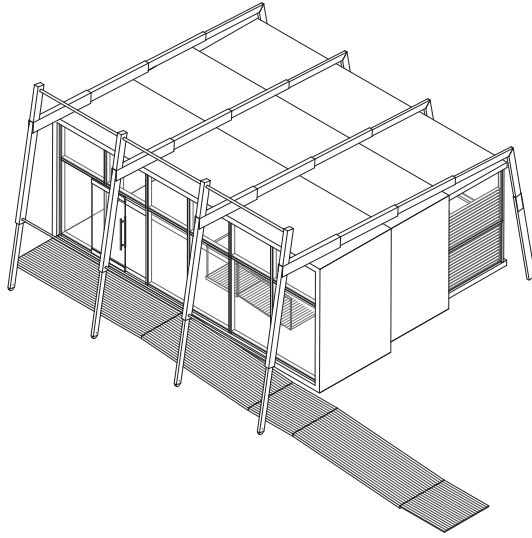
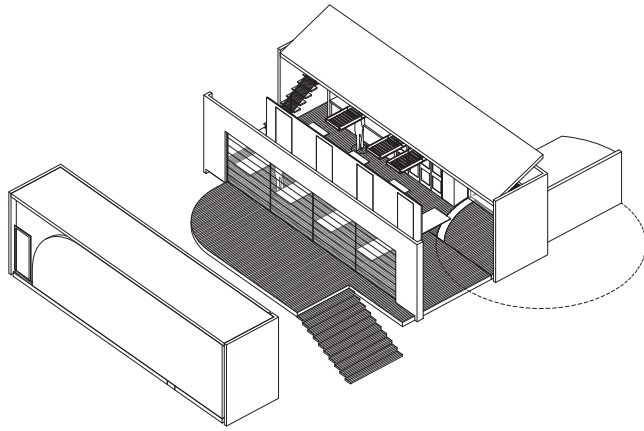
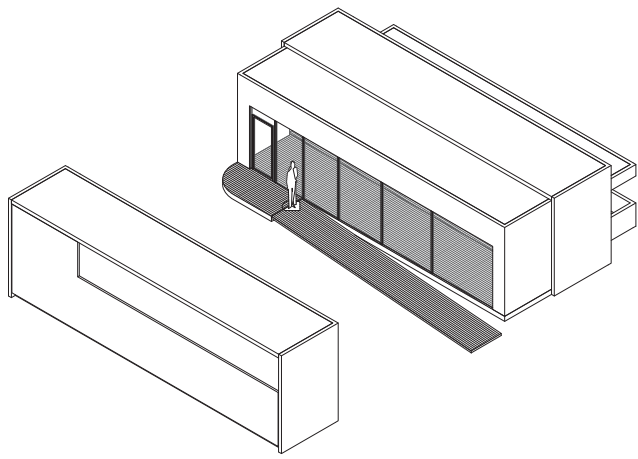

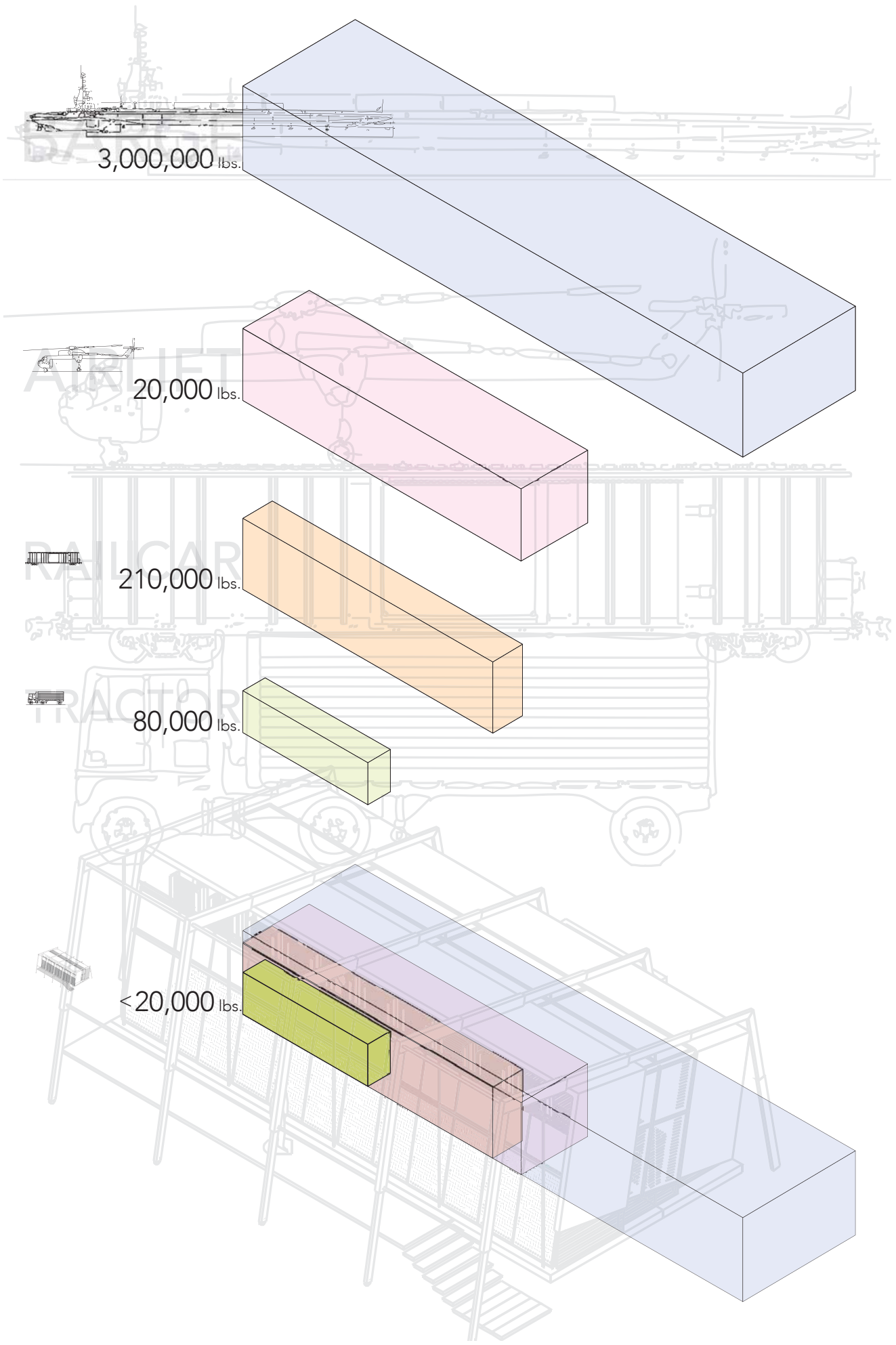

ORIGINAL FORM

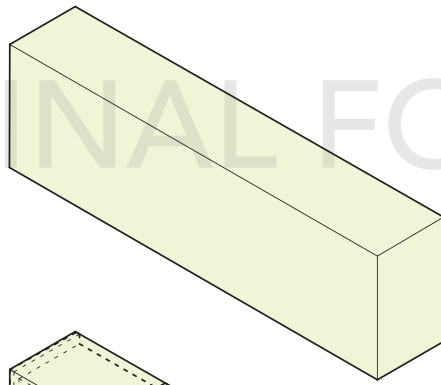

DIVIDE

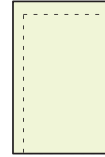
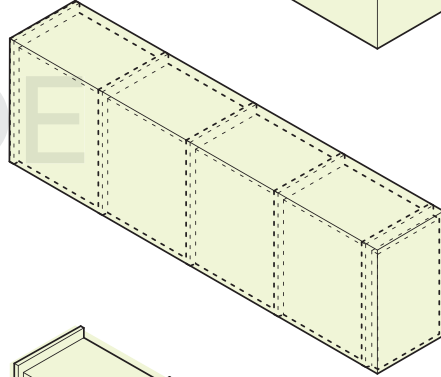

SUBTRACT

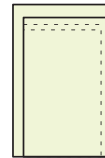
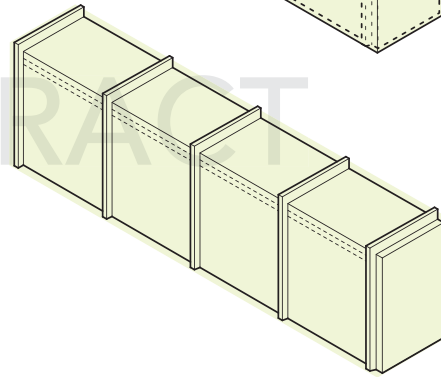

EXTEND

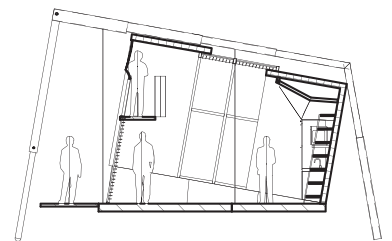
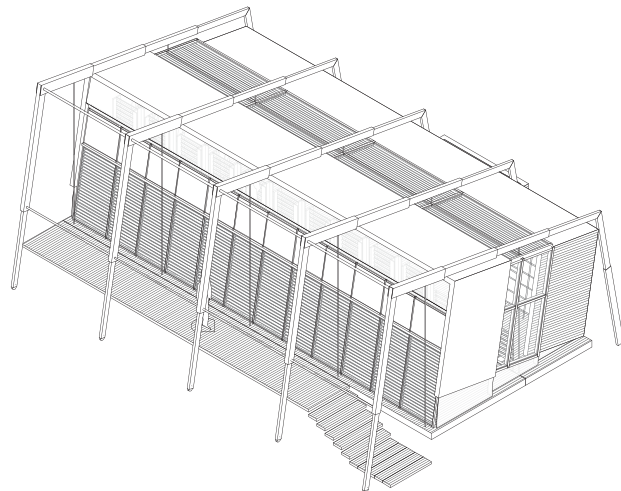
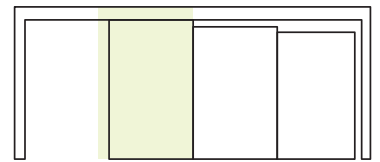
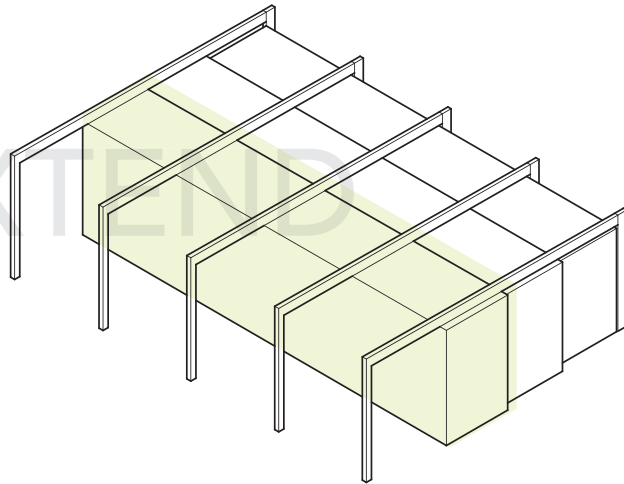



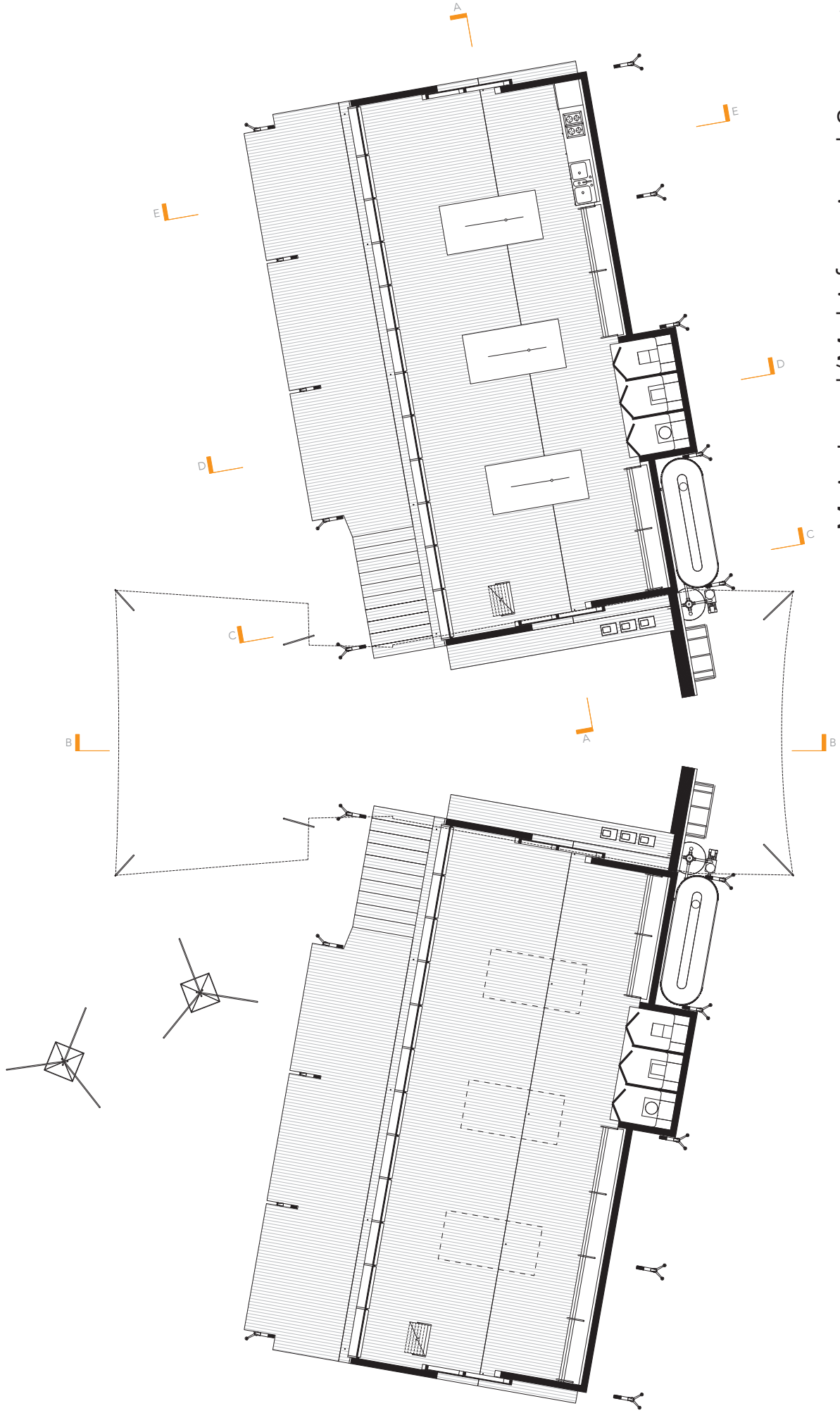

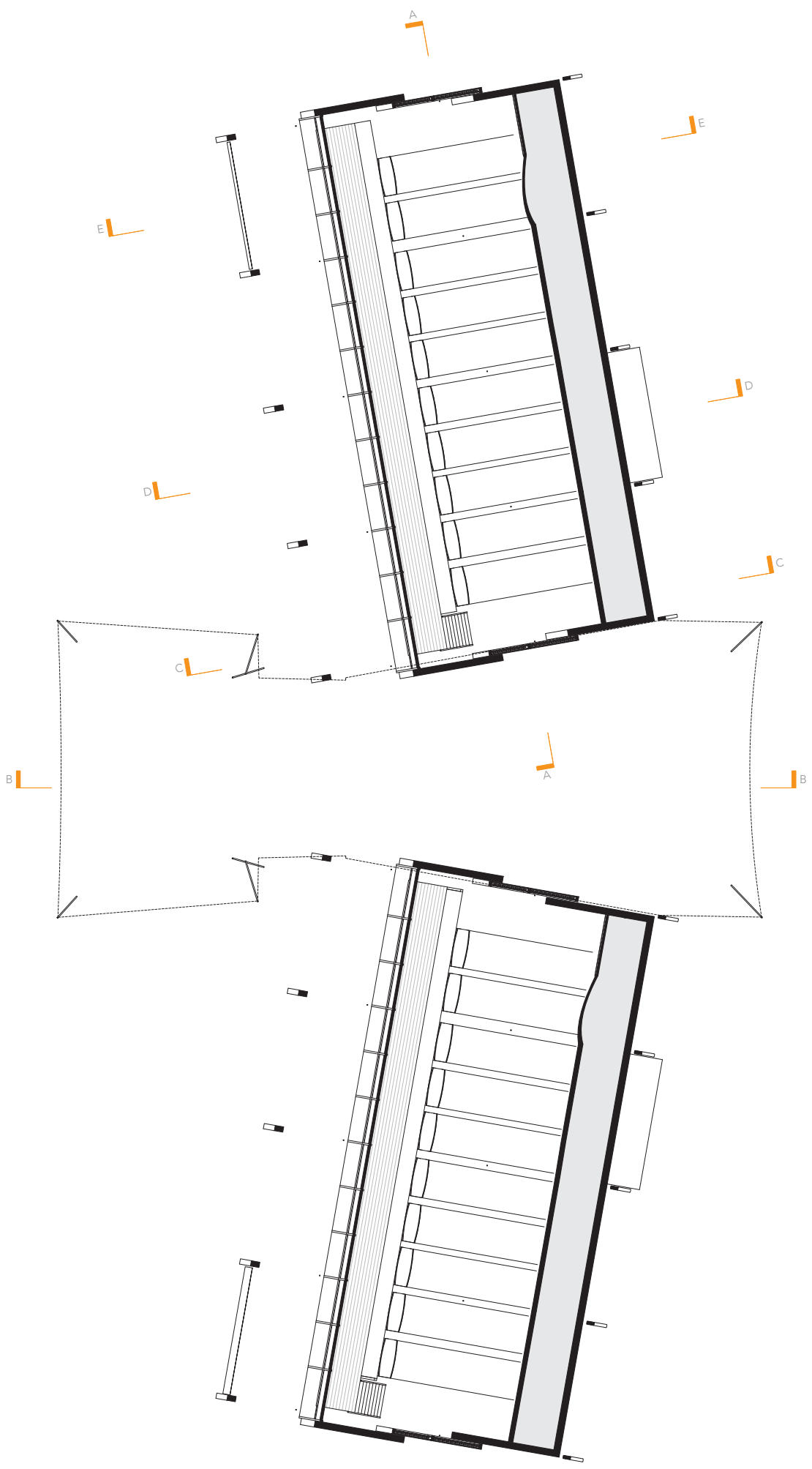

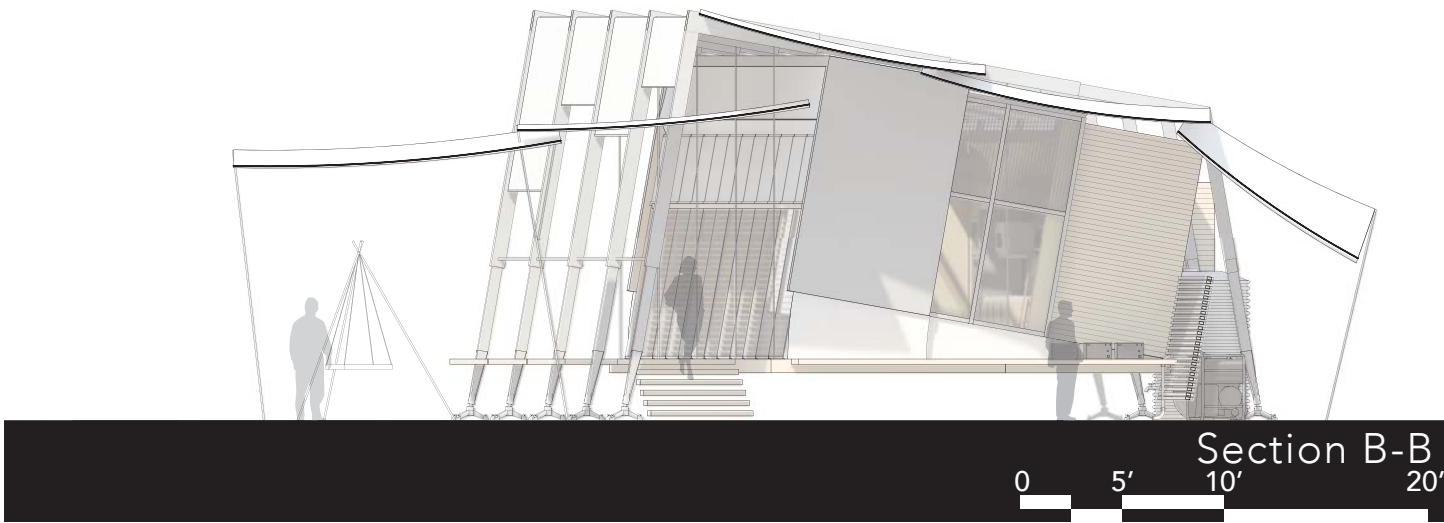
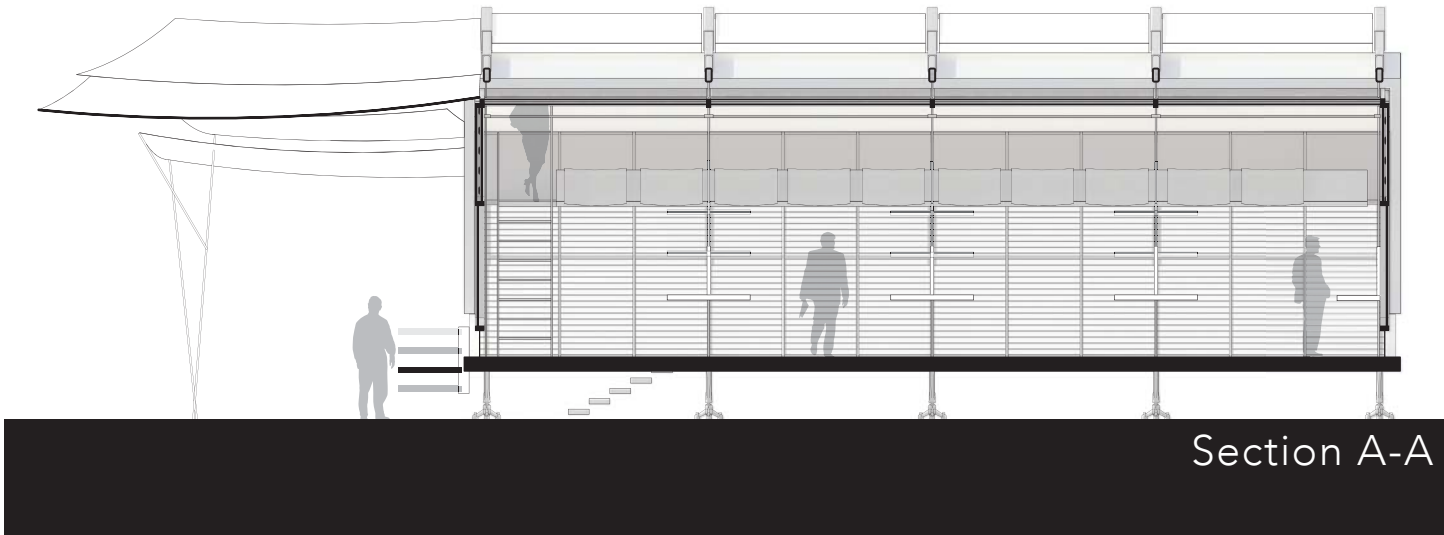

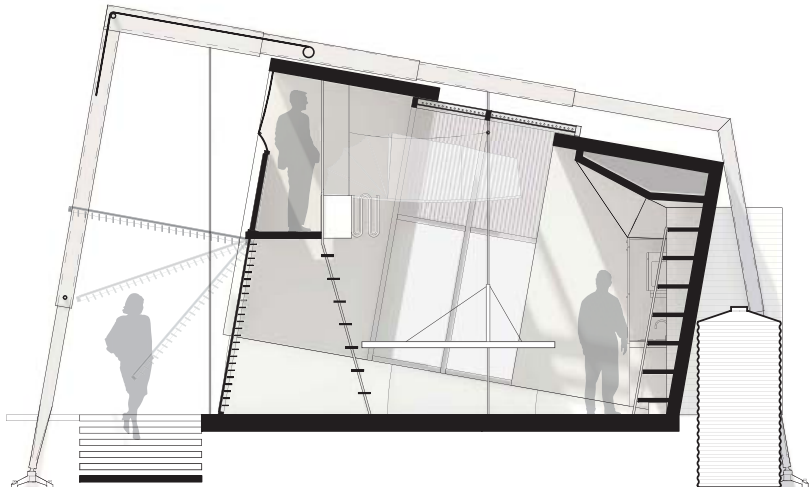

Section C-C

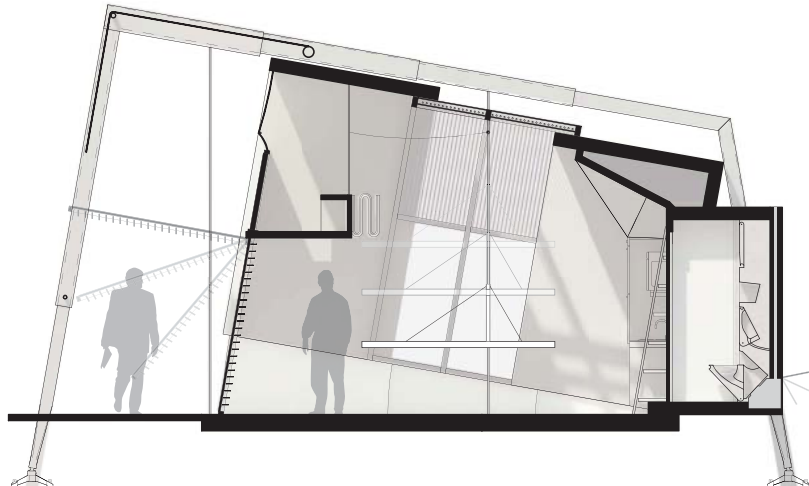

Section D-D

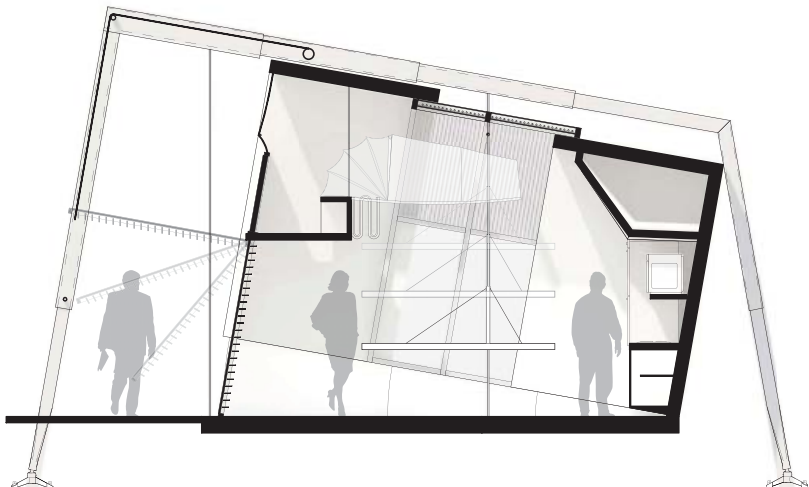

Section E-E



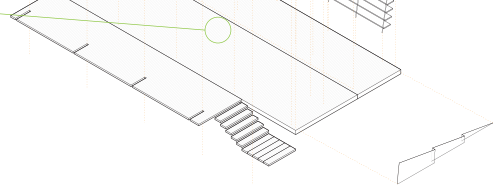
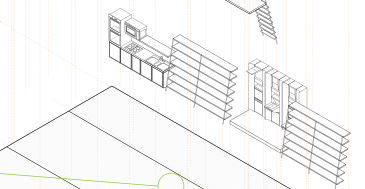
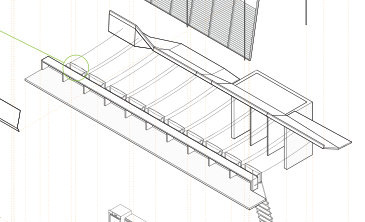
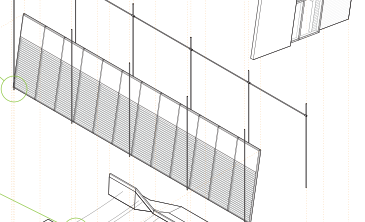
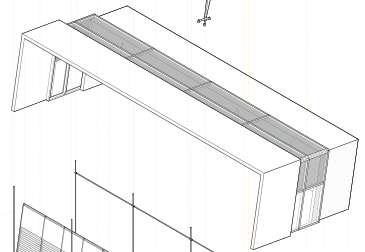
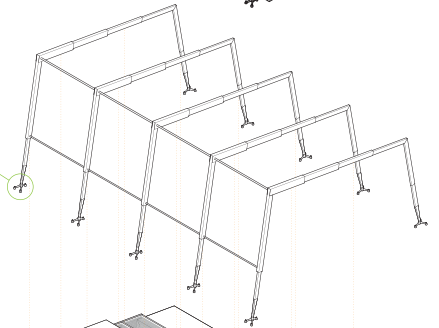
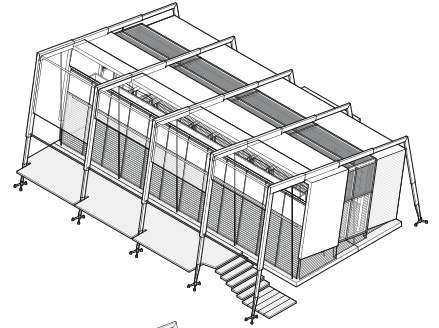
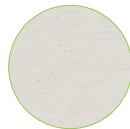
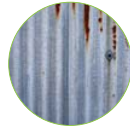
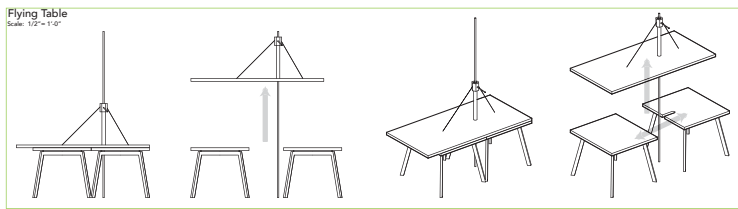
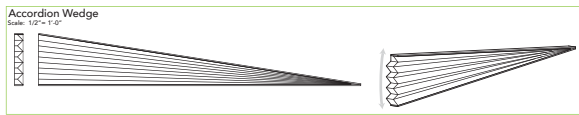
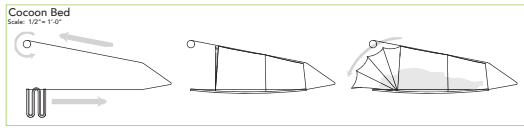
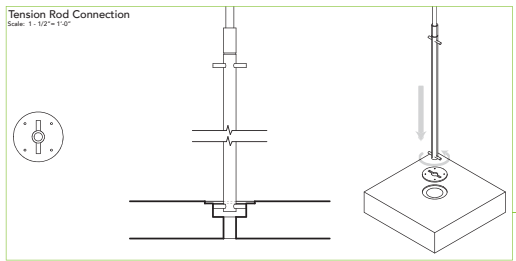
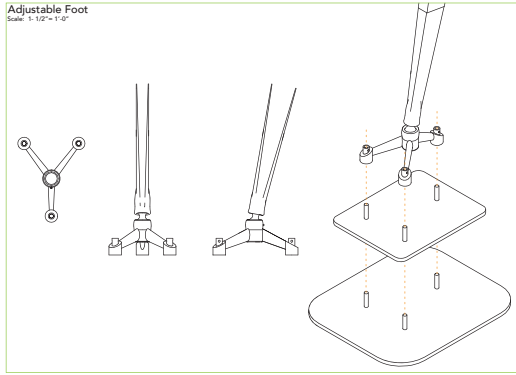

Exploded Axonometric and Details

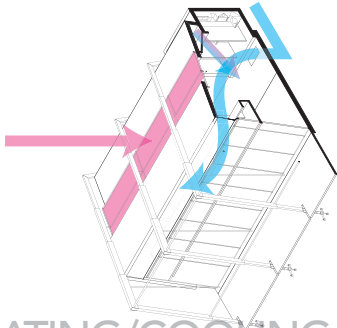

HEATING/COOLING

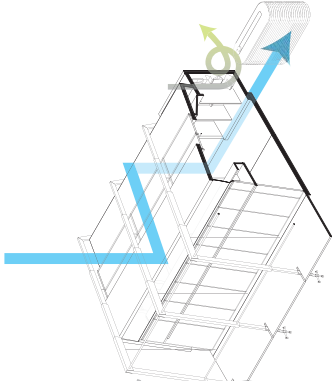

WATER/WASTE

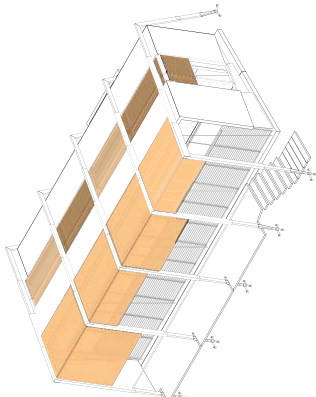

SOLAR SHADING/COLLECTION

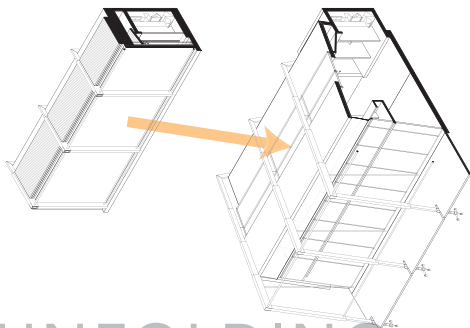

UNFOLDING

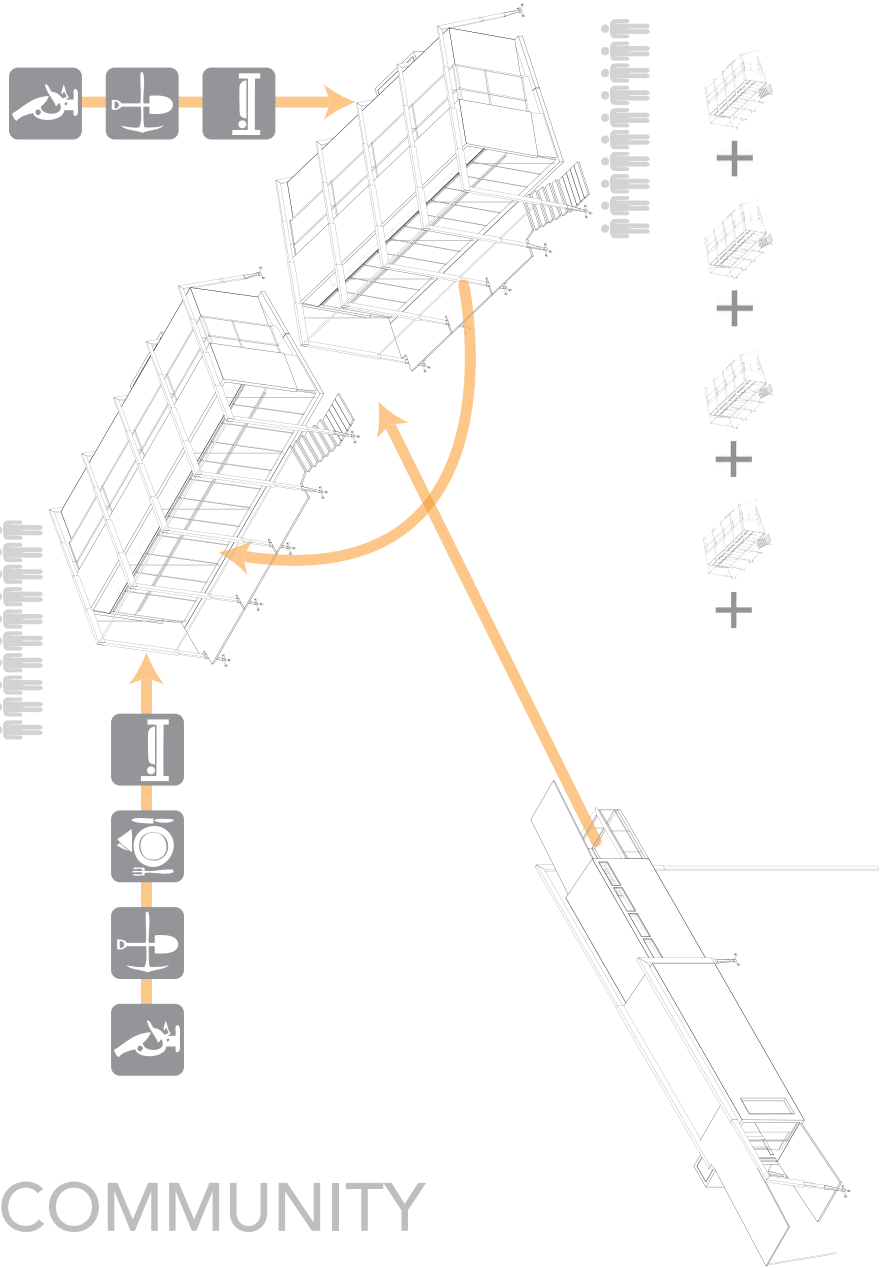

COMMUNITY

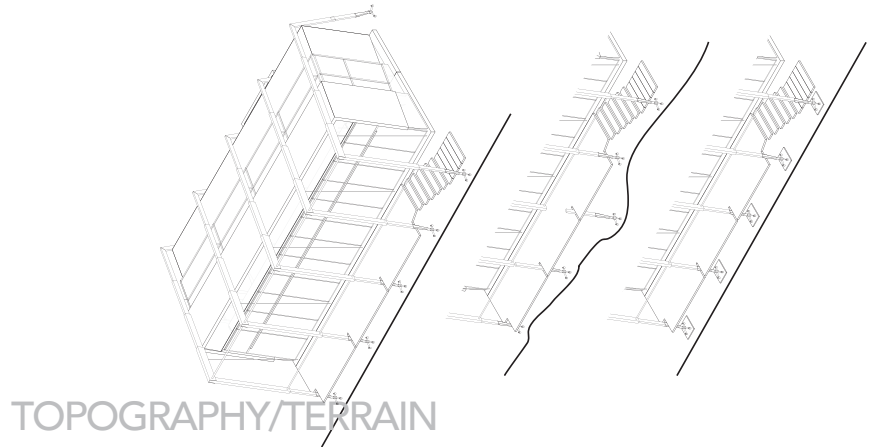

TOPOGRAPHY/TERRAIN





Interior Perspectives

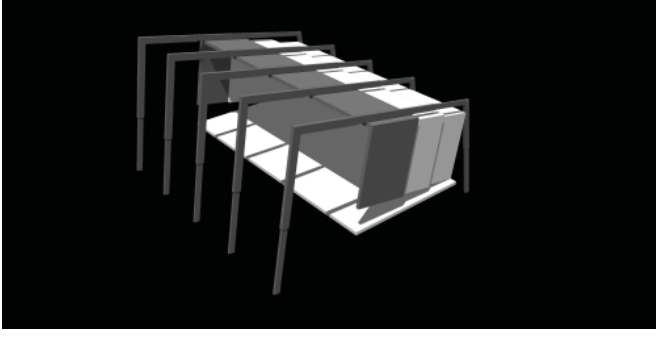
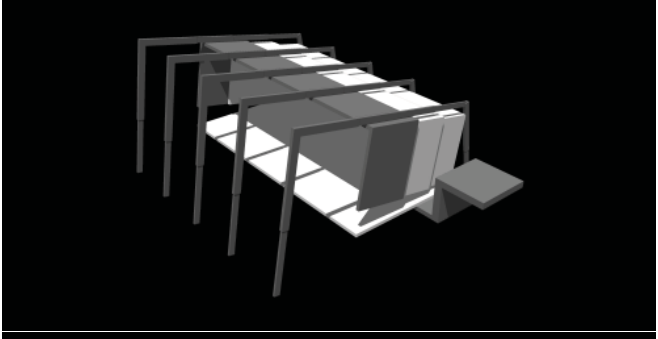
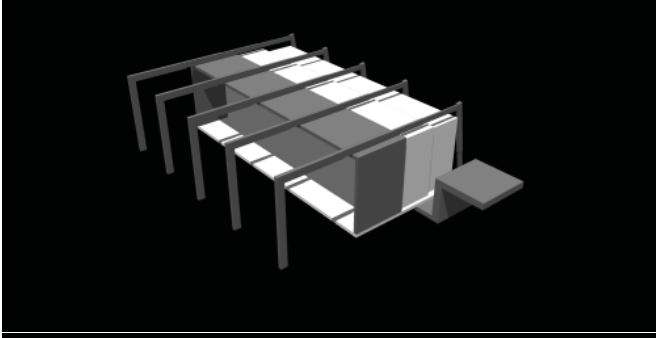
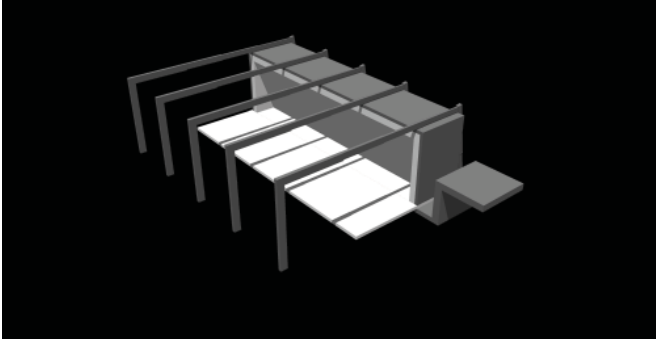
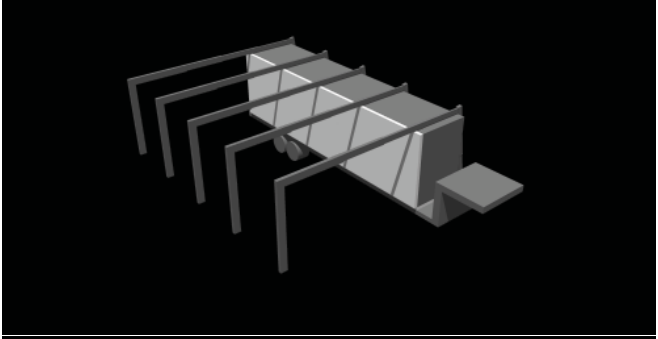
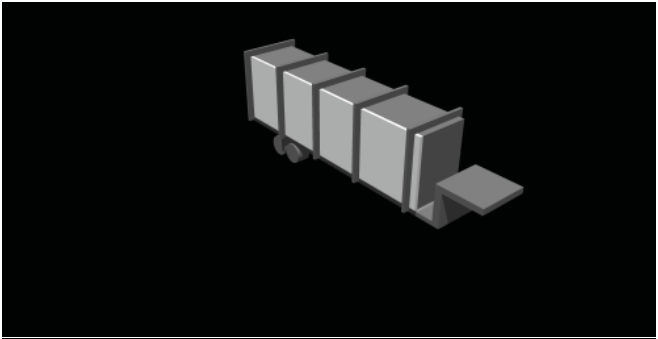

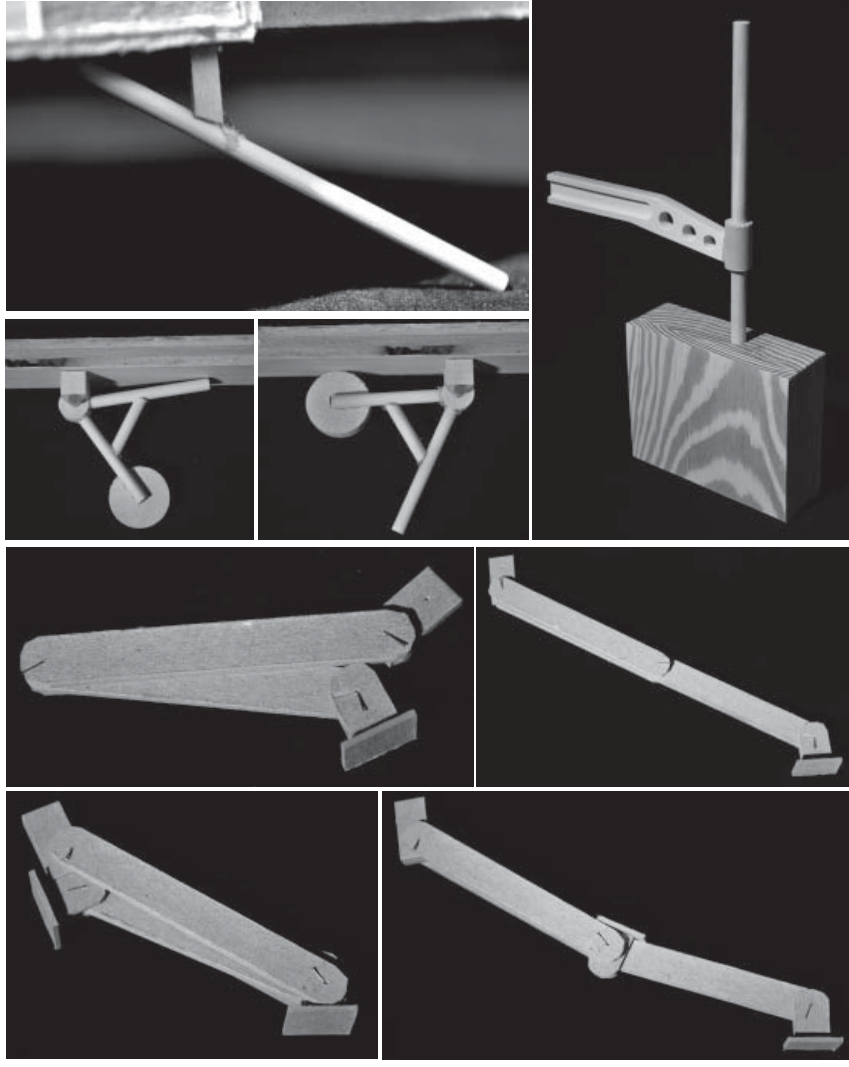
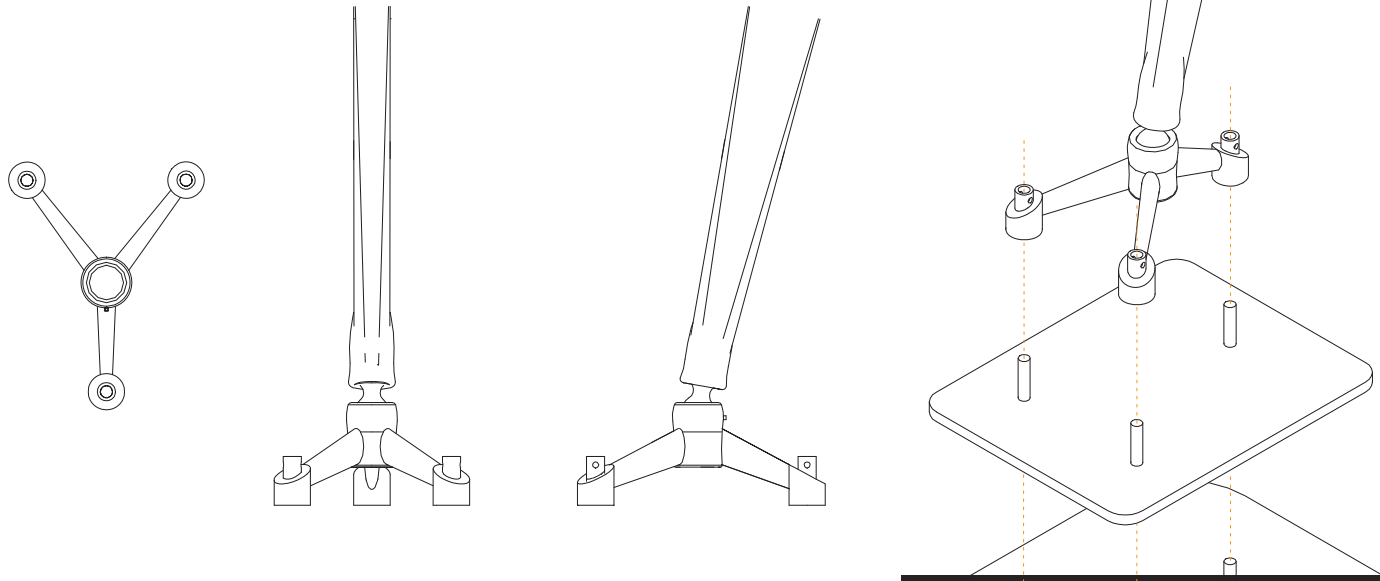

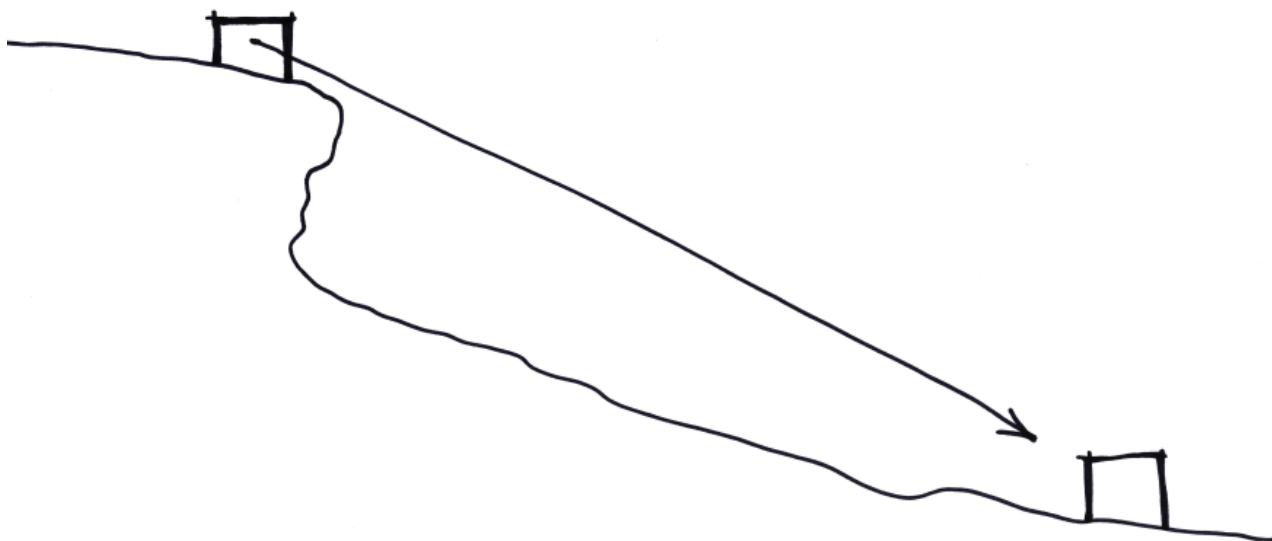

Design Project: Travelling Community Museum

The mobile community museum uses the same telescoping and lifting actions as the multifunctional buildings, though it unfolds in the opposite direction. The building is open at both short faces, forming a two-way visual tunnel connecting the outside community with the itinerant archaeological community. The building is suspended over the cliff face by a long slender leg which is added as an extension of the integral leg. The building acts as a simple path or timeline, showing an overview of the archaeological process in a large info-graphic, then displaying the current dig operations and photographs of artifacts on digital displays, then displaying actual artifacts from the dig site, and ending on an observation deck from which visitors can watch the activity on the site.

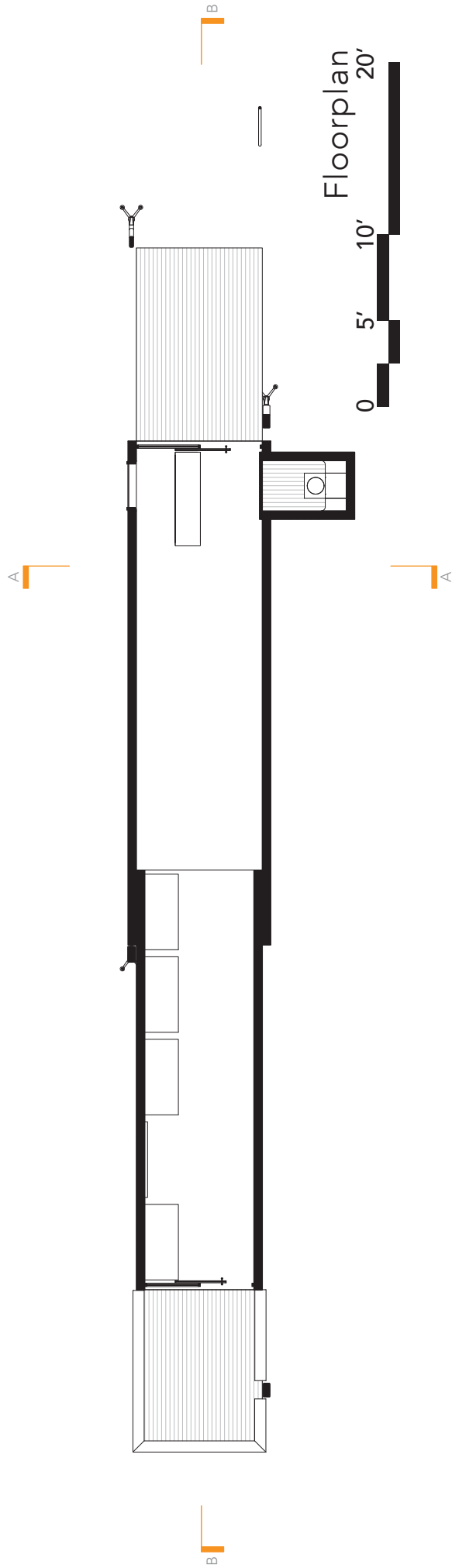



Section A-A

0

5'

10'

20'

Section B-B

49

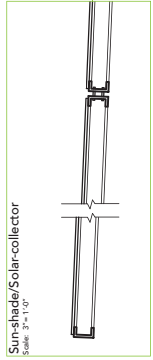

Sun-shade/Solar-collector
Scale: 1" = 1'-0"

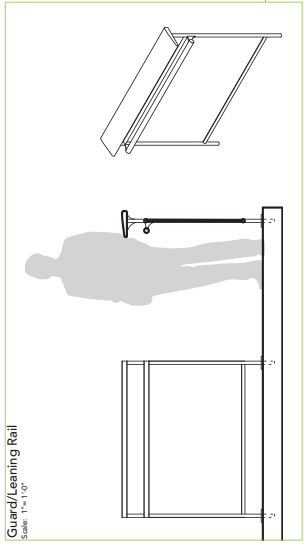

Guard/Leaning Rail
Scale: 1" = 1'-0"

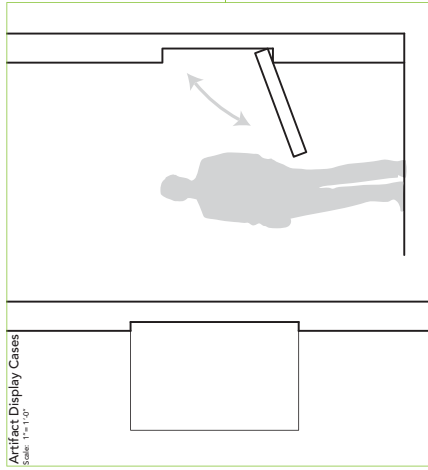

Artifact Display Cases
Scale: 1" = 1'-0"

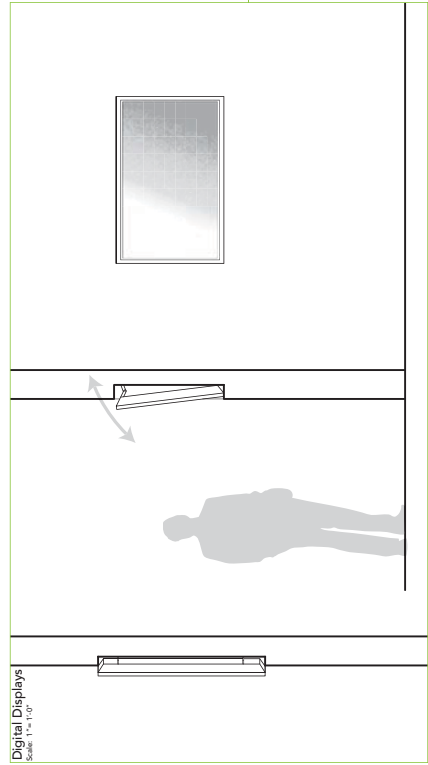

Digital Displays
Scale: 1" = 1'-0"

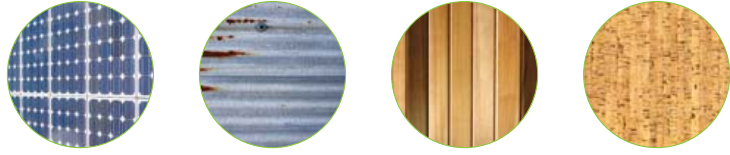
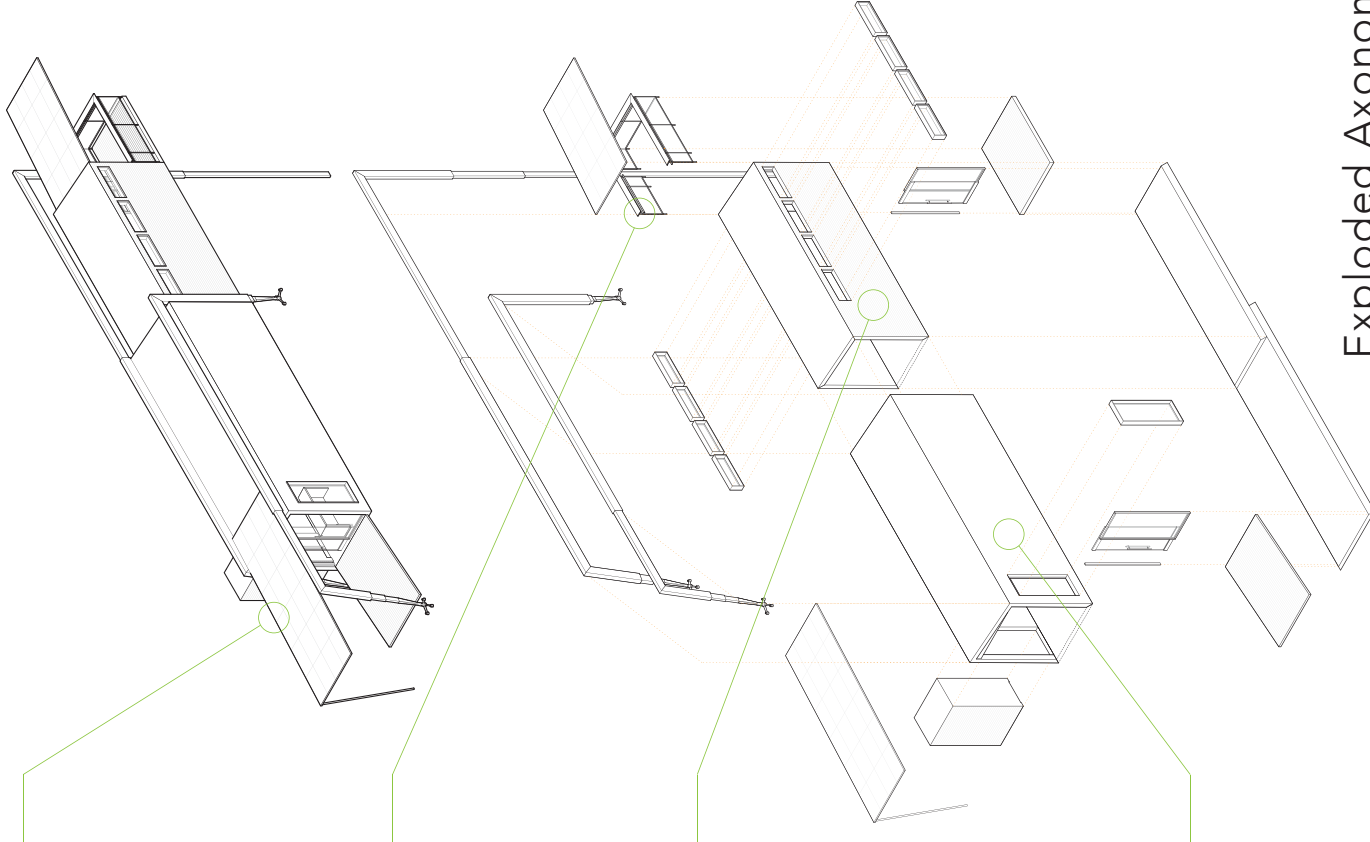



SITE

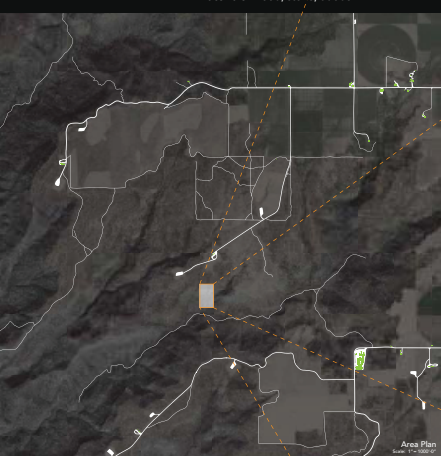
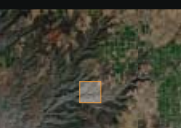
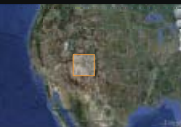
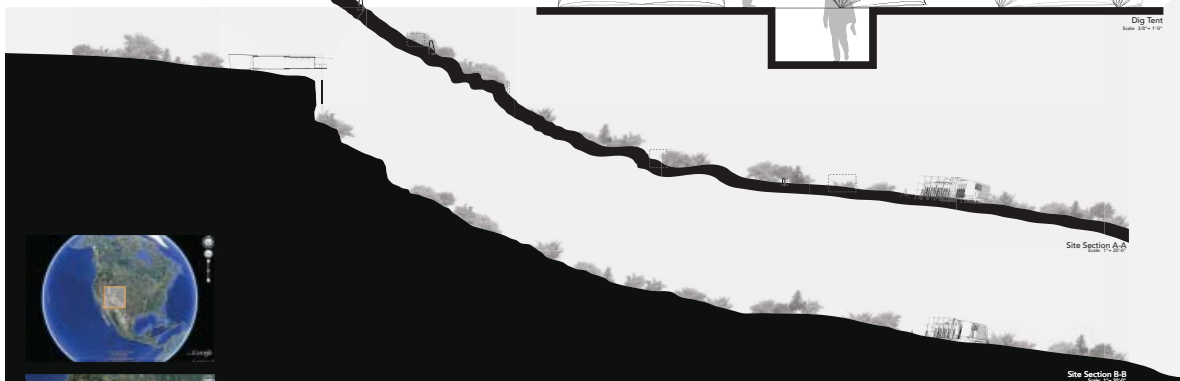
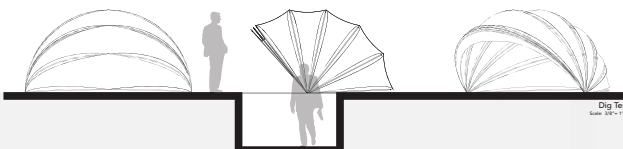
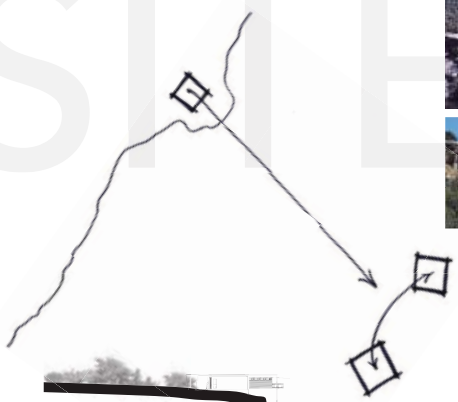

Cortez, CO – "Woods Canyon Pueblo"
 Site ID#: 5MT11842
 Site Size: 7.8 acres/3.2 hectares
 Excavated by Crow Canyon Archaeological Center between 1994 and 1996
 Area of site excavated: 0.3%
 Age of ruins: A.D. 1150 – A.D. 1300 (Pueblo III Period)
 Original civilization: Pueblo (Anasazi)
 Civilization type: Agricultural/Hunter-Gatherer
 Agriculture: corn, beans, squash; domesticated turkeys and dogs
 Ruins: 200+ structures; 50 kivas (circular religious/community buildings), 16 towers, 150+ rooms, several water-control features (check-dams, reservoirs, etc.)
 Original Population: 50-200
 Materials: wood, stone, adobe

Climate Data

	J	F	M	A	M	J	J	A	S	O	N	D
High	41°	46°	53°	63°	73°	83°	89°	86°	79°	67°	52°	43°
Low	13°	19°	25°	31°	39°	46°	54°	53°	45°	34°	23°	15°
Precipitation	1016	788	655	395	162	23	1	45	297	679	961	
Days				1	29	166	356	300	99	4		
Hours	10	11	12	14	15	15	15	14	13	11	10	10
Minutes	2											1
Monthly Temperature	102° / -30°											
Annual Temperature	30 180											
Annual Precipitation	12.9" 12.6"											

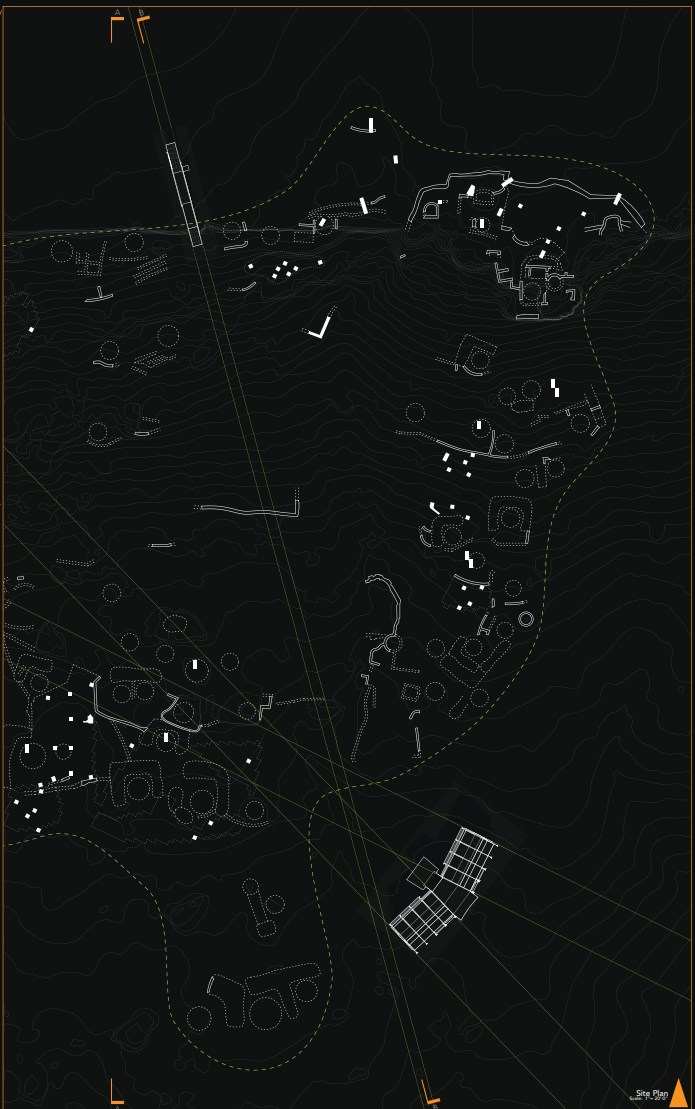

MOBILE LABS

PLACEMAKING & COMMUNITY IN MOBILE ARCHITECTURE

an itinerant archaeological community
for remote site exploration

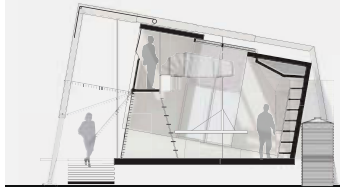
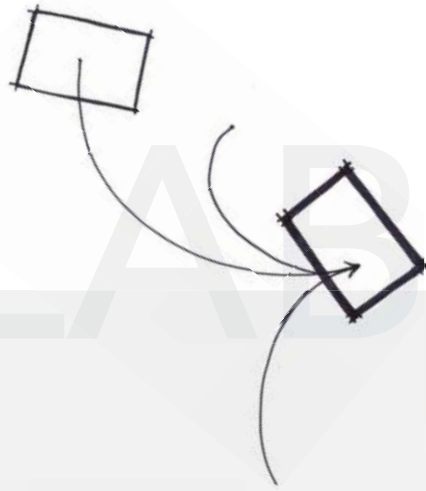

Section E-E
Scale: 1/8" = 1'-0"

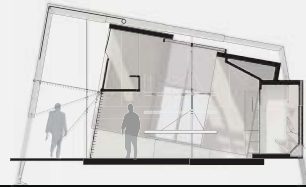

Section D-D
Scale: 1/8" = 1'-0"

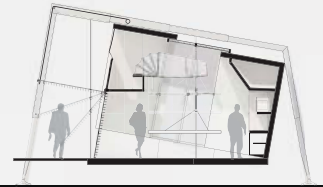

Section C-C
Scale: 1/8" = 1'-0"

Adjustable Foot

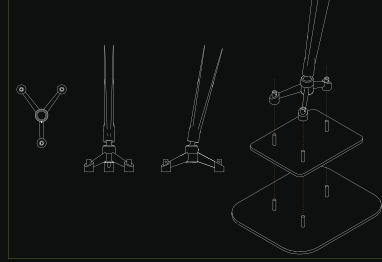

Tension Rod Connection

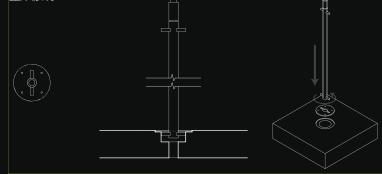

Cocoon Bed



Accordion Wedge



Flying Table

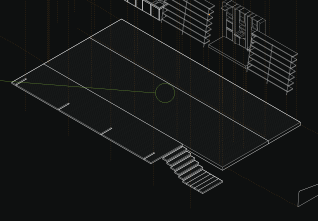
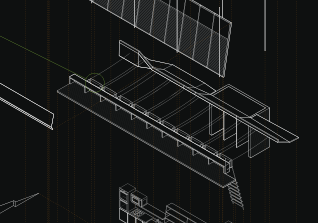
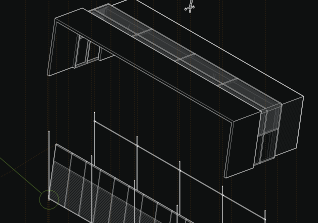
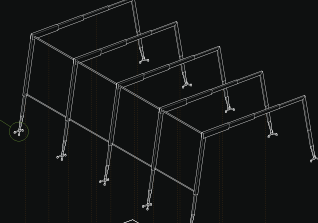
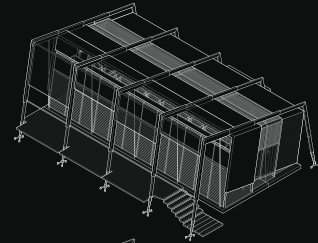
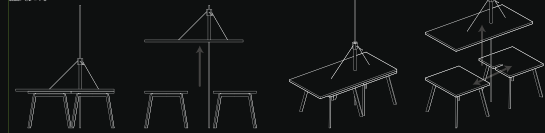

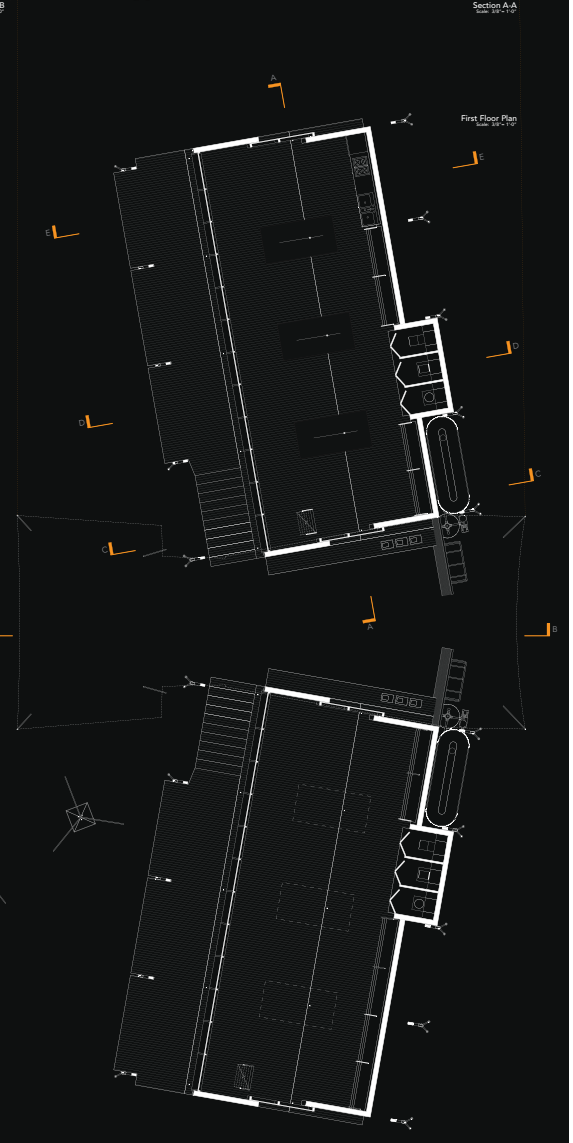
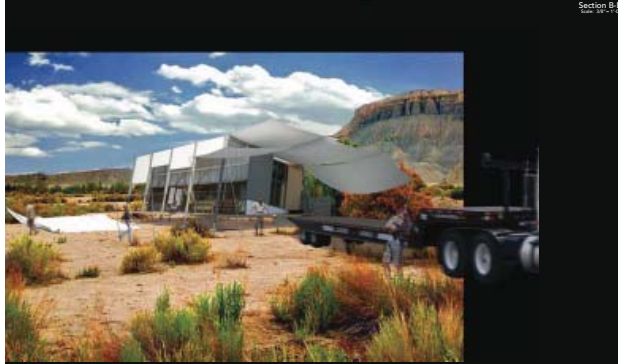
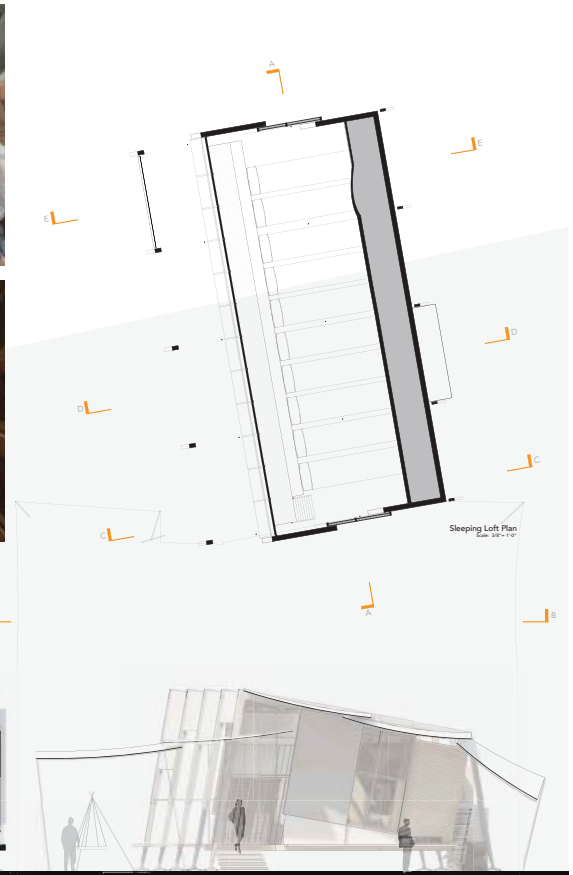
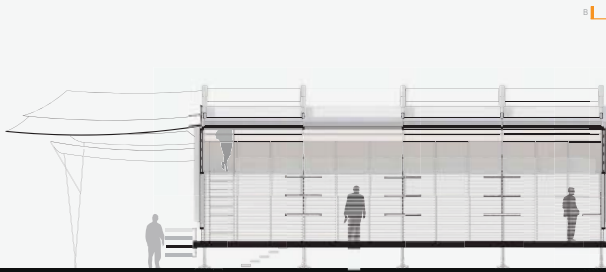

MUSEUM

