

6-26-2011

Guided Discovery Modules for Statics and Dynamics

Javier A. Kypuros

University of Texas at Tyler, JKypuros@uttyler.edu

Horacio Vazquez

Constantine Tarawneh

Robert R. Wrinkle

Follow this and additional works at: https://scholarworks.uttyler.edu/me_fac



Part of the [Mechanical Engineering Commons](#)

Recommended Citation

Kypuros, Javier A.; Vazquez, Horacio; Tarawneh, Constantine; and Wrinkle, Robert R., "Guided Discovery Modules for Statics and Dynamics" (2011). *Mechanical Engineering Faculty Publications and Presentations*. Paper 10.

<http://hdl.handle.net/10950/642>

This Article is brought to you for free and open access by the Mechanical Engineering at Scholar Works at UT Tyler. It has been accepted for inclusion in Mechanical Engineering Faculty Publications and Presentations by an authorized administrator of Scholar Works at UT Tyler. For more information, please contact tbianchi@uttyler.edu.

AC 2011-1171: GUIDED DISCOVERY MODULES FOR STATICS AND DYNAMICS

Dr. Javier A. Kypuros, The University of Texas-Pan American

DR. JAVIER A. KYPUROS is an Associate Professor of Mechanical Engineering at the University of Texas-Pan American. He received his B.S.E from Princeton University in 1996, and his M.S.E. and Ph.D. from the University of Texas at Austin in 1998 and 2001, respectively. He is actively involved in researching methods to implement and assess multimodal, challenge-based modules for Mechanical Engineering curriculum including Engineering Mechanics, System Dynamics, and Automatic controls. Dr. Kypuros has developed numerous web-based and video-facilitated modules to better illustrate fundamental concepts or elucidate common engineering misconceptions.

Horacio Vasquez, University of Texas, Pan American

Dr. Horacio Vasquez is an Assistant Professor in the Mechanical Engineering Department at the University of Texas-Pan American (UTPA), in Edinburg, Texas. His current research interests are in the areas of control systems, mechatronics, measurements and instrumentation, renewable energy, and engineering education.

Constantine Tarawneh, The University of Texas-Pan American

Robert D. Wrinkle, University of Texas-Pan American

Director of the Center for Survey Research and Professor, Department of Political Science. Speciality is evaluation research.

Martin William Knecht, South Texas College

Guided Discovery Modules for Statics and Dynamics

Abstract

Students struggle to conceptualize Engineering Mechanics (i.e. Newtonian Physics, Statics, and Dynamics) fundamentals because they cannot successfully visualize the effects of external loads on physical systems and/or do not intuitively comprehend the static or dynamic response. Traditionally, Engineering Mechanics courses like Statics and Dynamics have been primarily lecture-based with little experimentation. The authors contend that through the use of inquiry-based, multimodal activities, lower-division engineering students can more effectively interpret Engineering Mechanics concepts. Instructors must place emphasis on engendering properly conceived engineering intuition and contextualizing concepts and fundamentals. The authors hypothesize that by utilizing often simple, multimodal, inquiry-based exercises, instructors can better overcome misconceptions. A novel methodology termed “guided discovery” is presented herein. It borrows aspects of challenge-based and discovery learning. The method, however, is optimized for short in-class activities and homework assignments. Several modules are presented to illustrate the processes used and some preliminary results are included.

Introduction

Part of the challenge of encouraging students to think critically about Engineering Mechanics is that some view the material as “disconnected facts and formulas” as opposed to “an interconnected web of concepts”¹. There is a tendency to approach Mechanics problems by identifying the applicable equations as opposed to recognizing underlying concepts. It is not always students’ tendency to critically evaluate the information given and methodically analyze using engineering intuition. Even when they do, often times they have preconceived misconceptions that hinder effective analysis. Effort must be made to refocus students so they approach Mechanics as “an interconnected web of concepts.” Traditional pedagogical approaches do not encourage this. As such, alternative approaches must be.

Elby et al.^{1,2,3} researched the role of students’ perceptions of Physics in hindering concept mastery. The North Carolina State University Physics Education Research and Development Group, the largest physics education research group in the Nation, has developed and researched the use of animation to assess physics concepts mastery^{4,5}. Gray et al.^{6,7} developed a format for Dynamics curriculum deemed “Interactive Dynamics.” The format involved collaborative learning, computer simulations, and experimentation. Magill of Purdue University developed a series of inexpensive bench-top exercises used to demonstrate basic Mechanics principles^{8,9}. Steif and Dollár developed a series of simple experiments and web applets used to demonstrate Statics concepts^{10,11,12,13}. Everett et al.^{14,15} developed counter intuitive Dynamics examples designed to expose students’ misconceptions.

Education experts continue to urge Engineering educators to transform from a lecture-based paradigm to one that is more inquiry-based. The 2000 National Research Council report¹⁶ indicated that “[s]ixth graders in a suburban school who were given inquiry-based physics instruction were shown to do better on conceptual physics problems than eleventh and twelfth grade physics students taught by conventional methods in the same school system.” In spite of

the potential advantages for student learning, there is a limited amount of research on the use of inquiry-based learning in Statics and Dynamics.

Despite advancements, widespread reform has not taken place because of (1) a reluctance to implement pedagogical changes and (2) deeply rooted student misconceptions. The authors contend that through the use of inquiry-based, multimodal modules, students can more effectively interpret Engineering Mechanics concepts. Such modules can better engender properly conceived engineering intuition and better help contextualize concepts and fundamentals. These modules place emphasis on understanding the problem and not on simply trying to find the right answer(s).

Methods and Procedures

The methods are based in part on two multimodal modules previously piloted by Drs. Kypuros and Tarawneh for Dynamics described in¹⁷. Additionally, as described in^{18,19,20}, Dr. Kypuros has developed “virtual systems” that allow the user to modify parameters and animate the response of dynamic systems. The modules being developed also draw on the previous work of others. In particular, the modules borrow characteristics from the counter-intuitive examples developed by Everett et al.^{14,15}, the animations developed by the Physics Education Research and Development Group at North Carolina State^{4,5}, and Magill’s classroom models^{8,9}.

The modules are designed to use in place of select homework or lecture content and not simply be an addition to existing curriculum. The intent is to complement but not fully supplant existing curriculum. The modules share some common characteristics^{21,22}:

- *Inquiry-Based*. Modules, when possible, are purposely posed with “open-ended” questions that force students to demonstrate concept mastery by expressing through tasks, words, and presentation a deeper understanding of the concepts and material.
- *Cooperative-Learning*. The modules incorporate steps that require students to share knowledge, discuss answers, and arrive at conclusions through interaction.
- *Interactive*. As already mentioned, the modules require students to interact physically or virtually with the physical system to solve problems.
- *Common Misconceptions*. The modules will be designed to target already identified Statics and Dynamics misconceptions.
- *Discovery*. The modules are designed to guide students to discover underlying principles and build properly formulated engineering intuition.

In addition to having common characteristics, as illustrated in Figure 1, the modules are implemented using similar processes by Kypuros et al.²² The *overall process* involves lecture, a pre-module assessment, a primary exercise, an intermediate assessment, a secondary exercise, and a post-module assessment.

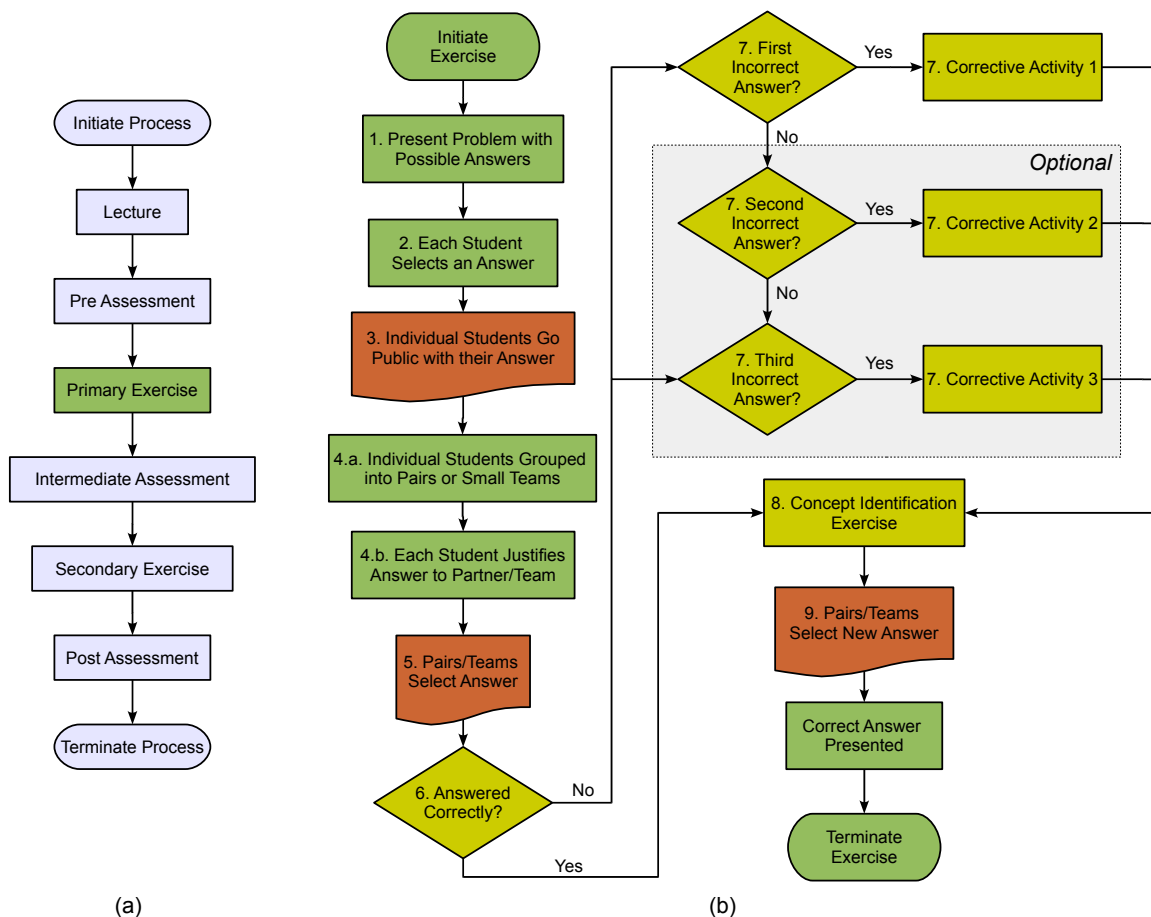

Figure 1: (a) Overall process flow chart and (b) primary exercise flow chart

The Primary Exercise Process first introduced by Kypuros and Tarawneh²¹ and further discussed by Kypuros et al.²² is flowcharted in Figure 1(b) for convenience. The numbers correlate with the steps that are detailed by Kypuros and Tarawneh²¹. The green blocks indicate general procedures. The orange blocks are steps where data can be collected for later assessment. The yellow blocks are where multimodal activities are employed within the process to insure that students arrive at the correct conclusions. The number of these activities varies and depends on the potential misconceptions and their associated answers. This process is intended to encourage students to think critically, exchange ideas, assess their answers, and correct them (if necessary).

Sample Modules

To illustrate the overall process (Figure 1(a)) and the primary exercise procedure (Figure 1(b)), two sample modules are detailed below. The first, a pulley module, will illustrate the primary exercise procedure, and the second, a 3D vector module, will illustrate overall process. This will be followed by a summary of preliminary results attained over several semesters using the 3D vector module.

A Pulley Module – Primary Exercise Procedure

The pulley module was developed to help students understand the use of pulleys to generate a mechanical advantage. Students often fail to understand that the motions of the pulleys (i.e. displacements and velocities) are interrelated through simple constraints. Furthermore, they do not always recognize that the same constraints are used to relate the forces and determine the mechanical advantage. The concepts and/or misconceptions this module is designed to address are (1) masses attached through pulley systems have interdependent motion that can be represented through simple mathematical constraints and (2) the equations used to quantify the mechanical advantage relate not only the tensions or forces but the displacements and velocities too.

Present Problem with Possible Answers. Whenever possible the problem is presented as a real-world-inspired challenge. The challenge used for the pulley module is

“You stalled your prize 6500 lb, heavy-duty, 4x4 in a creek bed at the bottom of an embankment about 15 ft away – 9 ft down and 12 ft over (refer to Figure 2). The engine will not turn over because the ignition circuit was damaged when it got wet. Unfortunately the only winch available is attached to your friend’s ATV. It is only rated at a maximum 1750 lbs and operates with a constant line speed of 15 feet per minute (FPM). However, it has plenty of cable (200 ft), and you have access to a winch kit with one heavy-duty pulley block (rated at 10,000 lbs), two light duty pulley blocks (rated at 2500 lbs), two 10-ft tow straps (rated at 20,000 lbs), and two shackles (rated at 3000 lbs). (Items are depicted in Figure 3.) Shackles and two straps may be used to attach cable, pulleys, or tow straps to the bumper of the truck. There are numerous trees that could be used to anchor the ATV and to attach tow straps with pulley blocks. From the choices provided, choose an option that will pull your truck up the embankment without exceeding the rating of any of the components used. Determine the tension in the cable and the time that will be needed to move the truck up the embankment. Also, explain any assumptions you made.”

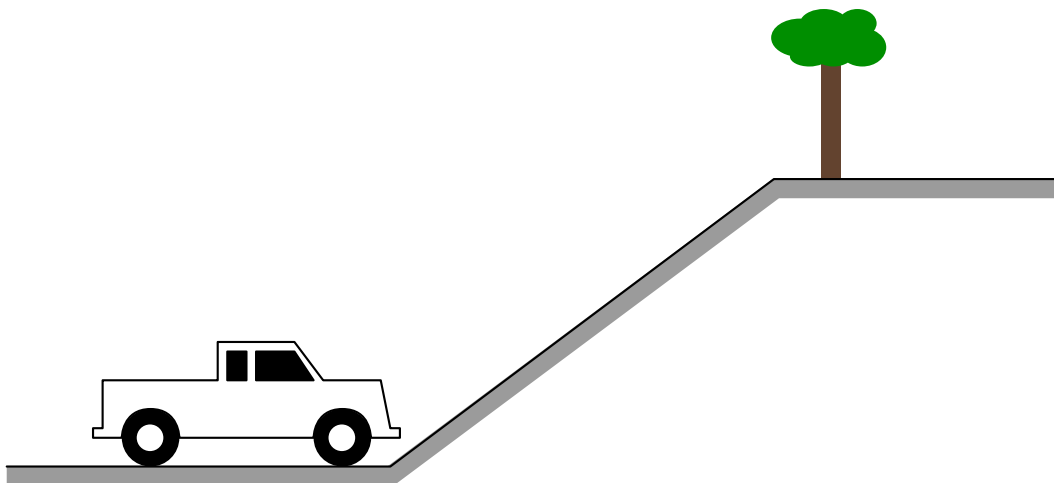

Figure 2: Truck at bottom of embankment



Figure 3: Winch kit accessories

The solutions provided are depicted in Figure 4. Of the solutions provided, (a) will result in a tension that exceeds the winch limit, (b) and (c) will work without exceeding the limits of any of the components, and (d) does result in tension within the winch limit but that exceeds the shackle rating. Many other similar answers can be readily devised. The use of two acceptable answers ((b) and (c)) emphasizes that there is no one right answer. The answer however is twofold; the pulley configuration is only part of the answer. The students must also provide the elapsed time.

Ⓜ Heavy Duty Pulley Ⓛ Light Duty Pulley Tow Strap --- Shackle

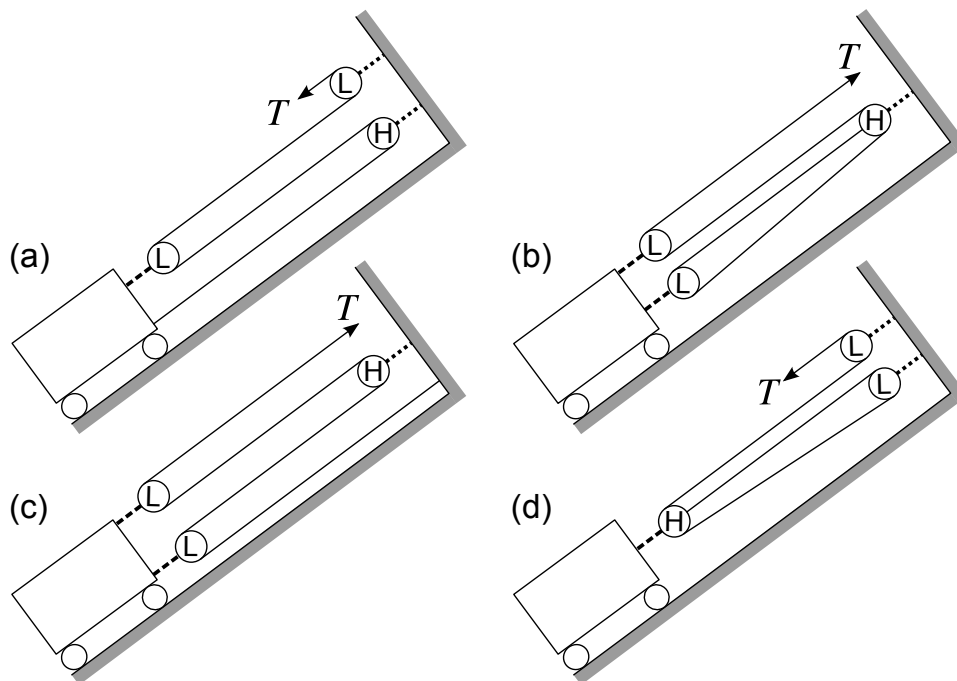

Figure 4: Possible solutions

By requiring the tension and the time required, one insures that the students make an effort to justify their answer and examine it more critically. Again, a series of seemingly plausible answers are provided for the elapsed time, e.g.

- (a) 3 minutes
- (b) 20 seconds
- (c) 15 seconds
- (d) 4 minutes

The time elapsed will depend on the solution chosen for the pulley configuration. Pulley configurations (a) and (d) require 3 minutes while (b) and (c) require 4 minutes.

Individual and Group Answers. At this point, there is no discussion about constraint equations and mechanical advantage. Such topics should have been previously covered. Students are guided through steps 2-6 of the flowchart as described by Kypuros and Tarawneh²¹. Answers are recorded at steps 3 and 6 for the individual students using student IDs but no name.

At this junction, corrective activities are used to redirect students who answered incorrectly and reinforce students who answered correctly. This can be accomplished without the instructor actually checking the answers. Students or teams can be instructed to conduct specific activities based on the answer they chose.

Corrective Activity 1 – Improper Pulley Configuration. The activity is accomplished with some inexpensive components including pulleys, rope, and spring scales as depicted in Figure 5. The student or team is tasked with devising a pulley system that minimizes the effort required to lift a backpack or book bag three feet off the ground. If the pulleys cannot be readily anchored or hung, the students themselves can serve as ceiling or ground anchors. The advantage of this is that they physically feel the strain induced by the various configurations they devise. The activity should include constraints such as a limit on the number of pulleys that can be used.



Figure 5: In-class pulley kit

Corrective Activity 2 – Inappropriate Elapsed Time. This activity is accomplished with the same items as the previous. The task, however, is slightly different. In this activity, students are required to devise a pulley configuration using no less than two pulleys that minimizes the length of rope that must be drawn to lift the backpack 3 ft. They are asked to record the length of rope

drawn and time required. Furthermore, they are instructed to pull the rope at a consistent, steady rate.

Concept Identification. At this stage, students must now identify proper concepts that should be used to arrive at the correct answers. A list of seemingly feasible concepts is provided, e.g.

- (a) Newton's Second Law
- (b) Work-Energy Principle
- (c) Constraint Equations
- (d) Particle Kinematics

Students must identify the applicable concepts from the list and justify their answer to their team.

As follow-up, students can be redirected to solutions (a) and (d) and asked what modifications would enable those solutions to work. For instance, if the shackle attaching the heavy-duty pulley to the truck were replaced with a tow strap instead, the solution would work. Moreover, it would have a shorter elapsed time than solutions (b) or (c). Additionally, the problem can be modified to address Newton's Second Law. If the motor were operated at a constant torque rather than a constant line speed, the speed would vary and the elapsed time would require more involved analysis. Newton's Second Law could be employed to determine the constant acceleration.

A 3-D Vector Module – Overall Process

Students have difficulty understanding, visualizing, and differentiating position, force, and unit vectors in 3 dimensions. Students often fail to connect numerical solutions with physical concepts. Case in point: students may miscalculate the unit vector along a direction of a supporting cord resulting in a vector that is obviously in the wrong direction. The students do not always take a moment to step back and assess if the result makes physical sense. The concepts and mathematical constructs are treated as abstract without contemplation of their physical implications.

This didactic module is designed to help students visualize vectors using a configurable system of cords to suspend a mass in three dimensions. To that end, several bench-top configurations have been devised to elucidate vector concepts. As illustrated in the photo in Figure 6(a), an experimental apparatus is used to validate results and reinforce concept mastery. The forces in the cables are measured with load cells and are compared to those theoretically calculated. This activity is designed to strengthen students' knowledge through practical application of concepts studied during the first quarter of Statics, such as position, unit vectors, free body diagrams, and equilibrium of particles.

The schematic in Figure 6(b) depicts a 3-D rendering of the sample problem with dimensions. The students are tasked with determining a unit vector along the line of action of one of the cords. The potential solutions are chosen such that the answer can be surmised based on some basic concepts: (1) unit vectors are of a unit length, (2) the positive orientation of axes changes the sign of vector components, and (3) cords apply force in tension (not compression). Students

fail to distinguish between the length of the vector and its projections along the primary axes. Moreover, they can be readily confused if the axes are not oriented with directionality similar to problems they are accustomed to in the textbook (i.e. a right-handed Cartesian coordinate system). When mistakenly arriving at a solution that implies that the vector force along a cord is in compression, students sometimes fail to stop and assess whether that makes sense.

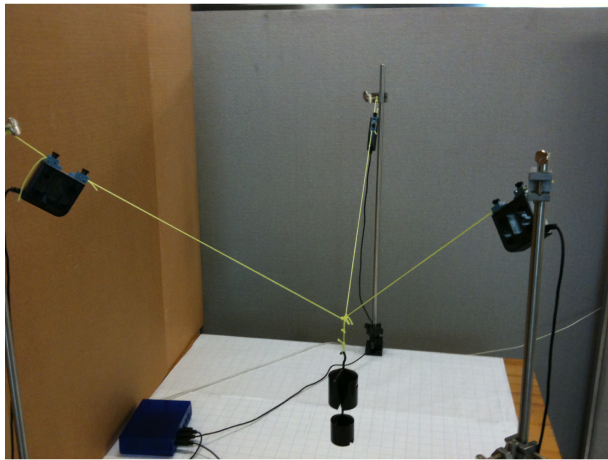

(a)

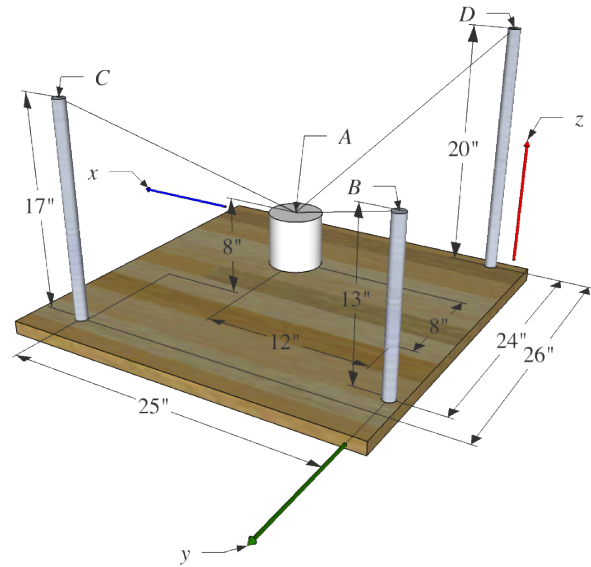

(b)

Figure 6: (a) Experimental apparatus and (b) 3D rendering

Pre-Module Assessment. In a Statics lecture, students studied how to determine unit vectors following a specific method. A pre-assessment was administered to baseline student mastery of this concept after it was covered in lecture. The pre assessment measures whether students can identify an appropriate unit vector from a list of options just by looking at a figure. This assessment requires that students not only understand what a unit vector is but also know how to identify correct vectors using a specified coordinate system. The students were posed the following question and given 3 minutes to answer:

A block is hanging at point A and held in static equilibrium by three cables as shown in the figure (see Figure 6(b)). The unit vector from point A to D could be:

- (a). $\hat{u}_{AD} = 0.47\hat{i} + 0.69\hat{j} - 0.56\hat{k}$
- (b). $\hat{u}_{AD} = -1\hat{i} - 1\hat{j} + 1\hat{k}$
- (c). $\hat{u}_{AD} = -0.47\hat{i} - 0.69\hat{j} + 0.56\hat{k}$
- (d). $\hat{u}_{AD} = 0.74\hat{i} - 0.60\hat{j} + 0.30\hat{k}$
- (e). $\hat{u}_{AD} = 1\hat{i} - 1\hat{j} + 1\hat{k}$

After administering the pre-assessment, students conducted the primary exercise.

Primary Exercise. The students were presented with more examples and 3-D vector assignments in addition to a video demonstration of the bench-top apparatus shown in Figure 6. Several photos and a 360° view were provided to help the students better visualize.

Intermediate Assessment. Changing the dimensions and/or the coordinate system can readily vary the problem. For the preliminary implementation, the pre-assessment was re-administered as an intermediate evaluation immediately following the video demonstration.

Secondary Exercise. The following was posed as a secondary exercise:

A block with a mass m is suspended from point A as depicted in Figure 6(b). Determine the forces acting on each of the cables to insure that none break. The cables can hold a maximum load of 100 N each. Estimate the factor of safety for each cable.

Students were tasked with solving this problem symbolically in terms of the mass m , and then they were shown a video of the system unloaded and loaded. The video displays the readings measured using a data acquisition system. Additionally, photos were provided which show the cord lengths measured using a yardstick.

The tensions measured by the load cells can vary from the theoretical due to measurement errors and constraints. Additionally, the apparatus may vary slightly in dimensions from the theoretical problem. As a further follow-up, students can be asked to provide reasons for the differences between the measured and theoretical values. This requires them to think critically about the problem and deduce, using their engineering intuition, causes for the variation. Moreover, it shows them that regardless of the variation, the mathematical constructs used to arrive at a theoretical solution are reasonable representations of the physical reality. At this point, students should hopefully identify cord AD as the weak link with the highest tension. Hence, it should be used to determine the factor of safety.

Post-Module Assessment. The post assessment measures how well students can transfer their new knowledge to a related problem. The following was posed as a post assessment:

A block hanging from point A is held in static equilibrium by a cable AB and struts DA and EA as shown in Figure 7. The reaction force at D could be

- (a). $\vec{F}_{DA} = (-500\hat{i} + 500\hat{j} - 1000\hat{k})\text{N}$
- (b). $\vec{F}_{DA} = (500\hat{i} - 500\hat{j} + 1000\hat{k})\text{N}$
- (c). $\vec{F}_{DA} = (500\hat{i} - 500\hat{j} - 1000\hat{k})\text{N}$
- (d). $\vec{F}_{DA} = (-500\hat{i} + 500\hat{j} + 1000\hat{k})\text{N}$
- (e). $\vec{F}_{DA} = (-1000\hat{i} + 1000\hat{j} + 1000\hat{k})\text{N}$

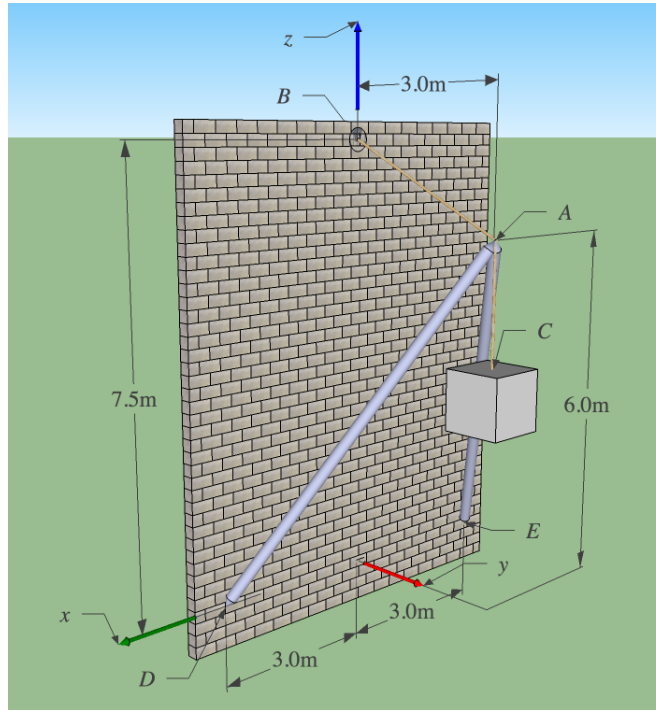

Figure 7: Vectors follow-up problem

Results

The results presented are solely for the Overall Process assessments (the orange blocks in Figure 1(a)). For these preliminary results, no data was collected for the Primary Exercise assessments. Figure 8 shows the results for the pre, intermediate, and post assessments. The sample population was 33 students. Of the 33 participants, 17, 32, and 31 respectively answered the pre, intermediate, and post-assessment questions correctly. Though the class size was over 40 students, those that either dropped the course or were absent for at least one assessment were not included in the sample population. The data is organized by final course letter grades to show if there was any discernable difference amongst A, B, C, D, and F students. All groups showed improvement. As previously described, assessments were administered before and after the module and again after a follow-up problem. As the results clearly suggest, the students showed a substantial improvement from the pre to intermediate assessments. Additionally, the students demonstrated they retained the knowledge by performing similarly on the follow-up (post) assessment. The p -values for paired T-tests comparing the Pre-Intermediate and Pre-Post are below a 5% significance level – 0.023 and 0.031, respectively. One can thus surmise that the module had a statistically significant impact on the mean score of the assessments.

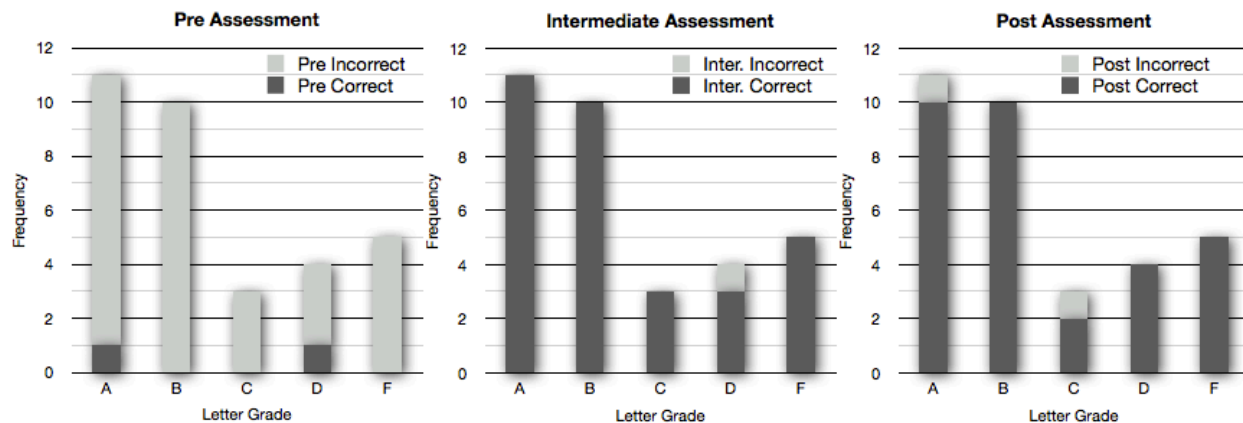

Figure 8: Vector module pre, intermediate, and post assessment results

Conclusions and Future Work

Each of the modules described herein have been implemented at least once. Some shortcomings have been identified and need to be addressed in subsequent implementations. Data has been collected for several modules to assess the overall process. However, for future implementations, data must be collected during the primary exercise as previously detailed to evaluate the impact of collaboration and student interaction.

In addition, regarding the 3D vector module, problems illustrated in Figure 6 and Figure 7 are renderings of textbook problems borrowed from Hibbeler²³ and used for the assessment. Originally, the students were just provided 2D renderings and/or photographs of the systems. The illustrations shown herein were done afterwards in Google SketchUp, which is available for free download. In the future, we can provide students a 3D rendering that they can open in SketchUp to virtually manipulate and do dimensional measurements. We can also provide an animated 360° view through a webpage. In this way, we can explore how 3D graphics might improve students' understanding of vector mechanics problems without the costs or necessity of a bench-top setup.

Acknowledgements

The authors gratefully acknowledge the support of Division of Undergraduate Education of the National Science Foundation. This research is supported by the Course Curriculum and Laboratory Improvement Program through grant number DUE-0837779.

References

- ¹ Elby, A., "Helping physics students learn how to learn," *American Journal of Physics*, 69, No. 7, 2001, pp. S54–S64.
- ² Lising, L. and Elby, A., "The impact of epistemology on learning: A case study from introductory physics," *American Journal of Physics*, 73, No. 4, 2005, pp. 372–382.
- ³ Hammer, D. and Elby, A., "Tapping epistemological resources for learning physics," *Journal of Learning Sciences*, 12, 2003, pp. 53–90.

-
- ⁴ Beichner, R., “Instructional technology research and development in a us physics education group,” *European Journal of Engineering Education*, 31, No. 4, 2006.
- ⁵ Dancy, M. H. and Beichner, R., “Impact of animation on assessment of conceptual understanding in physics,” *Physics Review Special Topics - Physics Education Research*, 2, 2006.
- ⁶ Yaeger, P. M., Marra, R., M., Gray, G. L. and Costanzo, F., “Assessing new ways of teaching dynamics: An ongoing program to improve teaching, learning, and assessment,” *Proceedings of the ASEE Annual Conference*, 1999.
- ⁷ Gray, G. L. and Costanzo, F., “Interactive dynamics: A collaborative approach to learning undergraduate dynamics,” *Proceedings of the ASEE Annual Conference*, 1999.
- ⁸ Magill, M. A., “Classroom models for illustrating dynamics principles part i. – particle kinematics and kinetics,” *Proceedings of the ASEE Annual Conference*, 1997.
- ⁹ Magill, M. A., “Classroom models for illustrating dynamics principles part ii. – rigid body kinematics and kinetics,” *Proceedings of the ASEE Annual Conference*, 1997.
- ¹⁰ Steif, P. S. and Dollár, A., “Enriching statics instruction with physical objects,” *Proceedings of the ASEE Annual Conference*, 2002.
- ¹¹ Dollár, A. and Steif, P. S., “Understanding internal loading through hands-on experiences,” *Proceedings of the ASEE Annual Conference*, 2002.
- ¹² Steif, P. S. and Dollár, A., “A new approach to teaching and learning statics,” *Proceedings of the ASEE Annual Conference*, 2003.
- ¹³ Dollár, A. and Steif, P. S., “Learning modules for the statics classroom,” *Proceedings of the ASEE Annual Conference*, 2003.
- ¹⁴ Everett, L. J. and Villa, E. Q., “Assessment results of multi-intelligence methods used in dynamics,” *Proceedings of the ASEE Annual Conference*, 2006.
- ¹⁵ Everett, L. J. and Villa, E. Q., “Increasing success in dynamics course through multi-intelligence methods and peer facilitation,” *Proceedings of the ASEE Annual Conference*, 2005.
- ¹⁶ Bransford, J. D., Brown, A. L., and Cocking, R., editors. *How People Learn: Brain, Mind, Experience, and School* (Expanded Edition). National Academies Press, 2000.
- ¹⁷ Kypuros, J. A. and Tarawneh, C., “Multimodal assessment instruments for dynamics,” *Proceedings of the ASEE-GSW Regional Conference*, 2007.
- ¹⁸ Johnson, D. W., Johnson, R. T., and Smith, K. A., *Active Learning: Cooperation in the College Classroom*, Interaction Book Company, 2006.
- ¹⁹ Freeman, R. A. and Crown, S. W., “Interactive web-based instructional modules concerning human joint mechanics using the legacy cycle,” *Proceedings of the ASEE Annual Conference*, 2001, pp. 6317–6332.
- ²⁰ Bloom, B. S., “Taxonomy of Educational Objectives: The Classification of Educational Goals,” Susan Fauer Company, Inc., 1956, pp. 201–207.
- ²¹ Kypuros, J. A. and Tarawneh, C., “Multimodal Modules for Non-Calculus-Based Engineering Mechanics Curriculum,” *Proceedings of the Frontiers in Education Conference*, 2008.
- ²² Kypuros, J. A., Tarawneh, C., Vasquez, H., Knecht, M., and Wrinkle, R., “Guided Discover Modules for Engineering Mechanics,” *Journal of Applications and Practices in Engineering Education*, 2, No. 1, 2011.
- ²³ Hibbeler, R. C., *Engineering Mechanics: Combined Statics and Dynamics*, 12th Ed., Prentice Hall, 2009.