

Fall 11-8-2016

# AN EXAMINATION OF LMX AND PROCEDURAL JUSTICE ON PERFORMANCE APPRAISAL SATISFACTION WITHIN THE CONTEXT OF A DISTRIBUTED WORKPLACE ARRANGEMENT

Debra A. Herd  
*University of Texas at Tyler*

Follow this and additional works at: [https://scholarworks.uttyler.edu/hrd\\_grad](https://scholarworks.uttyler.edu/hrd_grad)

 Part of the [Business Administration, Management, and Operations Commons](#), [Organizational Behavior and Theory Commons](#), [Organization Development Commons](#), [Performance Management Commons](#), and the [Training and Development Commons](#)

---

## Recommended Citation

Herd, Debra A., "AN EXAMINATION OF LMX AND PROCEDURAL JUSTICE ON PERFORMANCE APPRAISAL SATISFACTION WITHIN THE CONTEXT OF A DISTRIBUTED WORKPLACE ARRANGEMENT" (2016). *Human Resource Development Theses and Dissertations*. Paper 15.  
<http://hdl.handle.net/10950/492>

This Dissertation is brought to you for free and open access by the Human Resource Development at Scholar Works at UT Tyler. It has been accepted for inclusion in Human Resource Development Theses and Dissertations by an authorized administrator of Scholar Works at UT Tyler. For more information, please contact [tbianchi@uttyler.edu](mailto:tbianchi@uttyler.edu).

AN EXAMINATION OF LMX AND PROCEDURAL JUSTICE ON PERFORMANCE  
APPRAISAL SATISFACTION WITHIN THE CONTEXT OF A DISTRIBUTED  
WORKPLACE ARRANGEMENT

by

DEBRA A. HERD

A dissertation submitted in partial fulfillment  
of the requirements for the degree of  
Doctor of Philosophy  
Department of Human Resource Development

Ann Gilley, Ph.D., Committee Chair

College of Business and Technology

The University of Texas at Tyler  
October 2016

The University of Texas at Tyler  
Tyler, Texas

This is to certify that the Doctoral Dissertation of

DEBRA A. HERD

has been approved for the dissertation requirement on  
October 21, 2016  
for the Doctor of Philosophy degree

Approvals:

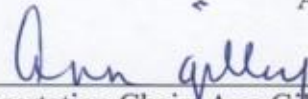

\_\_\_\_\_  
Dissertation Chair, Ann Gilley, Ph.D.



\_\_\_\_\_  
Member: Jerry W. Gilley, Ed.D.

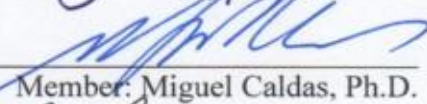

\_\_\_\_\_  
Member: Miguel Caldas, Ph.D.

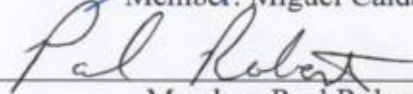

\_\_\_\_\_  
Member: Paul Roberts, Ed.D.

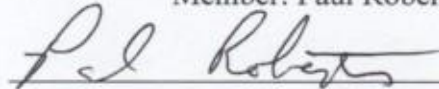

Chair, Department of Human Resource Development

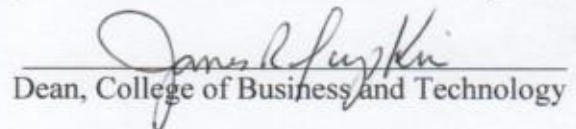

\_\_\_\_\_  
Dean, College of Business and Technology

© Copyright by Debra A. Herd 2016  
All rights reserved

## Acknowledgements

I would like to first acknowledge the members of my dissertation committee who guided me throughout this project: Dr. Ann Gilley; Dr. Jerry Gilley; Dr. Miguel Caldas; and Dr. Paul Roberts. Thank you for generously sharing your insights, examples, experience, and patience with me. I grew from every interaction. I would like to especially recognize Dr. Ann Gilley for continually putting this project into perspective for me. Her pragmatic counsel served me very well throughout this journey.

I would like to thank the University of Texas at Tyler Human Resource Development faculty for providing a stellar program, as evidenced by its renowned research, rigorous content, and balanced emphasis on research and practice. I am especially grateful to Dr. Andrea Ellinger whose teaching and coaching standard I strive to emulate; Dr. Marina Astakhova, who through her effective teaching and feedback gave me the quiet confidence to use quantitative approaches in my studies and at my work; and Dr. Greg Wang, whose feedback during the mock dissertation defense workshop helped me to refine my dissertation path.

I would like to give a big shout-out to my peers from the 2012 and 2013 doctoral cohorts at University of Texas at Tyler. The knowledge exchanges were generous, constructive, and always enjoyable. I have made professional connections I will leverage and lifelong friendships I will cherish.

I would also like to thank my employer, Comerica Bank. I very much appreciate the organization's workplace flexibility program, tuition reimbursement program, and support for employee professional growth. Most important, I appreciate my manager's, peers', and employees' encouragement and support as I applied what I had learned in the classroom to my workplace every day.

Finally, I would like to thank my family. I am grateful for my parents, Mary Lopez and Victor Landin, who, despite their limited resources and formal educations, always made it seem like anything was possible. Their everyday behaviors were evidence to me that intelligence was akin to resourcefulness and a Christ-centered heart was the key to a happy and whole life. Most of all, I would like thank my husband and son, Kevin and Sam Herd. On my behalf, they took so many things in stride the past 3 years: drive-through dinners; laundry pile-ups; very-late-night study sessions; stay-at-home vacations; and much more. They were my instructors of inspiration, generosity, and understanding. In turn, I hope that my example, especially to Sam, will give them the boldness to pursue their greatest dreams.

## Table of Contents

List of Tables .....	iv
List of Figures .....	v
Abstract .....	vi
Chapter 1: Introduction .....	1
Background to the Problem .....	1
Performance appraisal satisfaction .....	2
Social context: Distributed workplace arrangements .....	4
Factors affecting performance appraisal satisfaction.....	6
Statement of the Problem.....	7
Purpose of the Study .....	8
Theoretical Underpinning .....	8
Overview of the Design of the Study.....	10
Significance of the Study .....	10
Implications for theory.....	11
Implications for HRD research .....	11
Implications for business practice.....	12
Definition of Terms.....	13
Summary and Organization of Dissertation.....	17
Chapter 2: Review of the Literature.....	19
Introduction.....	19
Performance Appraisals: Central Components of Performance Management .....	20
A New Direction Toward Performance Appraisal Satisfaction.....	21
Achieving Performance Appraisal Satisfaction .....	24
Models of performance appraisal effectiveness.....	24
Context matters to performance appraisal satisfaction .....	26
Context involves performance appraisal employee reactions.....	28
Performance appraisal satisfaction is an employee reaction.....	30
Leader–member exchange quality .....	30
Organizational justice .....	33
Organizational justice theory .....	34
Procedural justice theory.....	36
Procedural justice and social context.....	38
Procedural justice, LMX, and performance appraisals .....	38
The Social Context of Distributed Workplace Arrangements .....	40
The changed workplace: A distributed workforce.....	40
Four features of distributed work.....	43
Performance Appraisal Challenges in a Distributed Workplace Arrangement .....	44
Lack of media richness .....	47
Lack of feedback (communication) frequency .....	50
Extent of the distributed workplace arrangement .....	51

Gaps That Require Further Research.....	52
The targeted gap.....	53
Summary of Chapter 2.....	53
 Chapter 3: Research Design and Methodology .....	 55
Introduction.....	55
Purpose of the Main Study.....	55
Two Pilot Studies.....	55
Overview of Pilot Study 1.....	56
Study sample.....	56
Measures .....	57
Performance appraisal satisfaction .....	57
Leader–member exchange .....	57
Procedural justice.....	57
Descriptives and correlations.....	58
Assumptions testing.....	58
Four-step mediation testing.....	60
Overview of Pilot Study 2.....	62
Analyses and results.....	62
Discussion.....	69
Lessons Learned From the Pilot Studies.....	71
Main Study Theory and Hypotheses.....	71
Main Study Design .....	74
Main Study Population and Sample.....	75
Main Study Measures .....	76
Performance appraisal satisfaction .....	76
Leader–member exchange .....	76
Procedural justice.....	76
Perceived media richness.....	77
Communication frequency.....	77
Extent of distributed workplace arrangement.....	77
Main Study Control Variables .....	77
Main Study Data Collection Procedures.....	78
Main Study Data Preparation.....	80
Main Study Data Analysis Procedures .....	80
Main Study Reliability and Validity.....	81
Main Study Assumptions and Limitations.....	82
Assumptions.....	82
Limitations of the design .....	82
Main Study Ethical Considerations .....	83
Summary of Chapter 3.....	83
 Chapter 4: Results.....	 84
Introduction.....	84
Data Collection and Sample Characteristics.....	84
Reliability of the Measures .....	88
Correlation Coefficients.....	88



Assumptions Testing.....	89
Hypothesis Testing.....	93
Hypotheses 1 and 2 .....	93
Hypothesis 3.....	95
Hypotheses 4 and 5 .....	97
Summary of Chapter 4 .....	100
Chapter 5: Discussion .....	102
Introduction.....	102
Discussion of the Results .....	102
Hypotheses 1 and 2 .....	102
Hypothesis 3.....	104
Hypotheses 4 and 5 .....	107
Implications of the Study .....	110
Implications for theory.....	110
Implications for research.....	110
Limitations .....	115
Suggestions for Future Research .....	116
Summary of Chapter 5 .....	118
References.....	119
Appendix A: Permission to Use Performance Appraisal Satisfaction Scale .....	142
Appendix B: Permission to Use Procedural Justice Scale .....	144
Appendix C: Permission to Use Leader-Member Exchange Scale .....	145
Appendix D: Permission to Use Perceived Media Richness Scale.....	146
Appendix E: Performance Appraisal Satisfaction Measure.....	148
Appendix F: Leader-Member Exchange Measure .....	149
Appendix G: Procedural Justice Measure .....	151
Appendix H: Perceived Measure Media Richness Measure.....	152
Appendix I: Communication Frequency Measure .....	153
Appendix J: Extent of Distributed Workplace Measure .....	154
Appendix K: Participant Recruitment Email .....	155
Appendix L: Research Survey Instrument .....	156
Appendix M: Informed Consent .....	169
Appendix N: University of Texas at Tyler Institutional Review Board Approval .....	170

## List of Tables

Table 1 <i>Means, Standard Deviations, and Correlations</i> .....	58
Table 2 <i>Summary of Regression Analysis for LMX as a Predictor for Performance Appraisal Satisfaction</i> .....	59
Table 3 <i>Summary of Regression Analysis for LMX as a Predictor for Procedural Justice</i> .....	59
Table 4 <i>Summary of Regression Analysis for Procedural Justice as a Predictor for Performance Appraisal Satisfaction</i> .....	59
Table 5 <i>Testing for Mediator Effects on Performance Appraisal Satisfaction Using Hierarchical Regression Using Control Variables</i> .....	61
Table 6 <i>Testing for Mediator Effects on Performance Appraisal Satisfaction Using Hierarchical Regression Without Control Variables</i> .....	61
Table 7 <i>Fit Indices for Measurement Models</i> .....	63
Table 8 <i>Pattern and Structure Coefficients for Three-Factor Correlated Model</i> .....	65
Table 9 <i>Implied Correlations, Average Variance Extracted, and Composite Reliability</i> .....	66
Table 10 <i>Fit Indices for Structural Models</i> .....	68
Table 11 <i>Fit Indices for Structural Models With Deleted Item Models</i> .....	68
Table 12 <i>Frequencies and Percentages for Demographic Variables</i> .....	85
Table 13 <i>Descriptive Statistics for Composite Variables</i> .....	88
Table 14 <i>Cronbach's Alpha Reliability for Composite Scores</i> .....	88
Table 15 <i>Correlation Coefficients</i> .....	89
Table 16 <i>Hierarchical Regression Predicting LMX</i> .....	95
Table 17 <i>Hierarchical Regression Predicting Procedural Justice</i> .....	98
Table 18 <i>Hierarchical Regression Predicting Performance Appraisal Satisfaction</i> .....	100
Table 19 <i>Summary of Hypotheses Results</i> .....	101

## List of Figures

Figure 1. Conceptual model of the moderating effect of distributed workplace arrangement on LMX and procedural justice on performance appraisal satisfaction. ....	9
Figure 2. Pilot Study 1 and 2 conceptual model of the mediating effect of procedural justice on LMX and performance appraisal satisfaction. ....	56
Figure 3. Pilot Study 2 measurement model. ....	64
Figure 4. Pilot 2 study measurement model with estimates. ....	67
Figure 5. Normal P-P plot (Hypotheses 1 and 2). ....	90
Figure 6. Normal P-P plot (Hypothesis 3). ....	90
Figure 7. Normal P-P plot (Hypotheses 4 and 5). ....	91
Figure 8. Scatterplot (Hypotheses 1 and 2). ....	91
Figure 9. Scatterplot (Hypothesis 3). ....	92
Figure 10. Scatterplot (Hypotheses 4 and 5). ....	92
Figure 11. Conceptual model of Hypotheses 1 and 2. ....	103
Figure 12. Conceptual model of Hypothesis 3. ....	105
Figure 13. Conceptual model of Hypotheses 4 and 5. ....	107

## **Abstract**

### **AN EXAMINATION OF LMX AND PROCEDURAL JUSTICE ON PERFORMANCE APPRAISAL SATISFACTION WITHIN THE CONTEXT OF A DISTRIBUTED WORKFORCE ARRANGEMENT**

Debra A. Herd

Dissertation Chair: Ann Gilley, Ph.D.

The University of Texas at Tyler  
October 2016

Trends in the current literature emphasize the role of organizational context in employee performance appraisal processes (e.g., Levy & Williams, 2004; Pichler et al., 2015). Social context is a type of organizational context. Using hierarchical regression techniques and data from 138 U.S.-based employees, the study examined the social context of distributed workplace arrangements and the related implications of media richness and communication frequency in relation to leader–member exchange (LMX), procedural justice, and performance appraisal satisfaction. Research has revealed that manager–employee relationships and procedural justice perspectives positively influence performance appraisal satisfaction. However, researchers have yet to explore the impact distributed workplace arrangements have on these relationships. Workplace arrangements have changed and are increasingly more distributed, remote, and virtual. Additionally, some organizations have shifted their performance appraisal programs toward more frequent, informal, and developmental feedback approaches (Buckingham & Goodall, 2015) in the hope of achieving greater performance appraisal satisfaction. Some employees working in distributed workplace arrangements may find it more difficult to achieve performance appraisal satisfaction due to a lack of information richness and less communication

frequency (Cascio, 2000; Gordon & Stewart, 2009) despite the strength of the relationship they may have with their manager and their personal justice perspectives. The study's results suggest that a distributed workplace arrangement does not significantly weaken the relationships between LMX, procedural justice, and performance appraisal satisfaction. Advances in technology and communication enable skilled managers to overcome distributed workplace challenges and shift toward using developmental performance feedback approach for all employees.

*Key words:* distributed workplace, leader–member exchange, procedural justice, performance appraisal, performance appraisal satisfaction, media richness, telecommuting, virtual work

## **Chapter 1: Introduction**

### **Background to the Problem**

The leaders of many organizations believe their performance management practices are not effective (Buckingham & Goodall, 2015; Cunningham, 2015; Morris, 2014). This belief is due in part to dissatisfaction with performance appraisals by managers and employees (Pichler et al., 2015). The dissatisfaction is often related to the laborious tasks associated with performance management or the perceived lack of transparency and fairness concerning its components (Dusterhoff, Cunningham, & MacGregor, 2014). The degree of perceived fairness is related to the quality of leader–member exchange (LMX), which involves, among other things, trust, information richness, and communication frequency between managers and employees (Pichler, 2012; Pichler et al., 2015). Consequently, a manager’s inability to provide timely and robust performance feedback to his or her employees is a deterrent to performance appraisal satisfaction (Gordon & Stewart, 2009).

When managers and employees work at different locations, the challenge of providing performance feedback is even more difficult (Cascio, 2000). Different workplace arrangements for managers and employees have proliferated and have become the norm for getting work done (Maurer, 2015). Social contextual factors such as distributed workplace arrangements influence satisfaction levels for social science topics, including performance management, yet these factors have not been fully explored (Levy & Williams, 2004; Pichler, 2012).

Given the dissatisfaction with performance management practices, some organizations are shifting toward more frequent, informal, and developmental feedback techniques (Buckingham & Goodall, 2015). However, if distributed workplace arrangements are not taken

into consideration, organizations will likely continue to experience dissatisfaction with their performance management programs and appraisals.

**Performance appraisal satisfaction.** Performance management is a strategic business endeavor (Aguinis, Joo, & Gottfredson, 2012) and is one of the most important functions that human resource (HR) professionals perform (Aguinis, 2013; Murphy & Cleveland, 1995). Performance management involves identifying, assessing, measuring, and developing employee performance and aligning these efforts with the goals of the organization (Aguinis, 2013). Managers who practice effective performance management have stronger results compared to those who do not and have at least 50% less employee turnover, 10 to 30% higher customer satisfaction ratings, and twice the net profits (Pulakos, Mueller-Hanson, O’Leary, & Meyrowitz, 2012).

Performance management includes a set of unstructured events dispersed throughout the year (Spence & Keeping, 2011), with the goal to improve employee performance (DeNisi & Pritchard, 2006). Coens and Jenkins (2002) described a performance appraisal as a session or a required event in which, for a defined period, an employee’s job performance and behaviors are rated or described by a person other than the employee, and the results are kept and used by the organization. In theory, the performance appraisal fits within the larger realm of performance management and thus should focus on performance improvement (Spence & Keeping, 2011). The performance appraisal is a central component of the performance management system and process (Gruman & Saks, 2011), which Grote (2011) noted has a greater impact on careers and work lives than any other management process.

Pichler et al. (2015) detailed that performance appraisals are one of the most pervasive management tools used in organizations and are among the most important HR systems (Cawley,

Keeping, & Levy, 1998) because they represent critical decisions integral to a variety of HR decisions and outcomes (Judge & Ferris, 1993). Thus, they are one of the most commonly studied subjects in management and organizational literature (Arvey & Murphy, 1998; Murphy & Cleveland, 1995). The decisions that result from performance appraisals serve a variety of organizational purposes (Jawahar, 2007), such as compensation (e.g., salary increases, bonuses), legal defense, and job assignment decisions (e.g., promotions, transfers, demotions). The performance appraisal also supports employee development by identifying strengths and weaknesses, creating opportunities for performance feedback, and facilitating discussions with managers (Tziner, Joanis, & Murphy, 2002).

However, Hickman (2001) found that 80% of U.S. organizations have some type of a performance appraisal and, of those, 90% were dissatisfied with their practices. Performance appraisal dissatisfaction, defined as discontentment or unhappiness with the performance appraisal or events leading up to or after the performance appraisal discussion (Grote, 2011), exists on many levels. Kondrasuk (2012) found 76 problems with performance appraisals and placed them into four categories: the purpose of the performance appraisal; those involved with the performance appraisal; what is measured and how; and the system and process of the performance appraisal. In a 2012 survey, over 50% of employees reported performance appraisals did not provide an accurate assessment of their work, and nearly 25% said they dreaded performance appraisals (Pulakos et al., 2012). Spence and Keeping (2011) described the performance appraisal as a “daunting and painful experience” (p. 1) for both managers and employees. Kline and Sulsky (2009) noted the rite of conducting performance appraisals triggered dread and apprehension among even the most seasoned managers. They were uncomfortable having to inform employees about their performance, and the performance



appraisal remained the most contentious aspect of the performance management process (Gordon & Stewart, 2009). Managers were not alone; employees also regarded the performance appraisal with anxiety and dislike (Brown, Hyatt, & Benson, 2010). The performance appraisal was regarded as the most dreaded, intimidating, and painful experience for managers and employees (Posthuma & Campion, 2008; Spence & Keeping, 2011).

Dissatisfaction with performance appraisals is common (Pulakos, Hanson, Arad, & Moya, 2015; Pulakos & O’Leary, 2011), and there is no general agreement about a solution to the predicament. Although practitioner literature is replete with advice and anecdotal evidence about useful methods (Grote, 2000, 2011; Pulakos & O’Leary, 2011), the creation of effective performance management systems, processes, and performance appraisals largely remains an unrealized goal among researchers and practitioners (Levy & Williams, 2004).

If managers are expected to use performance appraisals to encourage employee performance, employees should view the appraisals as positive and satisfying events. Employees who are more satisfied with the performance appraisal process, which includes the appraisal event, are more likely to agree with their appraisal and view it as beneficial to improving their performance and development. Positive employee satisfaction with performance appraisals is linked to an improved “understanding between the manager and employee and motivation to improve performance and actual improvement” (Dusterhoff et al., 2014, p. 266). An employee’s dissatisfaction with it is related to greater job dissatisfaction, a lower commitment to the organization, and increased intentions to leave (Brown et al., 2010).

**Social context: Distributed workplace arrangements.** Adding complexity to the performance management problem, performance appraisals occur in a social context (Murphy & Cleveland, 1995), and within this context, employees react to performance appraisals in a variety

of ways. Employee reactions are one of the most important criteria to performance appraisal researchers (Balzer & Sulsky, 1990) because employee reactions predict future motivation and performance (Nathan, Mohrman, & Milliman, 1991). Performance appraisal satisfaction is one of the identified employee reactions to a performance appraisal (Pichler, 2012; Pichler et al., 2015).

Organizations and managers struggle with performance appraisals (Grote, 2011; Kondrasuk, 2012; Pulakos et al., 2012; Spence & Keeping, 2011). Thus, performance appraisals and the achievement of performance appraisal satisfaction could be more difficult when employees work at a distance from their managers. The need for a flexible and distributed workforce and opportunities brought about by information and communication technology have resulted in an increase in the number of employees working away from a central office (Hakonen & Lipponen, 2008; Purvanova, 2014). *Distributed work* is work done “under reduced supervision with others at some physical distance, facilitated by communication technology” (Rockmann & Pratt, 2015, p. 6). It is also referred to as telecommuting, telework, remote work (Golden, Barnes-Farrell, & Mascharka, 2009), geographically dispersed or geographically distributed work (Purvanova, 2014), and virtual work (Golden et al., 2009). In addition, the image of an employee working offsite all the time is no longer accurate. Thus, the extent an employee works away from the office must also be taken into consideration (Kacmar, Witt, Zivnuska, & Gully, 2003).

Within the social context of a distributed workplace arrangement, performance management is the biggest management challenge, and it requires managers to do many performance management activities well (Cascio, 2000). Managers have to use various information and communication technologies (e.g., e-mail, telephone, video) to identify, assess,

measure, and develop employees' performance. A lack of face-to-face performance feedback is common for distributed employees, as managers have fewer opportunities to observe their employees' performance directly (Daft & Lengel, 1986).

**Factors affecting performance appraisal satisfaction.** Given the general dissatisfaction of performance appraisals and the challenge of applying performance management practices to distributed employees, it would seem that performance appraisal satisfaction is difficult to achieve. Nonetheless, researchers have found performance appraisal satisfaction is contingent upon certain factors, including the strength of the manager–employee relationship (Wittmer, Martin, & Tekleab, 2010). This relationship is explained by LMX theory and involves the perceived levels of communication, involvement, and commitment that an employee feels from a manager (Graen & Uhl-Bien, 1995).

In addition, researchers have determined that a relationship exists between performance appraisal satisfaction and organizational justice. Employees have higher performance appraisal satisfaction when they perceive the performance management process, which includes the performance appraisal, as fair (Caputo, 2007; Dusterhoff et al., 2014; Foster, 2006; Thurston, 2001; R. Wilson, 2011; Wittmer et al., 2010). Fairness associated with procedures, processes, and policies is explained by procedural justice, which is a component of the organizational justice construct (Colquitt, 2001). However, previous studies concerning distributed employees have largely ignored the role of procedural justice (Hakonen & Lipponen, 2008). Additionally, research has shown that perceived justice is especially important when employees experience high levels of uncertainty, and because uncertainty and ambiguity are typical of distributed employees, these employees look for information about procedural justice to reduce their uncertainty (Hakonen & Lipponen, 2008). Compounding the situation further, these employees

mainly interact with their managers via information and communication enabled by technology, so they must rely on a limited number of procedural justice cues (Hakonen & Lipponen, 2008).

Thus, the factors contributing to performance appraisal satisfaction between collocated and distributed employees are not necessarily the same (Potter & Balthazard, 2002). Researchers and practitioners have not delineated these distinct factors. Consequently, a more complete understanding of performance appraisal satisfaction within a social context, such as a distributed workplace arrangement, is necessary (Thomas & Bretz, 1994).

### **Statement of the Problem**

Although the use of performance feedback tactics as proxies for performance appraisals has increased in organizations, researchers have yet to determine to what extent these efforts will be effective in the contemporary reality of distributed workplace arrangements. Performance appraisal satisfaction is essential considering the importance organizations place on the activity to drive results and make decisions (Aguinis et al., 2012; Shahmehr, Safari, Jamshidi, & Yaghoobi, 2014). Employee satisfaction with performance appraisals is linked to an improved understanding between managers and employees, motivation to improve performance, and actual improvement (Burke, Weitzel, & Weir, 1978). Employee satisfaction is also related to the strength of the manager–employee relationship and procedural justice (Dusterhoff et al., 2014; Pichler et al., 2015). The studies reviewed did not use or mention distributed employees. Given the growth of distributed workplace arrangements, the performance feedback challenges of virtual manager–employee relationships, and the dissatisfaction with performance appraisals, the perspective of employees using distributed workplace arrangements is worthy of study.

The question not adequately addressed in the literature is the extent to which performance appraisal employee reactions, in this case performance appraisal satisfaction, are a function of

the exchange quality and procedural justice relationship when a distributed workplace arrangement exists. This question is important because, according to LMX theory, the exchange of resources, which include richness and frequency of communication, is essential to the quality of the manager–employee relationship (Wayne, Shore, Bommer, & Tetrick, 2002) and thus to performance appraisal satisfaction.

### **Purpose of the Study**

The purpose of this study was to examine the social context relationship of distributed workplace arrangements on performance appraisal satisfaction through LMX theory, procedural justice, media richness, and communication frequency.

### **Theoretical Underpinning**

Given the factors affecting performance appraisal satisfaction, this study was underpinned by leadership, justice, and communication theories. Various research studies related to performance appraisal satisfaction are explained using LMX theory and organizational justice theory (Dusterhoff et al., 2014; Gruman & Saks, 2011; T. Kim & Holzer, 2014; Pichler et al., 2015; Saks & Gruman, 2011). The focus of LMX, a leadership theory, is the relationship between a manager and an employee, each of which differs in quality (Graen & Uhl-Bien, 1995). Researchers have found that the stronger the exchange, the higher the performance appraisal satisfaction (Dusterhoff et al., 2014; Gruman & Saks, 2011; T. Kim & Holzer, 2014; Pulakos et al., 2012).

Organizational justice is the study of employees' perceptions of fairness in organizations (Lau, 2014), and procedural justice is a component of organizational justice fostered when employees believe managers adhere to stated guidelines, policies, and procedures and when employees have a voice and appeal process (Colquitt, Lepine, & Wesson, 2009). Researchers

have concluded that procedural justice is a facilitator of performance appraisal satisfaction (Dusterhoff et al., 2014; Gilliland & Hale, 2005; T. Kim & Holzer, 2014; Lundquist, 2014; Turgut & Mert, 2014).

Media richness theory fosters the notion that the communication interchange of distributed manager–employee dyads versus collocated dyads is inferior. This theoretical construct maintains that face-to-face communication is superior to all other communication, including e-mail, telephone, and videoconferencing, because it has the most communication pathways and thus allows for the transmission of various types of information (Daft & Lengel, 1986; Purvanova, 2014). Thus, LMX, procedural justice, and performance appraisal satisfaction are strained when a distributed workplace arrangement exists. See Figure 1 for a view of the conceptual model.

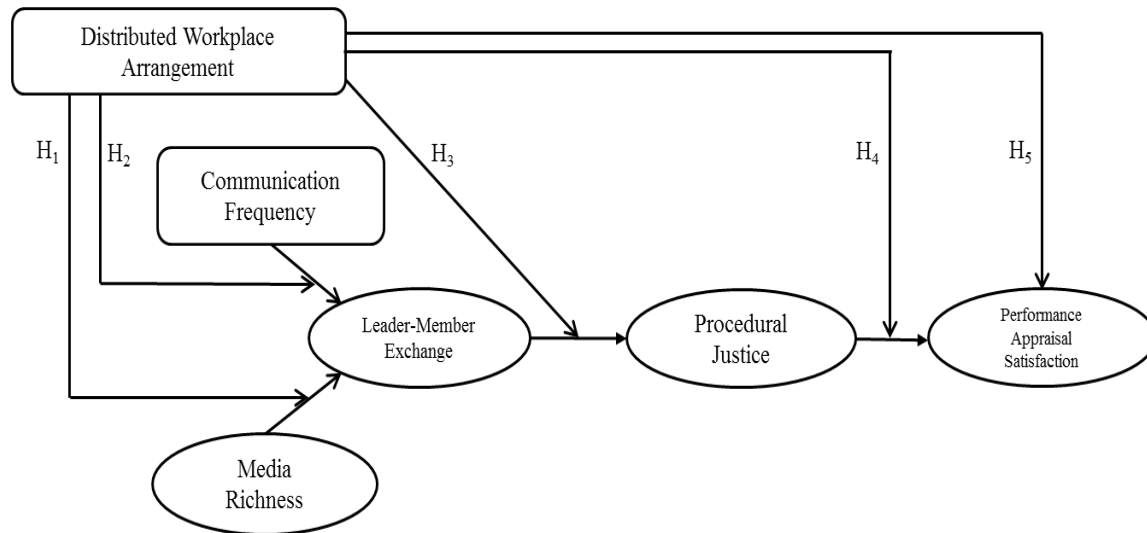

*Figure 1.* Conceptual model of the moderating effect of distributed workplace arrangement on LMX and procedural justice on performance appraisal satisfaction.

## **Overview of the Design of the Study**

This study was supported by two pilot studies. Both examined the LMX, procedural justice, and performance appraisal satisfaction relationships. One pilot study included hierarchical regression techniques and the other included structural equation modeling. Their details appear in Chapter 3. The design of this study included the addition of a distributed workplace arrangement variable as a moderator to communication richness and frequency, LMX, procedural justice and performance appraisal satisfaction. The study used a quantitative strategy using hierarchical regression techniques.

## **Significance of the Study**

The relevance of performance appraisal satisfaction and its social context is significant because researchers have determined that performance management is a critical aspect of HR and HR development (HRD; Egan, 2011; Gilley, Egglund, & Gilley, 2002; Gilley & Gilley, 2002; Swanson & Arnold, 1996; Wang & Swanson, 2008). HRD is a process for developing individual abilities to improve performance (Knowles, Holton, & Swanson, 2014).

Performance appraisal is the critical element (Gruman & Saks, 2011) that drives key HR decisions (Kondrasuk, 2012) within performance management. However, its usefulness in managing employee and organizational performance has been questioned for many years (Glover, 1996; Kondrasuk, 2012; Pulakos & O'Leary, 2011; Thomas & Bretz, 1994). Given the importance of performance management to HRD, the degree to which organizations and employees are satisfied with performance appraisals makes them relevant.

Performance management practices are changing in part because social context (e.g., employee reactions and distributed workplace arrangements) is being recognized as having compelling effects on these practices (Dusterhoff et al., 2014; Levy & Williams, 2004; Pichler et

al., 2015). However, if HRD practitioners apply new performance appraisal practices with no regard to social context, interventions such as performance coaching and feedback will be at risk, and performance appraisal satisfaction will likely not be achieved. Swanson and Arnold (1996) noted that there was no place for the uninformed application of HRD solutions. This study provides a fuller explanation concerning the phenomena of social context on performance management and performance appraisal satisfaction and the ways HRD practitioners can leverage and use the contemporary reality of distributed employees in performance management solutions.

**Implications for theory.** With regard to theory, this study supported the strong correlations involving LMX, procedural justice, and performance appraisal satisfaction. To add to the existing knowledge of these constructs, in the presence of distributed workplace arrangements, these relationships held firm, reinforcing the constructs' principles. Further, when media richness and communication frequency were added to the hypothesized model, the constructs held firm. This could mean that regardless of the workplace arrangement (distributed or nondistributed), the constructs of media richness, LMX, procedural justice, and performance satisfaction are not significantly affected.

**Implications for HRD research.** This study made two important contributions to HRD research. It expanded the existing research literature by adding distributed workplace arrangement to the list of contextual facets in which performance appraisal satisfaction is viewed. This study's results demonstrated that workplace arrangement does not significantly lessen employees' perception of procedural justice on performance appraisal satisfaction regardless of LMX quality. Second, this study supported prior research by Dusterhoff et al. (2014) and Pichler et al. (2015). It demonstrated the positive relationships between LMX,



procedural justice, and performance appraisal satisfaction. Additionally, procedural justice was shown to be a strong mediator between LMX and performance appraisal satisfaction.

**Implications for business practice.** This study had implications for HRD and related business practices. First, HRD practitioners must understand how different workplace arrangements could affect performance management programs given their importance to organizations (Aguinis, 2013; Judge & Ferris, 1993; Murphy & Cleveland, 1995).

Additionally, because the achievement of effective performance management programs remains an unrealized goal (Levy & Williams, 2004), organizations can perhaps proceed with more confidence that new techniques (i.e., more frequent feedback) in conducting performance appraisals could work for organizations that use distributed workplace arrangements. Also, HRD practitioners should keep in mind that some researchers (Pichler, 2009, 2012; Pichler et al., 2015) consider employee reactions to be the true measures of performance appraisal effectiveness, with organizational justice theory as the bridge between appraisal context and appraisal reactions. Regarding these reactions, procedural justice has been found to increase an employee's level of performance appraisal satisfaction directly and via the manager–employee relationship. This begins with HRD practitioners applying justice principles to all performance management activities such as policies, procedures, employee communication, and manager training. Next, it would be prudent of HRD practitioners to consider managers' communication and feedback abilities in the performance appraisal process; otherwise, employees will not buy into the program (Panggabean, 2001; Wittmer et al., 2010).

Finally, whether an employee and manager are collocated or geographically distributed, procedural justice and LMX play a role in the type of feedback and performance evidence (direct or nondirect) managers provide to their employees (e.g., Golden et al., 2009; Kurland & Cooper,

2002; Murphy & Cleveland, 1995). Managers are the key players in these activities. HRD practitioners should give careful consideration to the selection, training and development of managers. Consequently, organizations can leverage productive manager-employee relationships that lead toward the achievement of organizational goals.

### **Definition of Terms**

**Accuracy.** One of the six conditions of procedural justice. Maintains that decisions should be of high quality and be made with informed views. Procedures that disregard pertinent information or use inappropriate methods are likely to yield inaccurate and unfair decisions (Leventhal, 1980).

**Bias suppression.** One of the six conditions of procedural justice. Refers to the fact that a procedure can either intensify the tendency to follow biases and prejudice or safeguard, or at least support, objectivity and neutrality (Leventhal, 1980).

**Collocated.** “Individuals who are physically located close together and can work in face-to-face contexts” (Brewer, 2015, p. 8).

**Consistency.** One of the six conditions of procedural justice. States that procedures should be consistent across time and people (Leventhal, 1980).

**Correctability.** One of the six conditions of procedural justice. Requires that opportunities exist for the mediation or reversal of decisions (Leventhal, 1980).

**Distal variables.** One of two types of social context variables for performance appraisals. Variables that involve organizational culture, climate, goals, HR strategies, external economic factors, technological changes, and workforce composition (Levy & Williams, 2004).

**Distributed work.** Work done “under reduced supervision with others at some physical distance, facilitated by communication technology” (Rockmann & Pratt, 2015, p. 6). Also

referred to as telework, telecommuting, remote work (Golden et al., 2009), geographically dispersed or geographically distributed work (Purvanova, 2014), and virtual work (Golden et al., 2009).

**Distributed workplace arrangement (DWA).** An organizational structure within which an employee engages in distributed work (Golden et al., 2009).

**Distributive justice.** One of the four factors of organizational justice. Deals with the fairness of decision and distribution outcomes (Z. S. Byrne & Cropanzano, 2001; Colquitt, Conlon, Wesson, Porter, & Ng, 2001).

**Ethicality.** One of the six conditions of procedural justice. Requires that behavior is ethical and abides by the norms of a situation or organization. Violations of these conditions lead to perceptions of unfairness, even if the actual procedural outcomes are thought to be just and suitable (Umlauf & Dalbert, 2012).

**Feedback environment.** Defined as “the contextual aspects of the day-to-day supervisor-subordinated and coworker-coworker feedback process” (Steelman, Levy, & Snell, 2004, p. 166).

**Informational justice.** One of the four factors of organizational justice. Pertains to the perceived fairness of the information provided by managers and leaders during the course of decision making (Colquitt et al., 2009).

**In-groups.** Within the LMX theoretical framework, in-groups are employees who enjoy richer work duties and have manager–employee relationships distinguished by loyalty, open communication, and information sharing (Dienesch & Liden, 1986).

**Interpersonal justice.** One of the four factors of organizational justice. Reflects the perceived fairness of the treatment received by employees from managers and organizational leaders (Colquitt et al., 2009).

**Leader–member exchange (LMX) theory.** Suggests that managers interact, respond to, and treat subordinate employees differently depending upon their favored status and that these interactions differ by quality and by employee (Dansereau, Graen, & Haga, 1975; Gerstner & Day, 1997; Graen & Uhl-Bien, 1995; Wayne, Shore, & Liden, 1997).

**Media richness theory.** Puts forth that face-to-face interactions are the richest form of information, as they contain a complete variety of informational cues (e.g., voice tone, nonverbal behaviors, and contextual background indicators) (Daft & Lengel, 1986). Also known as information richness theory (Golden et al., 2009).

**Organizational justice.** The application and implication of the equity justice principle in organizational settings (Colquitt et al., 2001).

**Out-groups.** Within the LMX theoretical framework, employees who are less trusted, given less meaningful assignments, and receive more formal communication. Their job obligations extend only to their formal duties (Liden & Maslyn, 1998).

**Performance appraisal.** A session, a required event, in which, for a defined period, an employee's job performance and behaviors are rated or described by a person other than the employee, and the results are kept and used by the organization (Coens & Jenkins, 2002).

**Performance appraisal dissatisfaction.** Discontentment or unhappiness with a performance appraisal or with events leading up to or after a performance appraisal discussion (Grote, 2011).

**Performance appraisal employee reaction.** The “individual-level attitudinal evaluations of and responses to the performance appraisal process” (Pichler, 2012, p. 710). The six performance appraisal employee reactions are accuracy, fairness, procedural justice, motivation to improve, utility, and satisfaction (Pichler, 2009, 2012).

**Performance appraisal satisfaction (PAS).** An employee’s reaction to a performance appraisal. Pichler (2009) noted, “The overall valuation of how satisfied the employee is with his or her performance appraisal” (p. 7).

**Performance management.** A set of unstructured events dispersed throughout the year with a goal to improve employee performance (Spence & Keeping, 2011). Generally considered associated with creating a shared vision of the purpose and aims of the organization, helping each individual employee to understand and recognize their part in contributing to them, and in so doing to manage and enhance the employee performance of both individuals and the organization. (Fletcher & Williams, 1996, p. 169)

Performance management is also referred to as a performance management system and a performance management process (Decramer, Smolders, & Vanderstraeten, 2013).

**Procedural justice (PJ).** One of the four factors of organizational justice. Emphasizes the significance of procedures, facilitating decision making on outcomes, and the distribution of resources to perceived fairness (Colquitt, 2001; Greenberg, 1990; Leventhal, 1980).

**Process proximal variables.** One of two types of proximal variables. Includes processes that have a direct impact on how the performance appraisal is conducted (Levy & Williams, 2004). Examples of process proximal variables are the manager–employee relationship, performance expectancies, and task characteristics (Fletcher & Williams, 1996).

**Proximal variables.** One of two types of social context variables for performance appraisals. Variables that affect the timing and purpose of the performance appraisal (Levy & Williams, 2004).

**Representativeness.** One of the six conditions of procedural justice. Requires that decision making be collaborative and involved parties are represented in the decision-making process (Leventhal, 1980).

**Structural proximal variables.** One of two types of proximal variables. Variables that deal with the configuration of the performance appraisal itself, including its features, frequency, standards, and legitimacy (Fletcher & Williams, 1996; Levy & Williams, 2004).

### **Summary and Organization of Dissertation**

This chapter included the background to the problem, a statement of the problem, and the purpose of the study. It also included the theoretical underpinnings for the study and the research hypotheses. The design of this study, its significance to both theory and practice, and its assumptions and limitations were presented. The chapter concluded with a definition of terms used throughout this document. Chapter 2, Review of the Literature, includes a review of the literature pertaining to performance appraisal effectiveness as defined by employee performance appraisal reactions, specifically performance appraisal satisfaction within the social context of a distributed workplace arrangement. The chapter is organized into six sections and concludes with a summary.

Chapter 3, Research Design & Methodology, presents the purpose of the study, the theoretical underpinning, and the research hypotheses. The chapter outlines the design of the study, the population and the sample, the measurement instruments, the control variables, the procedures for data collection and preparation, the procedures for data analysis, and the

examination of reliability and validity. The chapter includes the assumptions and limitations of the study and the ethical considerations. Chapter 3 concludes with a summary.

Chapter 4, Results, presents the results from the analysis of the data collected in support of this study. The chapter begins with a description of how the data were collected and its characteristics, outlines how the data were scrubbed and made ready for analysis, continues with a review of the measures and correlation coefficients, and details the assumption testing and describes how these elements were tested and evaluated. The approaches to testing the hypothesized relationships are presented through a detailed examination of these relationships. Chapter 4 concludes with a summary.

Chapter 5, Discussion, presents a discussion of the findings and conclusions from the study. The chapter discusses the findings in relation to the existing literature based upon the data analysis in Chapter 4. Conclusions and implications for theory are presented, followed by implications for HRD research and then for practice. Limitations are outlined, and the chapter concludes with a number of suggestions for future research.

## **Chapter 2: Review of the Literature**

### **Introduction**

This chapter includes a review of the literature pertaining to performance appraisal effectiveness, specifically the elements that affect or result in performance appraisal satisfaction within the social context of a distributed workplace arrangement. The chapter is organized into six sections. The first section outlines how performance appraisals are a central component of performance management. The second section reviews new directions toward performance appraisal satisfaction as an employee performance appraisal reaction. The third section details how LMX and justice perceptions influence performance appraisal satisfaction. The fourth section explains how social context can influence performance appraisal satisfaction. Social context includes organizational structures such as distributed workplace arrangements. The features of distributed workplace arrangements are described, along with the performance appraisal challenges of distributed workplace arrangements. The fifth section indicates that a research gap exists in the performance appraisal literature. Specifically, performance appraisal satisfaction within a distributed workplace arrangement has not been explored. A summary of the chapter is presented in the sixth section.

To conduct this literature review, the University of Texas at Tyler Robert R. Muntz Library computer system was used for searches in the following databases: EBSCOhost Business Source Complete; Sage Management and Organization; ProQuest Dissertations and Theses; PsycINFO; and ScienceDirect. Through a systematic approach, the following search terms were used singularly, in combination, or in plural forms: dispersed workforce; distributed workforce; leader–member exchange; organizational justice; performance appraisal; performance appraisal system; performance evaluation; performance management; performance management process;



performance rating; performance review; procedural justice; remote employee; remote worker; virtual employee; virtual team; and virtual workforce.

The focus of the core retrieval and review of documents was on published articles pertaining to performance appraisals and performance appraisal satisfaction, in combination with manager–employee relationships, procedural justice, and distributed workplace arrangements. The retrieval included peer-reviewed journals, empirical studies, meta-analyses, literature reviews, books, dissertations, and industry publications.

### **Performance Appraisals: Central Components of Performance Management**

Performance management is a strategic business endeavor (Aguinis et al., 2012; Shahmehri et al., 2014) and is one of the most important functions that HR professionals and managers execute (Aguinis, 2013; Judge & Ferris, 1993; Murphy & Cleveland, 1995). It involves identifying, assessing, measuring, and developing employees' performance and aligning these efforts with the goals of the organization (Aguinis, 2013; DeNisi & Pritchard, 2006). Managers who practice effective performance management have stronger results “compared to those who do not, and have at least 50 percent less employee turnover, 10 to 30 percent higher customer satisfaction ratings and twice the net profits” (Pulakos et al., 2012, p. 1).

Performance management has been described as including a set of unstructured events dispersed throughout the year (Spence & Keeping, 2011), with the goal to improve employee performance (DeNisi & Pritchard, 2006). It is generally considered to be associated with creating a shared vision of the purpose and aims of the organization, helping each individual employee to understand and recognize their part in contributing to them, and in so doing to manage and enhance the employee performance of both individuals and the organization (Fletcher & Williams, 1996, p. 169).

The performance appraisal is a central component of the performance management system and process (Gruman & Saks, 2011). A performance appraisal is a required event in which, for a defined period, an employee's job performance and behaviors are rated or described by a person other than the employee, and the results are kept and used by the organization (Coens & Jenkins, 2002). In theory, the performance appraisal fits within the larger realm of performance management. Thus, by extension, the performance appraisal should also focus on performance improvement (Spence & Keeping, 2011).

Performance appraisals have a greater effect on careers and work lives than any other management process (Grote, 2011) and are one of the most ubiquitous management tools used in organizations (Pichler et al., 2015). They are among the most important HR systems in organizations (Cawley et al., 1998) because they represent critical decisions integral to a variety of HR decisions and outcomes (Judge & Ferris, 1993). These decisions serve a variety of organizational purposes (Jawahar, 2007), such as compensation (e.g., salary increases, bonuses) and job assignment movements (e.g., promotions, transfers, demotions). The performance appraisal also supports employee development by identifying strengths and weaknesses, creating opportunities for performance feedback, and facilitating discussions with managers (Tziner, Joanis, & Murphy, 2002). Consequently, performance appraisals are one of the most commonly studied subjects in management and organizational literature (Arvey & Murphy, 1998; Murphy & Cleveland, 1995).

### **A New Direction Toward Performance Appraisal Satisfaction**

Eighty percent of U.S. organizations use some type of performance appraisal, and of those, 90% are dissatisfied with their practices (Hickman, 2001). *Performance appraisal dissatisfaction*, defined as discontentment or unhappiness with the performance appraisal or

events leading up to or after the performance appraisal session (Grote 2011), exists on many levels. Kondrasuk (2012) found 76 problems with performance appraisals and placed them into four categories: the purpose of the performance appraisal, those involved with the performance appraisal, what is measured, and the system and process of the performance appraisal. In a recent survey, over 50% of employees reported that performance appraisals did not provide an accurate assessment of their work, and nearly 25% said they dreaded performance appraisals (Pulakos et al., 2012). Spence and Keeping (2010) described the performance appraisal as a “daunting and painful experience” (p. 1). T. J. Kline and Sulsky (2009) noted that the rite of conducting performance appraisals triggered dread and apprehension, even among the most seasoned managers. Managers were uncomfortable having to inform employees about their performance (Gordon & Stewart, 2009; Gruman & Saks, 2011), and the performance appraisal session remained the most contentious aspect of the performance management process (Gruman & Saks, 2011). Employees also regarded the performance appraisal with anxiety and dislike (Brown et al., 2010). Many “employees are dissatisfied with the performance feedback they receive, and many managers do all they can to avoid giving accurate performance feedback to their employees” (Farr et al., 2015, p. 201).

Performance appraisal dissatisfaction is not uncommon (Bersin, 2013; Culbert, 2010; Pulakos et al., 2015), and there is no general agreement about a solution to the problem. However, most managers agree that feedback provided to employees during performance appraisal sessions is important for a number of reasons, such as, feedback can encourage an effective way of working, can direct behavior toward a productive action plan, and contributes to learning and development (Farr et al., 2015). Furthermore, managers generally agree that performance appraisal effectiveness (of which performance appraisal satisfaction is an element)

can be facilitated by linking rewards to the level of performance described in the feedback. Thus, managers believe that an important part of a manager's job should be providing accurate and worthwhile performance feedback to their employees (Farr et al., 2015).

HR practioner literature is replete with advice and anecdotal evidence about useful performance appraisal methods (Grote, 2000; Grote, 2011; Hickman, 2001). However, the achievement of effective performance management programs remains an unrealized goal (Levy & Williams, 2004). Thus, some organizations are seeking different ways to make performance management practices more effective and satisfying. They are replacing their practices with others that emphasize more frequent feedback, discussions, observations, and development activities (Buckingham & Goodall, 2015; Javad, 2015).

For example, Google leaders are using formal 360-degree appraisals to evaluate employee performance (Javad, 2015). Netflix leaders removed many of their performance management tasks, including the performance appraisal, and encourage performance discussions between managers and employees as essential duties of their work (Javad, 2015). Leaders at Quicken Loans asked their managers to keep two types of employee performance scorecards: one that shows managers where employees are in relation to their targets and another to track employee performance for coaching opportunities (Javad, 2015). Cisco managers conduct at least three performance check-in discussions a year for employees in lieu of a performance appraisal (Javad, 2015). Two prominent consulting organizations have or will be abandoning performance appraisals altogether. In March 2015, Deloitte redesigned its performance management program and replaced performance appraisals with four questions managers answer concerning employee promotion and potential (Buckingham & Goodall, 2015; Javad, 2015).

Accenture will be eliminating of 90% of performance appraisal activities in 2016 (Javad, 2015; Nanterme, 2015).

These performance appraisal practices and tactics indicate that performance appraisals are moving in a new direction. Managers and employees will be required to communicate more effectively and more frequently than ever before to achieve performance appraisal satisfaction (Buckingham & Goodall, 2015; Javad, 2015).

### **Achieving Performance Appraisal Satisfaction**

Cawley et al. (1998) noted that performance appraisal satisfaction was an employee reaction that is a central element of performance appraisal effectiveness. However, performance appraisal satisfaction has not always been associated with performance appraisal effectiveness. Over the years, researchers have defined performance appraisal effectiveness in a number of ways.

**Models of performance appraisal effectiveness.** Prior to the 1980s, researchers equated performance appraisal effectiveness as the psychometric and instrumentation accuracy of performance appraisal rating scales (Spence & Keeping, 2011). The psychometric model of performance appraisals assumed that ratings did not include manager biases (e.g., halo, horn, and leniency effects; Saal, Downey, & Lahey, 1980). In the 1980s, researchers shifted their focus toward developing a better understanding of how managers form judgments of their employees' performance (Arvey & Murphy, 1998). This new focus opened up fresh research possibilities and theoretical frameworks upon which performance appraisals were investigated. Specifically, Landy and Farr (1980) focused their attention on how managers processed information. Feldman (1981) later introduced social cognition concepts, including how employees processed, stored, and applied information. The next 15 years included an abundance of research on the topics of

information processing and performance appraisals (Arvey & Murphy, 1998). However, some researchers (Ilgen et al., 1993; Spence & Keeping, 2011) believed information processing research was not adequate for understanding the dynamics of performance appraisals and indicated that the information phase of research largely ignored the social and human subtleties of performance appraisals.

In the 1990s, Folger, Konovsky, and Cropanzano (1992) analyzed research on justice and fairness perceptions within a performance management framework and suggested a due-process metaphor. Other researchers addressed the influence of broader and ongoing structural and functional changes occurring in organizations that affected performance appraisals (Arvey & Murphy, 1998), as organizations were becoming leaner, were becoming less centralized, and were moving toward team-based methods of production (Arvey & Murphy, 1998). Other researchers (Cascio, 2000; Fletcher & Williams, 1996) studied the likely effects of these changes on the way performance appraisals were conducted and used. Similarly, Murphy and Cleveland (1995) contributed to the understanding of how rating context and organizational goals shaped the behaviors of managers and employees toward performance appraisals.

Murphy and Cleveland (1995) analyzed performance appraisals as goal-oriented behavior and proposed that if the goals pursued by managers were reviewed more carefully, behaviors that are usually treated as rating errors (e.g., giving superior ratings to most employees) would be seen as adaptive reactions to forces in the rating environment, (i.e., rating context). Later, Arvey and Murphy (1998) indicated that reaction criteria represented a neglected area of research that might be integral in evaluating the success of a performance appraisal because it seemed reasonable to presume that employees' reactions to performance appraisals influence appraisal effectiveness. Similarly, Cascio (2000) noted that performance appraisal effectiveness was more

of a multifaceted construct or an ultimate criterion of effectiveness that could not be directly measured, although it could be assessed via other lesser standards. It was further suggested that performance appraisal effectiveness was composed of rater errors, rating accuracy, and qualitative features such as social context and employee reactions (Cascio, 2000).

In their meta-analysis of performance appraisal literature, Cawley et al. (1998) described performance appraisal effectiveness as the entire appraisal system working as a tool toward assessing employee performance. As performance appraisals evolved, they were no longer considered stand-alone events but rather components of larger performance management systems (Levy & Williams, 2004; Spence & Keeping, 2011). Although historical researchers had focused on performance measurement with rating accuracy as the standard, they began to examine other areas, such as the appraisal context, as a definition of performance appraisal effectiveness (Cawley et al., 1998; Keeping & Levy, 2000; Levy & Williams, 2004).

***Context matters to performance appraisal satisfaction.*** Researchers found that performance appraisals were embedded within complex social, emotional, structural, cultural, cognitive, political, and relationship contexts that needed to be understood to realize the intentions of performance management programs (Ferris, Munyon, Basik, & Buckley, 2008; Levy & Williams, 2004; Murphy & Cleveland, 1995). Context is significant to the organizational sciences because it helps frame phenomena in ways that make them easier to understand, which in turn can be acted upon (Ferris et al., 2008). For example, manager–employee dyadic interactions and performance appraisals take place within a work relationship, and this relationship reflects social, emotional, political, and cognitive processes that help explain decision outcomes (Ferris et al., 2008). It is important to recognize that organizational contexts are changing as organizations change their designs and structures with alterations to job

requirements (Ferris et al., 2008) and dismantle outmoded job boundaries toward more fluid and changing work roles (Cascio, 1995).

Similarly, Levy and Williams (2004) contended that performance appraisals take place in organizational social contexts. They noted that context plays a main role in the effectiveness of performance appraisals and in how employees react to appraisals. They maintained that “identifying, measuring and defining the organizational context” (p. 883) in which performance appraisals take place is vital to understanding the effectiveness of performance appraisals. Levy and Williams indicated that social context is being referred to in the research in many ways: the social-psychological process of performance appraisals (Murphy & Cleveland, 1995), the social context of performance appraisals (Judge & Ferris, 1993), the social setting of performance appraisals (Ilgen et al., 1993), the “games that raters and ratees play” (Levy & Williams, 2004, p. 883), and the due process approach to performance appraisals (Folger & Konovsky, 1989; Folger et al., 1992). Performance appraisals should be studied in a social context (Liao & Rupp, 2005; Levy & Williams, 2004; Pichler, 2009, 2012).

Levy and Williams (2004) categorized the social context of performance appraisals into two groups: distal and proximal. *Distal variables* are those that involve organizational culture, climate, goals, HR strategies, external economic factors, technological changes, and workforce composition. Specifically, distal variables are viewed as contextual influences that affect HR processes and programs, including performance appraisals. Levy and Williams determined that little research had occurred on distal variables, which was understandable considering that performance management is a multidimensional theoretical construct that makes it difficult to study methodically. Additionally, the breadth of the constructs that distal variables involve is problematic to measure and implement in a research setting. They also made it clear that given



the nature of distal variables, the direct effects may be small. Nonetheless, Levy and Williams and others (Ferris et al., 2008) indicated that distal factors represented a neglected area of performance appraisal research. Additionally, given that social context exists and can affect performance appraisal effectiveness, it is a research imperative to explore further (Erdogan, 2002; Murphy & Cleveland, 1995; Pichler, 2009, 2012).

In contrast, social context *proximal variables* are those factors that affect the timing and purpose of performance appraisals (Levy & Williams, 2004). The two types of proximal variables are process and structural. *Process proximal variables* include processes that have a direct impact on how the performance appraisal is conducted (Levy & Williams, 2004). Examples of process proximal variables include the manager–employee relationship, performance expectancies, and task characteristics (Ferris et al., 2008). *Structural proximal variables* deal with the configuration of the performance appraisal itself, including its features, frequency, standards, and legitimacy (Ferris et al., 2008; Levy & Williams, 2004).

The examination of these social context issues is not yet complete, especially given the variety, combinations, and complexity of the possible dimensions (Levy & Williams, 2004). Spence and Keeping (2011) reached the same conclusion when they reported that the research literature lagged behind what practitioners were facing with regard to performance appraisal social context.

***Context involves performance appraisal employee reactions.*** Within the social context literature, employee reactions to performance appraisals are the most critical criteria to researchers and practitioners (Balzer & Sulsky, 1990) because they have been found to predict motivation and performance (Nathan et al., 1991; Pettijohn, Pettijohn, & D’Amico, 2001). As a result of the transition from a measurement-based focus to a social context focus, no area within

the performance appraisal literature has seen as dramatic an increase in research attention since 1990 as employee reactions (Levy & Williams, 2004). Employee performance appraisal reactions are a crucial element in determining the effectiveness of performance management programs (Longenecker & Nykodym, 1996; Roberts, 1992).

Pichler (2012) defined *employee reactions* as “individual-level attitudinal evaluations of and responses to the performance appraisal process” (p. 710). In a meta-analysis of employee reactions to performance appraisals, Pichler (2009, 2012) noted that employee reactions include “perceptions of appraisal accuracy, fairness (overall fairness, as well as perceptions of performance appraisal distributive, interactional, and procedural justice) and utility, satisfaction with the appraisal, and motivation to improve performance” (p. 17).

Pichler et al. (2015) noted that although some performance appraisal models have emphasized the need to include social contextual variables, they have done so by using different constructs and frameworks. Pichler (2009, 2012) leveraged the work by Levy and Williams and by Cawley et al. (1998) to assemble an integrated framework that included the various and critical pieces of social context and due process to guide future performance appraisal research. Pichler (2009, 2012) provided a different way to organize and use social context that included the distal and proximal variables, due process, and the traditional and historical psychometric features of rating instruments under the umbrella of “appraisal context” (Pichler, 2009, p. 4). Taken together, this umbrella of appraisal context employs theories such as social exchange, LMX, and organizational justice (Pichler, 2012). Next, Pichler (2009, 2012) indicated employee reactions were the true measure of performance appraisal effectiveness with organizational justice theory as the bridge between appraisal context and appraisal reactions. According to Pichler (2009, 2012) and Pichler et al. (2015), the employee performance appraisal reactions of

accuracy, fairness, procedural justice, motivation to improve, utility, and satisfaction are the collective measures of performance appraisal effectiveness.

*Performance appraisal satisfaction is an employee reaction.* Of Pichler's (2009, 2012) six employee performance appraisal reactions, the most frequently measured reaction in performance appraisal research has been some form of performance appraisal satisfaction or acceptance (Giles & Mossholder, 1990; Keeping & Levy, 2000; Kuvaas, 2011). *Performance appraisal satisfaction* is the overall "valuation of how satisfied the employee is with the performance appraisal" (Pichler, 2009, p. 7). Performance appraisal satisfaction may be the frequently measured reaction because research has shown that employee satisfaction with the performance appraisal and related performance management processes can affect variables such as productivity, motivation, and organizational commitment (Ilgen, Barnes-Farrell, & McKellin, 1993). Also, performance appraisal satisfaction has been found to lead to job satisfaction and lower employee turnover (Grote, 2011).

Due to the importance of performance appraisal satisfaction as established by its research frequency and outcomes (Giles & Mossholder, 1990; Keeping & Levy, 2000; Kuvaas, 2011), it follows that organizations should strive to achieve high performance appraisal satisfaction among employees. Research should set the path toward this goal. As noted earlier, an examination of the social context issues around performance appraisals has not yet been fully explored, given the variety and complexity of the available social context dimensions that can affect performance appraisal satisfaction (Levy & Williams, 2004; Pichler et al., 2015).

**Leader-member exchange quality.** Performance appraisal satisfaction is comprised of three elements: satisfaction with the rater; satisfaction with the performance appraisal feedback; and satisfaction with the rating (Boswell & Boudreau, 2000). Of these elements, Pooyan and

Eberhardt (1989) noted that the first element was the most critical because it involves the manager–employee relationship. Managers play a critical role because they are the predominant appraiser of employees’ performance and provide performance feedback to their employees. To support this position, Thomas and Bretz (1994) found that managers were the most influential raters of employee performance in Fortune 100 companies. The relationships managers hold with their employees will influence performance appraisal satisfaction (Pichler, 2012; Pichler et al., 2015). Gerstner and Day noted, “The relationship with one’s manager is a lens through which the entire work experience is viewed” (as cited in Day & Miscenko, 2015, p. 10).

In performance appraisal research, LMX theory describes the quality of a manager–employee relationship (Duarte, Goodson, & Klich, 1993; Kacmar et al., 2003; Pichler et al., 2015). LMX has been of long-standing interest to HR and organizational behavioral researchers because of the many perceptions and behaviors it can influence (Graen & Scandura, 1987; Liden, Sparrowe, & Wayne, 1997). For example, it explains how Pichler’s (2009) employee appraisal reaction concepts (accuracy, fairness, procedural justice, utility, and satisfaction) are related to one another.

LMX is a subset of social exchange theory that focuses on emotional support and exchanges between managers and their employees (Blau, 1964; Graen & Scandura, 1987; Liden & Maslyn, 1998) and reciprocity (Adams, 1965). LMX is a dominant management and leadership theory that has evolved over the past 40 years, and it stands out with its emphasis on the potentially distinctive relationship between a manager and an employee (Day & Miscenko, 2015). According to LMX theory, managers interact, respond to, and treat subordinate employees differently depending upon their favored status, and these interactions differ by quality and by employee (Dansereau et al., 1975; Gerstner & Day, 1997; Graen & Uhl-Bien,

1995; Wayne et al., 1997). Day and Miskeno noted that these differentiated manager–employee relationships require social context (e.g., workgroups, organizational setting) to understand fully.

High-quality LMX relationships have increased levels of mutual trust, social support, and employee satisfaction, whereas low-quality relationships are characterized by lower levels of these characteristics (Dansereau et al., 1975; Liden et al., 1997). Researchers (Ilies, Morgeson, & Nahrgang, 2005; Tziner, Shultz, & Fisher, 2008) have shown that these relationships affect employee attitudes and behaviors. Employees offered high-quality LMXs are expected to feel obligated to reciprocate in exchange for the special treatment they receive from their manager (Levy & Williams, 2004). Accordingly, Liden and Graen (1980) revealed that employees who enjoy high-quality LMX relationships (in-groups) typically benefit from more opportunities, emotional support, and cooperative interactions compared to employees who maintain low-quality LMX relationships (out-groups). In-group employees enjoy richer work duties and have manager–employee relationships distinguished by loyalty, open communication, and information sharing (Dienesch & Liden, 1986). Out-group employees are less trusted, are given less meaningful assignments, and receive more formal communication. Their job obligations extend only to their formal duties (Liden & Maslyn, 1998).

Another perquisite for in-group employees is that they receive increased participation in the performance appraisal process (Wexley & Klimoski, 1984). Murphy and Cleveland (1995) noted that LMX quality affects how managers treat employees in the performance appraisal process. This position follows theory and research that suggests employees in high-quality relationships receive more information and are allowed greater upward influence in decisions (Dansereau et al., 1975).

A well-reported consequence of relationship quality is that employees in higher LMX relationships are assigned higher performance ratings than employees in lower LMX relationships (Dunegan, Uhl-Bien, & Duchon, 2002; Kacmar et al., 2003; Wayne & Liden, 1995). Duarte and colleagues (Duarte et al., 1993; Duarte, Goodson, & Klich, 1994) provided support that the relationship between objective measures of performance and manager ratings were moderated by LMX, such that favored employees were rated higher regardless of objective performance levels. A number of reasons have been proposed to explain this relationship. According to LMX theory, employees in higher LMX relationships are privileged and have access to more resources than do employees in lower LMX relationships (Gerstner & Day, 1997; Liden & Graen, 1980). Thus, it is possible that access to these resources permits employees in high LMX relationships to improve their performance beyond the performance of employees who lack access to the resources. Some researchers have identified communication as one such resource. Employees who have opportunities to provide and discuss information are a valuable resource that can be differentially allocated by managers (Fix & Sias, 2006).

Researchers have also found that employees in high-quality relationships are more satisfied with their managers (Liden et al., 1997), and there is a positive correlation between manager satisfaction and performance appraisal satisfaction (Giles & Mossholder, 1990; Nathan et al., 1991). These findings explain why cognitive performance appraisal models sometimes fail. Cognitive models strive to create controlled and neutral environments. Managers and employees have idiosyncrasies and motives that influence ratings and concepts that cognitive performance appraisal researchers do not question (Spence & Keeping, 2011).

**Organizational justice.** Another employee performance appraisal reaction is justice. As outlined by various researchers (Dusterhoff et al., 2014; Kacmar et al., 2003; Levy & Williams,

2004; Pichler, 2009, 2012), fairness and justice perceptions are critical employee appraisal reactions that could determine performance appraisal satisfaction. Turgut and Mert (2014) and others (Cawley et al., 1998) noted that it is in the best interest of organizations to maximize employees' justice perceptions; otherwise, employees will not accept performance appraisal programs. Also, performance appraisal program success is predicated on employees' perceptions of fairness and their reactions to important features of the performance appraisal process (Jawahar, 2007). Studies revealed that employees react more positively to fair performance appraisals (Taylor, Masterson, Renard, & Tracy, 1998), and fairness is required for performance appraisals to have a positive effect on employee performance (Cook & Crossman, 2004; Murphy & Cleveland, 1995). In a survey of Fortune 100 companies, practitioners rated the importance of perceived fairness of performance appraisal systems as high (Thomas & Bretz, 1994).

***Organizational justice theory.*** Supporters of equity theory such as Adams (1965) have indicated that individuals seek to maintain equilibrium between their inputs and outputs in comparison to others. The application and implication of this justice principle in organizational settings is called organizational justice theory (Colquitt et al., 2001; Greenberg, 1990). Performance appraisal fairness addresses the justice perceptions of employees during a performance appraisal session (Giles & Mossholder, 1990), and its concepts align with organizational justice theory (Greenberg, 1993). Organizational justice theory treats justice as a perception or influence of performance appraisal satisfaction (Pichler, 2012).

Forms of organizational justice are categorized as one-, two-, three-, and four-factor models. In one-factor models, major forms of justice (i.e., distributive and procedural) are measured with one scale and are highly correlated with each other (Iqbal, Akbar, & Budhwar, 2014). Greenberg's (1990) empirical research established the two-factor model. Greenberg

determined that distributive justice and procedural justice were two distinct dimensions (Iqbal et al., 2014).

Originally, distributive justice dealt with the fairness of decision and distribution outcomes (Z. S. Byrne & Cropanzano, 2001; Colquitt et al., 2001). For example, rewards are outcomes, and how they are distributed are elements of distributive justice (Jawahar, 2007). Under the umbrella of the two-factor model (McFarlin & Sweeney, 1992), distributive justice was proposed to be related to employee types of outcomes (e.g., job satisfaction) and the evaluation of the outcomes related to fairness (Colquitt et al., 2001).

In the early 1990s, procedural justice was proposed as a separate factor (Z. S. Byrne & Cropanzano, 2001). Therefore, it was constructed and measured differently from distributive justice (McFarlin & Sweeney, 1992). The construct of procedural justice developed over time, and initially it emphasized the significance of procedures, facilitating decision making on outcomes, and the distribution of resources to perceived fairness. Subsequently, structural aspects of procedures were included. For example, consideration was given to aspects such as weight, age, employee voice, employee decision-making contributions, accuracy demonstration, and ethical practices (Greenberg, 1990; Leventhal, 1980).

The three-factor model was established to include interactional fairness (Colquitt, Greenberg, & Zapata-Phelan, 2005). Initially, interpersonal treatment fell in the category of procedural justice. Later, it was established as a distinct dimension (Kass, 2008) called interactional fairness (i.e., justice). The defining requirement was the target of the construct; that is, the target of procedural justice was considered to be the system, and the target of interactional justice was considered to be the agent (Cropanzano, Prehar, & Chen, 2002).



Subsequently, the four-factor model was developed, which maintained that interactional justice should be considered distinct from procedural justice, and was also comprised of two subcomponents: interpersonal and informational justice (Iqbal et al., 2014). Interpersonal justice reflects the perceived fairness of the treatment received by employees from managers and organizational leaders (Colquitt et al., 2009). Informational justice is the perceived fairness of the information provided by managers and leaders during the course of decision making (Colquitt et al., 2009). Colquitt (2001) confirmed the four-factor model's validities, and since, the four-factor model has been the most used in empirical research (Iqbal et al., 2014; Jawahar, 2007).

*Procedural justice theory.* Compared to other justice dimensions, procedural justice is often used in performance management research (Folger & Cropanzano, 1998). Perceptions of procedural justice have a greater effect on management and organizations than perceptions of distributive justice (Korsgaard & Roberson, 1995). Procedural justice has certain structural constraints that limit the range and types of possible outcomes. These types and outcomes make some forms of distributive justice difficult to achieve (Folger & Cropanzano, 1998). Further, performance appraisals typically use more formalized and structured interactions that confound or limit interactional and informational justice (Folger & Cropanzano, 1998).

Procedural justice refers to fairness concepts concerning the approaches, mechanisms, and processes used to determine outcomes (Folger & Cropanzano, 1998). It assumes that fairness perceptions of processes by which decisions are made are linked to reactions to those processes and related decision outcomes (Pichler, 2009, 2012). In the context of a performance appraisal, procedural justice refers to the fairness of procedures by which employee performance is assessed (Erdogan, 2002).

Procedural justice addresses control over the decision-making process (Lind & Tyler, 1988). Leventhal (1980) outlined six conditions of procedural justice that go beyond control. The first condition is *consistency*, which states that procedures should be consistent across time and people. The second condition is *bias suppression*, which refers to the point that a procedure can either intensify the tendency to follow biases and prejudice or safeguard, or at least support, objectivity and neutrality. The third condition is accuracy. Decisions should be of high quality and be made with informed views. Procedures that disregard pertinent information or use inappropriate methods are likely to yield inaccurate and unfair decisions. The fourth condition is *correctability*, and it requires that opportunities exist for the mediation or reversal of decisions. The *representativeness* condition requires decision making to be collaborative, and involved parties are represented in the decision-making process. The sixth condition is the precept of *ethicality*, which requires that behavior be ethical and abide by the norms of a situation or organization. Violations of these conditions led to perceptions of unfairness, even if the actual procedural outcomes were thought to be just and suitable (Umlauf & Dalbert, 2012).

Procedural justice is sometimes described using the due-process metaphor (Folger et al., 1992). This description is due in part to the seminal work by Thibaut and Walker (1975), who indicated that individuals in dispute-resolution situations desire both decision control (i.e., control over the final outcome of the process) and process control (i.e., control over the procedures used to arrive at outcomes). Similarly, procedural justice is perceived when formal rules and procedures are consistent with the principles of due process (e.g., adequate notice, opportunity to appeal) (Folger et al., 1992; Korsgaard, Sapienza, & Schwieger, 2001). Whereas Thibaut and Walker (1975) worked within a legal setting, procedural justice theory has been

effectively applied to a variety of HR systems, primarily in the area of performance management (Pichler, 2009).

Performance appraisal fairness perceptions are critical to HR systems because performance appraisals can be one of the most complicated and litigious HR management practices in organizations (S. E. Kim & Rubianty, 2011). Also, Jawahar (2007) suggested that procedural justice influences performance appraisal satisfaction with performance feedback. For example, Cawley et al. (1998) found that performance appraisal research consistently documented the opportunity to express oneself and one's procedural justice perspectives was positively related to employee performance appraisal reactions.

*Procedural justice and social context.* Performance appraisal researchers have largely neglected the greater social context within which fair and unfair interactions occur. For example, researchers have not considered macro-level social context variables such as organizational structure (Schminke, Ambrose, & Cropanzano, 2000). Schminke et al. (2000) surveyed employees in 11 organizations ( $n = 209$ ) and found that organizational centralization was negatively related to perceptions of procedural fairness, and organizational size was negatively related to interactional fairness. These results indicate that social context components such as organizational structure and design should have a prominent role on research agendas concerning organizational justice and its four factors (Schminke et al., 2000). However, a review of the literature did not surface more recent studies pertaining to macro-level components, such as, organizational structures.

*Procedural justice, LMX, and performance appraisals.* In modeling the justice–LMX relationship, event-based justice perceptions influence LMX. This proposition is consistent with the past research supporting the justice-LMX relationship via a social exchange lens (e.g., Burton

Sablynski, & Sekiguchi, 2008; Colquitt et al., 2009; Masterson et al., 2000). Findings indicate that employees evaluate the fairness of specific events such as performance appraisals (Taylor, Tracy, Renard, Harrison, & Carroll, 1995), pay decisions (Folger & Konovsky, 1989), selection decisions (Gilliland & Hale, 2005), and layoff decisions (Skarlicki, Ellard, & Kelln, 1998). The evaluation can involve all four dimensions of organizational justice: distributive, procedural, informational, and interpersonal (Colquitt et al., 2001).

Pertaining to the performance appraisal session, Dusterhoff et al. (2014) used hierarchical regression analysis in a study with 71 participants within one company and found that LMX and justice perceptions were interrelated. LMX influenced both performance appraisal satisfaction and perceived utility, mediated by employee voice and justice perceptions. In a related study, Pichler et al. (2015) used multilevel modeling with 62 manager–employee dyads and found that LMX was a significant predictor of employee perceptions of procedural justice, performance ratings, and performance appraisal satisfaction. Procedural justice partially mediated the relationship between LMX and performance appraisal satisfaction. These findings demonstrated the importance of organizational procedures “that are bound by the relationship quality with one’s manager” (p. 8). In general, researchers have found that managers and employees respond more favorably to fair performance appraisal systems (e.g., less emotional fatigue, more willingness to accept feedback, more positive reactions toward the manager, more favorable reactions toward the organization, and more satisfaction with the performance appraisal system and the job on the part of both manager and employee) (Brown & Benson, 2003; Dusterhoff et al., 2014; Leung, Su, & Morris, 2001).

## **The Social Context of Distributed Workplace Arrangements**

Social context includes organizational structures such as distributed workplace arrangements. This section describes the contemporary shifts of workplace arrangements toward distributed work. Also, the four features of distributed workplace arrangements are described, along with the performance appraisal challenges of performance feedback richness, frequency, and availability in distributed workplace arrangements. Finally, this section indicates that despite what researchers already know about performance appraisal satisfaction, namely that LMX and justice constructs are embedded within social contextual dynamics, more research is needed. Specifically, more performance appraisal research is needed in the area of organizational structures such as distributed workplace arrangements.

**The changed workplace: A distributed workforce.** Specific to this study and in response to the call by Levy and Williams (2004) for more performance appraisal research associated with social context distal variables such as organizational structures, a need exists to explore how employees in distributed workplace arrangements operate when compared to collocated employees. Collocated employees are “individuals who are physically located close together and can work in face-to-face contexts” (Brewer, 2015, p. 8). A distributed workplace arrangement is an organizational structure within which an employee engages in distributed work (Golden, 2009). Distributed work is referred to as telework, telecommuting, remote work (Golden et al., 2009), geographically dispersed, geographically distributed work (Purvanova, 2014), and virtual work (Golden et al., 2009). With the proliferation of distributed teams, global teams, collaboration through outsourcing, contract work, mergers, telework, hoteling, multiple office facilities, and satellite offices, the meaning of going to work is changing (Rockmann & Pratt, 2015).

Watson-Manheim, Chudoba, and Crowston (2002) wrote that evidence from a variety of sources indicated that although collocated onsite work had been the dominant workplace arrangement, this dominance was lessening. In 2002, approximately 60% of professional employees worked at different geographic locations from their managers or peers (Kanawattanachai & Yoo, 2002). In support of the changing workplace arrangement perspective, a Towers Watson (2012) global study of 32,000 employees in 29 countries found that jobs and activities are being dismantled and organized in new ways, dispersed more widely, and managed across time zones and borders. In the same survey, Towers Watson reported that 47% of the survey participants worked remotely or in some type of flexible workplace arrangement and that, by 2022, the number of employees who telework would grow even more, especially in industries dominated by highly skilled knowledge workers.

According to the U.S. Census Bureau (2012), 13.4 million people worked at least one day at home per week, which represented an increase of over four million people (35%) in the last decade. The 2012 census data revealed that the percentage of U.S. workers who worked at least one day at home increased from seven percent in 1997 to 9.5% in 2010. During the same time period, the population working exclusively from home increased from 4.8% of all workers to 6.6%. The population working both at home and at another location increased from 2.2% to 2.8% of all workers. Further, the percentage of workers who worked the majority of the workweek at home increased from 3.6% to 4.3% of the U.S. population between 2005 and 2010 (U.S. Census Bureau, 2012).

Eighty percent of the workforce uses meetings that involve off-site workers, and organizations indicate that an average of 27% of their employees work virtually (Brewer, 2015). The Society for Human Resource Management (Maurer, 2015) reported similar findings. Remote

work has increased exponentially in the past two decades, and the number of managers who work remotely also rose, perhaps signaling that remote work has become part of the mainstream work culture (Maurer, 2015).

The need for a flexible workforce and opportunities brought about by advancements in technology have allowed for distributed workplace arrangements to multiply in number and degree (Hakonen & Lipponen, 2008; Purvanova, 2014). Technology for managing information and for managing communication has been commonly embraced, which enables organizations and their employees to collaborate from progressively more distant locations. These technological advances have overlapped with employees' needs for a better work–life balance (Harpaz, 2002). Employees believe when their work life needs are met, they will be more productive (Bailey & Kurland, 2002). This growth has also occurred because managers believe that organizations with contented workers perform better (Taris & Schreurs, 2009).

Distributed employees propel organizations' progress (Brewer, 2015). The use of distributed workplace arrangements has allowed organizations to realize cost savings and assemble employees regardless of their geographic locations (Cascio, 2000). Organizations have been able to leverage employees' availability and skills to be more responsive, adaptive, and flexible (Bell & Kozlowski, 2002).

Despite the growth of distributed workplace arrangements, Golden and Veiga (2008) maintained that research investigating virtual work was failing to explain how extensively employees worked and performed in distributed settings. Recent research has only partially addressed Golden and Veiga's claim. In a literature review comparing collocated teams to distributed teams, Purvanova (2014) discovered that despite the vast amount of research on the topic of virtual teams, it tended to lack ecological validity due to its experimental nature. That is,

it generally failed to simulate the contextual conditions under which actual distributed employees work. Similarly, many studies made comparisons within a sample of distributed or collocated employees, but typically did not compare the two sets (MacDuffie, 2007). Although the tasks, objectives, and mission of distributed and collocated employees did not differ (MacDuffie, 2007), the processes they used to achieve their objectives differed because of the constraints they faced (MacDuffie, 2007). Given the pervasiveness and apparent advantages to organizations that use distributed employees, it is important for researchers to understand how the two sets compare.

**Four features of distributed work.** Distributed work has always existed on some level. However, the nature and management of distributed work has changed considerably in the past two decades. Through technology, employees have been able to communicate more effectively and to work with others at a distance. Distributed work is distinguished by four features that make it different from more traditional work (Brewer, 2015).

First, the physical distance involved makes distributed work different from traditional work. There is some degree of physical distance between employees in a distributed workplace arrangement, and face-to-face contact is less. Although the distance needed to qualify as distributed work has been debated (Kraut, Fussell, Brennan, & Siegel, 2002), it appears that any time the workspace is not collocated, an opportunity to collaborate without face-to-face contact exists (Brewer, 2015).

Second, consistent with the literature on telecommuting (Gajendran & Harrison, 2007) and virtual teams (Hertel et al., 2005), distributed work requires that employees are interpersonally connected with other employees. This connection could involve a single person, a



team, or others in an organization. Being a distributed employee means the employee must be distributed from others (Brewer, 2015).

Third, communication technology bridges physical distance. Distributed employees often have several communication options available to enable work in order to address distance challenges and a lack of face-to-face contact. For example, e-mail technology facilitates time-lagged or asynchronous communication. Other technologies such as videoconferencing and instant messaging facilitate real-time or synchronous communication among those at a distance. Additional technologies such as Google Docs, Adobe Connect, and DropBox facilitate collaboration among distributed employees, while corporate networking applications such as virtual private networks allow employees to connect to secure networks even at a distance (Brewer, 2015).

Fourth, distributed work involves reduced supervision. Managers have greater difficulty monitoring and managing distributed employees than they do monitoring and managing collocated employees (Cascio, 2000). Managers have to be more active and flexible in their management of distributed employees via technology. They must replace walking around and checking on everyone with indirect observational activities such as telephone calls, e-mails, reports, and statuses from their distributed employees (Brewer, 2015).

Thus, distributed work is work done “under reduced supervision with others at some physical distance, facilitated by communication technology” (Rockmann & Pratt, 2015, p. 6).

### **Performance Appraisal Challenges in a Distributed Workplace Arrangement**

As previously stated, the performance appraisal literature indicates that managers seem to struggle with performance appraisals (Grote, 2011; Kondrasuk, 2012; Pulakos et al., 2012; Spence & Keeping, 2011). In distributed workplace arrangements, performance management is

by far the biggest challenge for managers (Cascio, 2000), who must conduct performance management activities very well. Managers have to use indirect feedback from information sources and communication technology to identify, assess, measure, and develop distributed employees' performance (Cascio, 2000).

In a related study, Kurland and Cooper (2002) revealed that distributed managers (that is, managers who worked virtually) processed employee performance information differently depending upon the source. They trusted the most direct source and thus applied it most toward employee performance improvement. In other studies, managers interacted more often with employees electronically and trusted secondhand sources of information more to make their performance assessments (Kurland & Cooper, 2002). Secondhand information included feedback from coworkers, customers, and others who observed the employee in the manager's absence (Murphy & Cleveland, 1995). Taken together, these studies indicate that distributed managers rely most on performance information they observed or heard directly, rather than on information received virtually. The firsthand and richer nature of information obtained in direct observations means that this information has more influence than information obtained virtually (Golden et al., 2009). Further, overall performance was biased in the direction of performance information that was observed directly. These findings indicate that performance ratings conducted by distributed managers were different from more traditional approaches by collocated managers (Golden et al., 2009).

Additionally, online communication is more complex than face-to-face communication (Brewer, 2015). When giving performance criticism, managers often received no reply or negative responses from distributed employees (Brewer, 2015). Also, managers noted that

necessary performance changes often took longer, and performance criticism was easier to give face-to-face (Brewer, 2015).

This difficulty may be due to the fact that the effectiveness of performance feedback and communication is constrained by contextual or situational factors (Levy & Thompson, 2015). These factors are present in every work environment (Levy & Thompson, 2015), and especially in distributed workplace arrangements (Cascio, 2000). The collection of these factors is referred to as the feedback environment (Steelman et al., 2004). A *feedback environment* is “the contextual aspects of the day-to-day supervisor–subordinate and coworker–coworker feedback process” (Steelman et al., p. 166). Without considering the influence of contextual factors, it is difficult to understand the feedback process or improve performance management programs (London & Smither, 2002). A strong positive feedback environment is one where employees steadily receive feedback and are encouraged to ask for and use feedback to improve job performance (Levy & Thompson, 2015).

Employees working in distributed workplace arrangements have found problems more challenging to identify and resolve, communication signals reduced, and trust longer to develop (Brewer, 2015). They spend more time in asynchronous than in synchronous communication (Brewer, 2015). Thus, distributed employees may have greater difficulty demonstrating performance progress and results to their managers (Cascio, 2000). These challenges were demonstrated in an employee’s statement from a qualitative study on the unintended consequences of distributed work (Rockmann & Pratt, 2015). The employee reminisced about the productive relationship he had had with his manager before choosing to work primarily offsite. The employee noted that whenever his manager had needed something, the employee

“could just toss it over the wall” (Rockmann & Pratt, 2015, p. 12). This in turn provided the employee with more visibility.

In the example above, the feedback environment for the distributed employee has changed and it was easier for the employee to interact with his manager when the employee was collocated. Research pertaining to feedback has two important implications for organizations. First, the employee and manager create distinct feedback environments. The feedback environment is the setting for performance feedback, and the environment is a contextual variable. Second, contextual variables have a significant influence on employees’ task performance. Instead of merely providing feedback, organizational leaders should consider its quality (i.e., richness), frequency, and availability in order to improve employee performance (Levy & Thompson, 2015).

**Lack of media richness.** Gordon and Stewart (2009) contended that performance appraisal issues should be addressed using applied communication (versus management) research. They noted that some performance appraisal problems are rooted in procedures that interfere with effective communication. Neglecting the communication perspective of performance appraisals is unfortunate for three reasons. First, despite the various and new approaches to performance appraisals, the performance appraisal session is still the most important component of a performance management program (Grote, 2011). Second, focusing on communication offers a broader performance appraisal perspective: how performance information is given and perceived, performance terms and procedures, and the interactional setting that affects the meaning of the feedback. Third, a focus on communication has been demonstrated to improve other HR programs (e.g., assessment centers, coaching) (Gordon & Stewart, 2009).

To explore further how performance feedback is different for distributed employees, media richness, a communications construct, offers an explanation. According to *media richness theory*, also known as information richness theory (Golden et al., 2009), face-to-face interactions are the richest form of information because they contain a complete variety of informational cues (e.g., voice tone, nonverbal behaviors, and contextual background indicators) (Daft & Lengel, 1986). Golden et al. (2009) stated that the type of communication medium most appropriate for a task depends on the level of uncertainty and the task's ambiguity. The task's ambiguity or equivocality can involve the amount of information to be exchanged or understood and how dependent the decision makers are on one another (Daft & Lengel, 1986, p. 560). Daft and Lengel (1986) provided a list of communication approaches in order of decreasing richness: face-to-face, telephone, personal documents (e.g., letters, memos), impersonal written documents, and numeric documents. Specific elements make communication rich, including the medium's capacity for immediate feedback, the number of cues and modalities used, personalization, and the variety of language used (Daft & Lengel, 1986).

Golden et al. (2009) provided evidence relating to the sensibility of using face-to-face communication during a performance appraisal and confirmed that the information managers receive about and from their distributed employees is apt to be less rich and to contain fewer informational cues than the information they receive about and from their collocated employees (Golden et al., 2009). Similarly, information received via telephone, e-mail, or reports from other sources does not contain the same amount or degree of information. Thus, the lack of richness may instill less confidence in the information received. As a result and as noted prior, when managers have access to both direct and virtual information, they are likely to discount

information acquired virtually (Golden et al., 2009), which suggests that distributed employees are at a disadvantage at conveying richer information than their collocated counterparts.

In a study involving performance appraisals of peers, results indicated that the communication medium matters. Performance feedback was perceived as more negative in an online environment than in face-to-face or paper-form approaches (Kurtzberg, Naquin, & Belkin, 2006). Kurtzberg et al. (2006) noted, “The exact same message, when delivered via e-mail, was treated with more negativity than when delivered in any other way, written or spoken” (p. 14). These findings are consistent with media richness theory. It follows that the circumstances typically associated with performance appraisals need a rich communication medium as the most appropriate way to offer performance feedback. This is in part because performance appraisals can be multifaceted, ambiguous, and emotionally charged (Russ, Daft, & Lengel, 1990). These results indicate that face-to-face performance feedback will result in a more effective exchange of information (Gordon & Stewart, 2009).

Communication mediums also influence justice perceptions. Distributed employees mainly interact with their managers via information and communication enabled by technology, so they must rely on a limited number of procedural justice cues (Hakonen & Lipponen, 2008). In a simulated study ( $n = 447$  students), Westerman, Heuett, Reno, and Curry (2014) revealed that participants who receive performance feedback via telephone perceived higher levels of justice than those receiving feedback via text messages. In keeping with media richness theory (Daft & Lengel, 1986), the richer communication medium (the telephone call) was seen as more fitting for delivering potentially equivocal messages such as performance feedback when compared with text messaging. Thus, the telephone call was seen as more just (Westerman et al., 2014).

Some researchers maintain that previous studies concerning distributed employees have largely ignored the role of procedural justice (Hakonen & Lipponen, 2008). Perceived justice is especially important when employees experience high levels of uncertainty, and because uncertainty and ambiguity are typical of distributed employees, these employees look for information about procedural justice to reduce their uncertainty (Hakonen & Lipponen, 2008).

**Lack of feedback (communication) frequency.** As noted prior, performance feedback is an important element in improving employee performance (Cascio, 2000). Levy and Williams (2004) referred to the feedback environment as a social contextual variable that is an integral part of a broader performance management process. They contended that factors such as perceived source credibility, frequency, and quality feedback affected employees' attitudes and behaviors. Kuvaas (2011) confirmed that perceived frequency of day-to-day work-related feedback outside of the formal performance appraisal moderated the relationship between perceived helpfulness of the performance appraisal and work performance.

These studies indicate that feedback frequency matters. Kacmar et al. (2003) found that employees who communicated with their managers more frequently and were in high-quality LMX relationships received the highest performance ratings. In other research, engaging in social communication influenced trust. The key difference between the process of creating trust across a distance and in a face-to-face setting was the rate (i.e., frequency) of the social information exchange rather than the amount of information exchanged (Brewer, 2015).

Similarly, Levy and Thompson (2015) maintained that daily communication (i.e., feedback) is immensely valuable to both the employee and the organization. If the performance management process is implemented effectively, the accumulation of daily feedback over time should be strongly associated to the summary information provided to the employee as part of

the performance appraisal discussion (Levy & Thompson, 2015). Also, there is evidence that employees value and want performance feedback (Farr et al., 2015). Many employees state that they do not receive enough feedback related to their managers' assessments or expectations about their performance, which indicates a need for more information about whether employees are doing the tasks that are expected, whether their performance is at a satisfactory level, and how they can improve (Farr et al., 2015).

Managers are the primary source of performance feedback for employees, especially for those in high-quality LMX relationships (Andrews & Kacmar, 2001). The more frequently an employee in a high-quality LMX relationship communicates with his or her manager, the better the manager feels about the relationship (Kacmar et al., 2003). Because communication in low-quality LMX relationships can be confrontational and negative, it makes sense that more frequent interactions of these kinds will worsen problems in the relationship. This logic suggests that communication frequency amplifies a low- or high-quality LMX relationship (Kacmar et al., 2003). Due to distance and technology, how communication frequency operates in relation to LMX quality may be different in a distributed workplace arrangement compared to a collocated arrangement (Golden et al., 2009).

**Extent of the distributed workplace arrangement.** The extent of work that an employee performs away from his or her office site and/or manager can also be a challenge to satisfaction outcomes (e.g., performance appraisal satisfaction). Allen, Golden, and Shockley (2015) stated that the extent of telecommuting mattered and that there is “an impressive array of evidence that the extent to which an individual works away from a central office makes a difference in determining outcomes” (p. 60). They also stated that although distributed workplace arrangements such as telecommuting have often been studied as a two distinct



variables (i.e., those who are in virtual arrangement and those who are not), this approach has not realistically represented contemporary distributed workplace arrangements. For example, in a study of 375 virtual employees, Golden (2009) determined that the extent of virtual work moderated the relationship between LMX, organizational commitment, job satisfaction, and performance. It was found that the extent to which a virtual workplace arrangement was used, the LMX quality was affected.

### **Gaps That Require Further Research**

This fifth section of the literature review indicates that a research gap exists in the performance appraisal literature. Leaders in many U.S. organizations do not believe their performance management programs are effective (Buckingham & Goodall, 2015; Cunningham, 2015). In the past, effectiveness was typically defined as accurate performance appraisal ratings (Spence & Keeping, 2011). However, in the last few years, this definition has expanded to include employee reactions (Levy & Williams, 2004; Pichler, 2012). These employee reactions included elements of accuracy, fairness, motivation to improve, utility, and performance appraisal satisfaction (Keeping & Levy, 2000; Levy & Williams, 2004; Pichler, 2012). Although researchers have confirmed how some constructs such as LMX quality and justice perceptions influence performance appraisal satisfaction, they have yet to investigate the various social contexts that could affect performance appraisal satisfaction (Schminke et al., 2000).

A variety of social context variables are at play at any given time, and organizational structures such as distributed workplace arrangements are one of these variables (Levy & Williams, 2004; Pichler, 2012). Media richness (Daft & Lengel, 1986) and feedback frequency (Kacmar et al., 2003) seem to be challenges in distributed workplace arrangements. Media richness theory has confirmed that communication modalities that are not face-to-face provide

less desirable outcomes when tasks are equivocal and interdependent decisions need to be made. This perspective puts performance appraisal satisfaction at risk for distributed employees. Lean managerial observations could influence performance feedback quality and thus employees' performance appraisal ratings, both of which could reduce employees' performance appraisal satisfaction. Similarly, these lean observations could negatively affect downstream HR-related employee decisions (e.g., promotions, compensation, terminations, training). Feedback frequency also affects how employees perceive managerial fairness (Kacmar et al., 2003).

Given the proliferation of distributed workplace arrangements (U.S. Census Bureau, 2012) and the increased attention to organizations shifting their performance appraisal practices to emphasize feedback, discussions, observations, and development (Buckingham & Goodall, 2015; Javad, 2015), the extent to which distributed employees work away from central offices and their managers is an important dynamic to consider in performance management research efforts (Bailey & Kurland, 2002).

**The targeted gap.** As more organizations increase the use of performance feedback tactics as proxies for performance appraisals, researchers have yet to determine to what extent these efforts will be successful in the contemporary reality of distributed workplace arrangements. Thus, this study will address the social context of distributed workplace arrangements and the related communication implications of media richness and communication frequency in relation to LMX, procedural justice, and performance appraisal satisfaction.

## **Summary of Chapter 2**

The preceding literature review categorized the various research streams that comprise the multidimensional context of performance appraisals, specifically their social context and related employee reactions. The chapter included a review of the literature pertaining to

performance appraisal effectiveness and the elements that affect or result in performance appraisal satisfaction within the social context of a distributed workplace arrangement. The first section indicated how performance appraisals are a central component of performance management. The second section reviewed new directions toward performance appraisal effectiveness and satisfaction with an emphasis on employee reactions. The third section detailed how LMX and justice perceptions influence performance appraisal satisfaction, followed by the fourth section that explained how social context can influence performance appraisal satisfaction. The fifth section indicated that a research gap exists in the performance appraisal literature, as performance appraisal satisfaction within a distributed workplace arrangement has not been explored. Further, while the literature reflects a substantial amount of research on performance appraisals and performance appraisal satisfaction (Arvey & Murphy, 1998; Pichler, 2009, 2012) in relationship to manager–employee relationship quality and procedural justice, there is limited research within the context of a distributed workplace arrangement. Therefore, this study included an examination into a collection of variables: performance appraisal satisfaction, LMX, procedural justice, media richness and communication frequency.

## **Chapter 3: Research Design and Methodology**

### **Introduction**

This chapter outlines the research design and the methodology of the study. It contains 13 sections. The first section explains the purpose of the main study. The next section summarizes the two pilot studies conducted prior to, and in support of, the main study. The remaining sections pertain to the main study. The third section includes the study's theoretical foundation and hypotheses. The fourth section details the design of the study, followed by the fifth section that explains the population and sample. The sixth section outlines the control variables. The seventh section details the study's data collection procedures, followed by the next section that describes the data preparation steps. The data analysis procedures are explained in the ninth section. Steps to check for reliability and validity are discussed in the 10th section. Assumptions and limitations are detailed in the 11th section. The 12th section contains the ethical considerations, and the chapter ends with a summary.

### **Purpose of the Main Study**

This study examined the social context of distributed workplace arrangements and the associated communication implications of media richness and communication frequency in relation to LMX, procedural justice, and performance appraisal satisfaction. These relationships were analyzed from the employee's perspective.

### **Two Pilot Studies**

Two pilot studies were conducted prior to and in support of the main study. They were conducted to examine the relationships between LMX, procedural justice, and performance appraisal satisfaction prior to adding the social contextual variable of distributed workplace arrangement. See Figure 2 for the Pilot Study 1 and Pilot Study 2 conceptual model.

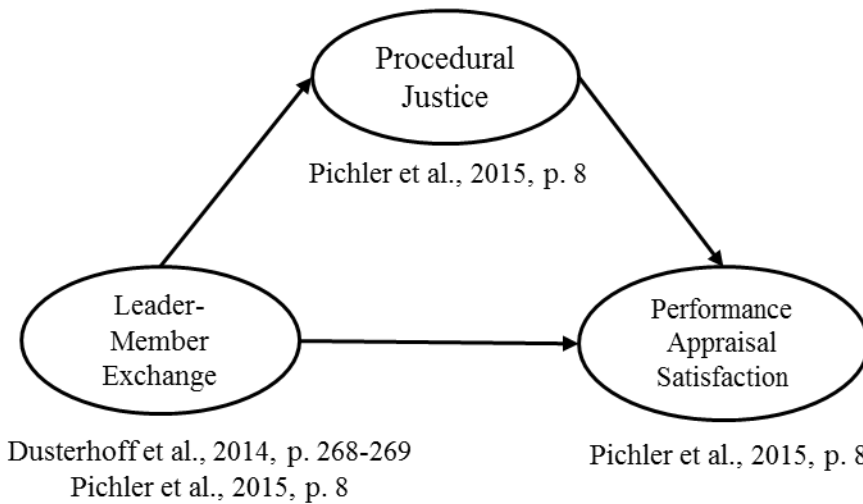

Figure 2. Pilot Study 1 and 2 conceptual model of the mediating effect of procedural justice on LMX and performance appraisal satisfaction.

**Overview of Pilot Study 1.** The purpose of the Pilot Study 1 was to examine how procedural justice may influence the sign or strength of the relationship between LMX and performance appraisal satisfaction. These relationships were analyzed from the employee’s perspective. The hypotheses were as follows:

- H<sub>1</sub>: *LMX is positively related to performance appraisal satisfaction.*
- H<sub>2</sub>: *LMX is positively related to procedural justice.*
- H<sub>3</sub>: *Procedural justice is positively related to performance appraisal satisfaction.*
- H<sub>4</sub>: *Procedural justice mediates the relationship between LMX and performance appraisal satisfaction.*

Control variables of age, time in position, and performance rating were used based upon past performance appraisal satisfaction research by Dusterhoff et al. (2014) and techniques recommended by Carlson and Wu (2011).

**Study sample.** Participants for this study were assembled using MTurk as the data collection method because MTurk has been shown to contain the major elements required to

conduct research (Buhrmester, Kwang, & Gosling, 2011; Johnson & Borden, 2012). MTurk is an Internet-based platform that provides an online and diverse participant pool (Buhrmester et al., 2011), tools for survey and experiment creation, and a method of rapid and inexpensive data collection. The survey solicited full-time working employees at or over the age of 18 working in the United States for U.S.-based companies. These qualifications were desired so that participants would most likely have a manager and have experienced a performance appraisal. The total number of respondents was 387, and after culling the responses for complete replies, the resulting sample size was 284 (73%). Of the resulting sample, the average age was between 22 and 30 years ( $M = 2.73$ ) and the average time in position was between 3 and 5 years ( $M = 2.15$ ). The average rating of the participants' last performance appraisal was 3.93, which denoted a skewness toward *exceeds expectations–good* on a 5-point scale.

**Measures.** This study used previously validated measures. The measures were chosen based on their measurement properties and their use in related research.

*Performance appraisal satisfaction.* This construct was measured using four items on a 5-point scale (Dusterhoff et al., 2014). The Cronbach alpha coefficient was  $\alpha = .859$ .

*Leader–member exchange.* LMX was measured using seven items on a 5-point scale (Graen & Uhl-Bien, 1995). The Cronbach alpha coefficient was  $\alpha = .922$ .

*Procedural justice.* This construct was measured using seven items on a 5-point scale (Colquitt et al., 2005). The Cronbach alpha coefficient was  $\alpha = .909$ .

Respondents were asked to report their most recent performance appraisal rating. These ratings used a 5-point scale of 1 = *unsatisfactory–very poor*, 2 = *does not meet expectations–poor*, 3 = *meets expectations–good*, 4 = *above expectations–good*, 5 = *exceed expectations–excellent*.

**Descriptives and correlations.** Table 1 presents the means, standard deviations, and correlations for the Pilot Study 1 variables. For all measures, values were above the mean, which indicated that respondents were in general more positive than not. Table 1 shows the correlations between performance appraisal satisfaction, LMX, and procedural justice were positive and significant ( $p = .01$ ), with correlations between performance appraisal satisfaction ranging from .641 for LMX and .760 for procedural justice. These correlations were positive and significant, as would be expected from previous research (Dusterhoff et al., 2014; Graen & Uhl-Bien, 1995).

Table 1

*Means, Standard Deviations, and Correlations*

Variable	<i>M</i>	<i>SD</i>	1	2	3	4	5	6
1. Age	2.73	.998						
2. Time in position	2.15	.974	.471					
3. Last performance rating	3.93	.887	-.022	.037				
4. Performance appraisal satisfaction	3.77	.801	-.099	.021	.530**	.859		
5. Leader–member exchange	3.59	.827	-.025	.043	.492**	.641**	.922	
6. Procedural justice	3.41	.859	-.025	.063	.597**	.760**	.766**	.909

*Note.*  $n = 284$ . The reliabilities (alpha coefficients) are reported in the diagonal pattern in the table (numbers in italics).

\*\* $p = .01$ .

**Assumptions testing.** The following assumptions were tested prior to performing the hierarchical regression analysis: reliability of the scales, linearity of the relationships, independence of residuals for dependent variable, homoscedasticity of the errors, and normality (error of distribution) of dependent variable. The assumptions were supported.

**Analysis and results.** Following similar studies (Dusterhoff et al., 2014; Graen & Uhl-Bien, 1995), the hypothesized relationships were tested using multiple regression because two predictor variables were used. SPSS statistical software Version 22 was used to conduct the analysis. The first hypothesis ( $H_1$ ) was designed to test the presence of a positive relationship

between LMX and performance satisfaction. This hypothesis was fully supported ( $\beta = .641, p < 0.001$ ) with  $R^2 = 41\%$ , which indicated that performance appraisal satisfaction was a positive function of LMX. Table 2 summarizes the results of this regression analysis.

Table 2

*Summary of Regression Analysis for LMX as a Predictor for Performance Appraisal Satisfaction*

Predictor	<i>B</i>	<i>SE</i>	$\beta$
Leader–member exchange	.621	.044	.641***
$R^2$			.411

\*\*\* $p < .001$ .

The second hypothesis ( $H_2$ ) aimed to test the presence of a positive relationship between LMX and procedural justice, as measured by LMX and procedural justice. This hypothesis was fully supported ( $\beta = .766, p < .001$ ) with  $R^2 = 59\%$ , which supported the hypothesis that the employee–manager relationship was a positive function of procedural justice. Table 3 summarizes the results of this regression analysis.

Table 3

*Summary of Regression Analysis for LMX as a Predictor for Procedural Justice*

Predictor	<i>B</i>	<i>SE</i>	$\beta$
Leader–member exchange	.796	.040	.766**
$R^2$			.587

\*\*\* $p < .001$ .

The third hypothesis ( $H_3$ ) tested the presence of a positive relationship between procedural justice and performance appraisal satisfaction. This hypothesis was also fully supported ( $\beta = .760, p < .001$ ) with  $R^2 = 76\%$ , which indicated that performance appraisal satisfaction was a positive function of procedural justice. Table 4 summarizes the results of this regression analysis.

Table 4



*Summary of Regression Analysis for Procedural Justice as a Predictor for Performance Appraisal Satisfaction*

Predictor	<i>B</i>	<i>SE</i>	$\beta$
Procedural justice	.760	.036	.760**
$R^2$			.760

\*\*\* $p < .001$ .

*Four-step mediation testing.* The last hypothesis (H<sub>4</sub>) examined whether the mediator, procedural justice, accounted for the increase in performance appraisal satisfaction when controlling for LMX. A mediation analysis was conducted, and during the analysis, the control variables (age, time in position, and performance appraisal rating) were entered in Step 1 to determine if they reflected any impurities in the dependent and independent variables. This technique ensures that the impurities are removed and the estimation of independent and dependent relationships is made more relevant (Carlson & Wu, 2011). Subsequently, when controlling for age, time in position, and performance appraisal rating, the analysis yielded impotent control variables ( $p = 0.00$ ), which meant the control variables overcontrolled the analysis. To avoid Type I error, the control variables were excluded from further modeling and analysis (Neergaard & Ulhøi, 2007). Adhering to Carlson and Wu's (2011) and Becker's (2005) recommendations for improved research practices pertaining to control variables, representations of the impact of the control variables are in Table 5.

Subsequently, a mediation test was conducted without the control variables. Significant associations were found for performance appraisal satisfaction and LMX ( $\beta = .641, p < .01$ ), procedural justice and LMX ( $\beta = .766, p < .01$ ), and performance appraisal satisfaction and procedural justice ( $\beta = .017, p < .05$ ). Having satisfied the three steps, the fourth step of the mediation test revealed that the relationship between LMX and performance appraisal satisfaction was nonsignificant ( $\beta = .650, p < .001$ ) in the presence of procedural justice, which

suggested that procedural justice fully mediated the relationship between LMX and performance appraisal satisfaction. The results of the mediation tests are in Table 6.

Table 5

*Testing for Mediator Effects on Performance Appraisal Satisfaction Using Hierarchical Regression Using Control Variables*

Testing steps in mediation model	<i>B</i>	<i>SE</i>	$\beta$
Step 1 Outcome: Performance appraisal satisfaction Predictor: Leader–member exchange	.483	.048	.499**
Step 2 Outcome: Procedural justice Predictor: Leader–member exchange	.646	.042	.622**
Steps 3 and 4 Outcome: Performance appraisal satisfaction Mediator: Procedural justice Predictor: Leader–member exchange	.548	.060	.589**
	.128	.057	.133**

\*\* $p < .01$ .

Table 6

*Testing for Mediator Effects on Performance Appraisal Satisfaction Using Hierarchical Regression Without Control Variables*

Testing steps in mediation model	<i>B</i>	<i>SE</i>	$\beta$
Step 1 Outcome: Performance appraisal satisfaction Predictor: Leader–member exchange	.621	.044	.641**
Step 2 Outcome: Procedural justice Predictor: Leader–member exchange	.796	.040	.766**
Steps 3 and 4 Outcome: Performance appraisal satisfaction Mediator: Procedural justice Predictor: Leader–member exchange	.138	.056	.017*
	.606	.056	.650**

\* $p < .05$ . \*\* $p < .01$ .

**Discussion.** Procedural justice seemingly determines an employee’s level of performance appraisal satisfaction, regardless of the relationship an employee has with his or her manager.

This relationship is important for managers and HRD practitioners to understand. Practitioners

need to apply fair and transparent policies and procedures within a performance management program or employees will not buy into the program (Panggabean, 2001; Wittmer et al., 2010).

Some HRD practitioners stress one performance management program element over another due to organizational emphasis or practitioner expertise. This research showed HRD practitioners where to start by focusing on the most important component of a performance management program, the performance appraisal, and key contributing variables such as procedural justice and LMX so that performance appraisals can be more satisfying to employees.

**Overview of Pilot Study 2.** The Pilot Study 2 had the same purpose, hypotheses, measures, and population as Pilot Study 1. However, instead of applying a regression analysis approach, it used structural equation modeling to test the conceptual model.

*Analyses and results.* Using Schumacker and Lomax's (2010) guidance, the fit of the data was analyzed using a measurement model prior to testing the theoretical and alternative model. In analyzing the measurement model, all factors were compared to one another; that is, a three-factor correlated model was used. Then, a check for common method variance was completed using Harman's single-factor test. The analysis was completed using IBM SPSS Amos 22.

Furthermore, two structural models were tested. The first was the theoretical model, that is, the full mediation model. This model contained a path from LMX to procedural justice to performance appraisal satisfaction. A second model was tested, and it was a partially mediated model with two paths: (a) LMX to procedural justice to performance appraisal satisfaction and (b) LMX to performance appraisal satisfaction.

The results of the commonly used fit indices as recommended by Schumacker and Lomax (2010) indicated that the three-factor correlated model fit the data better than the single-

factor model. See Table 7. With three degrees of freedom between the two models, a calculation of the delta chi-square yielded a value ( $\Delta\chi^2 = 367.227$ ) with a probability of less than .001 ( $p < .001$ ); thus, it was not significant. This badness-to-fit situation suggested that the two models were similar. A review of the comparative fit index (CFI) values for the two models indicated that the three-factor model at a CFI value above .9 fit the data better (Hu & Bentler, 1999).

Table 7

*Fit Indices for Measurement Models*

Model	$\chi^2$	df	Root-mean-square error of approximation	Standardized root-mean-square residual	Comparative fit index
Three-factor correlated	479.526	149	.089	.0471	.915
Single factor	846.753	152	.127	.0675	.822

The root-mean-square error of approximation for the three-factor model was closer to the recommended range of .05 to .08 (Schumacker & Lomax, 2010). Also, in a review of the standardized root-mean-square residual, the three-factor model was the better fit because the results were less than .05 (Schumacker & Lomax, 2010).

The standardized regression weights in Figure 3 suggested the measurement model was acceptable.

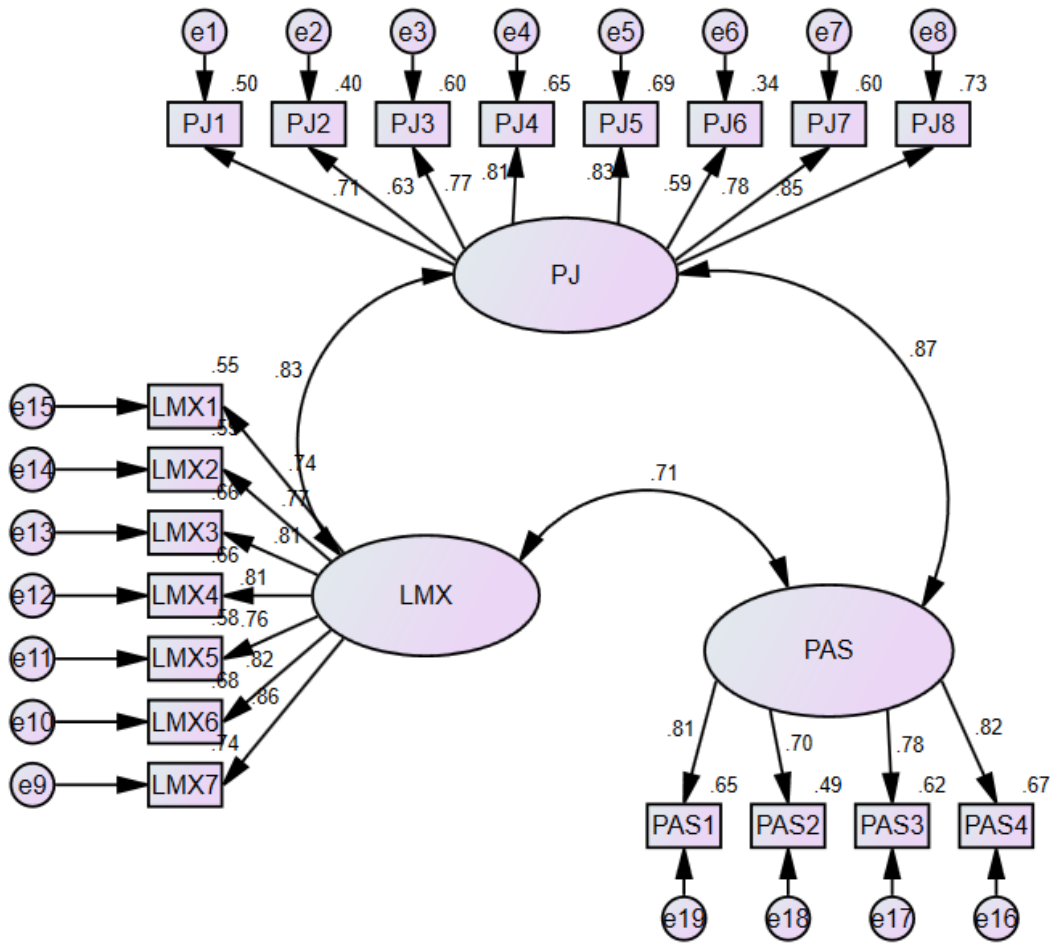

Figure 3. Pilot Study 2 measurement model.

The data further indicated that all the factor loadings were above the .5 minimum, which revealed all values within the recommended range of .7 to .95 (Bagozzi & Yi, 1988). The structure coefficients (compare Graham, Guthrie, & Thompson, 2003) in Table 8 revealed that each of the manifest variables correlated most highly with its appropriate factor. A review of the individual item loading indicated that two items (PJ2 and PJ6) were lower than the factor loading guidance of  $< .7$  (R. B. Kline, 2005).

Table 8

*Pattern and Structure Coefficients for Three-Factor Correlated Model*

Construct variable	Procedural justice		Leader–member exchange		Performance appraisal satisfaction	
	Pattern	Structure	Pattern	Structure	Pattern	Structure
Procedural justice						
PJ1	.710	.710				
PJ2	.634	.634				
PJ3	.774	.774				
PJ4	.808	.808				
PJ5	.832	.832				
PJ6	.586	.586				
PJ7	.777	.777				
PJ8	.853	.853				
Leader–member exchange						
LMX1		.615	.738	.738		.523
LMX2		.641	.770	.770		.545
LMX3		.678	.814	.814		.576
LMX4		.679	.815	.815		.577
LMX5		.635	.762	.762		.540
LMX6		.685	.825	.825		.584
LMX7		.718	.863	.863		.611
Performance appraisal satisfaction						
PAS1		.707		.573	.809	.809
PAS2		.610		.495	.698	.698
PAS3		.686		.556	.785	.785
PAS4		.714		.579	.817	.817

Table 9 shows that the composite reliability ranged from .860 to .925 and the average variance extracted (AVE) ranged from .566 to .639, both of which were above their minimum AVE thresholds. However, most of the correlations between the factors were higher than the square root of the AVE for each individual factor, which indicated a lack of discriminant validity. The factor correlations in Table 9 confirm the four hypotheses, namely that positive relationships existed between LMX and performance appraisal satisfaction, procedural justice and performance appraisal satisfaction, LMX and procedural justice, and procedural justice positively mediated LMX and performance appraisal satisfaction.

Table 9

*Implied Correlations, Average Variance Extracted, and Composite Reliability*

Variable	1	2	3
1. Procedural justice	.752		
2. Leader–member exchange	.833	.799	
3. Performance appraisal satisfaction	.874	.708	.779
Composite reliability	.911	.925	.860
Average variance extracted	.566	.639	.606

*Note.* Square root of average variance extracted along the diagonal.

An assessment of the structural models revealed that Model 1, the fully mediated model (LMX to procedural justice to performance appraisal satisfaction), had the best fit. See Figure 4. With one degree of freedom between the two models, a calculation of the delta chi-square yielded a value ( $\Delta\chi^2 = .516$ ) of less than 1 and a probability of less than .001 ( $p < .001$ ) and thus was not statistically significant. Other fit indices for the two models (i.e.,  $R^2$ , root-mean-square error of approximation, CFI, and standardized root-mean-square residual) shown in Table 8 were very similar in value and within recommended thresholds. Lastly, the parameter estimates for Model 1 were positive, within range, and statistically significantly different than zero.

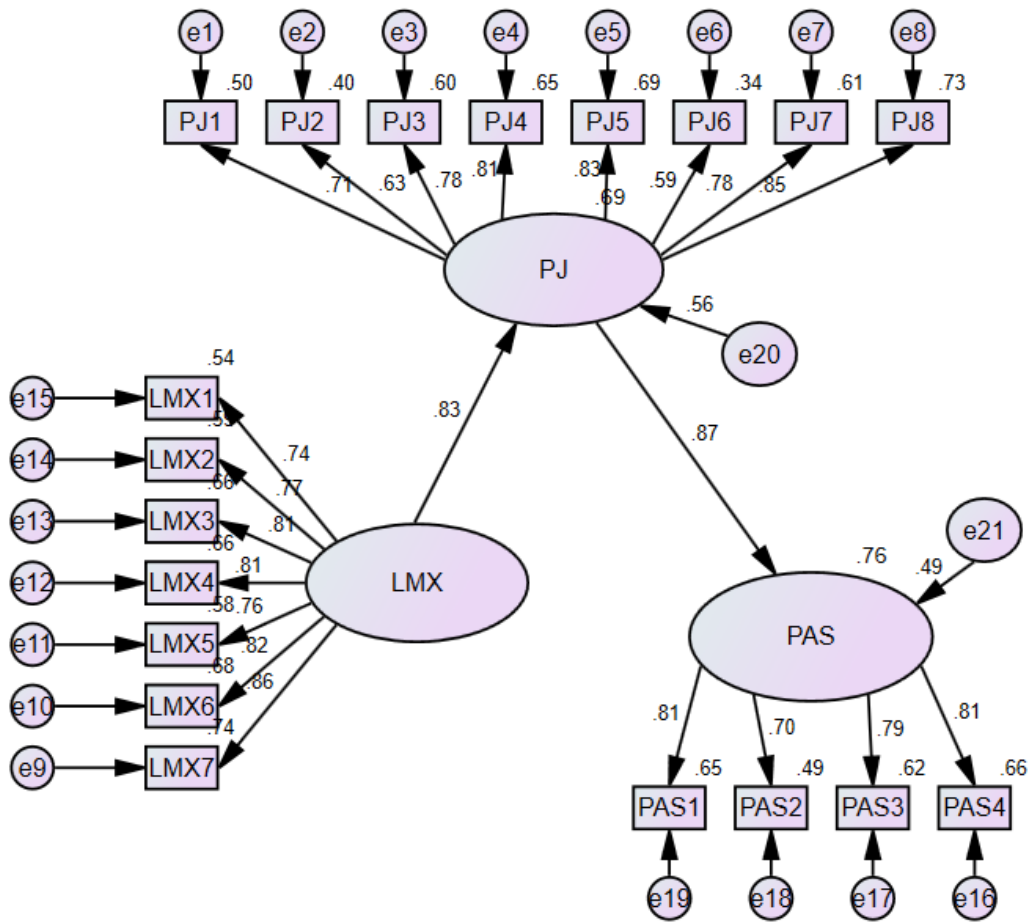

Figure 4. Pilot 2 study measurement model with estimates.

Last, to improve the model fit, three more models were tested when the two previously mentioned low-loading items (PJ2 and PJ6) were removed one at a time and then together. See Tables 10 and 11. The analysis revealed that Model 5, with both items removed, increased the factor loading values but not substantively. Also, with 33 degrees of freedom between Model 1 and Model 5, a calculation of the delta chi-square yielded a value ( $\Delta\chi^2 = .121.446$ ) that was not significant. Therefore, Model 1 was kept as the best fit to the data.



Table 10

*Fit Indices for Structural Models*

Model	$\chi^2$	<i>df</i>	Root-mean-square error of approximation	Standardized root-mean-square residual	Comparative fit index	$R^2$
1. LMX → procedural justice → performance appraisal satisfaction	480.04	150	.088	.0471	.915	.759
2. LMX + procedural justice → performance appraisal satisfaction and LMX → performance appraisal satisfaction	479.52	149	.089	.0471	.915	.766

Note.  $R^2 = R^2$  of performance appraisal satisfaction.

Table 11

*Fit Indices for Structural Models With Deleted Item Models*

Model	$\chi^2$	<i>df</i>	Root-mean-square error of approximation	Standardized root-mean-square residual	Comparative fit index	$R^2$
1. LMX → procedural justice → performance appraisal satisfaction	480.04	150	.088	.0471	.915	.759
2. LMX + procedural justice → performance appraisal satisfaction and LMX → performance appraisal satisfaction	479.52	149	.089	.0471	.915	.766
3. Model 1 without Item PJ2	388.43	133	.082	.0437	.931	.764
4. Model 1 without Item PJ6	423.22	133	.088	.0437	.923	.762
5. Model 1 without Items PJ2 and PJ6	358.59	117	.085	.0444	.932	.764

Note.  $R^2 = R^2$  of performance appraisal satisfaction.

**Discussion.** Supporting the prior theory and research outlined by Dusterhoff et al. (2014) and Pichler et al. (2015), this study demonstrated the positive relationships between LMX, procedural justice, and performance appraisal satisfaction. Additionally, procedural justice was shown to be a strong mediator between LMX and performance appraisal satisfaction. However, the correlations among these relationships were very strong, which indicated a lack of discriminant validity; that is, the measurements appeared to be too related.

The first strong correlation involved the path from LMX to procedural justice. The strong path could be explained in part because managers typically communicate, appraise, and conduct employees' performance appraisal. Therefore, perhaps regardless of the amount of procedural justice the organization applies to its performance management policies and procedures, employees perhaps attribute the level of justice to their manager. The second strong correlation, procedural justice and performance appraisal satisfaction, can possibly be explained by the elements of procedural justice, such as employee voice and the opportunity to express one's feelings. Considering that a performance appraisal is essentially a judgment of one person over another, employees who experience opportunities to tell their side of the story may have responded with higher degrees of satisfaction. The third strong relationship is the mediating relationship of procedural justice between LMX and performance appraisal satisfaction. This is perhaps explained by the fact that the performance appraisal process is an integration of all the appraisal activity players and elements. The manager, employee, process, judgment, and appraisal session are connected and overlapping elements.

Nonetheless, the strength of the correlations indicated a lack of discriminant validity, which is an indicator of common method bias (Podsakoff, MacKenzie, Lee, & Podsakoff, 2003). Although common methods bias was not mentioned by Dusterhoff et al. (2014), a review of the

study's correlations in the multiple regression analysis using five total constructs and no mediation indicated similarly strong correlations between LMX, performance appraisal satisfaction, and justice perceptions. Additionally, in Pichler et al. (2015), the structural equation modeling mediated-moderated study used six constructs and a variety of progressive models to determine the best fitting model. Correlations between LMX, performance appraisal satisfaction, and procedural justice variables indicated lower values. Perhaps the simplicity of the Pilot Study 2 theoretical model contributed to the common method bias due to the limited statistical approaches that could be applied.

Conversely, using the list of common method bias sources provided by Podsakoff et al. (2003), this study could have been affected by at least four potential causes. In order of research steps, the first cause could have been that the items of the three measures were too similar in wording or meaning. To address this cause, the researcher needed to determine which measures are similar or determine the common elements and eliminate or minimize them in the design of the study. Second, *item context influence* could have played a role to item priming. Although the dependent variable question was positioned first in the survey, the survey included an introductory paragraph that outlined that the survey was meant to examine the effect of an employee's perception of procedural justice and the strength of LMX on the employee's perception of performance appraisal satisfaction. This introduction may have prejudiced some participants toward the constructs. Third, the variables were measured at the same point in time, and this event could have produced artificial judgments by the participants. Bias is reduced when the participants have stronger psychological separation between the constructs (Podsakoff et al., 2003). Last, *common rater effect* could have played a role because all the participants were employees; thus the data belonged to one side of the manager–employee relationship.

## **Lessons Learned From the Pilot Studies**

Three lessons were applied from the pilot studies to the main study. First, the issue of item context influence was addressed in the survey instrument. The researcher removed any wording that possibly primed the participant toward performance appraisal satisfaction based upon his or her manager relationship. The researcher replaced the wording with a more generic statement so that there was a stronger separation of the constructs for the participant. Second, although Pilot Study 1 indicated the performance rating control variable was an impotent control variable and the researcher removed it from the analysis, all controls variables were kept for the main study. The main study's analysis revealed no such findings. Third, Pilot Study 2 revealed that two items could be removed to reduce discriminant validity, which is an indicator of common method bias. However, the Pilot Study 2 revealed that removing the items did not significantly decrease discriminant validity, so the items were not removed in the main study.

## **Main Study Theory and Hypotheses**

Given the factors affecting performance appraisal satisfaction, this study was underpinned by leadership, justice, and communication theories. Specifically, research studies related to performance appraisal satisfaction are underpinned by LMX theory and organizational justice theory (Dusterhoff et al., 2014; Gruman & Saks, 2011; T. Kim & Holzer, 2014; Pichler et al., 2015; Saks & Gruman, 2011) as well as one of the organizational justice components: procedural justice (Caputo, 2007; Dusterhoff et al., 2014; Pichler et al., 2015). It is generally well established across the LMX, organizational justice, and performance literatures that LMX is positively related to procedural justice and that procedural justice is positively related to performance appraisal satisfaction (Pichler et al., 2015). Also, the relationships between media

richness and LMX (Hakonen & Lipponen, 2008) and between communication frequency and LMX (Kacmar et al., 2003) have been well-established.

A question that had not been adequately addressed is the extent to which employee appraisal reactions, in this case, performance appraisal satisfaction, are a function of the LMX quality and procedural justice relationship when a distributed workplace arrangement exists. LMX theory would indicate that the exchange of resources, such as the richness and frequency of communication, is essential to the quality of the manager–employee relationship (Wayne et al., 2002).

The notion that the communication interchange of distributed manager–employee dyads versus collocated dyads is inferior has been fostered by media richness theory. This theoretical construct maintains that face-to-face communication is superior to all other communication, including e-mail, telephone, and videoconferencing, because it has the most communication pathways and thus allows for the transmission of various types of information (Daft & Lengel, 1986; Purvanova, 2014). Equally, the more frequently an employee in a high-quality LMX relationship communicates with his or her manager, the better the manager feels about the relationship (Kacmar et al., 2003). This logic indicates that communication frequency amplifies a low- or high-quality LMX relationship. However, in distributed workplace arrangements, the opportunities to experience rich and frequent communication are more limited than for those in collocated arrangements (Golden & Veiga, 2008). Thus, the first two hypotheses tested in this study were as follows:

*H<sub>1</sub>: Distributed workplace arrangements will moderate the positive relationship between media richness and LMX, such that the relationship will be weaker when a distributed workplace arrangement is present than when it is not.*

*H<sub>2</sub>: Distributed workplace arrangements will moderate the positive relationship between communication frequency and LMX, such that the relationship will be weaker when a distributed workplace arrangement is present than when it is not.*

Comparable to LMX, procedural justice has been found to be positively related to performance appraisal satisfaction (Pichler et al., 2015). Justice theories posit that voice is important to employees because of its influence on process outcomes such as performance appraisal satisfaction (Lind & Tyler, 1988). Justice perceptions are influenced by communication mediums (Lind & Tyler, 1988). In distributed workplace arrangements, the opportunities to express one's voice are limited to communication mediums enabled by technology (e.g., e-mail, telephone). Consequently, distributed employees rely on a limited number of procedural justice cues (Hakonen & Lipponen, 2008; Westerman et al., 2014). Thus, the third hypothesis tested was as follows:

*H<sub>3</sub>: Distributed workplace arrangements will moderate the positive relationship between LMX and procedural justice, such that the relationship will be weaker when a distributed workplace arrangement is present than when it is not.*

Finally, employee reactions, such as performance appraisal satisfaction, are influenced by the social context in which they reside (Keeping & Levy, 2000; Pichler, 2012). Social context is comprised of distal and proximal variables. A distributive workplace arrangement is an example of a distal variable because it involves organizational structures and workforce composition. Performance management is by far the biggest management challenge within the context of a distributed workplace arrangement. The nature of this arrangement requires managers to do many performance management activities well (Cascio, 2000). However, the literature has revealed that managers are not executing performance appraisals well (Kondrasuk, 2012), and

they are not satisfied with their performance appraisals (Buckingham & Goodall, 2015; Cunningham, 2015; Morris, 2014). Distributive workplace arrangements place a greater strain on performance appraisal satisfaction due to less direct performance observations (Golden et al., 2009), the need for different or increased communication (Farr et al., 2015), and the sometimes recalcitrant behavior of distributed employees (Brewer, 2015). Thus, the fourth and fifth hypotheses tested were as follows:

*H<sub>4</sub>: Distributed workplace arrangements will moderate the positive relationship between procedural justice and performance appraisal satisfaction, such that the relationship will be weaker when a distributed workplace arrangement is present than when it is not.*

*H<sub>5</sub>: Distributed workplace arrangement will be negatively related to performance appraisal satisfaction.*

### **Main Study Design**

A quantitative cross-sectional research design was used to examine these relationships. The study involved collecting data at a single point in time to collect a body of information in connection with more than two variables examined to detect relationships (Bryman & Bell, 2011). The study was quantitative in that all variable data were measures established through quantitative survey responses and the study used statistical testing to determine correlations (Bryman & Bell, 2011). The study used a positivist approach. Study properties were measured through objective methods rather than inferred subjectively through sensation, reflection, or intuition. To expound, a quantitative ex post facto design method was used because the study was nonexperimental and the researcher had limited opportunity to manipulate or control variables in the study (Bryman & Bell, 2011). Hierarchical regression analyses were used

because it is the most straightforward way to test the hypotheses, and it allows for clear and simple handling of the control variables (Hayes, 2013). Additionally, regression analysis was used in related performance appraisal studies (Pichler, 2012).

### **Main Study Population and Sample**

The population for this study was full-time employees at or over the age of 18 who worked in the United States for U.S.-based organizations and who had a performance appraisal in the past 24 months. The age and U.S. qualifications were desired because these employees were most likely to have had a manager and experienced a performance appraisal.

The researcher leveraged professional contacts primarily from financial and professional services industries to gather the population. Accordingly, the sample was a convenience sample (Bryman & Bell, 2011). This convenience sample is compelling in part because with over six million employees (U.S. Department of Labor, 2015), the financial services industry has local, regional, and national locations. Subsequently, the industry is more likely to have collocated and distributed workplace arrangements. Also, due to the formal business nature and the increased regulation and scrutiny of this industry, adherence to performance appraisals is keen (T. Wilson, Wells, Little, & Ross, 2014).

Study participants were recruited primarily in three ways. The first strategy involved contacting the chief HR officer (CHRO) or key leaders of 10 large regional U.S. bank organizations for permission and distribution of the survey. The second strategy involved contacting the American Banker Association Professional Development Council to connect the researcher to the organization's membership group. The third strategy involved contacting leaders of professional services organizations (e.g., consulting services) for permission and distribution of the survey.



A power analysis was conducted using G\*Power 3.1.9.2 to determine how many participants were needed. The power analysis was based on a multiple linear regression with 11 predictors (i.e., the highest number of predictors used in the steps of the hierarchical regression analyses). Assuming a medium effect size of .15, a power level of .80, and a significance level of .05, the minimum number of participants needed to obtain statistically valid results was 123.

### **Main Study Measures**

This study used previously validated measures. These measures were chosen based upon their measurement properties and their use in related research. Permission to use each measure was obtained (see Appendices A, B, C, and D).

**Performance appraisal satisfaction.** Following similar performance appraisal studies (Dusterhoff et al., 2014; Pichler, 2012), performance appraisal satisfaction was measured using four items on a 5-point scale (Dusterhoff et al., 2014). Sample items included “I have positive expectations of future performance review meetings” and “I agreed with my performance review result” (see Appendix E). The Cronbach alpha coefficient was  $\alpha = .859$ .

**Leader–member exchange.** Similar to other performance appraisal studies (Dusterhoff et al., 2014; Pichler, 2012), LMX was measured using seven items on a 5-point scale (Graen & Uhl-Bien, 1995). Sample items included “I know where I stand with my supervisor” and “I have enough confidence in my leader that I would defend and justify his/her decision if he/she were not present to do so” (see Appendix F). The Cronbach alpha coefficient was  $\alpha = .922$ .

**Procedural justice.** Following similar performance appraisal studies (Dusterhoff et al., 2014; Pichler, 2012), procedural justice was measured using seven items on a 5-point scale (Colquitt, 2001, p. 389; Colquitt et al., 2005, p. 131). Sample items included “Have you been able to express your views and feelings during those procedures,” “Have those procedures been

applied consistently,” and “Have those procedures been free of bias” (see Appendix G). The Cronbach alpha coefficient was  $\alpha = .909$ .

**Perceived media richness.** Following similar studies (Dennis & Kinney, 1998), perceived media richness was measured using eight items on a 7-point scale (Daft & Lengel, 1986). Lower scores indicated perceptions of a higher degree of media richness. Sample items included “The communication conditions helped us communicate quickly” and “The communication condition under which we communicated helped us to better understand each other” (see Appendix H). The Cronbach alpha coefficient was  $\alpha = .890$ .

**Communication frequency.** Following similar approaches (e.g., Kacmar et al., 2003), communication frequency was measured using eight items on a 5-point scale (McAllister, 1995). Higher scores indicated perceptions of a higher frequency of communication. Sample items included “How frequently do you send your boss an electronic mail message” and “How frequently do you receive phone calls from your boss” (see Appendix I). The Cronbach alpha coefficient was  $\alpha = .850$ .

**Extent of distributed workplace arrangement.** Following similar approaches (e.g., Golden & Veiga, 2005; Golden et al., 2009; Rockmann & Pratt, 2015), the extent of the distributed workplace arrangement was assessed by asking participants to indicate the average number of hours per week spent away from their office virtually or remotely (see Appendix J).

### **Main Study Control Variables**

Control variables can drown out independent variables, so they must be chosen carefully (B. M. Byrne, 2013). Control variables of performance rating, gender, age, functional specialization, organizational tenure, and telecommuting tenure were selected based upon related research and techniques recommended by Carlson and Wu (2011).

Performance rating was a control variable because it can overinfluence performance appraisal satisfaction if not controlled (Dusterhoff et al., 2014; Kuvaas, 2011; Pichler et al., 2015). Gender was a control variable because men and women may experience differing levels of work–family issues (Golden & Veiga, 2005; Kuvaas, 2011), and telecommuting is often viewed as a means to help balance the demands of work and family life (Bailey & Kurland, 2002). Age may play a role in the experiences of distributed workers, thereby affecting performance appraisal satisfaction (Bélanger, 1999). Also, due to the nature of different job functions and their particular performance feedback loops (e.g., sales jobs typically have readily available performance feedback loops), the statistical analysis controlled for functional specialization to prevent any possibility of unintended effects. Similar to other research on distributed workplace arrangements (Golden & Veiga, 2005), functional specialization was noted. For example, does the job require the participant to be on the road or away from the company office? Organizational tenure was a control variable because greater organizational tenure may give some employees more perspective and techniques as to how their organizations manage performance appraisals and communication (Golden & Veiga, 2005). Finally, similar to Golden and Veiga (2005), this study controlled for telecommuting tenure. Respondents were asked how many years they had been in a distributed workplace arrangement to prevent any honeymoon effects (i.e., the dismissal of any existing problems or problems that are not noticeable or are ignored).

### **Main Study Data Collection Procedures**

Written approvals were sought from each organization’s CHRO or business unit leader to conduct the study and for the employees to complete a web-based survey during work hours. Participants were recruited via e-mail by their respective organizations’ CHRO or business unit

leader and were informed that taking part in the study was voluntary and all responses would be confidential. The e-mail was drafted by the researcher (see Appendix K). The researcher had no involvement in collecting e-mail addresses, no knowledge of participant identities, nor any participation in the delivery of the recruitment e-mails.

The survey contained an introduction from the researcher that included the purpose of the study, amount of time required to participate in the survey, acknowledgment that participation was voluntary, confidentiality guarantee, survey participation instructions, researcher information, and the University of Texas at Tyler Institutional Review Board contact information (see Appendix L). The survey was open for 30 business days per organization.

Participants completed an informed consent acknowledgment before they proceeded (see Appendix M). Upon clicking the *Yes, I choose to participate in this study* button on the informed consent page, the participant was able to move to the survey questions. Upon completion of all the questions, the participant clicked the submit survey button to register responses. Potential participants were also able to select the *No, I choose to not participate in this study* button on the informed consent page. Individuals who chose to decline received a thank-you reply and the survey did not proceed.

At least two reminder notices were sent. The researcher notified each organization's CHRO or business unit leader to send each reminder. The first reminder was sent to participants 10 days prior to the survey deadline. The second reminder was sent one day prior to the deadline. At the close of the deadline, the researcher reviewed summary response reports to determine whether the target sample size had been reached. On three occasions, the overall target sample size had not been reached, so the researcher extended the deadline and notified each CHRO or business unit leader. The CHRO or business unit leader determined if they wanted the

organization to continue to participate. The summary response report review method of determining extensions and notifying the CHROs or business unit leaders continued until the target sample size was reached.

### **Main Study Data Preparation**

Upon receipt, the data were screened and prepared. These activities involved addressing missing data, removing incomplete or unengaged responses, and checking for outliers. The data were validated, and the analysis began with a review of the frequencies and percentages for all the demographic variables. Next mean composite scores were created to use the variables in the analyses. Appropriate items were reverse-coded prior to computation.

The composite scores were checked for outliers using standardized values. Next, descriptive statistics, including means and standard deviations, were analyzed (Schumacker & Lomax, 2010). The reliability of the scales were tested and verified using Cronbach's alpha calculations. Prior to the regression analyses, correlation coefficients were computed for the independent and dependent variables. Assumptions for each statistical analysis were also tested. These assumptions included linearity and normality, homoscedasticity, and a lack of multicollinearity. The testing for these assumptions is important to multivariate analysis, and the tests ensure the potential for bias is limited (Tabachnick & Fidell, 2012).

### **Main Study Data Analysis Procedures**

Hierarchical regression analysis was conducted to test  $H_1$  and  $H_2$ . The dependent variable (outcome) for the regression analysis was LMX. In the first step of the regression analysis, the control variables (i.e., performance rating, gender, age, functional specialization, organizational tenure, and telecommuting tenure) were entered into the model. In the second step, media richness, communication frequency, and distributed workplace arrangement were entered into

the model. In the final step, media richness  $\times$  distributed workplace arrangement and communication frequency  $\times$  distributed workplace arrangement interaction terms were entered into the model.

A hierarchical regression analysis was conducted to test H<sub>3</sub>. The dependent variable (outcome) for the regression analysis was procedural justice. In the first step of the regression analysis, the control variables (i.e., performance rating, gender, age, functional specialization, organizational tenure, and telecommuting tenure) were entered into the model. In the second step, LMX and distributed workplace arrangement were entered into the model. In the final step, an LMX  $\times$  distributed workplace arrangement interaction term was entered into the model. If the interaction term is significant in the final step of the model, then H<sub>3</sub> is supported.

A hierarchical regression analysis was conducted to test H<sub>4</sub> and H<sub>5</sub>. The dependent variable (outcome) for the regression analysis was procedural justice. In the first step of the regression analysis, the control variables (i.e., performance rating, gender, age, functional specialization, organizational tenure, and telecommuting tenure) were entered into the model. In the second step, procedural justice and distributed workplace arrangement were entered into the model. In the final step, a procedural justice  $\times$  distributed workplace arrangement interaction term was entered into the model. If the interaction term is significant in the final step of the model, then H<sub>4</sub> would be supported. If the predictor coefficient for distributed workplace arrangement is significant in the final step of the model, then H<sub>5</sub> is supported.

### **Main Study Reliability and Validity**

Throughout this study, reliability and validity were addressed in a number of ways. In the selection of measures, item internal consistency and construct validity was examined using Cronbach's alpha coefficient estimates and correlation coefficients. In the collection of data, the

researcher had stringent procedures to safeguard the survey process from administrative, technical, and physical issues. After the data were collected, incomplete or unengaged responses were removed, and a check for outliers was conducted. Certain assumptions were checked prior to performing data analysis procedures. These included linearity, lack of multicollinearity, and homoscedasticity (Cohen, Cohen, West, & Aiken, 2013).

### **Main Study Assumptions and Limitations**

**Assumptions.** This study operated under two assumptions. First, it was assumed that the participants made a sincere effort to answer all questions thoroughly and thoughtfully. Second, it was assumed that participants responded to the survey questions based upon their most recent performance appraisal session.

**Limitations of the design.** This study was thoughtfully designed but did have at least five design limitations. First, the use of a quantitative design allowed the researcher to address the hypotheses. However, this design did not allow for the examination of the underlying reasons that could better explain the results (Mitchell & Jolley, 2001). Second, the researcher only sought respondents from the United States, which limited generalizability of the results to those who worked in the United States and for U.S. organizations. Third, the measure of frequency communication may not have captured other and newer methods of communication (e.g., social media). An attempt was made to update the communication frequency measure with more contemporary methods (e.g., texts, instant messaging) but perhaps did not include some more common methods. A fourth limitation was common methods bias; that is, variance is due to the type of measurement method used, rather than to the concepts the measures represent (Podsakoff et al., 2003). The final and fifth limitation was that the researcher worked for a regional bank and therefore may have unintentionally included bias in the study.

## **Main Study Ethical Considerations**

After the completion and successful defense of the dissertation proposal, the researcher completed and submitted an application along with the required documents to obtain written authorization from the University of Texas at Tyler Institutional Review Board to conduct the study (see Appendix N). The application was submitted to the dissertation chair to confirm that the application was complete. The dissertation chair forwarded the completed packet to the University of Texas at Tyler Institutional Review Board. Upon attaining written authorization to conduct the study, the researcher proceeded with conducting the study.

## **Summary of Chapter 3**

The preceding chapter categorized the research design and the methodology of this study. The first chapter section explained the purpose of this study, which was to examine the social context relationship of distributed workplace arrangements on performance appraisal satisfaction through LMX theory, procedural justice, media richness, and communication frequency. The second section included four hypotheses and the supporting theoretical foundations. The third section detailed the design of the study, followed by the fourth section that explained the population and sample. The fifth section outlined the control variables. The sixth section detailed the data collection procedures, followed by the seventh section that described the data preparation steps. The data analysis procedures were explained in the eighth section. Steps to check for reliability and validity were discussed in the ninth section. Assumptions and limitations were detailed in the tenth section. The chapter ended with a section concerning ethical considerations.



## Chapter 4: Results

### Introduction

This chapter contains the details of the data analysis and results of the study. It has five sections. In the first section, details about the survey responses and characteristics of the sample are presented. The second section contains the results of the interitem reliability analysis for each of the composite variables. The third section includes the details and results of the assumption tests for each statistical analysis. The fourth section presents the details of the analysis and results for each study hypothesis. Finally, the fifth section contains a brief summary.

### Data Collection and Sample Characteristics

Seventeen organizations were invited to participate in the study. Seven organizations accepted the invitation. Accordingly, approximately 258 employees were sent emails to complete the survey. One hundred seventy-three individuals responded to the survey, resulting in a 67% response rate. One participant did not agree to the consent form, three participants were not employed full time, four participants were not working in the United States, 15 participants had employers outside of the United States, five participants did not have a performance appraisal in the last 24 months, and seven participants did not finish all the survey questions. These participants were excluded from the final analysis, which left 138 participants.

Of the final sample of 138 participants, most were female ( $n = 92$ , 66.7%), fell into the 41-50 years old age bracket ( $n = 56$ , 40.6%), worked in the banking/finance/insurance industries ( $n = 78$ , 56.5%), and had spent 6 to 10 years at their current company ( $n = 37$ , 26.8%). The majority reported that their job did not require them to work on the road or away from the office ( $n = 85$ , 61.6%) however, most also reported that they did participate in flexible or alternative workplace arrangements ( $n = 74$ , 53.6%). Correspondingly, the majority of participants

responded that they spent 40 hours or more working on-site ( $n = 67, 48.6\%$ ). Of those who spent time working virtually or remotely, 25 (18.1%) spent 5% of their week or an average of 4 hours ( $n = 34, 24.6\%$ ) doing so. If participants did spend time working virtually or remotely, the majority reported that they had been doing so for 0-2 years ( $n = 57, 41.3\%$ ). Most reported that their last performance appraisal was conducted face-to-face ( $n = 80, 58.0\%$ ) and that they received a rating of above expectations–good ( $n = 63, 45.7\%$ ). Table 12 displays the frequencies and percentages for all demographic variables.

Table 12

*Frequencies and Percentages for Demographic Variables*

Variable	<i>n</i>	%
Gender		
Female	92	66.7
Male	46	33.3
Age		
22-30	12	8.7
31-40	18	13.0
41-50	56	40.6
51-60	42	30.4
61-70	10	7.2
Job requires working on the road/away from the office		
Yes	53	38.4
No	85	61.6
Participate in flexible/alternative work arrangement		
Yes	74	53.6
No	64	46.4
Average weekly hours spent working virtually/remotely (distributed workplace arrangement)		
0	32	23.2
4	34	24.6
8	17	12.3
12	7	5.1
16	11	8.0
20	3	2.2
24	3	2.2
28	1	0.7

(continued)

Variable	<i>n</i>	%
32	3	2.2
36	2	1.4
40 or more	25	18.1
Years spent working virtually/remotely to any extent (telecommuting tenure)		
0-2	57	41.3
3-5	32	23.2
6-10	23	16.7
11-15	21	15.2
21-25	4	2.9
25+	1	0.7
Years spent at current company (organizational tenure)		
0-2	57	41.3
3-5	32	23.2
6-10	23	16.7
11-15	21	15.2
21-25	4	2.9
25+	1	0.7
Industry (functional specialization)		
Academia/Education	15	10.9
Accounting	1	0.7
Banking/Finance/Insurance	78	56.5
Consulting	6	4.3
Engineering	1	0.7
Healthcare	2	1.4
Hotel/Restaurant	1	0.7
HR/Recruitment	1	0.7
Information technology	20	14.5
Legal	1	0.7
Manufacturing	1	0.7
Marketing	1	0.7
Mining/Oil and gas	1	0.7
Professional services	2	1.4
Retail buying/Merchandising/Sales	2	1.4
Sales	1	0.7
Transportation/Warehousing	1	0.7
Other	3	2.2
Performance review format		
Face-to-face	80	58.0
Via video conference	3	2.2
Via telephone	48	34.8
Via an exchange of notes, e-mails, or documents	5	3.6
Other	2	1.4

(continued)

Variable	<i>n</i>	%
Last performance rating		
None	2	1.4
Meets expectations-medium	39	28.3
Above expectations-good	63	45.7
Exceeds expectations-excellent	34	24.6

*Note.* Not all percentages may add to 100.0% due to rounding error.

To use performance appraisal satisfaction, LMX, procedural justice, communication frequency, and perceived media richness as variables in the analyses, the mean composite scores needed were created. For performance appraisal satisfaction, the average of items Q9-Q12 was taken. For LMX, the average of Q14-Q20 was taken. The mean of Q22-Q29 was used to create the variable of procedural justice. To create communication frequency, the average of Q31-Q38 was used, and to create the variable of media richness, the average of Q44-Q51 was used. Appropriate items were reverse-coded prior to computation. This allowed five single variables to be used in the analysis.

The composite scores were checked for outliers using standardized values. Tabachnick and Fidell (2012) suggested that scores with standardized values greater than 3.29 or less than -3.29 should be considered outliers. However, no outliers were found in the data. On average, participants reported a performance appraisal satisfaction score of 3.84 ( $SD = 0.84$ ), a LMS score of 4.00 ( $SD = 0.75$ ), a procedural justice score of 3.66 ( $SD = 0.78$ ), a communication frequency score of 2.68 ( $SD = 0.82$ ), and a perceived media richness score of 5.17 ( $SD = 1.24$ ). Table 13 displays descriptive statistics for each of the composite variables.

Table 13

*Descriptive Statistics for Composite Variables*

Variable	Min	Max	<i>M</i>	<i>SD</i>
Performance appraisal satisfaction	1.00	5.00	3.84	0.84
Leader–member exchange	1.60	5.00	4.00	0.75
Procedural justice	1.75	5.00	3.66	0.78
Communication frequency	1.00	4.80	2.68	0.82
Perceived media richness	1.50	7.00	5.17	1.24

**Reliability of the Measures**

To determine the reliability of the composite scores, Cronbach’s alpha was used. The alpha values were interpreted using the guidelines suggested by George and Mallery (2010), where  $\alpha > .9$  excellent,  $>.8$  good,  $>.7$  acceptable,  $>.6$  questionable,  $>.5$  poor, and  $\leq .5$  unacceptable. Reliability scores for performance appraisal satisfaction ( $\alpha = .87$ ), LMX ( $\alpha = .90$ ), procedural justice ( $\alpha = .89$ ), and communication frequency ( $\alpha = .81$ ) were all good. Reliability for media richness was excellent ( $\alpha = .92$ ). Results of Cronbach’s alpha for the composite scores are presented in Table 14.

Table 14

*Cronbach’s Alpha Reliability for Composite Scores*

Composite score	$\alpha$	Number of items
Performance appraisal satisfaction	.87	4
Leader–member exchange	.90	7
Procedural justice	.89	8
Communication frequency	.81	8
Perceived media richness	.92	8

**Correlation Coefficients**

Prior to the regression analysis, bivariate Pearson correlations were computed for the independent and dependent variables. Table 15 displays the correlation coefficients. Distributed workplace arrangement was significantly negatively related to communication frequency

( $r = -.22, p = .011$ ). Media richness ( $r = .61, p < .001$ ), performance appraisal satisfaction ( $r = .57, p < .001$ ), and procedural justice ( $r = .72, p < .001$ ) were all significantly positively related to LMX. Performance appraisal satisfaction ( $r = .35, p < .001$ ) and procedural justice ( $r = .55, p < .001$ ) were both significantly positively related to media richness. Finally, procedural justice was significantly positively related to performance appraisal satisfaction ( $r = .70, p < .001$ ).

Table 15

*Correlation Coefficients*

Variable	1	2	3	4	5
1. Communication frequency	-				
2. Distributed workplace arrangement	-.22*	-			
3. Leader–member exchange	.13	.02	-		
4. Perceived media richness	.08	-.06	.61***	-	
5. Performance appraisal satisfaction	-.02	-.03	.57***	.35***	-
6. Procedural justice	-.03	.02	.72***	.55***	.70***

\* $p < .05$ . \*\*\* $p < .001$ .

**Assumptions Testing**

The assumptions for each statistical analysis were tested prior to analysis. Specifically, the assumptions for hierarchical regression included linearity, normality, homoscedasticity, and lack of multicollinearity. The assumptions of linearity and normality were tested by an examination of normal P-P plots (see Figures 5-7). The data did not significantly deviate from the diagonal, so the assumptions of linearity and normality were met for each analysis. The assumption of homoscedasticity was tested by examination of scatterplots of residuals versus predicted values (see Figures 8-10). The data were equally distributed around zero, so the assumption of homoscedasticity was met for each analysis. Finally, the lack of multicollinearity was tested using variance inflation factors (VIF). According to Stevens (2009), VIF values greater than 10 indicate the presence of multicollinearity. All VIF values were below 10 (see regression Tables 16, 17, and 18), so this assumption was met for each analysis.

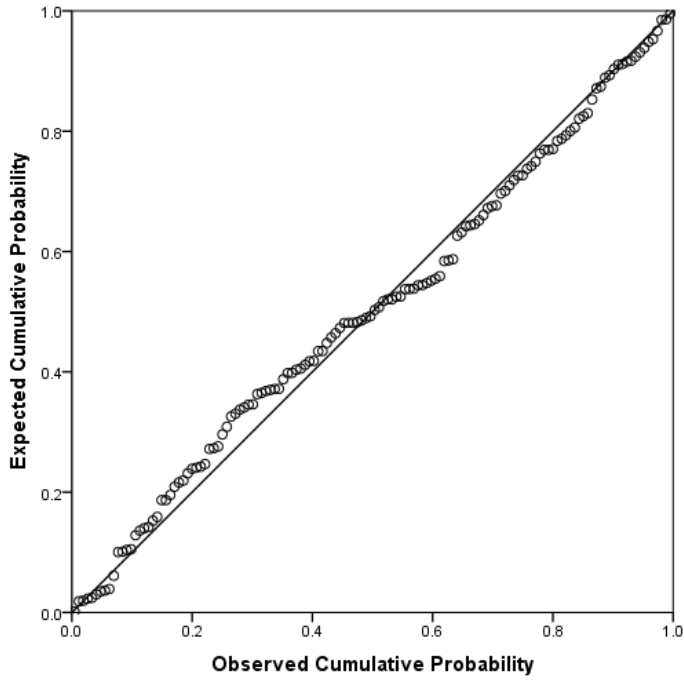

Figure 5. Normal P-P plot (Hypotheses 1 and 2).

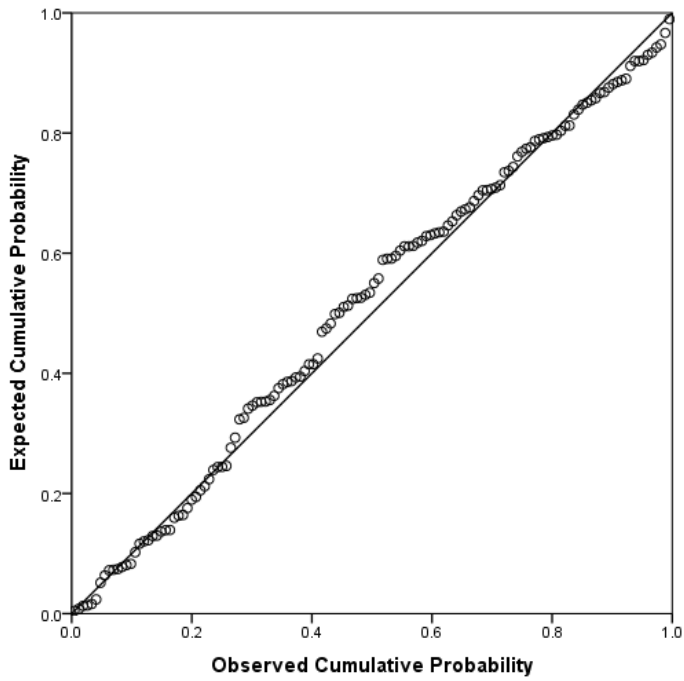

Figure 6. Normal P-P plot (Hypothesis 3).

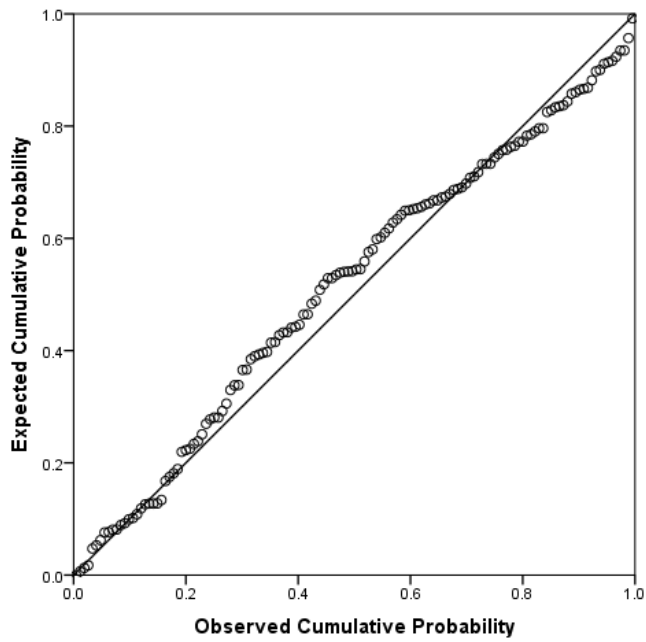

Figure 7. Normal P-P plot (Hypotheses 4 and 5).

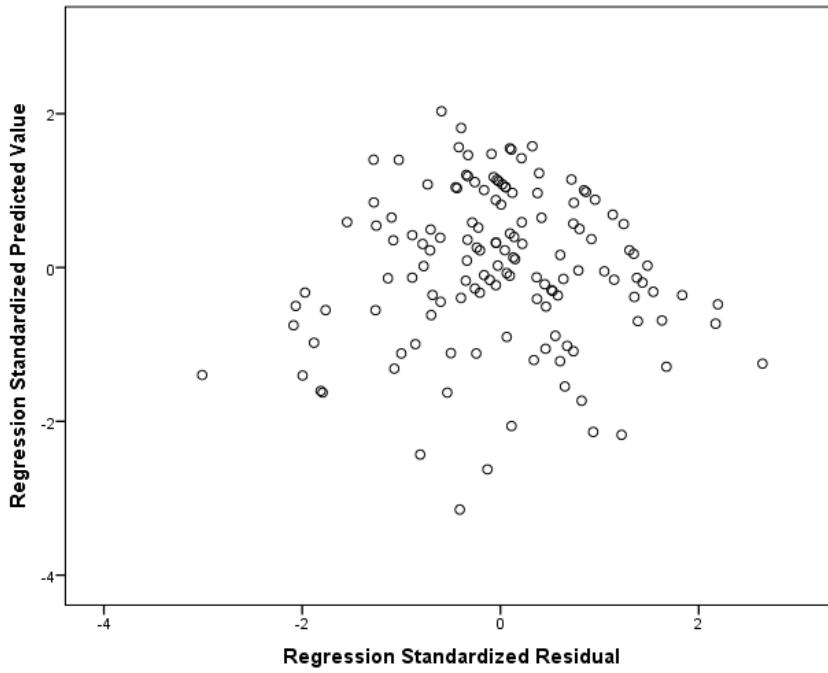

Figure 8. Scatterplot (Hypotheses 1 and 2).



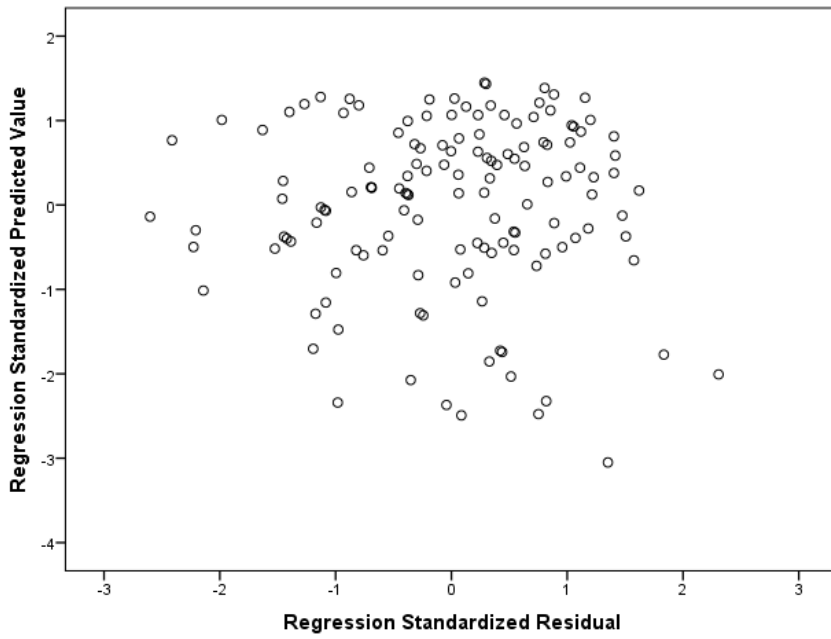

Figure 9. Scatterplot (Hypothesis 3).

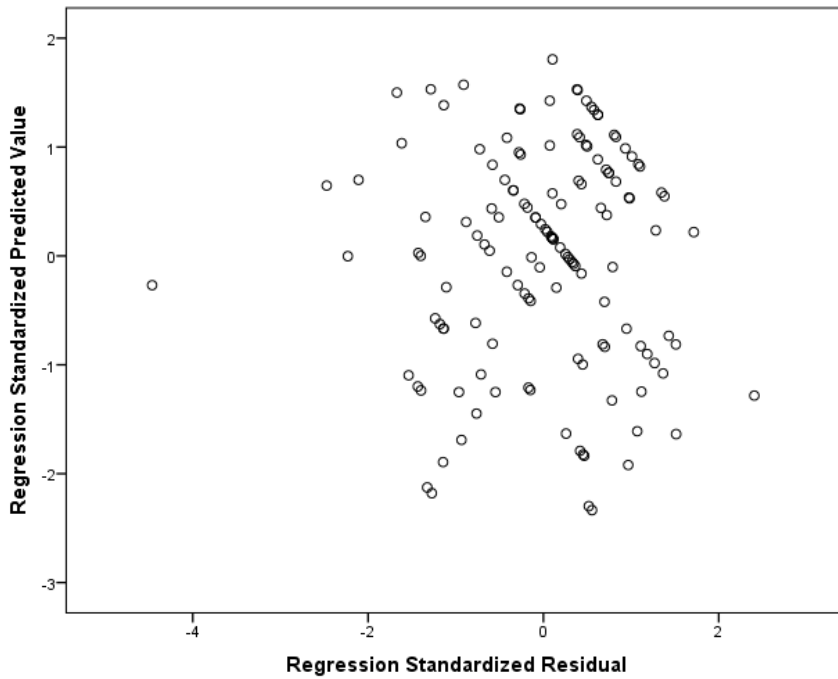

Figure 10. Scatterplot (Hypotheses 4 and 5).

## Hypothesis Testing

### Hypotheses 1 and 2.

*H<sub>1</sub>: Distributed workplace arrangements will moderate the positive relationship between media richness and LMX, such that the relationship will be weaker when a distributed workplace arrangement is present versus when it is not.*

*H<sub>2</sub>: Distributed workplace arrangements will moderate the positive relationship between communication frequency and LMX, such that the relationship will be weaker when a distributed workplace arrangement is present versus when it is not.*

To assess H<sub>1</sub> and H<sub>2</sub>, a hierarchical regression was performed. The dependent variable in this analysis was LMX. For this analysis, the control variables of performance rating, gender, age, functional specialization, organizational tenure, and telecommuting tenure were first entered into the model. Next, media richness, communication frequency, and distributed workplace arrangement were added to the model in Step 2. In Step 3, the terms for the interactions between media richness and distributed workplace arrangement (MR × DWA) and between communication frequency and distributed workplace arrangement (CF × DWA), were added.

The results of Step 1 of the hierarchical regression were significant ( $F(6, 131) = 4.54, p < .001, R^2 = .17$ ), which indicated that performance rating, gender, age, functional specialization, organizational tenure, and telecommuting tenure significantly predicted LMX at Step 1. The coefficient of determination ( $R^2$ ) value indicated that these variables accounted for 17% of the variability in LMX.

The results of Step 2 of the hierarchical regression were also significant ( $F(9, 128) = 12.80, p < .001, R^2 = .47$ ), which indicated that the combination of control variables from Step 1 and media richness, communication frequency, and distributed workplace arrangement

significantly predicted LMX at Step 2. The  $R^2$  value indicated that these variables accounted for 47% of the variability in LMX or 30% more than the control variables alone. The  $R^2$  change from Step 1 to Step 2 was significant ( $p < .001$ ), which indicated that the addition of media richness, communication frequency, and distributed workplace arrangement at Step 2 accounted for significantly more variance in LMX compared to Step 1.

The results of Step 3 of the hierarchical regression were also significant ( $F(11, 126) = 10.31, p < .001, R^2 = .47$ ), which indicated that the set of control variables, independent variables, and interaction terms significantly predicted LMX at Step 3. The  $R^2$  value indicated that these variables accounted for 47% of the variability in LMX or approximately the same amount as Step 2. The  $R^2$  change from Step 2 to Step 3 was not significant ( $p = .990$ ), which indicated that the addition of interaction terms at Step 3 did not account for significantly more variance in LMX compared to Step 2.

Media richness was a significant positive predictor of LMX in the final step ( $B = 0.34, p < .001$ ), which indicated that as media richness scores increased, LMX scores also tended to increase. The interaction between media richness and distributed workplace arrangement ( $MR \times DWA$ ) was not significant ( $B = 0.00, p = .885$ ). This indicated that distributed workplace arrangement did not moderate the relationship between media richness and LMX. Therefore,  $H_1$  was not supported. The interaction between communication frequency and distributed workplace arrangement ( $CF \times DWA$ ) was not significant ( $B = 0.00, p = .885$ ). This indicated that distributed workplace arrangement did not moderate the relationship between communication frequency and LMX. Therefore,  $H_2$  was not supported. The results of the hierarchical regression appear in Table 16.

Table 16

*Hierarchical Regression Predicting LMX*

Source	<i>B</i>	<i>SE</i>	$\beta$	<i>t</i>	<i>p</i>	VIF
Step 1						
Performance rating	0.35	0.07	0.40	4.93	<.001	1.06
Gender	0.27	0.14	0.17	1.97	.051	1.22
Age	0.01	0.06	0.02	0.21	.838	1.12
Functional specialization	-0.02	0.01	-0.15	-1.76	.081	1.21
Organizational tenure	-0.02	0.04	-0.04	-0.45	.651	1.16
Telecommuting tenure	0.01	0.05	0.02	0.23	.818	1.11
Step 2						
Performance rating	0.24	0.06	0.28	4.06	<.001	1.13
Gender	0.22	0.11	0.14	1.98	.050	1.24
Age	-0.01	0.05	-0.02	-0.26	.796	1.18
Functional specialization	-0.02	0.01	-0.19	-2.49	.014	1.40
Organizational tenure	0.00	0.03	-0.01	-0.12	.904	1.18
Telecommuting tenure	-0.01	0.04	-0.01	-0.14	.893	1.14
Media richness	0.34	0.04	0.56	8.44	<.001	1.07
Communication frequency	0.05	0.06	0.05	0.80	.425	1.10
Distributed workplace arrangement	0.01	0.01	0.12	1.67	.098	1.30
Step 3						
Performance rating	0.24	0.06	0.28	4.03	<.001	1.14
Gender	0.23	0.11	0.14	1.97	.051	1.24
Age	-0.01	0.05	-0.02	-0.25	.806	1.20
Functional specialization	-0.02	0.01	-0.19	-2.44	.016	1.42
Organizational tenure	0.00	0.03	-0.01	-0.12	.904	1.18
Telecommuting tenure	-0.01	0.04	-0.01	-0.13	.894	1.17
Media richness	0.34	0.04	0.56	8.32	<.001	1.08
Communication frequency	0.05	0.06	0.06	0.80	.427	1.13
Distributed workplace arrangement	0.01	0.01	0.12	1.55	.124	1.48
MR x DWA	0.00	0.01	-0.01	-0.15	.885	1.11
CF x DWA	0.00	0.01	0.00	0.03	.973	1.26

*Note.* Step 1:  $F(6, 131) = 4.54, p < .001, R^2 = .17$ . Step 2:  $F(9, 128) = 12.80, p < .001, R^2 = .47$ . Step 3:  $F(11, 126) = 10.31, p < .001, R^2 = .47$ .

**Hypothesis 3.**

$H_3$ : *Distributed workplace arrangement will moderate the positive relationship between LMX and procedural justice, such that the relationship will be weaker when a distributed workplace arrangement is present versus when it is not.*

To assess the above hypothesis, a hierarchical regression was performed. The dependent variable in this analysis was procedural justice. For this analysis, the control variables of performance rating, gender, age, functional specialization, organizational tenure, and telecommuting tenure were first entered into the model. Next, LMX and distributed workplace arrangement were added to the model in Step 2. In Step 3, the term for the interaction between LMX and distributed workplace arrangement ( $LMX \times DWA$ ) was added.

The results of Step 1 of the hierarchical regression were significant ( $F(6, 131) = 4.39, p < .001, R^2 = .17$ ), which indicated that performance rating gender, age, functional specialization, organizational tenure, and telecommuting tenure significantly predicted procedural justice at Step 1. The  $R^2$  value indicates that these variables accounted for 17% of the variability in procedural justice.

The results of Step 2 of the hierarchical regression were also significant ( $F(8, 129) = 18.88, p < .001, R^2 = .54$ ), which indicated that the set of control variables, as well as LMX and distributed workplace arrangement, significantly predicted procedural justice at Step 2. The  $R^2$  value indicated that these variables accounted for 54% of the variability in procedural justice, or approximately 37% more than the control variables alone. The  $R^2$  change from Step 1 to Step 2 was significant ( $p < .001$ ), which indicated that the addition of LMX and distributed workplace arrangement at Step 2 accounted for significantly more variance in procedural justice compared to the control variables in Step 1.

The results of Step 3 of the hierarchical regression were also significant ( $F(9, 128) = 16.65, p < .001, R^2 = .54$ ), which indicates that the set of independent variables significantly predicted procedural justice at Step 3. The  $R^2$  value indicated that these variables accounted for 54% of the variability in procedural justice, which was approximately the same as seen in Step 2.

The  $R^2$  change from Step 2 to Step 3 was not significant ( $p = .903$ ), which indicated that the addition of the interaction term at Step 3 did not account for significantly more variance in procedural justice compared to Step 2.

LMX was a significant positive predictor of procedural justice in the final step ( $B = 0.70$ ,  $p < .001$ ), which indicated that as LMX scores increased, procedural justice scores also tended to increase. The interaction between LMX and distributed workplace arrangement (LMX  $\times$  DWA) was not significant ( $B = 0.00$ ,  $p = .903$ ). This indicated that distributed workplace arrangement did not moderate the relationship between LMX and procedural justice. Therefore,  $H_3$  was not supported. The results of the hierarchical regression are presented in Table 17.

#### **Hypotheses 4 and 5.**

*H<sub>4</sub>: Distributed workplace arrangement will moderate the positive relationship between procedural justice and performance appraisal satisfaction such that the relationship will be weaker when a distributed workplace arrangement is present versus when it is not.*

*H<sub>5</sub>: Distributed workplace arrangement will be negatively related to performance appraisal satisfaction.*

To assess the above hypotheses, a hierarchical regression was performed. The dependent variable in this analysis was performance appraisal satisfaction. For this analysis, the control variables of performance rating, gender, age, functional specialization, organizational tenure, and telecommuting tenure were first entered into the model. Next, procedural justice and distributed workplace arrangement were added to the model in Step 2. In Step 3, the term for the interaction between procedural justice and distributed workplace arrangement (PJ  $\times$  DWA) was added.

Table 17

*Hierarchical Regression Predicting Procedural Justice*

Source	<i>B</i>	<i>SE</i>	$\beta$	<i>t</i>	<i>p</i>	VIF
Step 1						
Performance rating	0.36	0.07	0.40	4.87	<.001	1.06
Gender	0.24	0.15	0.14	1.61	.109	1.22
Age	-0.02	0.06	-0.02	-0.29	.776	1.12
Functional specialization	-0.02	0.01	-0.17	-1.95	.054	1.21
Organizational tenure	-0.02	0.04	-0.04	-0.42	.673	1.16
Telecommuting tenure	0.01	0.05	0.01	0.14	.886	1.11
Step 2						
Performance rating	0.12	0.06	0.13	1.99	.049	1.26
Gender	0.05	0.11	0.03	0.41	.684	1.25
Age	-0.03	0.05	-0.04	-0.68	.497	1.16
Functional specialization	-0.01	0.01	-0.09	-1.21	.230	1.42
Organizational tenure	0.00	0.03	-0.01	-0.07	.941	1.18
Telecommuting tenure	0.00	0.04	-0.01	-0.10	.918	1.13
LMX	0.69	0.07	0.67	10.12	<.001	1.21
Distributed workplace arrangement	0.01	0.01	0.05	0.69	.490	1.27
Step 3						
Performance rating	0.12	0.06	0.13	1.95	.053	1.28
Gender	0.05	0.11	0.03	0.42	.679	1.26
Age	-0.03	0.05	-0.04	-0.68	.499	1.16
Functional specialization	-0.01	0.01	-0.09	-1.21	.230	1.46
Organizational tenure	0.00	0.03	-0.01	-0.07	.943	1.18
Telecommuting tenure	0.00	0.04	-0.01	-0.09	.925	1.14
LMX	0.70	0.07	0.67	10.07	<.001	1.22
Distributed workplace arrangement	0.01	0.01	0.05	0.70	.486	1.28
LMX $\times$ DWA	0.00	0.01	0.01	0.12	.903	1.06

Note. Step 1:  $F(6, 131) = 4.39, p < .001, R^2 = .17$ . Step 2:  $F(8, 129) = 18.88, p < .001, R^2 = .54$ . Step 3:  $F(9, 128) = 16.65, p < .001, R^2 = .54$ .

The results of Step 1 of the hierarchical regression were significant ( $F(6, 131) = 4.61, p < .001, R^2 = .17$ ), which indicated that performance rating, gender, age, functional specialization, organizational tenure, and telecommuting tenure significantly predicted performance appraisal satisfaction at Step 1. The  $R^2$  value indicated that these variables accounted for 17% of the variability in performance appraisal satisfaction.

The results of Step 2 of the hierarchical regression were also significant ( $F(8, 129) = 17.37, p < .001, R^2 = .49$ ), which indicated that the set of control variables and procedural justice and distributed workplace arrangement significantly predicted performance appraisal satisfaction at Step 2. The  $R^2$  value indicated that these variables accounted for 49% of the variability in performance appraisal satisfaction, or approximately 32% more than the control variables alone. The  $R^2$  change from Step 1 to Step 2 was significant ( $p < .001$ ), which indicated that the addition of procedural justice and distributed workplace arrangement at Step 2 accounted for significantly more variance in performance appraisal satisfaction compared to Step 1.

The results of Step 3 of the hierarchical regression were also significant ( $F(9, 128) = 15.70, p < .001, R^2 = .49$ ), which indicated that the set of independent variables significantly predicted performance appraisal satisfaction at Step 3. The  $R^2$  value indicates that these variables accounted for 49% of the variability in performance appraisal satisfaction, which was approximately the same as seen in Step 2. The  $R^2$  change from Step 2 to Step 3 was not significant ( $p = .204$ ), which indicated that the addition of the interaction term at Step 3 did not account for significantly more variance in performance appraisal satisfaction compared to Step 2. Procedural justice was a significant positive predictor of performance appraisal satisfaction in the final step ( $B = 0.69, p < .001$ ), which indicated that as procedural justice scores increased, performance appraisal satisfaction scores also tended to increase. The interaction between procedural justice and distributed workplace arrangement ( $PJ \times DWA$ ) was not significant ( $B = -0.01, p = .204$ ). This indicated that distributed workplace arrangement did not moderate the relationship between procedural justice and performance appraisal satisfaction. Therefore,  $H_4$  was not supported. Additionally, distributed workplace arrangement was not a significant



predictor of performance appraisal satisfaction ( $B = 0.00, p = .773$ ). Therefore,  $H_5$  was not supported. The results of the hierarchical regression appear in Table 18.

Table 18

*Hierarchical Regression Predicting Performance Appraisal Satisfaction*

Source	<i>B</i>	<i>SE</i>	$\beta$	<i>t</i>	<i>p</i>	VIF
<b>Step 1</b>						
Performance rating	0.38	0.08	0.39	4.81	<.001	1.06
Gender	0.07	0.16	0.04	0.44	.662	1.22
Age	-0.04	0.07	-0.05	-0.61	.546	1.12
Functional specialization	-0.02	0.01	-0.17	-1.97	.051	1.21
Organizational tenure	-0.06	0.05	-0.12	-1.41	.161	1.16
Telecommuting tenure	0.04	0.06	0.06	0.68	.498	1.11
<b>Step 2</b>						
Performance rating	0.13	0.07	0.13	1.96	.053	1.26
Gender	-0.10	0.12	-0.05	-0.78	.435	1.24
Age	-0.03	0.05	-0.03	-0.48	.636	1.16
Functional specialization	-0.01	0.01	-0.05	-0.73	.470	1.44
Organizational tenure	-0.05	0.04	-0.10	-1.51	.134	1.18
Telecommuting tenure	0.04	0.04	0.05	0.80	.426	1.13
Procedural justice	0.69	0.07	0.65	9.59	<.001	1.21
Distributed workplace arrangement	0.00	0.01	-0.02	-0.34	.738	1.27
<b>Step 3</b>						
Performance rating	0.15	0.07	0.15	2.20	.030	1.33
Gender	-0.09	0.12	-0.05	-0.78	.439	1.24
Age	-0.03	0.05	-0.03	-0.46	.645	1.16
Functional specialization	-0.01	0.01	-0.06	-0.76	.452	1.44
Organizational tenure	-0.05	0.04	-0.09	-1.38	.169	1.19
Telecommuting tenure	0.03	0.04	0.04	0.68	.501	1.14
Procedural justice	0.69	0.07	0.64	9.60	<.001	1.21
Distributed workplace arrangement	0.00	0.01	-0.02	-0.29	.773	1.28
PJ $\times$ DWA	-0.01	0.01	-0.08	-1.28	.204	1.08

*Note.* Step 1:  $F(6, 131) = 4.61, p < .001, R^2 = .17$ . Step 2:  $F(8, 129) = 17.37, p < .001, R^2 = .49$ . Step 3:  $F(9, 128) = 15.70, p < .001, R^2 = .49$ .

**Summary of Chapter 4**

The details of the data analysis and results of the study were presented in this chapter.

The first section included descriptive statistics to characterize the survey respondents and describe the variables of interest. The second section contained the results of the Cronbach's

alpha reliability analysis and revealed that each composite variable was reliable. The third section included the details and results of the assumption tests for each statistical analysis. The results of the assumption testing revealed that all the statistical assumptions for the analyses were met.

The fourth section contained the details of the analysis and results for each study hypothesis. Specifically, three hierarchical regressions were conducted to test the hypotheses. The results showed that H<sub>1</sub> and H<sub>2</sub> were not supported; distributed workplace arrangements did not moderate the relationships between media richness and LMX or communication frequency and LMX. Next, the results showed that H<sub>3</sub> was not supported; a distributed workplace arrangement did not moderate the relationship between LMX and procedural justice. Finally, the results showed that H<sub>4</sub> and H<sub>5</sub> were also not supported; distributed workplace arrangements did not moderate the relationship between procedural justice and performance appraisal satisfaction, and a distributed workplace arrangement was not significantly related to performance appraisal satisfaction. The results are summarized in Table 19.

Table 19

*Summary of Hypotheses Results*

Hypothesis	Supported	Not Supported
H <sub>1</sub>	--	✓
H <sub>2</sub>	--	✓
H <sub>3</sub>	--	✓
H <sub>4</sub>	--	✓
H <sub>5</sub>	--	✓

## Chapter 5: Discussion

### Introduction

This chapter contains four sections. The first section is a discussion of the Chapter 4 results and the relationships to the relevant literature. The second section discusses the study's implications to theory, research, HRD research in particular, and the implications for HRD practitioners. The third section outlines the study's limitations. The chapter concludes with seven suggestions for future research.

### Discussion of the Results

This section includes a discussion of each of the hypotheses' results. For each hypothesis, similarities and differences will be compared to the relevant literature. Also, any impacts to the literature will be discussed. In particular, the focus will be on the inclusion of the social contextual variable, distributed workplace arrangement, on existing performance appraisal satisfaction research as it pertains to organizations and HRD.

**Hypotheses 1 and 2.** Hypotheses 1 and 2 predicted a weaker relationship between media richness and LMX, and between communication frequency and LMX, when a distributed workplace arrangement was present than when it was not (see Figure 11). The first similarity between this study's results and the relevant literature is that media richness and communication frequency are significant positive predictors of LMX. Literature has shown that employees who have opportunities to provide and discuss information with their managers are considered more positively and as in-group employees by their managers. These perspectives by managers and employees lead to stronger LMX relationships (Fix & Sias, 2006).

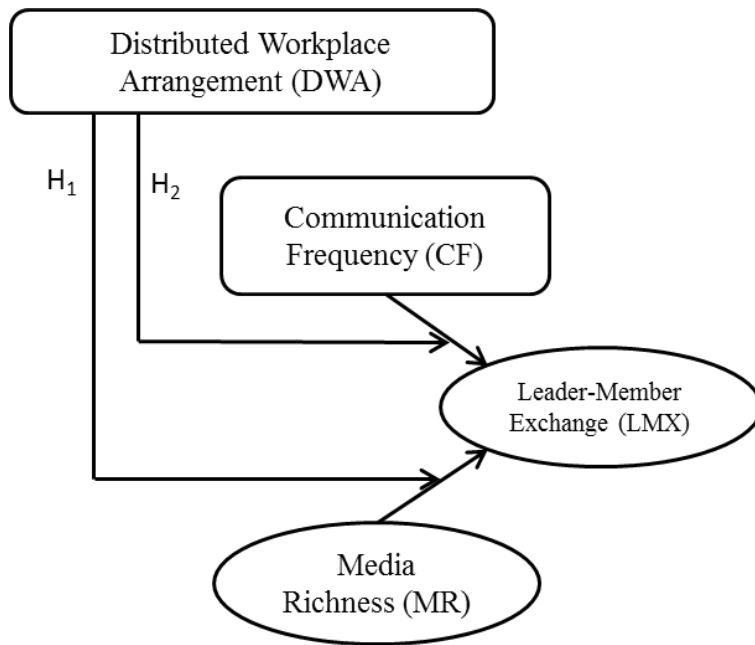

Figure 11. Conceptual model of Hypotheses 1 and 2.

Results of H<sub>1</sub> Step 2 were significant and indicated that the combination of control variables from Step 1 and media richness, communication frequency, and distributed workplace arrangement significantly predicted LMX. The  $R^2$  value indicated that these variables accounted for 47% of the variability in LMX, or 30% more than the control variables alone.

Different from the existing literature, a distributed workplace arrangement variable was added as a social contextual element. Although the variable significantly predicted LMX when combined with the control variables, media richness and communication frequency, it was not enough (Step 3) to account for significantly more variance in LMX compared to Step 2.

The literature and the results of Hypotheses 1 and 2 suggest that technologically enabled tools support the strength of LMX. Advancements in communication (e.g., e-mail, text, instant messaging, videoconferencing) are more commonly used and accepted workplace proxies for communication (Hakonen & Lipponen, 2008; Purvanova, 2014). The value of face-to-face interactions between managers and employees are diminished or are being replaced with these

tools. These tools may be accelerating communication interactions due to their instant and 24/7 platforms. Employees and managers no longer have to wait for the next available meeting. Instead, they can immediately send a text or instant message with the expectation that a reply is quickly forthcoming.

Consequently, technological advancements may change the notion of how media richness theory, which leans heavily in favor of face-to-face interactions (Golden et al., 2009), and the frequency of communication, which has been shown to be an effective performance feedback approach (Kuvaas, 2011; Levy & Williams, 2004), affect LMX strength in today's workplace. These advancements may diminish the impact and relevance of a distributed workplace arrangement on HRD programs and practices such as performance management. Also, these advancements could mean that it is no longer necessary for organizations to provide different or additional training or support for managers and employees who are in virtual or remote relationships. Thus, the organization is able to reallocate resources and productivity.

**Hypothesis 3.** Hypothesis 3 predicted that the relationship between LMX and procedural justice would be weaker when a distributed workplace arrangement was present than when it was not (see Figure 12). The positive relationship of LMX and procedural justice on performance appraisal satisfaction had been revealed in the relevant literature and in the researcher's dual pilot results. In the literature, LMX has been of interest to researchers because of the many perceptions and behaviors it can influence (Graen & Scandura, 1987; Liden et al., 1997). Also, procedural justice theory has been effectively applied to the area of performance management (Pichler, 2009). For example, Jawahar (2007) suggested that procedural justice influences performance appraisal satisfaction with performance feedback.

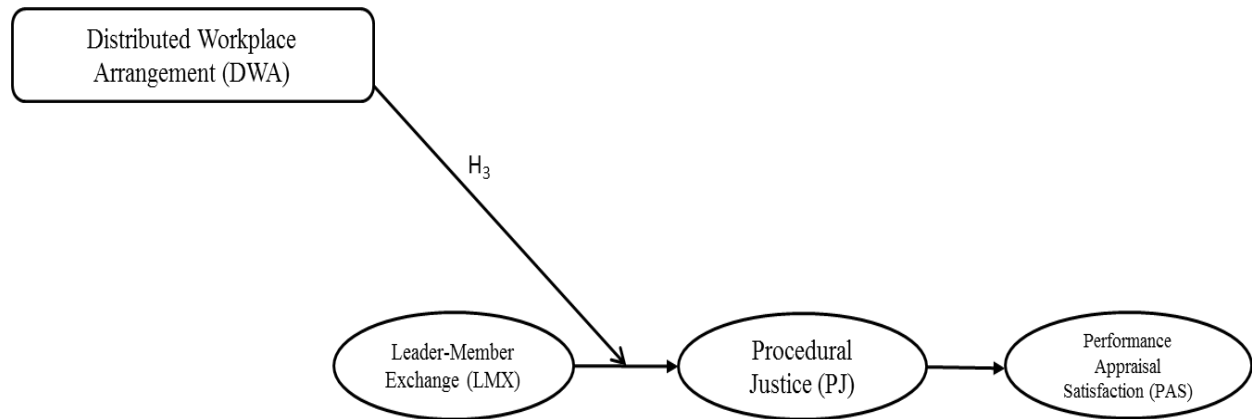

Figure 12. Conceptual model of Hypothesis 3.

Dusterhoff et al. (2014) found that LMX and justice perceptions were interrelated and led to performance appraisal effectiveness. In a related study, Pichler et al. (2015) found that LMX was a significant predictor of employee perceptions of procedural justice, performance ratings, and performance appraisal satisfaction. Procedural justice partially mediated the relationship between LMX and performance appraisal satisfaction. Similarly, the researcher's dual pilot results indicated that LMX, with procedural justice as the mediator, had a significant and positive relationship to performance appraisal satisfaction.

Adding to this research foundation, a distributed workplace arrangement variable was included as a moderator between LMX and procedural justice to understand how social context affects performance appraisal satisfaction. It was revealed in this study that although a distributed workplace arrangement, combined with the control variables and LMX, significantly predicted procedural justice, it was not enough (Step 3) to account for significantly more variance in procedural justice compared to Step 2. This finding indicated that employees working in distributed workplace arrangements do not experience weaker relationships with their managers or weaker procedural justice perspectives, which are both predictors of performance appraisal satisfaction.

Thus, it appears that a distributed workplace arrangement does not affect employee perceptions of procedural justice when a strong manager–employee relationship exists. This perspective leans heavily on the relevant literature that has confirmed that LMX has a significant and positive relationship with performance appraisal satisfaction (Milkovich & Bourdreau, 1997). Milkovich and Bourdreau (1997) noted that performance appraisal satisfaction is comprised of three elements: satisfaction with the rater, satisfaction with the performance appraisal feedback, and satisfaction with the rating. Of these elements, Pooyan and Eberhardt (1989) noted that the first element was the most critical because it involved the manager–employee relationship.

Accordingly, this study supports the view that the role of the manager remains paramount and is tied directly to an organization’s success (Gilley, Boughton, & Maycunich, 1999). The manager’s treatment of his or her employees determines productivity levels because high-quality LMX relationships have increased levels of mutual trust, social support, and employee satisfaction, whereas low-quality relationships are characterized by lower levels of these characteristics (Dansereau et al., 1975; Liden et al., 1997). Specifically, the relationship a manager cultivates with his or her employees is crucial and can outweigh obstacles and geography such as distributed workplace arrangements. Strong manager–employee relationships trump distance.

Similarly, an assumption should not be made that managers intuitively know how to strengthen these manager–employee relationships. It is important to emphasize that managers are the levers to recruit, assess, coach, retain, and motivate the greatest asset of a company: employees. To do this, organizations must provide the tools for managers to be successful versus expecting managers to be successful.

**Hypotheses 4 and 5.** Hypotheses 4 and 5 predicted a weaker relationship between procedural justice and performance appraisal satisfaction when a distributed workplace arrangement was present than when it was not and that a distributed workplace arrangement will have a negative relationship to performance appraisal satisfaction (see Figure 13). The relationship of procedural justice to performance appraisal satisfaction was revealed in the relevant literature and in the researcher’s dual pilot results.

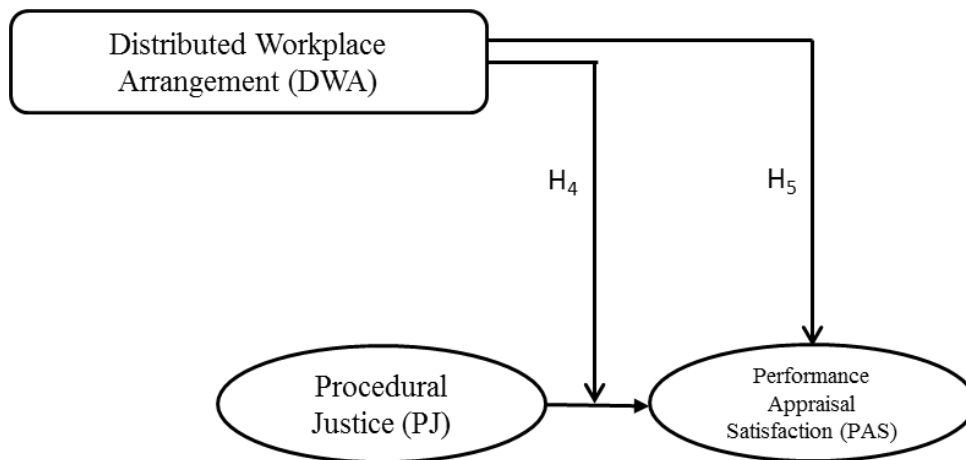

*Figure 13.* Conceptual model of Hypotheses 4 and 5.

To examine these relationships further, this study added distributed workplace arrangements as a social contextual variable. Performance appraisal researchers (Schminke et al., 2000) have largely neglected the greater social context within which fair and unfair interactions occur. Levy and Williams (2004) maintained that “identifying, measuring and defining the organizational context” (p. 883) in which voice and transparency of procedural justice was present was important. Despite the demands to add social contextual variables to performance appraisal studies, this study’s results did not show that social context significantly affected the relationship between procedural justice and performance appraisal satisfaction.

For example, in Hypothesis 4, a distributed workplace arrangement variable was added as a moderator for procedural justice and performance appraisal satisfaction. Although the variable



when combined with the control variables and procedural justice significantly predicted performance appraisal satisfaction, it was not enough (Step 3) to account for significantly more variance in performance appraisal satisfaction compared to Step 2.

Because these findings differ from the existing literature, they demand further investigation. In Kurland and Cooper's (2002) review of telecommuting challenges, they concluded that in order for telecommuting to be a successful workplace arrangement, managers needed to know how to be effective remote mentors and managers, and employees needed forums in which to interact informally. With the advent of social media inside and outside the workplace (e.g., company discussion boards, company chat rooms, online mentoring programs) and performance management programs supported by technology, new and effective forums exist. Thus, perhaps managers and employees use these forums to view, obtain and convey procedural justice and consequently make distributive workplace arrangements negligible.

The literature also indicates that voice and transparency, critical components of procedural justice (Greenberg, 1990; Leventhal, 1980), are more difficult to achieve in distributed workplace arrangements. This study contradicts this position. Managers and employees in distributed workplace arrangements do not have a diminished sense of procedural justice. Undoubtedly, a strong manager-employee relationship, the transparency of employee effort, the progress supported by technology (e.g. OneNote®, MS Project®), and advancements in communication (e.g. email, Skype®, instant messaging, text), enable voice and transparency to exist in the workplace regardless of the type of workplace arrangement.

For Hypothesis 5, the distributed workplace arrangement variable did not have a significant relationship to performance appraisal satisfaction. This finding contradicted the relevant research that maintains that a distributed workplace arrangement will make it more

challenging to provide performance appraisal feedback (Brewer, 2015; Cascio, 2000). For example, Brewer (2015) found that when giving performance criticism, managers often received no reply or negative responses from distributed employees. Managers also noted that necessary performance changes often took longer, and performance criticism was easier to give face-to-face (Brewer, 2015). Similarly, researchers have shown that managers seem to struggle with performance appraisals (Grote, 2011; Kondrasuk, 2012; Pulakos et al., 2012; Spence & Keeping, 2011), especially in distributed workplace arrangements (Cascio, 2000).

Because Hypothesis 5 findings contradicted the existing literature, further explanation is needed. One explanation is that the distributed workplace arrangement has evolved. Previous research has shown that managers tend to rely primarily on fact-based and management-by-objectives type of evidence when assessing remote employees' performance (MacDuffie, 2007). Today's distributed workplace arrangement exists on a more transparent platform and performance transparency is enabled by technology (e.g., electronic performance scorecards, performance management software). This platform can more easily showcase performance results for both managers and employees. Both use the concrete evidence exchanged between them and thus both achieve performance appraisal satisfaction.

Regardless of workplace arrangement, the manager is the integral component of procedural justice and performance appraisal satisfaction. The most effective managers drive for results, support and deliver on the organization's strategies, and engage and motivate employees. Engagement and motivation are required for justice and satisfaction to exist. This study has shown that a manager, regardless of workplace arrangement (distributed or non-distributed) who strives for a productive and strong manager-employee relationship will propel the organization's success.

## **Implications of the Study**

The results of this study advance the theory, research, and practice of performance appraisal satisfaction in the social context of a distributed workplace arrangement.

**Implications for theory.** Theoretically, this study supported positive correlations involving LMX, procedural justice, and performance appraisal satisfaction. The strong paths could be explained in part because managers typically communicate, appraise, and conduct employees' performance appraisal. Therefore, perhaps regardless of the amount of procedural justice the organization applies to its performance management policies and procedures, employees attribute the level of justice to their manager. The second strong correlation, procedural justice and performance appraisal satisfaction, could be explained by the elements of procedural justice, such as employee voice and the opportunity to express one's feelings. The third strong relationship was the mediating effect of procedural justice between LMX and performance appraisal satisfaction, which is perhaps explained by the fact that the performance appraisal process is an integration of all the appraisal players and elements. The manager, employee, process, judgment, and appraisal session are connected and overlapping elements.

To add to the existing knowledge of these constructs in the presence of distributed workplace arrangements, these relationships held firm, which reinforced the constructs' principles. When media richness and communication frequency were added to the hypothesized model, the constructs and their relationships still held firm. Theoretically, this could mean that regardless of the workplace arrangement (distributed or nondistributed), the constructs of media richness, LMX, procedural justice, and performance satisfaction are not significantly affected.

**Implications for research.** This study supported prior performance satisfaction research outlined by Dusterhoff et al. (2014) and Pichler et al. (2015). The findings demonstrated positive

relationships exist between LMX, procedural justice, and performance appraisal satisfaction. Procedural justice was shown to be a strong mediator between LMX and performance appraisal satisfaction. Performance appraisal satisfaction is essential considering the importance organizational leaders put on the activity to drive results and make decisions (Aguinis et al., 2012). Employees' satisfaction with their performance appraisals is linked to an improved understanding between managers and employees, motivation to improve performance, and actual improvement (Burke et al., 1978) and is related to the strength of the manager–employee relationship and procedural justice (Dusterhoff et al., 2014; Pichler et al., 2015).

As past researchers have indicated (Spence & Keeping, 2011), research literature has lagged behind what practitioners are facing in regard to the performance appraisal social context. Thus, this study made two important contributions to research, particularly to the field of HRD. The researcher expanded the existing research literature by adding distributed workplace arrangement to the list of contextual facets in which performance appraisal satisfaction is viewed. Distributed employees were previously rarely used or mentioned in performance appraisal studies (Golden et al., 2009). Given the reality of distributed workplace arrangements, the performance challenges placed upon the manager–employee relationship when the two have infrequent face-to-face interaction, and the dissatisfaction with performance appraisals, this study's perspective was especially value-added. This study's results demonstrated that distributed workplace arrangements do not significantly lessen the employees' perception of LMX, procedural justice, or performance appraisal satisfaction. However, this does not indicate that research using this variable is complete. It would be premature to stop using this variable given that distributed workplace arrangements are quickly becoming, if they have not already

become, the norm. In this regard, researchers should include or note its use in social science studies to explain their findings more fully.

**Implications for business practice.** This study had four implications for HRD, managers, and related business practices. With the proliferation of distributed teams, global teams, collaboration through outsourcing, contract work, mergers, telework, hoteling, multiple-office facilities, and satellite offices, the meaning of going to work is changing (Rockmann & Pratt, 2015). Thus, the first implication is that HRD practitioners must understand how these different workplace arrangements could affect programs and performance management practices in particular, given their importance to organizations (Aguinis, 2013; Judge & Ferris, 1993; Murphy & Cleveland, 1995).

The second implication involves using feedback techniques as proxies for performance appraisals. Because the achievement of effective performance management programs remains an unrealized goal (Levy & Williams, 2004), organizational leaders can proceed with more confidence that new techniques in conducting performance appraisals could work for organizations which have distributed workplace arrangements. Organizational leaders can consider emphasizing more frequent feedback, discussions, observations, and development activities (Buckingham & Goodall, 2015; Javad, 2015) without having to provide different tactics for the management of distributed employees.

The third implication concerns using technology to support procedural justice and performance appraisal satisfaction. Some researchers (Pichler, 2009, 2012; Pichler et al., 2015) consider employee reactions to be the true measures of performance appraisal effectiveness, with organizational justice theory as the bridge between appraisal context and appraisal reactions. According to Pichler (2009, 2012) and Pichler et al. (2015), the employee performance appraisal

reactions of accuracy, fairness, procedural justice, motivation to improve, utility, and satisfaction are the collective measures of performance appraisal effectiveness.

Regarding these reactions, procedural justice has been found to increase an employee's level of performance appraisal satisfaction directly and via the manager–employee relationship. This begins with HRD practitioners applying justice principles to all performance management activities, such as policies, procedures, employee communication, and manager training. It would be prudent of HRD practitioners to consider managers' communication and feedback abilities in the performance appraisal process; otherwise, employees will not buy into the program (Panggabean, 2001; Wittmer et al., 2010). When bundled together, the manager's ability to provide performance feedback and the organization's use of fair and transparent policies and procedures will drive performance appraisal satisfaction. Thus, the third implication is that when using distributed workplace arrangements, a company's technology, communication and performance management technology in particular, must be relevant and used to support transparent justice constructs that lead to performance appraisal satisfaction.

The fourth and most important implication concerns the role of the manager. Managers are primarily responsible for the activities that support the constructs of LMX, procedural justice and performance appraisal satisfaction. Thus, organizations and practitioners need to develop these capabilities in their managers. Skilled managers effectively manage *both* collocated and distributed employees. Distance does not seem to matter when skilled managers are in place.

Thus, recruiting and hiring the right candidate for a manager position is critical. Candidates with managerial skills (e.g. interpersonal, performance coaching, team building) and who understand LMX, justice and communication principles can propel an organization's success by engaging and motivating employees. Additionally, the most successful employees do

not necessarily evolve to be the most effective managers. Organizations must appropriately assess an employee's ability and aspiration to be a manager via training and development programs.

Last, organizations must train, correct, or replace those managers who do not possess the mindsets or skills needed to effectively manage employees regardless of workplace arrangement. Researchers have noted that managers find performance management to be more challenging in distributed manager–employee relationships (Cascio, 2000). However, this study indicated that performance management is perhaps no longer as challenging for virtual arrangements. Thus, practitioners should consider lessening or removing training solutions that stress different techniques for managers who manage distributed employees, especially pertaining to performance appraisals. Practitioners must recognize that distributed employees rely on and use communication technology more frequently (Golden et al., 2009) and this frequency can perhaps compensate for face-to-face interactions. Also, the perception of fairness is dependent upon the richness and frequency of communication exchanges between the manager and the employee (Golden et al., 2009). Today, this perception is facilitated by advancements in technology. Thus, practitioners must provide training that prepares managers to be more effective. Training should include and not be limited to, communication (e.g. frequency, richness, modality), performance coaching (e.g. goal-setting, performance expectations), and justice principles (e.g. voice, transparency).

Given the above implications for practice and the prevalence of distributed workplace arrangements, it should be also noted that organizations and practitioners need to create strategies and environments in which feedback is the norm for all employees. HRD practitioners should ensure that feedback, including critical feedback, is the expectation for highly functioning

(virtual and nonvirtual) manager–employee relationships (Brewer, 2015). This effort will require practitioners to shift organizational cultures toward more developmental mind-sets and provide ongoing reinforcement, training, rewards and other support for managers and employees.

### **Limitations**

Eight limitations should be taken into account when considering the contributions of this study. First, the use of a quantitative design allowed the researcher to address the hypotheses. However, this design did not allow for an examination of the underlying reasons that could better explain the results (Mitchell & Jolley, 2001). Second, this study included only self-reported employee responses. Researchers of future studies should consider using both the manager and the employee to reduce bias (see, for example, Nimon & Astakhova, 2015; Podsakoff et al., 2003). A third limitation was common methods bias; that is, variance due to the type of measurement method used, rather than to the concepts the measures represent (Podsakoff et al., 2003). Fourth, and related to common methods bias, perhaps other measures could have been used that had items that were more distinctive (Podsakoff et al., 2003).

Fifth, as a “one-shot” (Nimon & Astakhova, 2015, p. 9) survey, this study was limited by the employees’ perceptions on a given day and time. Sixth, the researcher only sought respondents from the United States, which limited generalizability of the results to those who worked in the United States and for U.S. organizations. Seventh, the measure for frequency communication may not have captured other and newer methods of communication (e.g., social media). An attempt was made to update the communication frequency measure with more contemporary methods (e.g., texts, instant messaging) but perhaps did not include some more common methods. The final limitation was that the researcher worked for a regional bank and therefore may have unintentionally included bias in the study.



## **Suggestions for Future Research**

This study opens at least seven pathways for future research. First, this research supports the perspectives of scholars (Levy & Williams, 2004) who believe that researchers should continue to study various social context variables that could influence social science constructs. They can involve proximal variables such as performance expectancies, task characteristics (Fletcher & Williams, 1996), and structural variables such as configurations, features, frequency, standards, and legitimacy (Fletcher & Williams, 1996; Levy & Williams, 2004).

Second, due to the importance of performance appraisal satisfaction as established by its research frequency and outcomes (Giles & Mossholder, 1990; Keeping & Levy, 2000; Kuvaas, 2011), it follows that researchers should continue to study the various social context variables that could influence it and performance management. An examination of the social context issues around performance appraisals has not yet been fully explored, given the variety and complexity of the available social context dimensions that can affect performance appraisal satisfaction (Levy & Williams, 2004; Pichler et al., 2015).

Third, these findings challenge researchers to add distributed workplace arrangements as a social contextual variable in business-related studies. This study suggests that distributed workplace arrangements will not significantly affect more contemporary approaches to performance appraisal feedback, such as more frequent performance feedback tactics, as proxies for performance appraisals. However, much more research is necessary to suggest this relationship in other areas of business and performance management in particular.

Fourth, this study represented the employee perspective of the hypotheses. This study could be replicated to represent the managerial perspective; that is, managers who themselves are

remote employees. The number of managers who work remotely has increased (Maurer, 2015) and this population deserves further examination.

Fifth, researchers have made comparisons within a sample of distributed or collocated employees but typically did not compare the two sets (MacDuffie, 2007). This study combined the two sets. Although research has maintained that the tasks, objectives, and mission of distributed and collocated employees did not differ (MacDuffie, 2007), the processes they used to achieve their objectives differed because of the constraints they faced (MacDuffie, 2007). Given the pervasiveness and apparent advantages (Rockmann & Pratt, 2015) to organizations that use distributed employees, it is important for researchers to understand how the two sets compare. Researchers could replicate this design, gather more participants, and compare the results between collocated and distributed employees' results.

Sixth, research regarding procedural justice has revealed that an organization's justice climate may have a broader influence on LMX and performance appraisal satisfaction (Lin, 2015). Given that distributed employees perceive their organizations in a broader way than collocated employees do (Lin, 2015), using procedural justice climate as a proxy for procedural justice may result in different research outcomes.

Seventh, this study could be replicated by replacing performance appraisal satisfaction with system satisfaction (Keeping & Levy, 2000). Performance appraisal satisfaction reflects how satisfied an individual is with the appraisal session, whereas system satisfaction reflects how satisfied one is with the performance management system (Keeping & Levy, 2000). Most of the research on performance appraisal satisfaction has focused on session satisfaction (Giles & Mossholder, 1990). It is important to distinguish between session and system satisfaction given

their conceptual differences and differential relationship correlates (Cawley et al., 1998; Giles & Mossholder, 1990; Keeping & Levy, 2000).

### **Summary of Chapter 5**

This chapter consisted of four sections. The first section contained a discussion of the results in Chapter 4 and the relationships to the relevant literature. The second section included the study's implications to theory and research, especially HRD research and implications to HRD practitioners. The third section consisted of the study's limitations. Finally, seven suggestions for future research were provided.

## References

- Adams, J. S. (1965). Inequity in social exchange. In L. Berkowitz (Ed.), *Advances in experimental social psychology* (Vol. 2). New York, NY: Academic Press.
- Aguinis, H. (2013). *Performance management* (3rd ed.). Upper Saddle River, NJ: Pearson Prentice Hall.
- Aguinis, H., Joo, H., & Gottfredson, R. K. (2012). Performance management universals: Think globally and act locally. *Business Horizons*, 55, 385-392.  
doi:10.1016/j.bushor.2012.03.004
- Allen, T. D., Golden, T. D., & Shockley, K. M. (2015). How effective is telecommuting? Assessing the status of our scientific findings. *Psychological Science in the Public Interest*, 16(2), 40-68. doi:10.1177/1529100615593273
- Andrews, M. C., & Kacmar, K. M. (2001). Discriminating among organizational politics, justice, and support. *Journal of Organizational Behavior*, 22, 347-366. doi:10.1002/job.92
- Arvey, R. D., & Murphy, K. R. (1998). Performance evaluation in work settings. *Annual Review of Psychology*, 49, 141-168.
- Bagozzi, R. P., & Yi, Y. (1988). On the evaluation of structural equation models. *Journal of the Academy of Marketing Science*, 16, 74-94.
- Bailey, D. E., & Kurland, N. B. (2002). A review of telework research: Findings, new directions, and lessons for the study of modern work. *Journal of Organizational Behavior*, 23, 383-400. doi:10.1002/job.144
- Balzer, W. K., & Sulsky, L. M. (1990). Performance appraisal effectiveness. In K. R. Murphy & F. E. Saal (Eds.), *Psychology in organizations: Integrating science and practice*. Hoboken, NJ: Taylor and Francis.

- Becker, T. E. (2005 ). Potential problems in the statistical control of variables in organizational research: A qualitative analysis with recommendations. *Organizational Research Methods, 8*, 274-289.
- Bélanger, F. (1999). Research: Workers' propensity to telecommute: An empirical study. *Information & Management, 35*, 139-153. doi:10.1016/S0378-7206(98)00091-3
- Bell, B. S., & Kozlowski, S. W. J. (2002). A typology of virtual teams: Implications for effective leadership. *Group & Organization Management, 27*, 14-49.
- Bersin, J. (2013, May 6). Time to scrap performance appraisals? *Forbes*. Retrieved from <http://www.forbes.com>
- Blau, P. M. (1964). *Exchange and power in social life*. New York, NY: Wiley.
- Boswell, W. R., & Boudreau, J. W. (2000). Employee satisfaction with performance appraisals and appraisers: The role of perceived appraisal use. *Human Resource Development Quarterly, 11*(3), 283.
- Brewer, P. E. (2015). *International virtual teams: Engineering global success*. Piscataway, NJ: Wiley.
- Brown, M., & Benson, J. (2003). Rated to exhaustion? Reactions to performance appraisal processes. *Industrial Relations Journal, 34*, 67-81. doi:10.1111/1468-2338.00259
- Brown, M., Hyatt, D., & Benson, J. (2010). Consequences of the performance appraisal experience. *Personnel Review, 39*, 375-396. doi:10.1108/00483481011030557
- Bryman, A., & Bell, E. (2011). *Business research methods* (3rd ed.). New York, NY: Oxford University Press.
- Buckingham, M., & Goodall, A. (2015). Reinventing performance management. *Harvard Business Review, 93*, 40-50.

- Buhrmester, M., Kwang, T., & Gosling, S. D. (2011). Amazon's Mechanical Turk a new source of inexpensive, yet high-quality, data? *Perspectives on Psychological Science*, *6*, 3-5.
- Burke, R. J., Weitzel, W., & Weir, T. (1978). Characteristics of effective employee performance review and development interviews: Replication and extension. *Personnel Psychology*, *31*, 903-919. doi:10.1111/j.1744-6570.1978.tb02130.x
- Burton, J. P., Sablinski, C. J., & Sekiguchi, T. (2008). Linking justice, performance, and citizenship via leader-member exchange. *Journal of Business and Psychology*, *23*, 51-61. doi:10.1007/s10869-008-9075-z
- Byrne, B. M. (2013). *Structural equation modeling with AMOS: Basic concepts, applications, and programming* (2nd ed.). New York, NY: Routledge.
- Byrne, Z. S., & Cropanzano, R. (2001). *The history of organizational justice: The founders speak justice in the workplace* (Vol. 2, pp. 3-26). New York, NY: Psychology Press.
- Caputo, P. M. (2007). *Determinants and outcomes of performance appraisal fairness: An investigation of self-appraisal and rating format and groups* (Doctoral dissertation). Available from ProQuest Dissertations & Theses Full Text database. (UMI No. 549591915)
- Carlson, K. D., & Wu, J. (2011). The illusion of statistical control: Control variable practice in management research. *Organizational Research Methods*, *15*, 413-435. doi:1094428111428817
- Cascio, W. F. (1995). Whither industrial and organizational psychology in a changing world of work? *American Psychologist*, *50*, 928-939. doi:10.1037/0003-066X.50.11.928
- Cascio, W. F. (2000). Managing a virtual workplace. *Academy of Management Executive*, *14*(3), 81-90.

- Cawley, B. D., Keeping, L. M., & Levy, P. E. (1998). Participation in the performance appraisal process and employee reactions: A meta-analytic review of field investigations. *Journal of Applied Psychology, 83*, 615-633. doi:10.1037/0021-9010.83.4.615
- Coens, T., & Jenkins, M. (2002). *Abolishing performance appraisals: Why they backfire and what to do instead*. New York, NY: Berrett-Koehler.
- Cohen, J., Cohen, P., West, S. G., & Aiken, L. S. (2013). *Applied multiple regression/correlation analysis for the behavioral sciences* (3rd ed.). New York, NY: Routledge.
- Colquitt, J. A. (2001). On the dimensionality of organizational justice: A construct validation of a measure. *Journal of Applied Psychology, 86*, 386-400. doi:10.1037/0021-9010.86.3.386
- Colquitt, J. A., Conlon, D. E., Wesson, M. J., Porter, C. O., & Ng, K. Y. (2001). Justice at the millennium: A meta-analytic review of 25 years of organizational justice research. *Journal of Applied Psychology, 86*, 425-445. doi:10.1037//0021-9010.86.3.425
- Colquitt, J. A., Greenberg, J., & Zapata-Phelan, C. P. (2005). What is organizational justice? A historical overview. In J. Greenberg & J. Colquitt (Eds.), *Handbook of organizational justice* (pp. 3-56). Mahwah, NJ: Erlbaum.
- Colquitt, J. A., Lepine, J. A., & Wesson, M. J. (2009). *Organizational behavior: Improving performance and commitment in the workplace*. New York, NY: McGraw-Hill/Irwin.
- Cook, J., & Crossman, A. (2004). Satisfaction with performance appraisal systems: A study of role perceptions. *Journal of Managerial Psychology, 19*, 526-541.  
doi:10.1108/02683940410543605
- Cropanzano, R., Prehar, C. A., & Chen, P. Y. (2002). Using social exchange theory to distinguish procedural from interactional justice. *Group & Organization Management, 27*, 324-351.

- Culbert, S. (2010). Annual job review is 'total baloney', expert says. *National Public Radio*. Retrieved from <http://www.npr.org/templates/story/story.php?storyId=128362511>
- Cunningham, L. (2015, July 21). In big move, Accenture will get rid of annual performance reviews and rankings. *Washington Post*. Retrieved from <https://www.washingtonpost.com>
- Daft, R. L., & Lengel, R. H. (1986). Organizational information requirements, media richness and structural design. *Management Science*, *32*, 554-571.
- Dansereau, F., Jr., Graen, G., & Haga, W. J. (1975). A vertical dyad linkage approach to leadership within formal organizations: A longitudinal investigation of the role making process. *Organizational Behavior & Human Performance*, *13*, 46-78.
- Day, D., & Miscenko, D. (2015). Leader-member exchange (LMX): Construct evolution, contributions, and future prospects for advancing leadership theory. In T. Bauer & B. Erdogan (Eds.), *The Oxford handbook of leader-member exchange* (pp. 9-28). New York, NY: Oxford University Press.
- Decramer, A., Smolders, C., & Vanderstraeten, A. (2013). Employee performance management culture and system features in higher education: Relationship with employee performance management satisfaction. *International Journal of Human Resource Management*, *24*, 352-371. doi:10.1080/09585192.2012.680602
- DeNisi, A. S., & Pritchard, R. D. (2006). Performance appraisal, performance management and improving individual performance: A motivational framework. *Management and Organization Review*, *2*, 253-277.



- Dennis, A. R., & Kinney, S. T. (1998). Testing media richness theory in the new media: The effects of cues, feedback, and task equivocality. *Information Systems Research, 9*, 256-274.
- Dienesch, R., & Liden, R. (1986). Leader-member exchange model of leadership: A critique and further development. *Academy of management Review, 11*, 618-634.  
doi:10.5465/AMR.1986.4306242
- Duarte, N. T., Goodson, J. R., & Klich, N. R. (1993). How do I like thee? Let me appraise the ways. *Journal of Organizational Behavior, 14*, 239-249.
- Duarte, N. T., Goodson, J. R., & Klich, N. R. (1994). Effects of dyadic quality and duration on performance appraisal. *Academy of Management Journal, 37*, 499-521.  
doi:10.2307/256698
- Dunegan, K. J., Uhl-Bien, M., & Duchon, D. (2002). LMX and subordinate performance: The moderating effects of task characteristics. *Journal of Business and Psychology, 17*, 275-285.
- Dusterhoff, C., Cunningham, J. B., & MacGregor, J. N. (2014). The effects of performance rating, leader–member exchange, perceived utility, and organizational justice on performance appraisal satisfaction: Applying a moral judgment perspective. *Journal of Business Ethics, 119*, 265-273. doi:10.1007/s10551-013-1634-1
- Egan, T. M. (2011). Key intersections between HRD and management. *Human Resource Development Quarterly, 22*, 223-234. doi:10.1002/hrdq.20075
- Erdogan, B. (2002). Antecedents and consequences of justice perceptions in performance appraisals. *Human Resource Management Review, 12*, 555-578. doi:10.1016/S1053-4822(02)00070-0

- Farr, J. L., Baytalskay, N., & Johnson, J. E. (2015). Not everyone is above average: Providing feedback in formal job performance evaluations. In R. M. Sutton, M. J. Hornsey, & K. M. Douglas (Eds.), *Feedback: The communication of praise, criticism, and advice* (Vol. 11, pp. 201-215). New York, NY: Peter Lang.
- Fatima, T., Khan, M. B., & Khalili, T. (2015). Leader-member exchange quality and employee work behaviours: Mediating role of interactional justice. *European Journal of Business and Management*, 7(24), 1-9.
- Feldman, J. M. (1981). Beyond attribution theory: Cognitive processes in performance appraisal. *Journal of Applied Psychology*, 66, 127-148.
- Ferris, G. R., Munyon, T. P., Basik, K., & Buckley, M. R. (2008). The performance evaluation context: Social, emotional, cognitive, political, and relationship components. *Human Resource Management Review*, 18, 146-163. doi:10.1016/j.hrmr.2008.07.006
- Fix, B., & Sias, P. M. (2006). Person-centered communication, leader-member exchange, and employee job satisfaction. *Communication Research Reports*, 23, 35-44.  
doi:10.1080/17464090500535855
- Fletcher, C., & Williams, R. (1996). Performance management, job satisfaction and organizational commitment. *British Journal of Management*, 7, 169-179.
- Folger, R., & Cropanzano, R. (1998). *Organizational justice and human resource management*. Thousand Oaks, CA: Sage.
- Folger, R., & Konovsky, M. (1989). Effects of procedural and distributive justice on reactions to pay raise decisions. *Academy of Management Journal*, 32, 115-130. doi:10.2307/256422
- Folger, R., Konovsky, M., & Cropanzano, R. (1992). A due-process metaphor for performance appraisal. *Research in Organizational Behavior*, 14, 129-177.

- Foster, T. C. (2006). *Analysis of organizational justice as a framework for understanding the impact of performance appraisal systems on judicial outcomes in wrongful discharge cases* (Doctoral dissertation). Available from ProQuest Dissertations & Theses Full Text database. (UMI No. 3212132)
- Gajendran, R. S., & Harrison, D. A. (2007). The good, the bad, and the unknown about telecommuting: Meta-analysis of psychological mediators and individual consequences. *Journal of Applied Psychology, 92*, 1524-1541. doi:10.1037/0021-9010.92.6.1524
- George, D., & Mallery, P. (2010). *SPSS for Windows step by step: A simple guide and reference, 18.0 update* (11th ed.). Boston, MA: Allyn and Bacon.
- Gerstner, C. R., & Day, D. V. (1997). Meta-analytic review of leader–member exchange theory: Correlates and construct issues. *Journal of Applied Psychology, 82*, 827-844. doi:10.1037/0021-9010.82.6.827
- Giles, W. F., & Mossholder, K. W. (1990). Employee reactions to contextual and session components of performance appraisal. *Journal of Applied Psychology, 75*, 371-377. doi:10.1037/0021-9010.75.4.371
- Gilley, J. W., Boughton, N. W., & Maycunich, A. (1999). *The performance challenge: Developing management systems to make employees your organization's greatest asset*. Cambridge, MA: Perseus Books.
- Gilley, J. W., Egglund, S. A., & Gilley, A. M. (2002). *Principles of human resource development*. New York, NY: Basic Books.
- Gilley, J. W., & Gilley, A. M. (2002). *Strategically integrated HRD: Six transformational roles in creating results-driven programs*. New York, NY: Basic Books.

- Gilliland, W., & Hale, M. S. (2005). How can justice be used to improve employee selection practices. In J. Greenberg & J. Colquitt (Eds.), *Handbook of organizational justice* (pp. 411-438). Mahwah, NJ: Erlbaum.
- Glover, R. B. (1996). Why are we ignoring performance appraisal research? *Parks & Recreation*, *31*, 11-15.
- Golden, T. D., Barnes-Farrell, J. L., & Mascharka, P. B. (2009). Implications of virtual management for subordinate performance appraisals: A pair of simulation studies. *Journal of Applied Social Psychology*, *39*, 1589-1608. doi:10.1111/j.1559-1816.2009.00496.x
- Golden, T. D., & Veiga, J. F. (2005). The impact of extent of telecommuting on job satisfaction: Resolving inconsistent findings. *Journal of Management*, *31*, 301-318.  
doi:10.1177/0149206304271768
- Golden, T. D., & Veiga, J. F. (2008). The impact of superior-subordinate relationships on the commitment, job satisfaction, and performance of virtual workers. *Leadership Quarterly*, *19*, 77-88. doi:10.1016/j.leaqua.2007.12.009
- Gordon, M. E., & Stewart, L. P. (2009). Conversing about performance: Discursive resources for the appraisal interview. *Management Communication Quarterly*, *22*, 473-501.  
doi:10.1177/0893318908327159
- Graen, G. B., & Scandura, T. A. (1987). Toward a psychology of dyadic organizing. *Research in Organizational Behavior*, *9*, 175-208.
- Graen, G. B., & Uhl-Bien, M. (1995). Relationship-based approach to leadership: Development of leader-member exchange (LMX) theory of leadership over 25 years: Applying a multi-

- level multi-domain perspective. *Leadership Quarterly*, 6, 219-247. doi:10.1016/1048-9843(95)90036-5
- Graham, J. M., Guthrie, A. C., & Thompson, B. (2003). Consequences of not interpreting structure coefficients in published CFA research: A reminder. *Structural Equation Modeling*, 10, 142-153.
- Greenberg, J. (1990). Organizational justice: Yesterday, today, and tomorrow. *Journal of Management*, 16, 399-432.
- Greenberg, J. (1993). The social side of fairness: Interpersonal and informational classes of organizational justice. In R. Cropanzano (Ed.), *Justice in the workplace: Approaching fairness in human resource management* (pp. 79-103). Erlbaum: Hillsdale, NJ.
- Grote, D. (2000). Performance appraisal reappraised. *Harvard Business Review*, 78, 21.
- Grote, D. (2011). *How to be good at performance appraisal: Simple, effective, done right*. Boston, MA: Harvard Business Review Press.
- Gruman, J. A., & Saks, A. M. (2011). Performance management and employee engagement. *Human Resource Management Review*, 21, 123-136. doi:10.1016/j.hrmr.2010.09.004
- Hakonen, M., & Lipponen, J. (2008). Procedural justice and identification with virtual teams: The moderating role of face-to-face meetings and geographical dispersion. *Social Justice Research*, 21, 164-178. doi:10.1007/s11211-008-0070-3
- Harpaz, I. (2002). Advantages and disadvantages of telecommuting for the individual, organization and society. *Work Study*, 51(2), 74-80. doi:10.1108/00438020210418791
- Hayes, A. F. (2013). *Introduction to mediation, moderation, and conditional process analysis: A regression-based approach*. New York, NY: Guilford Press.

- Hertel, G., Geister, S., & Konradt, U. (2005). Managing virtual teams: A review of current empirical research. *Human Resource Management Review, 15*, 69-95.  
doi:10.1016/j.hrmr.2005.01.002
- Hickman, S. (2001). *How to conduct a performance appraisal*. Alexandria, VA: American Society for Training and Development.
- Hu, L. T., & Bentler, P. M. (1999). Cutoff criteria for fit indexes in covariance structure analysis: Conventional criteria versus new alternatives. *Structural Equation Modeling, 6*, 1-55.
- Ilggen, D. R., Barnes-Farrell, J. L., & McKellin, D. B. (1993). Performance appraisal process research in the 1980s: What has it contributed to appraisals in use? *Organizational Behavior and Human Decision Processes, 54*, 321-368. doi:10.1006/obhd.1993.1015
- Ilies, R., Morgeson, F. P., & Nahrgang, J. D. (2005). Authentic leadership and eudaemonic well-being: Understanding leader–follower outcomes. *Leadership Quarterly, 16*, 373-394.  
doi:10.1016/j.leaqua.2005.03.002
- Iqbal, M. Z., Akbar, S., & Budhwar, P. (2014). Effectiveness of performance appraisal: An integrated framework. *International Journal of Management Reviews, 17*, 510-533.  
doi:10.1111/ijmr.12050
- Javad, S., & S.D, S. (2015). It's time to bring performance appraisal into the twenty-first century. *Human Resource Management International Digest, 23*(7), 23-26. doi:10.1108/HRMID-07-2015-0127
- Jawahar, I. (2007). The influence of perceptions of fairness on performance appraisal reactions. *Journal of Labor Research, 28*, 735-754. doi:10.1007/s12122-007-9014-1

- Johnson, D. R., & Borden, L. A. (2012 ). Participants at your fingertips using Amazon's Mechanical Turk to increase student–faculty collaborative research. *Teaching of Psychology, 39*(4), 245-251.
- Judge, T. A., & Ferris, G. R. (1993). Social context of performance evaluation decisions. *Academy of Management Journal, 36*, 80-105.
- Kacmar, K. M., Witt, L. A., Zivnuska, S., & Gully, S. M. (2003). The interactive effect of leader-member exchange and communication frequency on performance ratings. *Journal of Applied Psychology, 88*, 764-772. doi:10.1037/002-9010.88.4.764
- Kanawattanachai, P., & Yoo, Y. (2002). Dynamic nature of trust in virtual teams. *Journal of Strategic Information Systems, 11*, 187-213. doi:10.1016/S0963-8687(02)00019-7
- Kass, E. (2008). Interactional justice, negotiator outcome satisfaction, and desire for future negotiations: R-E-S-P-E-C-T at the negotiating table. *International Journal of Conflict Management, 19*, 319-338. doi:10.1108/10444060810909284
- Keeping, L. M., & Levy, P. E. (2000). Performance appraisal reactions: Measurement, modeling, and method bias. *Journal of Applied Psychology, 85*, 708-723. doi:10.1037/0021-9010.85.5.708
- Kim, S. E., & Rubianty, D. (2011). Perceived fairness of performance appraisals in the federal government: Does it matter? *Review of Public Personnel Administration, 31*, 329-348. doi:10.177/0734371X11428903
- Kim, T., & Holzer, M. (2014). Public employees and performance appraisal: A study of antecedents to employees' perception of the process. *Review of Public Personnel Administration, 36*, 31-56. doi:10.1177/0734371x14549673

- Kline, R. B. (2005). *Principles and practice of structural equation modeling: Methodology in the social sciences*. New York, NY: Guilford Press.
- Kline, T. J., & Sulsky, L. M. (2009). Measurement and assessment issues in performance appraisal. *Canadian Psychology/Psychologie canadienne*, 50(3), 161-171.  
doi:10.1037/a00015668
- Knowles, M. S., Holton III, E. F., & Swanson, R. A. (2014). *The adult learner: The definitive classic in adult education and human resource development*. New York, NY: Routledge.
- Kondrasuk, J. N. (2012). The ideal performance appraisal is a format, not a form. *Academy of Strategic Management Journal*, 11, 115-130.
- Korsgaard, M. A., & Roberson, L. (1995). Procedural justice in performance evaluation: The role of instrumental and non-instrumental voice in performance appraisal discussions. *Journal of Management*, 21, 657-669.
- Korsgaard, M. A., Sapienza, H. J., & Schwieger, D. M. (2001). Justice in the workplace. In R. Cropanzano (Ed.), *Justice in the workplace* (Vol. 2, pp. 209-226). New York, NY: Psychology Press.
- Kraut, R. E., Fussell, S. R., Brennan, S. E., & Siegel, J. (2002). Understanding effects of proximity on collaboration: Implications for technologies to support remote collaborative work. In P. J. Hinds & S. Kiesler (Eds.), *Distributed work* (pp. 137-162). Cambridge, MA: MIT Press.
- Kurland, N. B., & Cooper, C. D. (2002). Manager control and employee isolation in telecommuting environments. *Journal of High Technology Management Research*, 13, 107-126.



- Kurtzberg, T. R., Naquin, C. E., & Belkin, L. Y. (2006). Electronic performance appraisals: The effects of e-mail communication on peer ratings in actual and simulated environments. *Organizational Behavior & Human Decision Processes*, 98, 216-226.  
doi:10.1016/j.obhdp.2005.07.001
- Kuvaas, B. (2011). The interactive role of performance appraisal reactions and regular feedback. *Journal of Managerial Psychology*, 26, 123-137. doi:10.1108/02683941111102164
- Landy, F. J., & Farr, J. L. (1980). Performance rating. *Psychological Bulletin*, 87, 72-107.  
doi:10.1037/0033290987.1.72
- Lau, W. K. (2014). Employee's participation: A critical success factor for justice perception under different leadership styles. *Journal of Management Policies and Practices*, 2(4), 53-76. doi:10.15640/jmpp.v2n4a3
- Leung, K., Su, S., & Morris, M. W. (2001). When is criticism not constructive? The roles of fairness perceptions and dispositional attributions in employee acceptance of critical supervisory feedback. *Human Relations*, 54, 1155-1187. doi:10.1177/0018726701549002
- Leventhal, G. S. (1980). What should be done with equity theory? New approaches to the study of justice in social relationships. *Social Exchange: Advances in Experimental and Social Psychology*, 9, 91-113.
- Levy, P. E., & Thompson, D., J. (2015). Feedback in organizations: Individual differences and the social context. In R. M. Sutton, M. J. Hornsey, & K. M. Douglas (Eds.), *Feedback: The communication of praise, criticism, and advice* (Vol. 11, pp. 217-231). New York, NY: Peter Lang.

- Levy, P. E., & Williams, J. R. (2004). The social context of performance appraisal: A review and framework for the future. *Journal of Management*, *30*, 881-905.  
doi:10.1016/j.jm.2004.06.005
- Liao, H., & Rupp, D. E. (2005). The impact of justice climate and justice orientation on work outcomes: A cross-level multifoci framework. *Journal of Applied Psychology*, *90*, 242.
- Liden, R., & Graen, G. (1980). Generalizability of the vertical dyad linkage model of leadership. *Academy of Management Journal*, *23*, 451-465. doi:10.2307/255511
- Liden, R., & Maslyn, J. (1998). Multidimensionality of leader-member exchange: An empirical assessment through scale development. *Journal of Management*, *24*, 43-72.  
doi:10.1016/S0149-2063(99)80053-1
- Liden, R., Sparrowe, R., & Wayne, S. (1997). Leader-member exchange theory: The past and potential for the future. In G. R. Ferris & G. R. Ferris (Eds.), *Research in personnel and human resources management* (Vol. 15, pp. 47-119). New York, NY: Elsevier Science/JAI Press.
- Lin, X. (2015). How does procedural justice climate influence individual outcomes? An effective perspective. *Asia Pacific Journal of Management*, *32*, 771-800. doi:10.1007/s10490-015-9421-4
- Lind, E. A., & Tyler, T. R. (1988). *The social psychology of procedural justice*. New York: Plenum Press.
- London, M., & Smither, J. W. (2002). Feedback orientation, feedback culture, and the longitudinal performance management process. *Human Resource Management Review*, *12*, 81-100.

- Longenecker, C. O., & Nykodym, N. (1996). Public sector performance appraisal effectiveness: A case study. *Public Personnel Management*, 25, 151-163.
- Lundquist, K. K. (2014). *A primer on performance management*. Paper presented at the American Bar Association Section of Labor & Employment Law, 8th Annual Labor & Employment Law Conference, Los Angeles, CA.
- MacDuffie, J. P. (2007). HRM and distributed work: Managing people across distances. *Academy of Management Annals*, 1, 549-615. doi:10.1080/078559817
- Masterson, S., & Lenses, M. (2015). Leader-member exchange and justice. In T. Bauer & B. Erdogan (Eds.), *The Oxford handbook of leader-member exchange* (pp. 67-84). New York, NY: Oxford University Press.
- Maurer, R. (2015). How HR can prepare for the future of work. Retrieved from <http://www.shrm.org/hrdisciplines/staffingmanagement/articles/pages/how-hr-can-prepare-future-work.aspx>
- McAllister, D. J. (1995). Affect- and cognition-based trust as foundations for interpersonal cooperation in organizations. *Academy of Management Journal*, 38, 24-59.
- McFarlin, D. B., & Sweeney, P. D. (1992). Research notes. Distributive and procedural justice as predictors of satisfaction with personal and organizational outcomes. *Academy of Management Journal*, 35, 626-637.
- Milkovich, G. T., & Boudreau, J. W. (1997). *Personnel/human resource management: A diagnostic approach*. Homewood, IL: Richard Irwin.
- Mitchell, M., & Jolley, J. (2001). *Research design explained* (4th ed.). New York, NY: Harcourt.
- Morris, D. (2014, May 29). Why businesses should rethink the annual performance review. *Forbes*. Retrieved from <http://www.forbes.com>

- Murphy, K. R., & Cleveland, J. (1995). *Understanding performance appraisal: Social, organizational, and goal-based perspectives*. Thousand Oaks, CA: Sage.
- Nanterme, P. (2015, July 23). Accenture CEO explains why he's overhauling performance reviews. *Washington Post*. Retrieved from <https://www.washingtonpost.com>
- Nathan, B. R., Mohrman, A. M., & Milliman, J. (1991). Interpersonal relations as a context for the effects of appraisal interviews on performance and satisfaction: A longitudinal study. *Academy of Management Journal*, 34, 352-369. doi:10.2307/256446
- Neergaard, H., & Ulhøi, J. P. (2007). *Handbook of qualitative research methods in entrepreneurship*. New York, NY: Edward Elgar Publishing.
- Nimon, K. F., & Astakhova, M. (2015). Improving the rigor of quantitative HRD research: Four recommendations in support of the general hierarchy of evidence. *Human Resource Development Quarterly*. doi:10.1002/hrdq.21219
- Panggabean, M. S. (2001). *Impact of perceived justice in performance appraisal on work attitudes and performance* (Doctoral dissertation). Available from ProQuest Dissertations & Theses Full Text database. (UMI No. 276059929)
- Pettijohn, C. E., Pettijohn, L. S., & D'Amico, M. (2001). Characteristics of performance appraisals and their impact on sales force satisfaction. *Human Resource Development Quarterly*, 12, 127-146. doi:10.1002/hrdq.4
- Pichler, S. (2009). *Employee reactions to performance appraisal: Development of an integrative framework and meta-analysis* (Doctoral dissertation). Available from ProQuest Dissertations & Theses Global database. (UMI No. 3381318)
- Pichler, S. (2012). The social context of performance appraisal and appraisal reactions: A meta-analysis. *Human Resource Management*, 51, 709-732. doi:10.1002/hrm.21499

- Pichler, S., Varma, A., Michel, J. S., Levy, P. E., Budhwar, P. S., & Sharma, A. (2015). Leader-member exchange, group- and individual-level procedural justice and reactions to performance appraisals. *Human Resource Management, 55*, 871-883.  
doi:10.1002/hrm.21724
- Podsakoff, P. M., MacKenzie, S. B., Lee, J. Y., & Podsakoff, N. P. (2003). Common method biases in behavioral research: A critical review of the literature and recommended remedies. *Journal of Applied Psychology, 88*, 879-903. doi:10.1037/0021-9010.88.5.879
- Pooyan, A., & Eberhardt, B. J. (1989). Correlates of performance appraisal satisfaction among supervisory and nonsupervisory employees. *Journal of Business Research, 19*, 215-226.
- Posthuma, R. A., & Campion, M. A. (2008). Twenty best practices for just employee performance reviews employers can use a model to achieve performance reviews that increase employee satisfaction, reduce the likelihood of litigation and boost motivation. *Compensation & Benefits Review, 40*, 47-55. doi:10.1177/0886368707312139
- Potter, R. E., & Balthazard, P. A. (2002). Virtual team interaction styles: Assessment and effects. *International Journal of Human-Computer Studies, 56*, 423-443. doi:10.1006/ihc.1001
- Pulakos, E., Hanson, R. M., Arad, S., & Moye, N. (2015). Performance management can be fixed: An on-the-job experiential learning approach for complex behavior change. *Industrial & Organizational Psychology, 8*, 51-76. doi:10.1017/iop.2014.2
- Pulakos, E., Mueller-Hanson, R., O'Leary, R., & Meyrowitz, M. (2012). *Building a high-performance culture: A fresh look at performance management*. Alexandria, VA: Society for Human Resource Management Foundation.
- Pulakos, E., & O'Leary, R. (2011). Why is performance management broken? *Industrial & Organizational Psychology, 4*, 146-164. doi:10.1111/j.1754-9434.2011.01315.x

- Purvanova, R. K. (2014). Face-to-face versus virtual teams: What have we really learned? *Psychologist-Manager Journal, 17*, 2-29. doi:10.1037/mgr0000009
- Roberts, G. E. (1992). Linkages between performance appraisal system effectiveness and rater and ratee acceptance. *Review of Public Personnel Administration, 12*(3), 19-41. doi:10.1177/0734371X9201200303
- Rockmann, K., & Pratt, M. (2015). Contagious offsite work and the lonely office? The unintended consequences of distributed work. *Academy of Management Discoveries, 1*, 150-164. doi:10.5465/amd.2014.0016
- Russ, G. S., Daft, R. L., & Lengel, R. H. (1990). Media selection and managerial characteristics in organizational communications. *Management Communication Quarterly, 4*, 151-175. doi:10.1177/0893318990004002002
- Saal, F. E., Downey, R. G., & Lahey, M. A. (1980). Rating the ratings: Assessing the psychometric quality of rating data. *Psychological Bulletin, 88*, 413-428. doi:10.1037/0033-2909.88.2.413
- Saks, A. M., & Gruman, J. A. (2011). Manage employee engagement to manage performance. *Industrial & Organizational Psychology, 4*, 204-207. doi:10.1111/j.1754-9434.2011.01328.x
- Schminke, M., Ambrose, M. L., & Cropanzano, R. S. (2000). The effect of organizational structure on perceptions of procedural fairness. *Journal of Applied Psychology, 85*, 294-304. doi:10.1037/0021-9010.85.2.294
- Schumacker, R. E., & Lomax, R. G. (2010). *A beginner's guide to structural equation modeling* (3rd ed.). New York, NY: Routledge.

- Shahmehar, F. S., Safari, N., Jamshidi, M. J., & Yaghoobi, N. M. (2014). The impact of performance management on mission statement and operational goal setting. *International Journal of Business and Management*, 9(11), 10. doi:10.5539/ijbm.v9n11p189
- Skarlicki, D. P., Ellard, J. H., & Kelln, B. R. (1998). Third-party perceptions of a layoff: Procedural, derogation, and retributive aspects of justice. *Journal of Applied Psychology*, 83, 119. doi:10.1037/0021-9010.83.1.119
- Spence, J., & Keeping, L. (2010). The impact of non-performance information on ratings of job performance: A policy-capturing approach. *Journal of Organizational Behavior*, 31, 587-608. doi:10.1002/job.648
- Spence, J., & Keeping, L. (2011). Conscious rating distortion in performance appraisal: A review, commentary, and proposed framework for research. *Human Resource Management Review*, 21(2), 85-95. doi:10.1016/j.hrmr.2010.09.013
- Steelman, L. A., Levy, P. E., & Snell, A. F. (2004). The feedback environment scale: Construct definition, measurement, and validation. *Educational and Psychological Measurement*, 64, 165. doi:10.1177/0013164403258440
- Stevens, J. P. (2009). *Applied multivariate statistics for the social sciences* (5th ed.). Mahwah, NJ: Routledge Academic.
- Swanson, R. A., & Arnold, D. E. (1996). Part one: What is the purpose of human resource development? The purpose of human resource development is to improve organizational performance. *New Directions for Adult and Continuing Education*, 1996, 13-19.
- Tabachnick, B. G., & Fidell, L. S. (2012). *Using multivariate statistics* (6th ed.). Boston, MA: Pearson Education.

- Taris, T. W., & Schreurs, P. J. G. (2009). Well-being and organizational performance: An organizational-level test of the happy-productive worker hypothesis. *Work & Stress, 23*, 120-136. doi:10.1080/02678370903072555
- Taylor, M. S., Masterson, S. S., Renard, M. K., & Tracy, K. B. (1998). Managers' reactions to procedurally just performance management systems. *Academy of Management Journal, 41*, 568-579. doi:10.2307/256943
- Taylor, M. S., Tracy, K. B., Renard, M. K., Harrison, J. K., & Carroll, S. J. (1995). Due process in performance appraisal: A quasi-experiment in procedural justice. *Administrative Science Quarterly, 40*, 495-523.
- Thibaut, J. W., & Walker, L. (1975). *Procedural justice: A psychological analysis*. Hillsdale, NJ: Erlbaum.
- Thomas, S., & Bretz, R. (1994). Research and practice in performance appraisal: Evaluating employee performance in America's largest companies. *SAM Advanced Management Journal, 59*(2), 28-34.
- Thurston, P. W. (2001). *Clarifying the structure of justice using fairness perceptions of performance appraisal practices* (Doctoral dissertation). Available at ProQuest Dissertations & Theses Full Text database. (UMI No 3038781)
- Towers Watson. (2012). *2012 Global Workforce Study—Engagement at risk: Driving strong performance in a volatile global environment*. Arlington, VA: Author.
- Turgut, H., & Mert, I. S. (2014). Evaluation of performance appraisal methods through appraisal errors by using fuzzy VIKOR method. *International Business Research, 7*(10), 170-178. doi:10.5539/ibr.v7n10p170



- Tziner, A., Joanis, C., & Murphy, K. R. (2000). A comparison of three methods of performance appraisal with regard to goal properties, goal perception, and ratee satisfaction. *Group & Organization Management, 25*, 175-190.
- Tziner, A., Shultz, T., & Fisher, T. (2008). Justice, leader-member exchange, and job performance: Are their relationships mediated by organizational culture? *Psychological Reports, 103*, 516-526. doi:10.2466/PRO.103.2.516-526
- Umlauft, S., & Dalbert, C. (2012). Feedback: A justice motive perspective. In R. M. Sutton, M. J. Hornsey, & K. M. Douglas (Eds.), *Feedback: The communication of praise, criticism and advice* (pp. 57-71). New York, NY: Peter Lang.
- U.S. Census Bureau. (2012). *Home-based workers in the United States, 2010: Household economic studies*. Retrieved from <https://www.census.gov/prod/2012pubs/p70-132.pdf>
- U.S. Department of Labor. (2015). *Workforce statistics: Finance and insurance sector: Employment, unemployment, and openings, hires, and separations*. Retrieved from <http://www.bls.gov/iag/tgs/iag52.htm#workforce>
- Wang, G. G., & Swanson, R. A. (2008). The idea of national HRD: An analysis based on economics and theory development methodology. *Human Resource Development Review, 7*, 79-106. doi:10.1177/1534484307311415
- Watson-Manheim, M. B., Chudoba, K. M., & Crowston, K. (2002). Discontinuities and continuities: A new way to understand virtual work. *Information Technology & People, 15*, 191-209. doi:10.1108/09593840410570258
- Wayne, S. J., Shore, L. M., Bommer, W. H., & Tetrick, L. E. (2002). The role of fair treatment and rewards in perceptions of organizational support and leader-member exchange. *Journal of Applied Psychology, 87*, 590-598. doi:10.1037//0021-9010.87.3.590

- Wayne, S., & Liden, R. (1995). Effects on impression management on performance ratings: A longitudinal study. *Academy of Management Journal*, 38, 232-260. doi:10.2307/256734
- Wayne, S., Shore, L., & Liden, R. (1997). Perceived organizational support and leader-member exchange: A social exchange perspective. *Academy of Management Journal*, 40, 82-111. doi:10.2307/257021
- Westerman, C. Y. K., Heuett, K. B., Reno, K. M., & Curry, R. (2014). What makes performance feedback seem just? Synchronicity, channel, and valence effects on perceptions of organizational justice in feedback delivery. *Management Communication Quarterly*, 28, 244-263. doi:10.1177/0893318914524060
- Wexley, K., & Pulakos, E. (1982). Sex effects on performance ratings on manager-subordinate dyads: A field study. *Journal of Applied Psychology*, 67, 433-439. doi:10.1037/0021-9010.67.4.433
- Wilson, R. (2011). *Fairness in feedback: Effects of justice in performance appraisal* (Doctoral dissertation). Available from ProQuest Dissertations & Theses Full Text database. (UMI No. 3471034)
- Wilson, T., Wells, S., Little, H., & Ross, M. (2014). A history of internal control: From then to now. *Academy of Business Journal*, 1, 73-89.
- Wittmer, J., Martin, J., & Tekleab, A. (2010). Procedural justice and work outcomes in a unionized setting: The mediating role of leader-member exchange. *American Journal of Business*, 25(2), 55.

## Appendix A: Permission to Use Performance Appraisal Satisfaction Scale

On Nov 24, 2015, at 1:42 PM, [bcunning@uvic.ca](mailto:bcunning@uvic.ca) wrote:

Hi Debra

They are correct. I did not read your email closely and I thought you wanted other items. And, you have our permission to use the satisfaction scale...

Bart

On Nov 24, 2015 at 11:19 AM, [landin.herd@gmail.com](mailto:landin.herd@gmail.com) wrote:

Thank you Dr. Cunningham -

I appreciate your reply and the identification of the justice items in the question list of your paper.

From the paper, the items I listed in my email request reflect the performance appraisal satisfaction questions. I used them in 2014 for a statistics class after Dr. MacGregor confirmed them. If these are not correct, please advise.

Thank you again and I wish you the very best,

On Nov 23, 2015, at 5:21 PM, [bcunning@uvic.ca](mailto:bcunning@uvic.ca) wrote:

Hi Debra

Here is the survey.

Justice is defined as Justice - #2 + #5 + #6 + #14 + #11 + #12 + #15.

The other measures are defined in the paper, I think.

Bart

On Nov 22, 2015, at 10:55 PM, Debra Herd <[dherd@patriots.utttyler.edu](mailto:dherd@patriots.utttyler.edu)> wrote:

**From:** Debra Herd

**Sent:** Sunday, November 22, 2015 9:58 PM

**To:** [jmacgreg@uvic.ca](mailto:jmacgreg@uvic.ca); [bcunning@uvic.ca](mailto:bcunning@uvic.ca)

**Subject:** Request Permission to Use Performance Appraisal Satisfaction Scale - D Herd UTT PhD Candidate

### REQUEST FOR PERMISSION TO USE PERFORMANCE APPRAISAL SATISFACTION SCALE

To:

Jim MacGregor, PhD - University of Victoria, [jmacgreg@uvic.ca](mailto:jmacgreg@uvic.ca)

J. Barton Cunningham, PhD - University of Victoria, [bcunning@uvic.ca](mailto:bcunning@uvic.ca)

Hello -

My name is Debbie Herd. I am a PhD candidate at the University of TX at Tyler College of Business in the HR Development Program. I am preparing my doctoral dissertation proposal tentatively titled, "Performance Appraisal Satisfaction through the Lens of a Distributed Workplace Arrangement." I am using procedural justice, leader-member exchange and media richness theory constructs on performance appraisal satisfaction.

I am writing to you to request your permission to use the **performance appraisal satisfaction** scale from the following article – Dusterhoff, C., Cunningham, J. B., & MacGregor, J. N. (2014). The effects of performance rating, leader-member exchange, perceived utility, and organizational justice on performance appraisal satisfaction: Applying a moral judgment perspective. *Journal of Business Ethics*, 119(2), 265-273. doi:10.1007/s10551-013-1634-1

#### Items:

- I felt satisfied with the performance review session
- Overall I felt that the performance review process (including the planning and focusing phases) was valuable
- I have positive expectations of future performance review meetings
- I agreed with my performance review result

Response Anchors:

1. Strongly disagree
2. Disagree
3. Neutral
4. Agree
5. Strongly agree

Please let me know if you have any questions. I can be reached at [dherd@patriots.utt Tyler.edu](mailto:dherd@patriots.utt Tyler.edu) or at 214 998 1919. My dissertation chair is Dr. Ann Gilley. She can be reached at [agilley@utt Tyler.edu](mailto:agilley@utt Tyler.edu) should you have any questions.

Thank you in advance for the consideration. Your prompt reply would be very much appreciated.

Regards,

## Appendix B: Permission to Use Procedural Justice Scale

On Nov 23, 2015, at 7:56 AM, [colq@uga.edu](mailto:colq@uga.edu) replied:

Hi Debbie,

No permission is needed, as that scale is published in the public domain. That said, permission granted.

Best,

Jason

On Nov 22, 2015, at 10:58 PM, Debra Herd <[dherd@patriots.utttyler.edu](mailto:dherd@patriots.utttyler.edu)> wrote:

### REQUEST FOR PERMISSION TO USE PROCEDURAL JUSTICE SCALE

To: Jason A Colquitt, PhD - University of Georgia, [colq@uga.edu](mailto:colq@uga.edu)

Hello Dr. Colquitt - Hope all is well with you.

My name is Debbie Herd. I am a PhD candidate at the University of TX at Tyler College of Business in the HR Development Program. I am preparing my doctoral dissertation proposal tentatively titled, "Performance Appraisal Satisfaction through the Lens of a Distributed Workplace Arrangement." I am using procedural justice, leader-member exchange and media richness theory constructs on performance appraisal satisfaction.

I am writing to you to request your permission to use your **organizational justice** scale (specifically, the **procedural justice** scale) from the following article –

Colquitt, J. A. (2001). On the dimensionality of organizational justice: A construct validation of a measure. *Journal of Applied Psychology*, 86(3), 386-400. doi:10.1037/0021-9010.86.3.386

#### Items (modified to reflect performance appraisal topic):

1. Have you been able to express your views and feelings during performance appraisal procedures?
2. Have you had influence over the outcome arrived at by the performance appraisal procedures?
3. Have the performance appraisal procedures been applied consistently?
4. Have the performance appraisal procedures been free of bias?
5. Have the performance appraisal procedure's been based on accurate information?
6. Have you been able to appeal the outcome arrived at by performance appraisal procedures?
7. Have the performance appraisal procedures upheld ethical and moral standards?

#### Response Anchors:

1. To a Very Small Extent
2. To a Small Extent
3. To a Moderate Extent
4. To a Large Extent
5. To a Very Large Extent

Please let me know if you have any questions. I can be reached at [dherd@patriots.utttyler.edu](mailto:dherd@patriots.utttyler.edu) or at 214 998 1919. My dissertation chair is Dr. Ann Gilley. She can be reached at [agilley@utttyler.edu](mailto:agilley@utttyler.edu). Thank you in advance for the consideration. Your prompt reply would be very much appreciated.

Regards,

|||||  
Jason A. Colquitt, Ph.D.  
William Harry Willson Distinguished Chair  
Coordinator, [PhD Program in Management](#)  
Terry College of Business  
University of Georgia  
412 Brooks Hall  
Athens, GA 30602-6256  
Phone: (706) 542-3745  
Fax: (706) 542-3743  
E-mail: [colq@uga.edu](mailto:colq@uga.edu)  
|||||

## Appendix C: Permission to Use Leader-Member Exchange Scale

On Nov 23, 2015, at 5:58 AM, [mary.uhlbien@gmail.com](mailto:mary.uhlbien@gmail.com) via patriots.uttyler.edu replied:

It is a publicly available measure so you are free to use it.

All best,  
Mary

On Nov 22, 2015, at 10:58 PM, Debra Herd <[dherd@patriots.uttyler.edu](mailto:dherd@patriots.uttyler.edu)> wrote:

**From:** Debra Herd  
**Sent:** Sunday, November 22, 2015 9:58 PM  
**To:** [lmxlotus@aol.com](mailto:lmxlotus@aol.com); [m.uhl-bien@tcu.edu](mailto:m.uhl-bien@tcu.edu)  
**Subject:** Request Permission to Use LMX Scale - From D Herd, UTT PhD Candidate

### REQUEST FOR PERMISSION TO USE LMX SCALE

To:  
George B Graen, PhD - [lmxlotus@aol.com](mailto:lmxlotus@aol.com), and  
Mary Uhl-Bien, PhD - Texas Christian University, [m.uhl-bien@tcu.edu](mailto:m.uhl-bien@tcu.edu)

Hello -

My name is Debbie Herd. I am a PhD candidate at the University of TX at Tyler College of Business in the HR Development Program. I am preparing my doctoral dissertation proposal tentatively titled, "Performance Appraisal Satisfaction through the Lens of a Distributed Workplace Arrangement." I am using leader-member exchange, procedural justice, and media richness theory constructs on performance appraisal satisfaction.

I am writing to you to request your permission to use your **leader-member exchange** scale the following article –  
Graen, G. B., & Uhl-Bien, M. (1995). Relationship-based approach to leadership: Development of leader-member exchange (LMX) theory of leadership over 25 years: Applying a multi-level multi-domain perspective. *The Leadership Quarterly*, 6(2), 219-247. doi:10.1016/1048-9843(95)90036-5

#### Items and Related Response Anchors:

1. Do you know where you stand with your leader...do you usually know how satisfied your leader is with what you do?  
Rarely, Occasionally, Sometimes, Fairly Often, Very Often
2. How well does your leader understand your job problems and needs? Not a Bit, A Little, A Fair Amount, Quite a Bit, A Great Deal
3. How well does your leader recognize your potential? Not at All, A Little, Moderately, Mostly, Fully
4. Regardless of how much formal authority he/she has built into his/her position, what are the chances that your leader would use his/her power to help you solve your problems in your work? None, Small, Moderate, High, Very High
5. Again, regardless of the amount of formal authority your leader has, what are the chances that he/she would "bail you out" at his/her expense? (What are the chances that you would?) None, Small, Moderate, High, Very High
6. I have enough confidence in my leader that I would defend and justify his/her decision if he/she were not present to do so?  
Strongly Disagree, Disagree, Neutral, Agree, Strongly Agree
7. How would you characterize your working relationship with your leader? Extremely Ineffective, Worse Than Average, Average, Better Than Average, Extremely Effective

Please let me know if you have any questions. I can be reached at [dherd@patriots.uttyler.edu](mailto:dherd@patriots.uttyler.edu) or at 214 998 1919. My dissertation chair is Dr. Ann Gilley. She can be reached at [agilley@uttyler.edu](mailto:agilley@uttyler.edu).

Thank you in advance for the consideration. Your prompt reply would be very much appreciated.

Regards,

## Appendix D: Permission to Use Perceived Media Richness Scale

On Jan 7, 2016, at 10:05 PM, [ardennis@indiana.edu](mailto:ardennis@indiana.edu) via patriots.utttyler.edu replied:

Debbie

Sure. It is a published measure so you certainly don't need my permission but you have it.

Alan

On January 5, 2016, at 7:50pm PM, Debra Herd <[dherd@patriots.utttyler.edu](mailto:dherd@patriots.utttyler.edu)> wrote:

**From:** Debra Herd

**Sent:** Tue 1/5/2016 7:50 PM

**To:** [ardennis@indiana.edu](mailto:ardennis@indiana.edu);

**Subject:** Request for Permission to Use Perceived Media Richness Scale – From D Herd, UTT PhD Candidate

### REQUEST FOR PERMISSION TO USE PERCEIVED MEDIA RICHNESS SCALE

To: Alan R Dennis, Indiana University, [ardennis@indiana.edu](mailto:ardennis@indiana.edu)

Hello Dr. Dennis,

My name is Debbie Herd. I am a PhD candidate at the University of TX at Tyler, College of Business in the HR Development Program. I am preparing my doctoral dissertation proposal tentatively titled, "Performance Appraisal Satisfaction through the Lens of a Distributed Workplace Arrangement." I am using procedural justice, leader-member exchange and media richness theory constructs on performance appraisal satisfaction.

I am writing to you to request your permission to use the perceived media richness scale referenced in this article – Dennis, A. R., & Kinney, S. T. (1998). Testing media richness theory in the new media: The effects of cues, feedback, and task equivocality. *Information Systems Research*, 9(3), 256-274.

Items:

When we disagreed, the communication conditions made it more difficult for us to come to agreement.

\*When we disagreed, our communication environment helped us come to a common position.

The conditions under which we were communicating got in the way of our sharing of opinions.

\*I could easily explain things in this environment.

\*The communication conditions helped us communicate quickly.

I couldn't easily communicate some ideas to my manager because of the communication conditions.

\*The communication condition under which we communicated helped us to better understand each other.

The communication condition under which we were communicating slowed down our communications.

\*reverse coded

Response Anchors:

Strongly Agree

Slightly Agree

Agree

Neutral

Slightly Disagree

Disagree

Strongly Disagree

Please let me know if you have any questions or I have captured the scale incorrectly. I can be reached at [dherd@patriots.utttyler.edu](mailto:dherd@patriots.utttyler.edu) or at 214 998 1919. My dissertation chair is Dr. Ann Gilley. She can be reached at [agilley@utttyler.edu](mailto:agilley@utttyler.edu).

Thank you in advance for the consideration. Your prompt reply would be very much appreciated.



## **Appendix E: Performance Appraisal Satisfaction Measure**

(Dusterhoff et al., 2014)

### **Items:**

I felt satisfied with the performance review session

Overall I felt that the performance review process (including the planning and focusing phases) was valuable

I have positive expectations of future performance review meetings

I agreed with my performance review result

### **Response Anchors:**

Strongly disagree

Disagree

Neutral

Agree

Strongly agree

## Appendix F: Leader-Member Exchange Measure

(Graen & Uhl-Bien, 1995)

### Items and Related Response Anchors:

Do you know where you stand with your leader...do you usually know how satisfied your leader is with what you do?

Rarely  
Occasionally  
Sometimes  
Fairly Often  
Very Often

How well does your leader understand your job problems and needs?

Not a Bit  
A Little  
A Fair Amount  
Quite a Bit  
A Great Deal

How well does your leader recognize your potential?

Not at All  
A Little  
Moderately  
Mostly  
Fully

Regardless of how much formal authority he/she has built into his/her position, what are the chances that your leader would use his/her power to help you solve your problems in your work?

None  
Small  
Moderate  
High  
Very High

Again, regardless of the amount of formal authority your leader has, what are the chances that he/she would "bail you out" at his/her expense? (What are the chances that you would?)

None  
Small  
Moderate  
High  
Very High

I have enough confidence in my leader that I would defend and justify his/her decision if he/she were not present to do so?

Strongly Disagree

Disagree

Neutral

Agree

Strongly Agree

How would you characterize your working relationship with your leader?

Extremely Ineffective

Worse Than Average

Average

Better Than Average

Extremely Effective

## **Appendix G: Procedural Justice Measure**

(Colquitt, 2001, p. 389; Colquitt, Greenberg, & Zapata-Phelan, 2005, p. 131)

### **Items:**

Have you been able to express your views and feelings during performance appraisal procedures?

Have you had influence over the outcome arrived at by the performance appraisal procedures?

Have the performance appraisal procedures been applied consistently?

Have the performance appraisal procedures been free of bias?

Have the performance appraisal procedure's been based on accurate information?

Have you been able to appeal the outcome arrived at by performance appraisal procedures?

Have the performance appraisal procedures upheld ethical and moral standards?

### **Response Anchors:**

To a Very Small Extent

To a Small Extent

To a Moderate Extent

To a Large Extent

To a Very Large Extent

## Appendix H: Perceived Measure Media Richness Measure

(Daft & Lengel, 1986)

### Items:

When we disagreed, the communication conditions made it more difficult for us to come to agreement.

\*When we disagreed, our communication environment helped us come to a common position.

The conditions under which we were communicating got in the way of our sharing of opinions.

\*I could easily explain things in this environment.

\*The communication conditions helped us communication quickly.

I couldn't easily communicate some ideas to my manager because of the communication conditions.

\*The communication condition under which we communicated helped us to better understand each other.

The communication condition under which we were communicating slowed down our communications.

\*reverse coded

### Response Anchors:

Strongly Agree

Slightly Agree

Agree

Neutral

Slightly Disagree

Disagree

Strongly Disagree

## Appendix I: Communication Frequency Measure

(McAllister, 1995)

### Items:

How frequently do you:

~~\*Write memos to your boss?~~ Send text messages to your boss?

~~\*Receive memos from your boss?~~ Receive text messages from your boss?

Initiate face-to-face conversations with your boss?

Have face-to-face conversations with your boss that were initiated by him or her?

~~\*Send your boss an electronic mail message?~~ Send your boss an email?

~~\*Receive an electronic mail message from your boss?~~ Receive an email from your boss?

Call your boss on the phone?

Receive phone calls from your boss?

### Response Anchors:

Less than once a month

Once or twice a month

Once or twice a week

Once a day

More than once a day

\*Items were updated to represent a more contemporary communication modality.

## Appendix J: Extent of Distributed Workplace Measure

(Rockmann & Pratt, 2015)

### Items and Related Anchor Responses

On average each week, what is the percentage of time you spend working offsite?"

- 5%
- 10%
- 15%
- 20%
- 25%
- 30%
- 35%
- 40%
- 45%
- 50%
- 55%
- 60%
- 65%
- 70%
- 75%
- 80%
- 85%
- 90%
- 95%
- 100%

How many hours do you spend each week working onsite?

- 5
- 10
- 15
- 20
- 25
- 30
- 35
- 40 or more

How many hours do you spend each week working offsite?

- 5
- 10
- 15
- 20
- 25
- 30
- 35
- 40 or more

## Appendix K: Participant Recruitment Email

DATE

COMPANY NAME, in collaboration with, Debra (Debbie) Herd, a doctoral student at The University of Texas at Tyler, is currently participating in a research study involving performance appraisal satisfaction in distributed workplace arrangements.

As you may have read, performance management and appraisals have been under scrutiny lately. This is due in part to changing organizational needs and that some companies are trying new approaches, such as, asking their managers to provide performance feedback in different ways. At the same time, more and more managers and employees are working at different locations for all or some of their workweeks. When this happens, the challenge of providing timely and rich performance feedback can be difficult.

To that end, Debbie, in conjunction with researchers at the University of Texas at Tyler, developed a web-based survey designed to better understand the perceptions and nuances of the performance appraisals. I have given her approval to conduct this study at COMPANY NAME, and I am emailing you to make you aware of the web link that will allow you to complete the survey should you wish to participate. Debbie has had no involvement in the selection of participants for this survey.

Your taking part in this web survey is completely voluntary and you may complete it during work hours. Should you choose to participate, your survey responses will be anonymous and will only be seen by the research team at The University of Texas at Tyler. The survey instrument does not collect any identifying information, and neither I nor Debbie nor anyone else will ever know who participates. Debbie has assured me that the information she collects will be kept private and used only for this study we are discussing. Further, please note that no incentives are being provided for participation in this survey.

Debbie may use the aggregated data to support her research interests through publication, conference venues, but no identifiable characteristics – including the identification of COMPANY NAME – will ever be used. However, she does plan to share the summarized results with me and I will share them with you, regardless of actual participation) in the hopes they may guide us in sustaining an even stronger performance management program that brings out the best in all of our COMPANY NAME employees.

If you have any questions or concerns, just let me know or direct your questions to Dr. Gloria Duke, The University of Texas at Tyler at (903) 566-7023. If you are interested in participating in this study, please click the following link by DATE:

WEBLINK

Thank you,  
EXECUTIVE NAME



## Appendix L: Research Survey Instrument

(With question numbers and coded values)

### Performance Appraisal Satisfaction Survey

Q1



#### Q75 Welcome!

Q67 Welcome to this survey for employees and their perceptions about performance appraisals. The first step is to make sure you understand the purpose of this survey and to seek your consent to participate.

#### Q6 Informed Consent

Q7 Informed Consent (On-line and Anonymous) to Participate in Research  
Institutional Review Board #: S2016-43  
Approval Date: January 22, 2016

You have been invited to participate in this study, titled, "An Examination of Performance Appraisal Satisfaction through the Lens of Distributed Workplace Arrangements." The purpose of this study is to examine the social context of distributed workplace arrangements on performance appraisal satisfaction.

Your participation is completely voluntary, and if you begin participation and choose to not complete it, you are free to not continue without any adverse consequences.

If you agree to be in this study, we will ask you to do the following things:

- Answer multiple-choice questions related to the satisfaction of your performance appraisal, you and your manager's relationship, appraisal procedures, and how frequently you and your manager communicate.
- Take 15-30 minutes to complete this survey.

We know of no known risks to this study, other than becoming a little tired of answering the questions or you may even become a little stressed or distressed when answering some of the

questions. If this happens, you are free to take a break and return to the survey to finish it, or, you can discontinue participation without any problems. Potential benefits to this study are helping organizations implement more satisfying performance appraisal programs for all employees and especially for employees who work at a distance from their managers.

-----

I know my responses to the questions are anonymous. If I need to ask questions about this study, I can contact the principle researcher, Debra Herd (dherd@patriots.uttyler.edu), or if I have any questions about my rights as a research participant, I can contact Dr. Gloria Duke, Chair of the University of Texas at Tyler Institutional Review Board at gduke@uttyler.edu, or 903-566-7023. I have read and understood what has been explained to me. If I choose to participate in this study, I will click “Yes” in the box below and proceed to the survey. If I choose to not participate, I will click “No” in the box.

- Yes, I choose to participate in this study. (1)
- No, I choose to not participate in this study. (2)

**Q69 Preliminary questions...**

Q74 Are you at least 18 years of age?

- Yes (1)
- No (2)

Q68 Are you employed full-time?

- Yes (1)
- No (2)

Q3 Do you work in the U.S.?

- Yes (1)
- No (2)

Q4 Is your employer based in the U.S.?

- Yes (1)
- No (2)

Q5 Have you received a performance review (appraisal) in the last 24 months?

- Yes (1)
- No (2)

**Q8 Regarding your last performance appraisal (review)...**

Q9 I felt satisfied with the performance appraisal (review) session.

- Strongly Disagree (1)

- Disagree (2)
- Neutral (3)
- Agree (4)
- Strongly Agree (5)

Q10 Overall I felt that the performance appraisal (review) process was valuable.

- Strongly Disagree (1)
- Disagree (2)
- Neutral (3)
- Agree (4)
- Strongly Agree (5)

Q11 I have positive expectations of future performance appraisal (review) sessions.

- Strongly Disagree (1)
- Disagree (2)
- Neutral (3)
- Agree (4)
- Strongly Agree (5)

Q12 I agreed with my performance appraisal (review) result.

- Strongly Disagree (1)
- Disagree (2)
- Neutral (3)
- Agree (4)
- Strongly Agree (5)

Q13 **Regarding your relationship with your manager (leader)...**

Q14 Do you know where you stand with your manager...that is, do you usually know how satisfied your manager is with what you do?

- Rarely (1)
- Occasionally (2)
- Sometimes (3)
- Fairly Often (4)
- Very Often (5)

Q15 How well does your manager understand your job problems and needs?

- Not a Bit (1)
- A Little (2)
- A Fair Amount (3)
- Quite a Bit (4)

A Great Deal (5)

Q16 How well does your manager recognize your potential?

Not at All (1)

A Little (2)

Moderately (3)

Mostly (4)

Fully (5)

Q17 Regardless of how much formal authority he/she has built into his/her position, what are the chances that your manager would use his/her power to help you solve your problems in your work?

None (1)

Small (2)

Moderate (3)

High (4)

Very High (5)

Q18 Again, regardless of the amount of formal authority your manager has, what are the chances that he/she would “bail you out” at his/her expense?

None (1)

Small (2)

Moderate (3)

High (4)

Very High (5)

Q19 I have enough confidence in my manager that I would defend and justify his/her decision if he/she were not present to do so?

Strongly Disagree (1)

Disagree (2)

Neutral (3)

Agree (4)

Strongly Agree (5)

Q20 How would you characterize your working relationship with your manager?

Extremely Ineffective (1)

Worse than Average (2)

Average (3)

Better than Average (4)

Extremely Effective (5)

**Q21 Regarding performance review (appraisal) procedures...**

Q22 Have you been able to express your views and feelings during performance appraisal (review) procedures?

- To a Very Small Extent (1)
- To a Small Extent (2)
- To a Moderate Extent (3)
- To a Large Extent (4)
- To a Very Large Extent (5)

Q23 Have you had influence over the outcome arrived at by the performance appraisal (review) procedures?

- To a Very Small Extent (1)
- To a Small Extent (2)
- To a Moderate Extent (3)
- To a Large Extent (4)
- To a Very Large Extent (5)

Q24 Have the performance appraisal (review) procedures been applied consistently?

- To a Very Small Extent (1)
- To a Small Extent (2)
- To a Moderate Extent (3)
- To a Large Extent (4)
- To a Very Large Extent (5)

Q25 Have the performance appraisal (review) procedures been free of bias?

- To a Very Small Extent (1)
- To a Small Extent (2)
- To a Moderate Extent (3)
- To a Large Extent (4)
- To a Very Large Extent (5)

Q26 Have the performance appraisal (review) procedure's been based on accurate information?

- To a Very Small Extent (1)
- To a Small Extent (2)
- To a Moderate Extent (3)
- To a Large Extent (4)
- To a Very Large Extent (5)

Q27 Have you been able to appeal the outcome arrived at by performance appraisal (review) procedures?

- To a Very Small Extent (1)
- To a Small Extent (2)
- To a Moderate Extent (3)
- To a Large Extent (4)
- To a Very Large Extent (5)

Q28 Have the performance appraisal (review) procedures upheld ethical and moral standards?

- To a Very Small Extent (1)
- To a Small Extent (2)
- To a Moderate Extent (3)
- To a Large Extent (4)
- To a Very Large Extent (5)

Q29 I agreed with my performance appraisal (review) result.

- To a Very Small Extent (1)
- To a Small Extent (2)
- To a Moderate Extent (3)
- To a Large Extent (4)
- To a Very Large Extent (5)

**Q30 Regarding how often you communicate with your manager (leader)...**

Q31 How frequently do you send text messages to your manager?

- Less than once a month (1)
- Once or twice a month (2)
- Once or twice a day (3)
- Once a day (4)
- More than once a day (5)

Q32 How frequently do you receive text messages from your manager?

- Less than once a month (1)
- Once or twice a month (2)
- Once or twice a day (3)
- Once a day (4)
- More than once a day (5)

Q33 How frequently do you initiate face-to-face conversations with your manager?

- Less than once a month (1)
- Once or twice a month (2)
- Once or twice a day (3)
- Once a day (4)

- More than once a day (5)

Q34 How frequently do you have face-to-face conversations with your manager that were initiated by him or her?

- Less than once a month (1)
- Once or twice a month (2)
- Once or twice a day (3)
- Once a day (4)
- More than once a day (5)

Q35 How frequently do you send your manager an email?

- Less than once a month (1)
- Once or twice a month (2)
- Once or twice a day (3)
- Once a day (4)
- More than once a day (5)

Q36 How frequently do you receive an email from your manager?

- Less than once a month (1)
- Once or twice a month (2)
- Once or twice a day (3)
- Once a day (4)
- More than once a day (5)

Q37 How frequently do you call your manager on the phone?

- Less than once a month (1)
- Once or twice a month (2)
- Once or twice a day (3)
- Once a day (4)
- More than once a day (5)

Q38 How frequently do you receive phone calls from your manager?

- Less than once a month (1)
- Once or twice a month (2)
- Once or twice a day (3)
- Once a day (4)
- More than once a day (5)

Q43 **Referencing the ways you communicated with your manager from your previous responses...**

Q44 When you and your manager disagreed, the communication conditions made it more difficult for you to come to agreement.

- Strongly Agree (1)
- Agree (2)
- Slightly Agree (3)
- Neutral (4)
- Slightly Disagree (5)
- Disagree (6)
- Strongly Disagree (7)

Q45 When you and your manager disagreed, your communication environment helped you come to a common position.

- Strongly Agree (7)
- Agree (6)
- Slightly Agree (5)
- Neutral (4)
- Slightly Disagree (3)
- Disagree (2)
- Strongly Disagree (1)

Q46 The conditions under which you and your manager were communicating got in the way of sharing of opinions.

- Strongly Agree (1)
- Agree (2)
- Slightly Agree (3)
- Neutral (4)
- Slightly Disagree (5)
- Disagree (6)
- Strongly Disagree (7)

Q47 You could easily explain things in this environment.

- Strongly Agree (7)
- Agree (6)
- Slightly Agree (5)
- Neutral (4)
- Slightly Disagree (3)
- Disagree (2)
- Strongly Disagree (1)



Q48 The communication conditions helped you and your manager communicate quickly.

- Strongly Agree (7)
- Agree (6)
- Slightly Agree (5)
- Neutral (4)
- Slightly Disagree (3)
- Disagree (2)
- Strongly Disagree (1)

Q49 You couldn't easily communicate some ideas to your manager because of the communication conditions.

- Strongly Agree (1)
- Agree (2)
- Slightly Agree (3)
- Neutral (4)
- Slightly Disagree (5)
- Disagree (6)
- Strongly Disagree (7)

Q50 The communication condition under which you communicated helped both of you to better understand each other.

- Strongly Agree (7)
- Agree (6)
- Slightly Agree (5)
- Neutral (4)
- Slightly Disagree (3)
- Disagree (2)
- Strongly Disagree (1)

Q51 The communication condition under which you were communicating slowed down your communications.

- Strongly Agree (1)
- Agree (2)
- Slightly Agree (3)
- Neutral (4)
- Slightly Disagree (5)
- Disagree (6)
- Strongly Disagree (7)

**Q39 Regarding where you work, on-site, on the road, virtually...**

Q40 Does your job require you to work on the road or away from your company's office? For example, like a regional salesperson or a delivery driver?

- Yes (1)
- No (2)

Q72 Do you participate in flexible or alternative work arrangement at your company?

- Yes (1)
- No (2)

Q71 On average each week, what is the percentage of time you spend working virtually/remotely?

- 0%, I don't work virtually or remotely at all. (1)
- 5% (2)
- 10% (3)
- 20% (4)
- 30% (5)
- 40% (6)
- 50% (7)
- 60% (8)
- 70% (9)
- 80% (10)
- 90% (11)
- 100% (12)

Q42 On average, how many hours do you spend each week working virtually/remotely?

- 0, I don't work virtually or remotely at all. (1)
- 4 hours (2)
- 8 hours (3)
- 12 hours (4)
- 16 hours (5)
- 20 hours (6)
- 24 hours (7)
- 28 hours (8)
- 32 hours (9)
- 36 hours (10)
- 40 hours or more. (23)

Q41 On average, how many hours do you spend each week working on-site?

- 0, I don't work on site. (1)

- 4 hours (2)
- 8 hours (3)
- 12 hours (4)
- 16 hours (5)
- 20 hours (6)
- 24 hours (7)
- 28 hours (8)
- 32 hours (9)
- 36 hours (10)
- 40 hours or more. (23)

**Q52 Almost done...**

Q53 How old are you?

- 18-21 years old (1)
- 22-30 years old (2)
- 31-40 years old (3)
- 41-50 years old (4)
- 51-60 years old (5)
- 61-70 years old (6)
- 71+ years old (7)

Q54 What is your gender?

- Female (1)
- Male (2)

Q56 If you work virtually/remotely to any extent, how long have you been doing so?

- 0-2 years (1)
- 3-5 years (2)
- 6-10 years (3)
- 11-15 years (4)
- 21-25 years (5)
- 25+ years (6)

Q55 How long have you been with your current company?

- 0-2 years (1)
- 3-5 years (2)
- 6-10 years (3)
- 11-15 years (4)
- 21-25 years (5)
- 25+ years (6)

Q70 Which one of the following categories best describes your company's industry?

- Academic/Education/Teacher (1)
- Accounting (2)
- Administration & Support (3)
- Advertising/Public Relations (4)
- Aerospace/Defense (5)
- Banking/Finance/Insurance (6)
- Construction/Building Services (7)
- Consulting (8)
- Engineering (9)
- Healthcare (10)
- Hotel/Restaurant (11)
- HR/Recruitment (12)
- Information Technology (13)
- Legal (14)
- Logistics (15)
- Management (16)
- Manufacturing (17)
- Marketing (18)
- Mining/Oil and Gas (19)
- Operations (20)
- Other (21)
- Product Development (22)
- Professional Services (23)
- Purchasing (24)
- Quality Control (25)
- Real Estate (26)
- Research and Development (27)
- Retail Buying/Merchandising/Sales (28)
- Sales (29)
- Security (30)
- Social Service (31)
- Social Work (32)
- Transportation/Warehousing (33)
- Travel and Entertainment (34)
- Waste Management (35)
- Wholesale Trade (36)

Q58 Your last performance appraisal (review) was conducted with your manager in the following way...

- Face-to-face (1)
- Via video conference (2)
- Via telephone (3)
- Via an exchange of notes, emails or documents (4)
- Other (5)

Q59 What was your last (most recent) performance appraisal rating?

- None (0)
- Unsatisfactory - Very Poor (1)
- Does Not Meet Expectations - Poor (2)
- Meets Expectations - Medium (3)
- Above Expectations - Good (4)
- Exceeds Expectations - Excellent (5)

## Appendix M: Informed Consent

Informed Consent (On-line and Anonymous) to Participate in Research Institutional Review Board # XXXXX  
Approval Date: XXXX

You have been invited to participate in this study, titled, "An Examination of Performance Appraisal Satisfaction through the Lens of Distributed Workplace Arrangements." The purpose of this study is to examine the social context of distributed workplace arrangements on performance appraisal satisfaction. Your participation is completely voluntary, and if you begin participation and choose to not complete it, you are free to not continue without any adverse consequences.

If you agree to be in this study, we will ask you to do the following things:

- Answer multiple-choice questions related to the satisfaction of your performance appraisal, you and your manager's relationship, appraisal procedures, and how frequently you and your manager communicate.
- Take 15-30 minutes to complete this survey.

We know of no known risks to this study, other than becoming a little tired of answering the questions or you may even become a little stressed or distressed when answering some of the questions. If this happens, you are free to take a break and return to the survey to finish it, or, you can discontinue participation without any problems. Potential benefits to this study are helping organizations implement more satisfying performance appraisal programs for all employees and especially for employees who work at a distance from their managers.

---

I know my responses to the questions are anonymous. If I need to ask questions about this study, I can contact the principle researcher, Debra Herd ([dherd@patriots.uttyler.edu](mailto:dherd@patriots.uttyler.edu)), or if I have any questions about my rights as a research participant, I can contact Dr. Gloria Duke, Chair of the UT Tyler Institutional Review Board at [gduke@uttyler.edu](mailto:gduke@uttyler.edu), or 903-566-7023.

I have read and understood what has been explained to me. If I choose to participate in this study, I will click "Yes" in the box below and proceed to the survey. If I choose to not participate, I will click "No" in the box.

- Yes, I choose to participate in this study. (1)
- No, I choose to not participate in this study. (2)

## Appendix N: University of Texas at Tyler Institutional Review Board Approval



THE UNIVERSITY OF TEXAS AT TYLER  
3900 University Blvd. • Tyler, TX 75799 • 903.565.5774 • FAX: 903.565.5858

Office of Research and  
Technology Transfer

Institutional Review Board

January 22, 2016

Dear Debra Herd,

Your request to conduct the study: *An Examination of Performance Appraisal Satisfaction through the Lens of a Distributed Workplace Arrangement*, IRB #S2016-43 has been approved by The University of Texas at Tyler Institutional Review Board as a study exempt from further IRB review. This approval includes a waiver of signed, written informed consent. In addition, please ensure that any research assistants are knowledgeable about research ethics and confidentiality, and any co-investigators have completed human protection training within the past three years, and have forwarded their certificates to the IRB office (G. Duke).

**Please review the UT Tyler IRB Principal Investigator Responsibilities, and acknowledge your understanding of these responsibilities and the following through return of this email to the IRB Chair within one week after receipt of this approval letter:**

- Prompt reporting to the UT Tyler IRB of any proposed changes to this research activity
- **Prompt reporting to the UT Tyler IRB and academic department administration will be done of any unanticipated problems involving risks to subjects or others**
- Suspension or termination of approval may be done if there is evidence of any serious or continuing noncompliance with Federal Regulations or any aberrations in original proposal.
- Any change in proposal procedures must be promptly reported to the IRB prior to implementing any changes except when necessary to eliminate apparent immediate hazards to the subject.

Best of luck in your research, and do not hesitate to contact me if you need any further assistance.

Sincerely,

Gloria Duke, PhD, RN  
Chair, UT Tyler IRB

EQUAL OPPORTUNITY EMPLOYER

