

# Development of Wireless Electronic Nose Using NRF24L01 RF Transceiver for Toxic Gases Monitoring

M.H.Mustafa<sup>1</sup>, A.H.Abdullah<sup>1</sup>, M.J.Masnan<sup>2</sup> and M.A.A.Bakar<sup>1</sup>

<sup>1</sup>School of Mechatronic Engineering, Universiti Malaysia Perlis (UniMAP), Putra Pauh Campus, Perlis, Malaysia

<sup>2</sup>Institute of Engineering Mathematics, Universiti Malaysia Perlis (UniMAP), Putra Pauh Campus, Perlis, Malaysia  
hajazi@gmail.com

**Abstract**—Exposure to toxic gases will affect the well-being of people in the nearby area if it is not carefully monitored. This study proposes a Wireless Electronic Nose (e-nose) System to monitor some toxic gases, temperature and humidity in the environment. The environment is monitored by using four units of wireless e-nose known as node, positioned at pre-determined locations. The node consists of toxic gases sensors as well as temperature and humidity sensor that acquired data from the environment in 30 minutes interval. The acquired data is sent wirelessly to the main node through NRF24L01 Radio Frequency (RF) transceiver. The main node transmits the data to a web of things system via Mobile Communication/General Radio Packet Service (GSM/GPRS) module. The acquired data is analysed using Principal Component Analysis (PCA), Hierarchical Cluster Analysis (HCA) and Radial Basis Function (RBF) of the Artificial Neural Network (ANN). Initial result shows that the system is able to monitor the toxic gases in the testing area.

**Index Terms**—NRF24L01 RF Transceiver; Multivariate Data analysis; Toxic Gases Monitoring; Wireless Electronic Noses.

## I. INTRODUCTION

The environmental monitoring specifically for toxic gases is an essential process to determine the air pollution of the area [1]. People who spend long hours in the contaminated area might be affected by the air pollution with symptoms such as allergies, irritations and infections that are known as Sick Building Syndrome (SBS) [2]. The effect of air pollution is diverse depends on the area, intensity and the exposure time [3]. However, the use of single sensor meter for monitoring toxic gases is ineffective due to the characteristics of the air pollution. The propagation of toxic gases in environments is related to complex fluid dynamics characteristic such as turbulence and diffusion [4].

Generally, data logger is used to collect the air sample data but the technique is time-consuming and less effective. Hence, an effective technique that can acquire the air sample data automatically and remotely is needed.

As an alternative, an Electronic Nose (e-nose) that is widely used in many applications such as food quality, medical process, product quality control and environmental monitoring [5] is applied. The instrument is suitable for field air monitoring applications because it could provide rapid response, ease of operations and sufficient detection limits [6]. The instrument is deployed with a wireless system. Thus air sample and environmental data from a remote location can be managed and processed by a web of things system [7].

In this paper, the wireless e-nose system that uses NRF24L01 RF Transceiver is proposed for the toxic gases monitoring. If the toxic gases exceed the safety limit, the system will activate the control system where SMS will be sent to the safety officer, trigger the alarm and activate the biomaterial that will reduce the toxic gases concentration.

## II. SYSTEM DESCRIPTION

The system will monitor the toxic gases concentration in the environment as illustrated in Figure 1. The wireless e-nose system comprised of four units of e-nose and each unit would function as node, main node, NRF24L01 RF transceiver and GSM/GPRS which linked wirelessly to a web of things system as depicted in Figure 2.



Figure 1: The toxic gases monitoring system

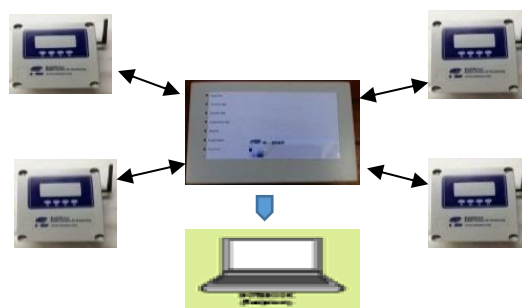

Figure 2: The wireless e-nose system

### A. The Node

The node (e-nose) main components are shown in Figure 3. The components consist of sensing unit, signal conditioning unit, processing unit, keypad, Liquid Crystal Display (LCD) and power supply unit.

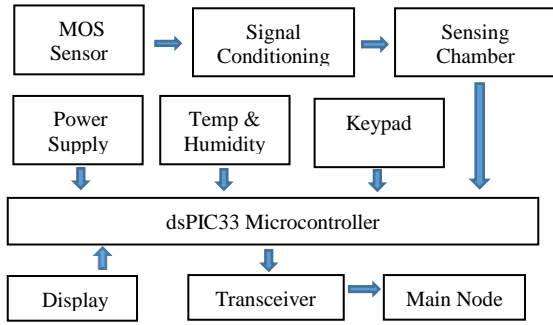

Figure 3: The wireless e-nose block diagram

The air sample flow and dynamic diffusive characteristics in the node sensing chamber are analysed using *Navier-Stokes* equation. The chamber design uses the serial sensor cell structure. The chamber size will ensure homogenous air sample flow to individual sensor irrespective of their positions. The chamber structure used Teflon as the material to minimise the air sample memory effect [8].

The node sensing unit used commercial Metal Oxide Sensor (MOS) which requires high working temperatures because it is coupled with micro-hotplates to increase the sensitive layer temperature [9]. The number of sensors used is based on the toxic gases types in the affected area, typically from 5 to 20 [10]. The main types of toxic gases for air pollution are Carbon Monoxide (CO), Ammonia (NH<sub>3</sub>), Hydrogen Sulfide (H<sub>2</sub>S), and air contaminants [11]. The node uses NH<sub>3</sub> and air contaminant sensors from Figaro Engineering. It also uses H<sub>2</sub>S sensors from Synkera Technologies Inc. A dust sensor from Sharp Inc. and a humidity and temperature sensor, SHT-75 from Sensirion Technology is attached to the node enclosure. The SHT-75 is an integrated device which operates using a single power supply with voltage output range from 0 to 3.3 volts DC. The temperature range is from -40 °C to 123.8 °C with humidity from 0 to 100% RH [12].

The node uses a dsPIC33 microcontroller from Microchip Inc., with embedded software for system control and data acquisition. The microcontroller system is selected because of its high processing power, large memory and simple interface circuit [13]. The microcontroller high processing speed (40 MIPS) and the 16-bit data bus is suitable for real-time operation. Its flash memory (256 KB) and RAM (30 KB) is capable of handling the data acquisition operation and system control. Furthermore, its 12-bit Analogue to Digital Converter (ADC) conversion speed is capable of handling simultaneous data acquisition from all input channels [14].

The acquired analogue signals from sensing unit will flow through the signal conditioning circuit and built-in Analogue to Digital Converter (ADC) where it is converted to digital signals. The sensing unit and its signal conditioning circuits are mounted on a double layer Printed Circuit Board (PCB) as shown in Figure 4. The boards are placed horizontally on the left and right of the sensing chamber. A four-button keypad and 64 x 128 alphanumeric LCD are attached to the instrument enclosure. The keypad and LCD are used as the User Interface (UI) to select the node operating menu and display text message. The selected toxic gases sensors heater used a 5 volt DC power supply.

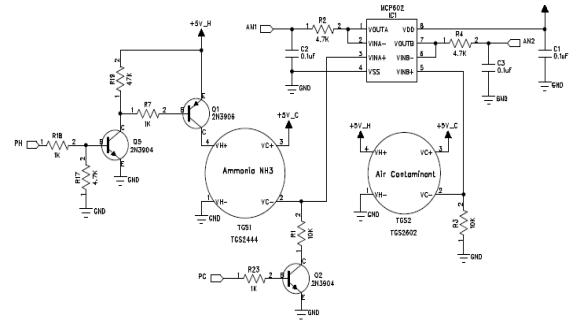

Figure 4: The MOS sensor circuit diagram

The node uses a single 12 V DC regulated power supply. The power supply circuit is developed on a single sided PCB. Three LM2575 voltage regulators are used to provide +5 volts DC for sensor biasing and its heater circuit as shown in Figure 5. An MCP1702 voltage regulator is used to provide +3.3 volts DC for the microcontroller. The node total power consumption is 1.75 watts as shown in Table 1.

Table 1  
The node power consumption

Item	Power
Sensor	800 mW
Controller board	15 mW
Signal conditioning	30 mW
Air pump	900 mW
Total power	1745 mW

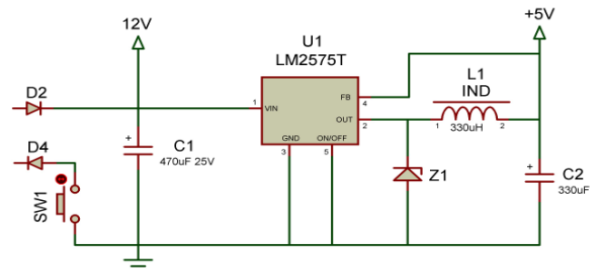

Figure 5: The DC regulated power supply

**B. Main Node**

The main node function is to manage and control all the data received from other nodes. The main node uses dsPIC33 microcontroller equipped with Universal Asynchronous Receiver/Transmitter (UART) and Serial Peripheral Interfaces (SPI). The other main components are NRF24L01 Radio Frequency (RF) transceiver and Global Systems for Mobile Communications/General Packet Radio Service (GSM/GPRS) module as shown in Figure 6.

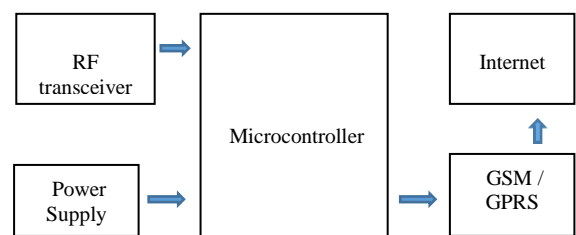

Figure 6: Master node block diagram

### C. NRF24L01 RF Transceiver

The NRF24L01 RF transceiver from Nordic Semiconductor is used to send data wirelessly from nodes to the main node through radio waves effectively. The modules operate using low-power digital radios based on the ISM 2.4 GHz for IEEE 802.15.4 standards. The RF transceiver used Interface-Segregation Principle (ISP) to connect to the dsPIC33 microcontroller [15].

The RF transceiver is easy to configure and used for low-cost network application. The RF transceiver communication distances are from 10 meters in non-line of sight to over 100 meters in a line of sight environment [16]. The system uses star topology as shown in Figure 2. These linear structure network will ensure that the main node effectively receives data from all the nodes. Each node is used to acquire data at specific locations in the environment and connected wirelessly via RF transceiver to the main node. The main node will control and transfer the data received from nodes to the internet through GSM/GPRS module. A developed web of things system will manage and analyse the acquired data.

### D. System Software

The node embedded control software is programmed using MPLAB Integrated Development Environment (IDE) with C30 compiler. The instrument initialisation is done automatically based on the embedded software. The instrument embedded software provides several display attributes such as self-diagnostic, data acquisition and transmission that can be accessed using the keypad.

Each node has its Identity Document (ID) and has to follow protocols when communicating with the main node. The sample data are acquired by the nodes in real-time and sent to the main node through wireless NRF24L01 RF transceiver in 30 minutes interval. The node operation which includes data acquisition and transmission to the main node is controlled by the embedded software. Initially, the node is in sleep mode after the data acquisition process to optimize the system power consumption.

The main node will transfer the acquired data to a web of things system by using a GSM/GPRS module from U-Blox that being programmed using M-Center software. The web of things system is developed using PHP software to manage the data sent by the main node.

The system will analyse the data using Radial Basis Function (RBF) of the Artificial Neural Network (ANN) classification model to predict the toxic gases concentration. The system will display real-time information of the toxic gases concentration. The system will generate reports on daily, weekly and monthly which can be accessed remotely through web of things system in real time.

## III. METHODOLOGY

### A. System Calibration

The calibration process will regulate the developed wireless e-nose ability to classify the varying concentration of the toxic gases. In this experiment, i.e. ammonia gas was selected as the sample. The samples of varying concentrations were prepared by diluting the solution of ammonium hydroxide with distilled water. Four different concentration of ammonia solution sample, i.e. of 20, 50, 80 and 110 part per million (ppm), were prepared in a three ml glass vial.

The experiment used static headspace technique as depicted in Figure 7. It was conducted in typical laboratory

condition with all doors and windows closed. The vial cap had a small opening for the instrument to sniff the sample volatile compounds from the headspace.

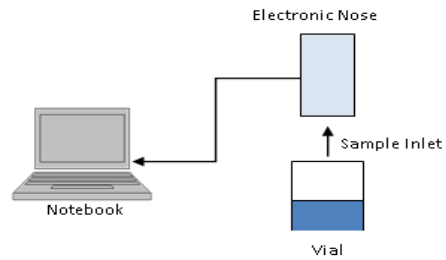

Figure 7: The static headspace sampling

### B. System Testing

The system was tested in a laboratory where each node was placed at a fix location. The distance between nodes is 10 meter and 20 meters from the main node. The system operation is shown by the flowchart in Figure 8. The main node will send commands to all nodes via NRF24L01 RF transceiver to acquire data every 30 minutes which initially in sleep mode. This procedure will reduce the node power consumption that operates using 3.3V DC volts. After receiving command from the main node, the nodes will activate and start the data acquisition process. Then the nodes will send the data to the main node using RF transceiver before goes to sleep mode again. The system is powered by 12 DC volt DC power supply.

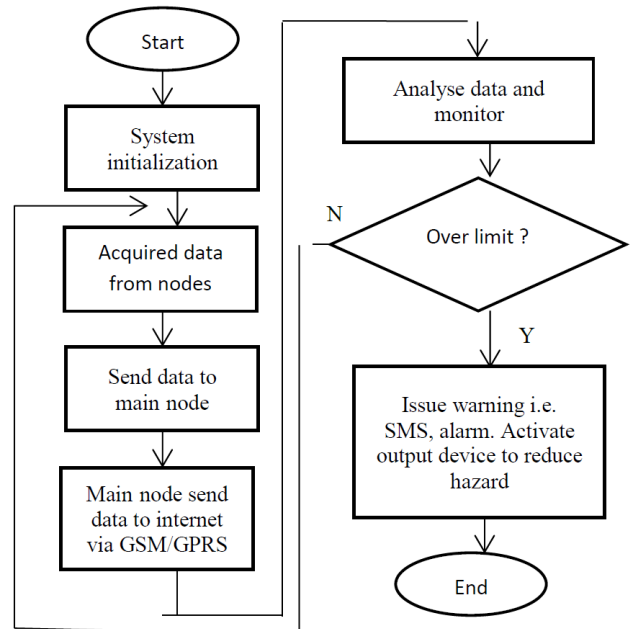

Figure 8: The system operation flowchart

## IV. RESULTS AND DISCUSSION

### A. System Calibration

The Principal Component Analysis (PCA), and Hierarchical Cluster Analysis (HCA) are used to assess the linear separability of the ammonia solution sample by using MATLAB software. The PCA plot for the sample with varying concentration is shown in Figure 9. The two dimensional PCA plot is used because the first two PCs values are more than 90% of the total variance (PC1 is 89.93% and PC2 is 9.53%) which contain most of the useful information. The

plots show that the data are clustered into four different groups. This indicates that the e-nose’s ability to differentiate sample with varying concentration.

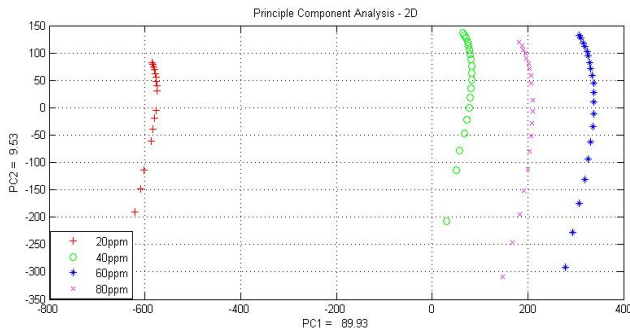

Figure 9: The PCA plot

The HCA dendrogram plot result is shown in Figure 10. The figure proved the capability of HCA to differentiate between four different concentrations of the ammonia sample.

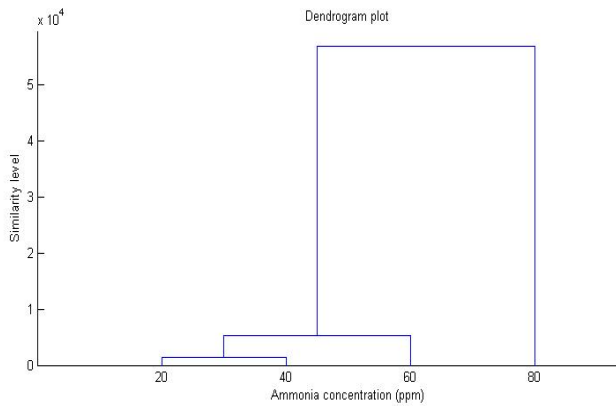

Figure 10: The HCA plot

The RBF ANN classifier is used to classify the node’s calibration data. Table 2 shows the RBF confusion matrix for the calibration of the node, where, C1 is 20 ppm, C2 is 40 ppm, C3 is 60 ppm and C4 is 80 ppm. The acquired data used for the process are split into two, 60% for the training of the RBF classification and 40% for testing the model. The model train performance achieves 100% while the test achieves 92.2% success rate. This illustrates that the node has good capability to classify the ammonia solution samples with varying concentrations.

Table 2  
The confusion matrix of the calibration

Output Class	Target Class			
	C1	C2	C3	C4
C1	128	40	0	0
C2	0	88	128	0
C3	0	0	0	128
C4	0	160	0	0

**B. System Testing**

The acquired data received by the main node from the four nodes in real time is illustrated by Figure 11. The responses of the nodes were plotted as a time series. The system sampling technique is acceptable as the data value from all the four nodes are within the range. The responses of the

sensor nodes transmitted wireless through wireless NRF24L01 RF transceiver are successfully received by the main node.

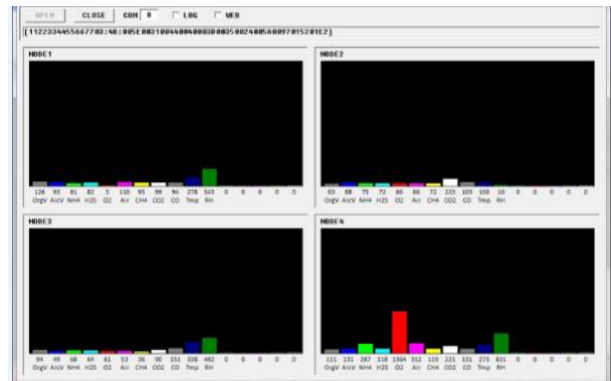

**V. CONCLUSION**

The wireless e-nose system is successfully calibrated and tested in the laboratory as the toxic gases monitoring system. The main node has acquired the data from nodes using wireless NRF24L01 RF transceiver. The RF transceiver is functioning accordingly, that enable the system to acquire data from four different selected locations. The PCA and HCA plots proved the capability of the system to differentiate the concentration of toxic gases at different locations. The RBF ANN classification model is able to predict the toxic gases concentration of the area. Based on the result, the system could be used to monitor and send warning signal when toxic gases concentration exceeds the safety limit. The toxic gases concentration can be used as a guideline by the local enforcement agencies to enable effective toxic gases monitoring.

Further work is suggested to calibrate the node to improve the generated toxic gases concentration model. Subsequently, the wireless e-nose system will be tested in the field environment. The system performance could be enhanced using the state-of-the-art sensor to reduce the temperature and humidity drift. State-of-the-art wireless transmission which reduces the transmission power and increases the range should also be considered.

**ACKNOWLEDGMENT**

This project is partly funded by the Ministry of Higher Education Malaysia under the Prototype Research Grant Scheme (PRGS) under a grant number of (PRGS/1/2015, No: 9013-00023). M.H. Mustafa also gratefully acknowledges Universiti Malaysia Perlis (UniMAP) for the opportunities given to conduct the research.

**REFERENCES**

- [1] A. Kumar, I.P. Singh & S.K. Sud, “Development of Multi-channel data logger for indoor environment,” *Engineering*, vol. 2, 2010, pp. 690-697.
- [2] S. Zampolli, I. Elmi, F. Ahmed, M. Passini, G.C. Cardinali, S. Nicoletti & L. Dori, “An electronic nose based on solid state sensor arrays for low-cost indoor air quality monitoring applications,” *Sensors and Actuators B*, vol. 101, 2004, pp. 39-46.
- [3] S. De Vito & P. Di Palma, “Wireless sensor networks for distributed chemical sensing: Addressing power consumption limits with on-board intelligence,” *IEEE Sensors*, vol.11, 2011, pp. 947-955.

- [4] T. Nakamoto & H. Ishida, "Chemical sensing in spatial/temporal domains," *Chem. Rev.*, vol. 108, no. 2, 2008, pp. 680–704.
- [5] J. Srinonchat, "Development of electronic nose and program for monitoring air pollutions and alarm in industrial area," *Int. Journal of Computer and Electrical Engineering*, vol. 5, no. 1, 2013, pp. 61 – 64.
- [6] E.B. Soyer, B.U. Toreyin, A.E. Cetin & F. Erden, "VOC gas leak detection using pyro-electric infrared sensors," *IEEE Int. Con. on Acoustics Speech & Signal Processing*, 2010, pp. 1682 – 1685.
- [7] P. Leilei & S.X. Yang, "An electronic nose network system for online monitoring of livestock farm odors," *IEEE/ASME Trans. on Mechatronics*, vol.14, no. 3, 2009, pp. 371 -376.
- [8] A.H. Abdullah, S.A. Shukor, M.S. Kamis, A.Y.M. Shakaff, A. Zakaria, N.A. Rahim, S.M. Mamduh, K. Kamarudin, F.S.A. Saad, M.J. Masnan & H. Mustafa, "Calibration of an electronic nose for poultry farm," *AIP Con. Proceedings*, vol. 1808, 2016, pp. 020002.
- [9] N. Barsan and U.Weimar, "Conduction model of metal oxide gas sensors," *Journal Electroceram.*, vol. 7, no. 3, 2001, pp. 143–167.
- [10] J.W. Gardner & P.N. Bartlett, "A brief history of electronic noses". *Sensor and Actuators B*, vol. 18-19, 1994, pp. 211-220.
- [11] T. Pogfay, N. Watthanawisuth, A. Wisitsoraat, T. Lomas & A. Tuantranont, "Industrial community odor monitoring utilizing wireless electronic nose for human health protection," 4<sup>th</sup> Int. Con. Biomedical Engineering, 2012, pp. 96-99.
- [12] Temperature & Humidity data sheet, 2011. Retrived from [https://www.sensirion.com/sensirion/Sensirion\\_Humidity/SHT75](https://www.sensirion.com/sensirion/Sensirion_Humidity/SHT75)
- [13] A. Perera, T. Sundic, A. Pardo, R. Gutierrez-Osuna & S. Marco, "A portable electronic nose based on embedded pc technology and gnu/linux: hardware, software and applications," *IEEE Sensors Journal*, vol. 2(3), 2002, pp. 235–246.
- [14] Microchip Technology Inc. Microchip dspic33fj128gp804 microcontroller. Retrieved Jan 20, 2008 from <http://ww1.microchip.com/downloads/en/DeviceDoc/39940d.pdf>.
- [15] NRF24L01+ Single Chip 2.4GHz Transceiver. Retrieved Jan 20, 2017 from [https://www.sparkfun.com/nRF24L01Plus\\_Preliminary\\_Product\\_Specification\\_v1](https://www.sparkfun.com/nRF24L01Plus_Preliminary_Product_Specification_v1).
- [16] LEON-G100/G200 Quad-band GSM/GPRS data and voice modules datasheet. Retrieved Jan 20, 2017 from [https://www2.u-blox.com/images/downloads/Product\\_Docs/](https://www2.u-blox.com/images/downloads/Product_Docs/)