

Class E ZVS Inverter Simulation for Series Resonance Mode Ultrasonic Transducer

Huzaimah Husin¹, Shakir Saat¹, Yusmarnita Yusop¹, Azmi Awang Md Isa¹, Saari Mohd Isa¹, Majid Darsono¹, Aziz Yahya² and Sing Kiong Nguang³

¹*Advanced Sensors & Embedded Control System (ASECs) Research Group, Faculty of Electronics & Computer Engineering, Universiti Teknikal Malaysia Melaka, Melaka, Malaysia*

²*Centre for Language and Human Development, Universiti Teknikal Malaysia Melaka, Melaka, Malaysia*

³*Department of Electrical & Computer Engineering, The University of Auckland, Auckland, New Zealand*
shakir@utem.edu.my

Abstract— Single-ended Class E ZVS inverter is known as higher efficiency power converter with a simple design topology. However, the efficiency of the circuit is most influenced by the variations of the connected load, especially when dealing with ultrasonic transducer. This paper presents a design of high efficiency power converter for series resonance mode ultrasonic transducer in acoustics energy transfer applications. To enhance the performance of the circuit, the tuning procedure of shunt capacitor and series inductor are delivered and as a result, 0.191 W output power is able to be transmitted successfully with 95.5% power conversion efficiency.

Index Terms— Class E ZVS Inverter; Low Power Applications; Pzt Transducer.

I. INTRODUCTION

Acoustic energy transfer (AET) is one of the promising technique used to supply power wirelessly to low power electronics appliances, due to its nature's ability to penetrate any metal and non-metal environment with a larger distance as compared to its nearest challenger; inductive power transfer (IPT) and capacitive power transfer (CPT) [1][2][3]. AET is relatively new alternative method that uses ultrasound waves or vibration to propagate energy wirelessly between the source and the load. AET gained huge attention in powering implanted devices such as pacemakers, defibrillators, heart-assist devices and implanted insulin pumps. AET offers a more safer alternative method to transmit energy wirelessly as stated in [3],[4] and [5] especially for implantable devices applications.

In order to gain sustainability and functionality of an AET system, the performance in terms of energy transfer efficiency and the power transfer capability is a vital. There are concerns regarding the attenuation of sound waves that propagates in the medium and diffraction/spreading losses which also contributes to the disruption of the origin sound waves [6][3][7]. However, the performance of the transmitter and receiver unit in the system is also believed to be a major influence to the overall efficiency. Thus it is highly recommended to design and develop the transmitter and receiver unit that have efficiency >80% [6][8] as they will disturb heavily on the overall efficiency of energy transfer system. Most of the research has been focused on the power amplifier design in looking for the higher inversion energy efficiency [9]. For high frequency

applications, the single-ended Class-E resonant inverter, which is also known as Class-E power amplifier (PA), is well identified as high efficiency converter for altering a dc power into ac power [10] [11]. At the transmitter unit, the power amplifier plays a role of driving the ultrasonic transducer at the exact operating frequency without exciting harmonic modes. Meanwhile, at the receiving unit, the circuit should capable enough to extract the maximum power that being transmitted through the propagation medium, i.e air.

An AC power that being transmitted needs to be converted into pressure energy. Ultrasonic transducer is used as a transmitting and receiving transducer at the respective units in order to convert the electrical to mechanical energy and vice versa. To achieve the optimization of ultrasonic system's performance, it is required to recognize the characteristics of the transducer involved. It is infrequent to find marketable transducers that do not exactly meet their design specifications as mentioned in datasheet, or others with degrading performance over time, thus there is a necessity for the transducer characterization[12][13] before designing the power amplifier.

The aim of this paper is to illustrate the design steps and experimental procedure of the transmitter unit in AET system based on Class E Zero Voltage Switching (ZVS) inverter topology with unloaded ultrasonic transducer characteristics under series resonance mode. Most of the previous researchers presented the initial design by setting the optimum operation for the inverter and followed by the matching technique, thus ignoring the actual characterization parameters of the ultrasonic transducer that acted as a load. In returns, the design performance will be influenced due to the sensitivity of the load variations of the inverter. The impedance of ultrasonic transducer especially in series resonance mode is key parameter that must be taken into account to ensure the highest performance of the inverter. Thus, in order to have structured design, this paper contributed the step-by-step design and experimental procedures by introducing the actual characterization parameters of ultrasonic transducer before designing the inverter as a whole.

This paper is arranged as follows: Section II describes the fundamental concept of AET system. The Class E Inverter and ultrasonic transducer characterization parameters are also highlighted in this section. Section III illustrates the design procedure of AET system, whereby utilizing the matching impedance technique that is proposed in this

paper. Meanwhile, Section IV provides the simulation results of the system. The conclusion is then drawn in Section V.

II. AET CONCEPT

The application of ultrasound wave or vibration as the medium of energy transmission made viable especially in situations where no EM fields are allowed, and high directionality of the power transfer is required [3] [4] [14] and [15]. The authors also elaborated that AET lies in the much propagation speed with respect to electromagnetic propagation velocity that make possible for the smaller dimensions of the transmitter and receiver of AET system.

A. AET System

The basic structure of AET system is shown in Figure 1. This system consists of a transmitter unit and receiver unit.

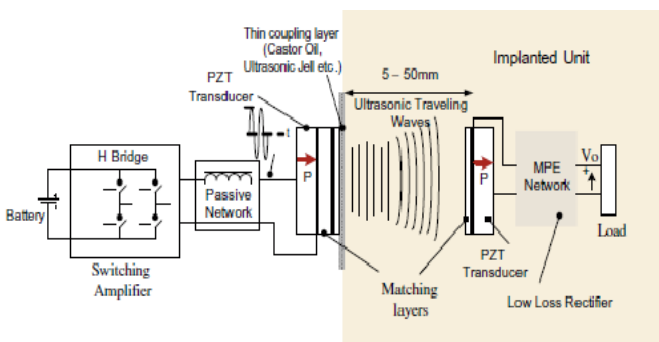

Figure 1: Acoustic Energy Transfer system [6]

A DC input will energize the transmitter transducer through the switching amplifier that converts the electrical energy to vibration or acoustics pressure waves. The acoustic waves will propagate and carry the energy through the medium toward an implanted receiver transducer that is positioned within the radiation lobe of the transmitter. A receiving unit functions for the inverse process of converting the vibration or motion caused by the waves into electrical energy. A rectifier will rectify that particular electrical energy and filters the output voltage of the receiving transducer. The usable steady dc voltage drives a load.

The power conditioning stage in the circuit will determine the overall efficiency of AET system; whether the power amplifier at the transmitter unit or power processor in the receiver unit. Both of the power conditioning at the transmitter and receiver unit must exhibit efficiency more than 80% as they affect the overall efficiency of the system. This paper focuses on developing power amplifier at the transmitter unit that applied Class E Zero-Voltage-Switching (ZVS) as dc-ac inverter. The schematic circuit of Class E ZVS inverter is illustrated in Figure 2

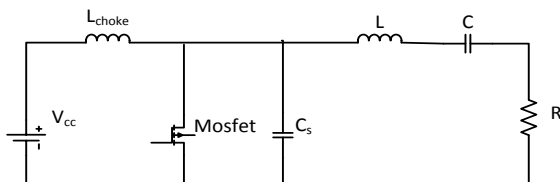

Figure 2: Schematic circuits of Class E ZVS inverter topology.[16]

The capability of Class E ZVS inverter in reducing the voltage stress and switch conduction loss in the resonant circuit [17], [16] and [18] gives us a perfect option to the research in developing high efficiency system. Also the Class E ZVS inverter still manageable to operate at the high efficiency even the varying values of the resonant components [18]. It produces a good performance and stability through adjusting the duty cycle and optimizing circuit parameters [19]. The high efficiency is contributed through the nature of switching whereby the current and voltage waveform of the switch are not overlap during the switching time intervals. Thus, with the virtually zero switching losses, the inverter produce high efficiency performance [16],[19] and [20]. It is known that Class E ZVS inverter is well established due to its performance of converting DC power to AC power at the high frequency. However, the operation of Class E ZVS inverter is sensitive to load variation [9], particularly in this application. Working slightly away from the optimum condition, might cause a large drop in its conversion efficiency.

B. Ultrasonic Transducer

The ultrasonic transducer can be modeled according to the Butterworth-Van Dyke equivalent circuit as shown in Figure 3(a), which has been extensively discussed in [12][21][22][23]. The resistance R_1 represents the mechanical dissipations, the L_1 as the mass, the capacitance C_1 as the compliance (flexibility) and the C_0 is the static capacitance of the transducer. Ultrasonic transducer works at just two difference resonance frequencies, series and parallel resonance. At the series resonance, the minimum impedance of the transducer can be determined and at the parallel resonance, the maximum impedance can be obtained. The series resonance operation is required in order to transmit the energy efficiently due to the minimum impedance and at that time, the frequency displacement is greatest whereby the actual mechanical resonance frequency occurred. At series resonance, the L_1 and C_1 will resonant and cancel each other. The ultrasonic transducer equivalent circuit at the series resonance is shown in Figure 3 (b).

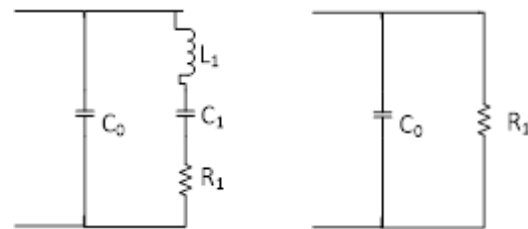

Figure 3: Schematic circuits. (a) Unloaded ultrasonic transducer electrical equivalent circuit. (b) Unloaded ultrasonic transducer electrical equivalent circuit at the series resonance mode.

III. DESIGN PRINCIPLES

In order to design and develop a complete transmitter unit, simulation process was undertaken based on the operation of Class E ZVS with simplified equivalent ultrasonic transducer circuit at the series resonance mode. The ultrasonic transducer plays a role as a load for the inverter. The combination of those two circuits is shown in Figure 4 and it is aimed to provide impedance transformation so that the maximum power can be developed and delivered. The arrangement of the designed circuit is similar to impedance

matching resonant circuit of $\pi 1a$ that was proposed in [16]. Thus, the theoretical calculation can be adapted in order to design the Class E ZVS inverter in this paper.

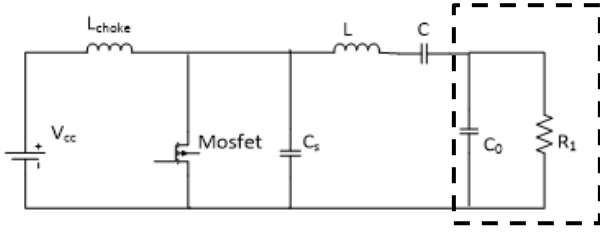

Figure 4: Schematic circuit of Class E Inverter with series resonance mode ultrasonic transducer as a load

In order to develop the Figure 4 to be in the same configuration as a standard Class E ZVS inverter, circuit arrangement in Figure 4 needs to be transformed into the equivalent circuit as illustrated in Figure 5.

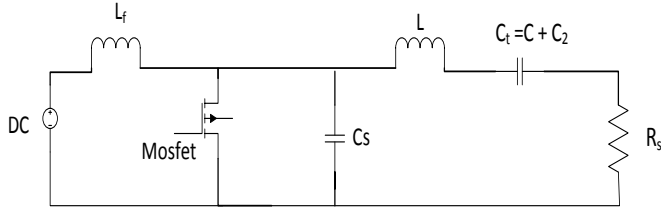

Figure 5: Equivalent circuit of the impedance matching resonant circuit $\pi 1a$ technique [16]

A. Principle of Operation

A standard circuit of Class E ZVS inverter is shown in Figure 2. It consists of power MOSFET that acts as a switch, a LCR series resonant circuit, C_s as a shunt capacitor with L_{choke} as choke inductor. The switch turns on and off at the operating frequency, $f = \omega/2\pi$ that determined by a driver, in this case PIC16F877A. Figure 4 illustrates the complete combination of Class E ZVS inverter and ultrasonic transducer equivalent circuit.

B. Assumption of analysis

Few assumptions are need for the analysis of the inverter in Figure 2;

- i. The transistor and diode form an ideal switch whose on-resistance is zero, off-resistance is ∞ , and switching time is zero.
- ii. The choke inductance is high enough so that its ac component is much lower than the DC component of the input current.
- iii. The loaded quality factor Q_L of the resonant circuit is high enough so that the currents through inductance L , capacitance C , and resistance R is sinusoidal.

C. Design Parameters

- i. Input voltage, $V_I = 12.55$ Vdc
- ii. Power at the AC load, $P_{R1} = 0.2$ W
- iii. Series resonance frequency, $f_r = 379.37$ kHz,
- iv. Working frequency, 400 kHz $\pm 5\%$
- v. Quality factor, $Q_L = 10$
- vi. Static Drain-to-Source resistance, $r_{DS} = 0.54 \Omega$
- vii. Duty cycle, $D = 0.5$

D. Ultrasonic Transducer Parameter

A precision impedance analyzer (Keysight E4990A) is used to investigate the electrical properties of the ultrasonic transducer. During the process, the measured specimen is actuated by an input sweep signal and some electrical energy converts into mechanical energy.

An ultrasonic transducer of SMATR400H99XDA by Stemic, a water proof, with nominal operating frequency of 400 kHz $\pm 5\%$, is used as a specimen transmitting transducer in this work. Key parameters of the specimen are tabulated in Table 1.

Table 1
Electrical Parameters Of The Ultrasonic Transducer

R_1, Ω	C_1, pF	L_1, mH	C_0, pF
531.04	27.76	6.34	323.78

For unloaded ultrasonic transducer element, it will exhibits series and parallel resonance and the equations as follows,

$$f_{series} = \frac{1}{2\pi\sqrt{L_1 C_1}} \quad (1)$$

$$f_{parallel} = \frac{1}{2\pi\sqrt{\frac{C_1 C_0}{C_1 + C_0}}} \quad (2)$$

E. Theoretical Calculations

In order to get the theoretical value of each component in the Figure 5 that being transformed from Figure 4, some equations are adopted from [16] and used as follows; Assume a typical value of the inverter efficiency $\eta_I = 95\%$, some relevant equations can be performed as following: The series equivalent resistance, R_s can be obtained using the relationship of R_1 and X_{C_0} as

$$R_s = \frac{R_1}{1 + \left(\frac{R_1}{X_{C_0}}\right)^2} \quad (3)$$

Meanwhile, the shunt capacitor using

$$C_s = C_0 \left[1 + \left(\frac{X_{C_0}}{R_1}\right)^2 \right] \quad (4)$$

and the series inductor can be calculated as

$$L = \frac{Q_L R_s}{\omega} \quad (5)$$

As for the choke inductor,

$$L_f = 2 \left(\frac{\pi^2}{4} + 1 \right) \frac{R_s}{f} \quad (6)$$

The reactance factor of this inverter is

$$q = \sqrt{\frac{R_1}{R_s} - 1} \quad (7)$$

From Figure 5, $C_t = C + C_2$, the reactance of series capacitor C , can be determined using

$$X_C = R_s \left[Q_L - \frac{\pi(\pi^2 - 1)}{16} - \sqrt{\frac{R_1}{R_s} - 1} \right] \quad (8)$$

and yields

$$C = \frac{X_C}{\omega} \quad (9)$$

Based on (4), (5) and (9) the value of L , C_s and C of the Class E inverter can be easily calculated.

As the aim of this paper is to produce output power at R_L , the equation (10) is used to calculate the output power required. Before that, it shall be noted that the amplitude across the capacitor C_o is the same as amplitude of the voltage across the load resistance R_L . Thus

$$V_{C0m} = V_{R1m} = \sqrt{2R_1P_o} \quad (10)$$

and the output power at the transmitting transducer can be then determined by

$$Power_{output} = \frac{\left(\frac{V_{R1}}{\sqrt{2}}\right)^2}{R_1} \quad (11)$$

The selection of IRF510 as a switching MOSFET is made due to suitable voltage rating and power dissipation regards to design specifications. Then, using equations (1)-(10), the theoretical value of each component and parameter in the combined circuits was calculated and tabulated in Table 2.

Table 2
Calculation Value For Each Component And Parameters For The Designed Circuit

Inverter Parameters	Symbol	Value
Series resonance frequency	f_{series}	379,372.44 kHz
Parallel resonance frequency	$f_{parallel}$	31,475.74 kHz
Resistance for optimum operation	R_s	454.74 Ω
Shunt capacitor	C_s	169.48 pF
Series inductor	L	1.908 mH
Choke inductor	L_f	0.832 mH
Reactance of C_0	X_{C0}	1296.487 Ω
Reactance factor	q	0.4069
Reactance of C	X_C	3837.106 Ω
Series capacitor	C	109.39 pF
Voltage across the load resistance	V_{R1m}	14.325 V
Output power	P_{out}	0.2W

IV. SIMULATION RESULT

In order to verify the designed model, simulation through Proteus Software was delivered.

A. The design of power amplifier Circuit

The circuit was designed by applying MOSFET IRF510 manufactured by Vishay as a switch that turns on and off

alternately at the switching frequency, $f = \frac{\omega}{2\pi}$. The square wave signal as a driver for the MOSFET was generated by PIC and feed into the gate of the MOSFET. The designed circuit for optimum operation with impedance matching is shown in Figure 6. Proteus simulation has been undertaken to analyze the functionality of the designed circuit. Component values were based on the previous calculation as tabulated in Table 2.

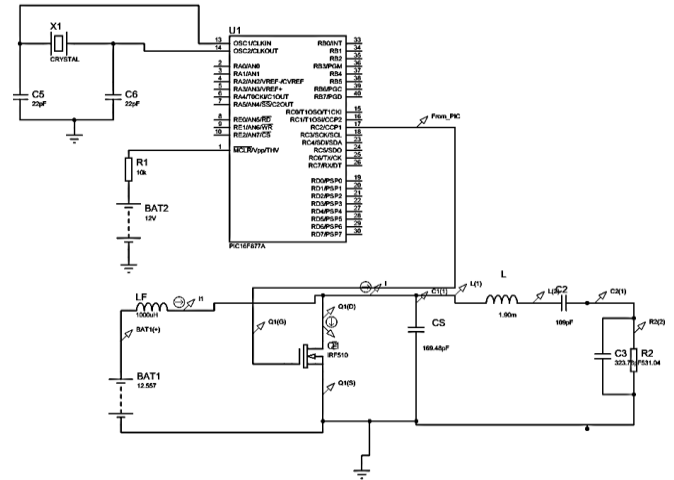

Figure 6: The schematic of Class E ZVS inverter with ultrasonic transducer as a load.

Obviously, in Eq. (3) the inverter will operate at its optimum condition when load is equal to $R_{opt} = 454.74 \Omega$. Meanwhile, the actual ultrasonic impedance is 531.04 Ω and this will force the inverter to work in the suboptimum operation area. In order to make an inverter to deliver maximum power, one of the impedance matching techniques, known as the impedance matching circuit π 1a is employed so that the impedance transformation can be conducted. The selection of impedance matching circuit π 1a circuit is arised due to similarity of circuit arrangement when the ultrasonic transducer is resonanting in series mode.

B. The signal waveforms of the Class E ZVS inverter

The generation of PWM was done by PIC16F877A with the coding simulation through mikroC PRO for PIC software. The generation of 5Vp square wave is produced by PIC with the working frequency of 416 kHz is successfully obtained and shown in Figure 7 as V_{GS} .

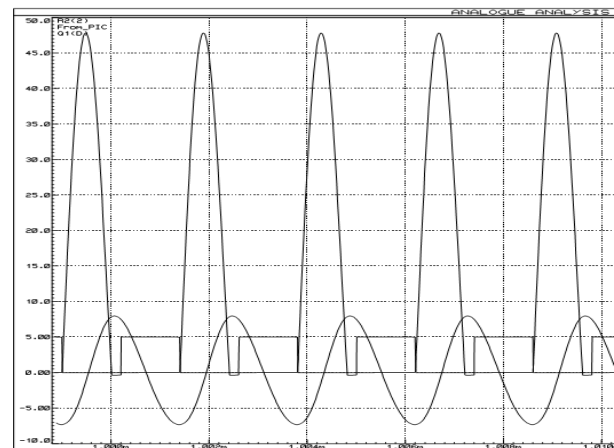

Figure 7. Simulated V_{GS} , V_{DS} and V_{output} of the Class E ZVS inverte

However, the ZVS condition is not fully obtained due to the tuning problem that often encountered in Class E inverter. This findings consistent with other research stated in [9], [24] and [25]. As consequences, the maximum output voltage that lead to maximum output power cannot be obtained using this particular calculated value.

Based on the graph shown in Figure 7, the peak output voltage obtained is $7.7V_p$, which is only 50% of targeted output voltage. Thus, it is required to tune the Class E ZVS inverter components, especially the shunt capacitor, C_s and series inductor, L in order to get the best optimum performance. The tuning process is always done by a heuristic approach until the best optimum operation is achieved.

Figure 8 exhibits the best optimum performance that can be achieved in this design to ensure the ZVS condition is fully established. The result shows that the changed occur for C_s and L values from 169.48 pF to 280 pF and 1.90 mH to 1.60 mH, respectively. These two factors act as a major role in tuning purposes for Class E ZVS inverter.

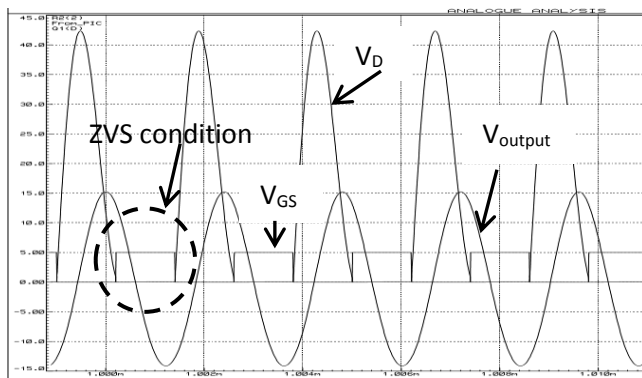

Figure 8 Simulated V_{GS} , V_{DS} and V_{output} of the Class E ZVS inverter after tuning process

The process of tuning for Class E ZVS inverter by the means of altering the value of C_s and L respectively, make it viable to bring the high efficiency of the power conversion. From the Figure 8, it can be seen that the output voltage across the R_l increased from $7V_p$ to $14.25V_p$, that related to the output power developed. Using $14.25V_p$ as a new value of VR_l , the output power of 0.191 W developed at the ultrasonic transducer as a load in the Class E ZVS inverter designed.

V. CONCLUSION

In this paper, the power amplifier namely Class E ZVS inverter is studied and designed to produce a 0.2 W output power using AET system for low power wireless energy applications. The characteristics of ultrasonic transducer under the series resonance mode are also being considered and accounted in the order to yield high power conversion efficiency system. To validate the theoretical results acquired from an established fundamental, the simulation was undertaken and the results shown that the output voltage consistent with the Class E ZVS inverter characteristics. The π 1a impedance matching circuit is applied due to mismatch of the resistance for optimum operation and the actual load impedance and it can solve the problems arose due the sensitivity of load variation in Class E ZVS inverter. With the addition of matching impedance,

the circuit still performed at low efficiency due to un-tuned of reactive component elements, especially the shunt capacitor, C_s and series inductor, L . As tuning processes undertaken, by changing the value of C_s and L , the circuit designed manage to produce an output power of 0.191 W with DC supply of $12.55V_{DC}$ at the operating frequency of 400kHz with an efficiency of 95.5%. It is believed with the step-by-step simulation illustrated in this paper will assists for those acquire such knowledge. The future works is to deliver the experimental works of the proposed method to validate the theoretical and simulation results.

ACKNOWLEDGMENT

The author would like to express a high appreciation to Universiti Teknikal Malaysia Melaka (UTeM) and Ministry Of Education Malaysia for funding this research work under RAGS/1/2014/TK03/FKEKK/B00062 grant. Also, special thanks to Advanced Sensors & Embedded Control System Research Group (ASECs), UTeM and UTP Electrical & Electronic Communication Laboratory, Universiti Teknologi Petronas for the support.

REFERENCES

- [1] M. G. L. Roes, S. Member, J. L. Duarte, M. A. M. Hendrix, E. A. Lomonova, and S. Member, "Acoustic Energy Transfer : A Review," vol. 60, no. 1, pp. 242–248, 2013.
- [2] A. Kurs, A. Karalis, R. Moffatt, J. D. Joannopoulos, P. Fisher, and M. Soljacic, "Wireless power transfer via strongly coupled magnetic resonances," *Science*, vol. 317, no. July, pp. 83–86, 2007.
- [3] T. Zaid, S. Saat, Y. Yusop, and N. Jamal, "Contactless energy transfer using acoustic approach - A review," *2014 Int. Conf. Comput. Commun. Control Technol.*, no. 14ct, pp. 376–381, Sep. 2014.
- [4] M. G. L. Roes, M. a. M. Hendrix, and J. L. Duarte, "Contactless energy transfer through air by means of ultrasound," *IECON 2011 - 37th Annu. Conf. IEEE Ind. Electron. Soc.*, pp. 1238–1243, Nov. 2011.
- [5] H. Husin, H. Hamidon, S. Saat, and Y. Yusmarnita, "Simulation of Class D resonance inverter for Acoustics Energy Transfer applications," *7th Int. Conf. Inf. Technol.*, vol. 2015, pp. 527–532, 2015.
- [6] S. Ozeri and D. Shmilovitz, "Ultrasonic transcutaneous energy transfer for powering implanted devices," *Ultrasonics*, vol. 50, no. 6, pp. 556–66, May 2010.
- [7] P. H. Vihvelin, "Design and Development of an Ultrasonic Power Transfer System for Active Implanted Medical Devices," Dalhousie University, Halifax, Canada., 2015.
- [8] S. Ozeri, D. Shmilovitz, S. Singer, and C. C. Wang, "Ultrasonic transcutaneous energy transfer using a continuous wave 650 kHz Gaussian shaded transmitter," *Ultrasonics*, vol. 50, no. 7, pp. 666–674, 2010.
- [9] J. L. Hai-Li Liu, "Design of a Class-E Inverter for piezoelectric ultrasound generation against load variation," in *2014 Symposium on Piezoelectricity, Acoustic Waves, and Device Applications*, 2014, pp. 118–121.
- [10] Nathan O. Sokal, "RF power amplifiers," *QEX*, pp. 1–20, 2001.
- [11] Marian K. Kazimierczuk, *RF Power Amplifiers*, First edit. United Kingdom: John Wiley & Sons, 2008, pp. 179–237.
- [12] R. Queirós, P. S. Girão, and A. C. Serra, "Single-Mode Piezoelectric Ultrasonic Transducer Equivalent Circuit Parameter Calculations and Optimization Using Experimental Data," no. April 2016, pp. 468–471, 2005.
- [13] V. Dumbrava and G. Motiejunas, "Ultrasonic generator-transducer combined performance enhancement," *Signal Processing*, vol. 10, no. 1, pp. 35–44, 2008.
- [14] M. G. L. Roes, M. a. M. Hendrix, and J. L. Duarte, "The effect of reflections on the performance of an acoustic energy transfer system," *2012 IEEE Energy Convers. Congr. Expo.*, pp. 388–393, 2012.
- [15] T. Zaid, S. Saat, J. Norezmi, S. H. Husin, Y. Yusof, and S. Ludin, "The Experimental Analysis of Low-Power Acoustic Energy

- Transfer System using Class E Converter,” *J. Telecommunication Electronic and Computer Engineering*, vol. 8, no. 9, pp. 1–6, 2016.
- [16] Marian K. Kazimierczuk and C. Dariusz, “Class E Zero Voltage Switching Resonant Inverter,” in *Resonant Power Converters*, 2nd ed., New Jersey: John Wiley & Sons, 2011, pp. 334–363.
- [17] D. K. Nayak and S. R. Reddy, “Performance of the push-pull LLC resonant and PWM ZVS full bridge topologies,” *J. Appl. Sci.*, vol. 11, pp. 2744–2753, 2011.
- [18] S. Q. Lee, W. Youm, and G. Hwang, “Biocompatible wireless power transferring based on ultrasonic resonance devices,” in *Proceedings of Meetings on Acoustics*, 2013, vol. 19, pp. 1–9.
- [19] W. Xiaoyuan and Y. Zhe, “Simulation of ZVS Converter and Analysis of Its Switching Loss Based on PSPICE,” *IJEPEDS*, vol. 2, no. 1, pp. 19–24, 2012.
- [20] F. K. a Rahman, S. Saat, L. H. Zamri, N. M. Husain, N. a Naim, and S. a Padli, “Design of Class-E Rectifier with DC-DC Boost Converter,” *J. Telecommun. Electron. Comput. Eng.*, vol. 8, no. 1, pp. 89–95, 2016.
- [21] S. Sherrit, H. D. Wiederick, and B. K. Mukherjee, “Accurate equivalent circuits for unloaded piezoelectric resonators,” *1997 IEEE Ultrason. Symp. Proceedings. An Int. Symp. (Cat. No.97CH36118)*, vol. 2, pp. 931–935, 1997.
- [22] P. Fabijanski and R. Lagoda, “Modeling and Identification of Parameters the Piezoelectric Transducers in Ultrasonic Systems,” in *Advances in Ceramics - Electric and Magnetic Ceramics, Bioceramics, Ceramics and Environment*, 2011, pp. 155–176.
- [23] A. W. W. A.H.Meitzler, H.F.Tiersten, “An American National Standard IEEE Standard on Piezoelectricity,” 1987.
- [24] E. Szychta, “Analysis of operation of class E ZVS resonant inverter,” *Electr. Power Qual. Util. J.*, vol. XI, no. 1, pp. 57–68, 2005.
- [25] Y. F. Li and S. M. Sue, “Exactly analysis of ZVS behavior for class e inverter with resonant components varying,” *Proc. 2011 6th IEEE Conf. Ind. Electron. Appl. ICIEA 2011*, pp. 1245–1250, 2011.