

# Application of Piezoelectric Energy Harvesting in Powering Radio Frequency (RF) Module

Ali Mohammed Abdal-Kadhim, Kok Swee Leong, Norizan Bin Mohamad  
*Faculty of Electronic and Computer Engineering,  
Universiti Teknikal Malaysia Melaka, 76100 Durian Tunggal, Melaka, Malaysia.  
P021510003@student.utm.edu.my*

**Abstract**—A radio frequency (RF) transmitter node powered with a cantilever based piezoelectric energy harvester is presented in this paper for wireless sensing applications. The piezoelectric cantilever (energy harvester) is tuned to its resonant frequency at around 290Hz, generates electrical output power from 29.5 $\mu$ W up to 0.57mW when driven with vibration excitation of acceleration levels of 0.01g and 0.019g respectively at resonance with external electrical load of 80k $\Omega$ . A shaker was used as a vibration source for the piezoelectric cantilever to simulate the vibration energy that can be found at many of household as well as industry appliances. An interface/power conditioning circuit with energy storage is used to accumulate the electrical energy generated from piezoelectric and then supply to power the RF transmitter node to transmit a chunks of data varies from 1 up to 10 Bytes at a certain times generated via a MCU to an RF receiving node at about 2.5m apart. The RF transmitter module was turning on for around 47 up to 102ms for each time transmitting 1 up to 10 Bytes respectively and then will be deactivated for a certain time varies from (2.5, 5, 7, and 10) seconds.

**Index Terms**—Energy Scavenging; Piezoelectric Cantilever; RF Transceivers; Vibration Energy Transformer.

## I. INTRODUCTION

The increasing of demand on miniature electronic appliances for wireless sensor network makes the maintenance/replacement issues of batteries has become a major drawback for the system overall. Especially for the Internet of Things "IoT" applications which will soon change our live style [1], due to the development of MEMS sensors and low-power wireless technologies, there will be a huge number of wireless sensors and smart objects surrounding our living space in the "IoT" era, and the huge number of wireless sensors and smart objects will create a lot of new possibilities to make our living space being smarter, green, and for better quality of lives [2]. Whereby electronic functionality is added to very large numbers of autonomous objects, maintenance-free power provision is an essential enabler. Exploring new sustainable power sources has become a popular topic, aiming to extend the lifetime and meet the requirement of miniaturized devices. Many approaches, including exploitation of light [3], temperature differences [4], and the impact/vibration energy harvesting [5][6], been implemented as power supplies.

Motivated by the amount of vibration generated via the household and the industry appliances [7], this prototype

where implemented to converts these vibration energy into an electrical charges using a piezoelectric cantilever and then accumulate the energy and store in a capacitor unit for wireless transmission. In this paper, the application is reported to have successfully transmitting a variable length of data in a range of period of time by employing the energy harvested only from vibration source. However, due to the unstable and unpredicted vibration behavior of the real vibration sources from household and the industry environments, therefore this project used electrodynamic shaker to simulate the vibration source as close as possible to the nature. A common vibration frequency and acceleration level is being used in the experiment which is matched to the piezoelectric resonant frequency in harvesting maximum electrical power.

Lately piezoelectric transduction approach has attracted a considerable research interest especially for low power application and has been proved as an favorable method in terms of energy generation compared to other methods such as electromagnetic and electrostatic [8, 9, 10]. There was being reported that, a prototype of self-powered vibration sensor produced a encouraging performance resulting for energy harvesting which is able to generate enough of energy to power up a transmitter node for a certain time [11], the proposed prototype consists of two main parts, which are: 1) the electromechanical prototype and 2) the interface/storage circuit. As mentioned previously the electromechanical part is excited by a shaker motion, and generates energy via piezoelectric cantilever. The interface/storage circuit part is designed to store a fixed amount of energy and discharge it into the next stage load circuit in each operating cycle (data transmission cycle).

This paper reports on more extensive range of vibration parameters (Frequency, acceleration, and timing), in order to investigate the operation of RF module and transmit variable which is the amount of data at variable timing. The performance resulting from a series of experiments are presented to prove the ability of the piezoelectric cantilever as an energy harvester for operating a wireless sensor node and functioning almost at the real time.

## II. EXPERIMENT SET-UP

The overall experiment setup that conducted to measure the less amount of acceleration in g-level at resonant frequency which it 290Hz that needed for a piezoelectric cantilever to

power up a RF transmitter node and send data for 2.5 m to the receiver node is presented in Figure 1. As illustrated in the figure bellow, a single piezoelectric cantilever with the dimension of length 29mm, width 13mm, and thickness of 0.6mm is mounted on the top of the electrodynamic shaker. A laser Doppler vibrometer was being used to measure the actual vibration frequency and the acceleration level of the shaker and compared with the voltage output generated by the piezoelectric cantilever.

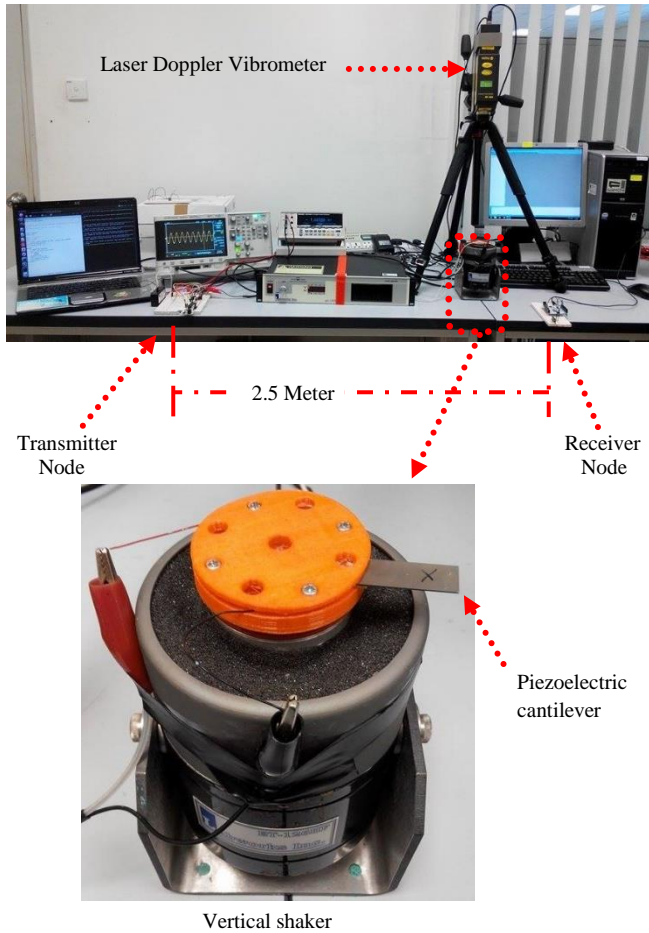

Figure 1: Experimental setup used to conduct transmission testing.

In order to investigate the performance of the piezoelectric energy harvester in powering wireless device, its output terminal is connected to the RF module. However, a microcontroller unit (MCU), ATmega328P is powered up externally, so that at the transmission node the MCU can send the blocks of data to the receiver node via the RF module using amplitude modulation "AM", with 433MHZ operating frequency, and frequency stability about  $\pm 75$ KHZ. The distance between these nodes is about 2.5 m. A  $470\mu\text{f}/25\text{V}$  capacitor is chosen as the storage component, where it will be charged by the piezoelectric energy harvester after its was being rectified via bridge rectifier, as shown in Figure 2.

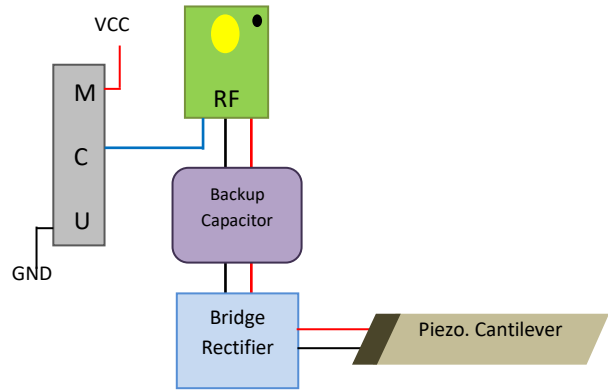
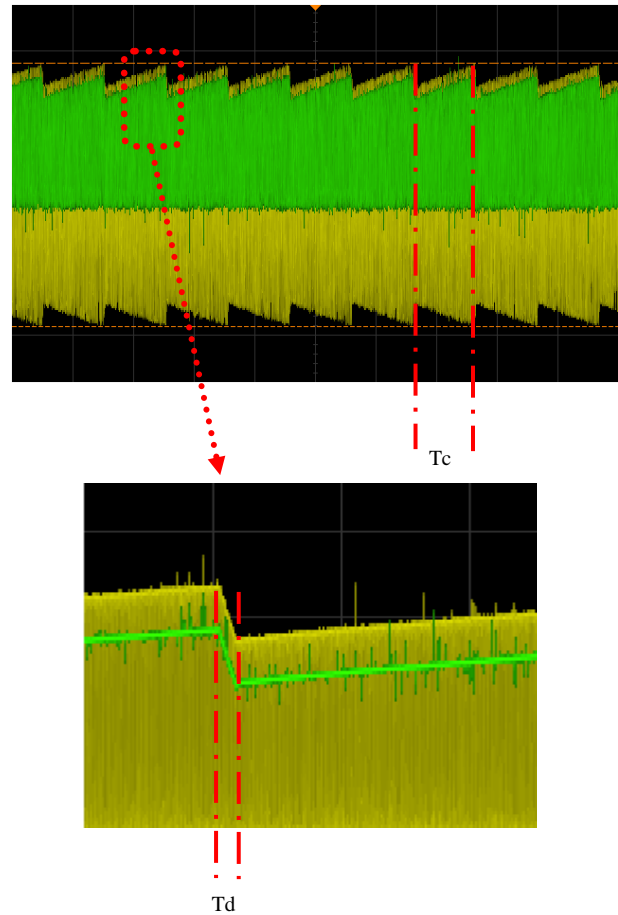

Figure 2: Block diagram of the transmitter node.

### III. EXPERIMENTAL RESULTS AND DISCUSSION

The transmitter node was set to send a variable packets sizes and then go to sleep mode for a period of time for the backup capacitor to be charged which then accumulate enough of power to operate the system for the next cycle. Figure 3 shows the capacitor cycles when it's charging up at the time when the RF transmitter is disabled and then discharge through the Transmitter to send the required data packets when it's awake.



Where:  
 Tc: Charging time.  
 Td: Discharging time.

Figure 3: Charging and discharging cycles of the backup capacitor.

Figure 4 shows that as acceleration level increases, the number of transmitted data also increases. The number of transmitted data also depends on the sleep time or the charging time of the capacitor. The charging time is set at 2.5s, 5s, 7s and 10s. It shows that at lower sleep time, higher acceleration is required to transmit higher byte of data. When sleep time is set at 2.5s, an acceleration level of about 19 mg is required to transmit 10 bytes of data compared to only 12 mg if the sleep time is increases to 10s.

There is no significant improvement when sleep time is set more than 7s as the performance of the data transmission is almost similar for sleep time set at 10s which can be shown in Figure 5.

It can be noticed that the RF transmitter module starts to broadcast one byte of data only when the minimum acceleration level is being excited to the piezoelectric energy harvester which is at 10mg. This is because the output voltage that generated by piezoelectric energy harvester at its resonant frequency and at the magnitude of 10mg is about 3V DC at open circuit "no load", which is just enough to start transmitting a byte of data.

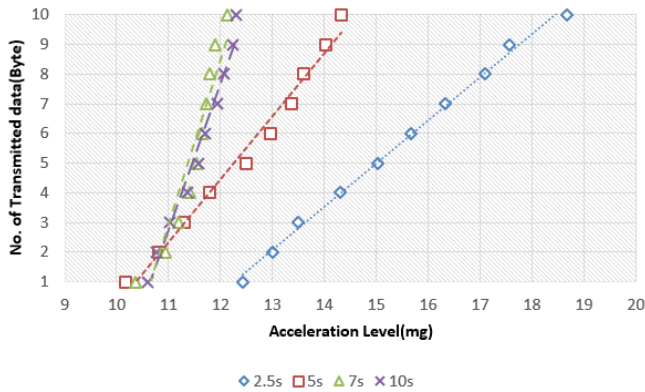

Figure 4: Data transmission performance at a range of acceleration level from 5 mg to 20 mg for different sleep time (charging time) of 2.5s, 5s, 7s and 10s.

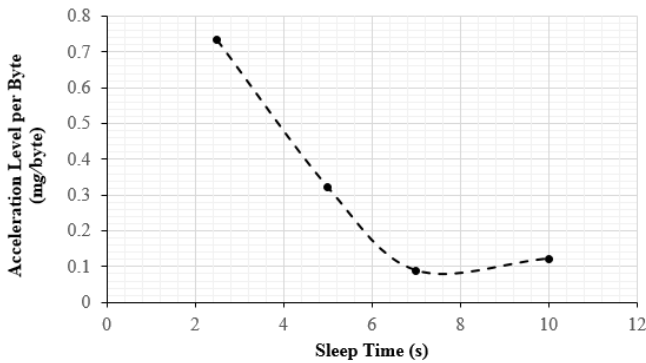

Figure 5: Acceleration level/byte over a range of sleep time (charging time) from 2s to 10s.

#### IV. CONCLUSION

A piezoelectric cantilever energy harvester powering up a RF transmitter module has been presented in this paper. Direct conversion from vibration energy into useful rectified DCV to power up a RF transmitter module. The piezoelectric cantilever was vibrating at its resonant frequency (290Hz) and it required a minimum acceleration of about 18mg to power up the RF transmitter and broadcast 10 bytes data packet at 2.5 second sleep period for about 2.5meter distance from the receiver. As most of the household appliances are generated vibration with an average acceleration level of 0.2g which it more than enough to power up the proposed system.

#### ACKNOWLEDGMENT

The authors would like to acknowledge the support of this work by the Malaysian Ministry of Science Technology and Innovation under Grant No. 06-01-14-SF0087/L00018 and UTeM internal grant PJP/2014/FKEKK(1B)/SO1293 as well as the facility support by the Faculty of Manufacturing and ASECs Research Group, CeTRI, UTeM.

#### REFERENCES

- [1] L. Atzori, A. Iera, and G. Morabito, "The Internet of Things: A survey," *Comput. Netw.*, vol. 54, no. 15, pp. 2787-2805, Oct. 2010.
- [2] P. Rashidi, D. J. Cook, L. B. Holder, and M. Schmitter-Edgecombe, "Discovering Activities to Recognize and Track in a Smart Environment," *IEEE Trans. Knowledge & Data Eng.*, vol. 23, no. 4, pp. 527-539, Apr. 2011.
- [3] O. E. Semonin et al., "Peak external photocurrent quantum efficiency exceeding 100% via MEG in a quantum dot solar cell," *Science*, vol. 334, no. 6062, pp. 1530-1533, 2011.
- [4] Y. Li, K. Buddharaju, N. Singh, G. Lo, and S. Lee, "Chip-level thermoelectric power generators based on high-density silicon nanowire array prepared with top-down CMOS technology," *IEEE Electron Device Lett.*, vol. 32, no. 5, pp. 674-676, May 2011.
- [5] J. J. Chen<sup>1</sup>, Y. C. Lien<sup>1</sup>, et al., "Self-powered Wireless Temperature Sensor with Piezoelectric Energy Harvester Fabricated with metal-MEMS Process", *Proceedings of the 10th IEEE International Conference on Nano/Micro Engineered and Molecular Systems (IEEE-NEMS 2015)*, Xi'an, China, April 7-11, 2015.
- [6] Yao Zhu, Yuanjin Zheng, et al., "An Energy Autonomous 400 MHz Active Wireless SAW Temperature Sensor Powered by Vibration Energy Harvesting", *IEEE Transactions On Circuits And Systems-I: Regular Papers*, vol. 62, no. 4, APRIL 2015.
- [7] Mohd Fauzi Bin Ab Rahman, Kok Swee Leong, "Investigation of useful ambient vibration sources for the application of energy harvesting", *IEEE Student Conference on Research and Development*, 978-1-4673-0102-2/11©2011 IEEE.
- [8] Y. Minami and E. Nakamachi, "Development of enhanced piezoelectric energy harvester induced by human motion," in *Proc. Annu. Int. Conf. IEEE Eng. Med. Biol. Soc. (EMBC)*, 2012, pp. 1627-1630.
- [9] Swee Leong, Kok, Mohd Fauzi, et al., "Hybrid Vibration Energy Harvester Based On Piezoelectric and Electromagnetic Transduction Mechanism", *2013 IEEE Conference on Clean Energy and Technology (CEAT)*, 978-1-4799-3238-2/13/©2013 IEEE.
- [10] Kok Swee Leong, Noraini Mat Ali, et al., "Investigation of Hybrid Energy Harvesting Circuits Using Piezoelectric and Electromagnetic Mechanisms", *2013 IEEE Student Conference on Research and Development (SCoReD)*, 16 -17 December 2013, Putrajaya, Malaysia, 978-1-4799-2656-5/13/©2013 IEEE.
- [11] Bong Yu Jing, Kok Swee Leong, "Demonstration of Self-Powered Accelerometer Using Piezoelectric Micro-Power Generator", *IEEE Student Conference on Research & Development 2013*, 978-1-4799-2656-5/13/©2013 IEEE.