

Evaluation of the Delay-Aware NUM-Driven Framework in an Internetwork Environment

Maciej Urbański¹, Mateusz Poszwa¹, Paweł Misiorek¹, and Dario Gallucci²

¹ Institute of Control and Information Engineering, Poznan University of Technology, Poznan, Poland

² Institute for Information Systems and Networking, University of Applied Sciences and Arts of Southern Switzerland, Manno, Switzerland

Abstract—Nowadays, due to emergence of cloud services, even the basic uses of personal computers may require the access to the Internet. In this paper modifications to Delay-Aware Network Utility Maximization System (DANUMS) are presented, which enable it to be deployed in an internetwork environment. The proposed solution consists of DANUMS and WiOptiMo systems, which cooperate by exchanging measurements of transmitted traffic in order to improve the network utility. Additionally, WiOptiMo enhances mobility by providing facilities for soft handover. Experiments presented in this paper illustrate the benefits gained from the integrated system application.

Keywords—DANUMS, Network Utility Maximization, seamless mobility, WiOptiMo, Wireless Mesh Networks.

1. Introduction

Wireless Mesh Networks (WMNs) are regarded as the suitable technology for enabling permanent Internet connection, which provide many advantages for end users as well as for network operators. Comparing to Ethernet and standard Wi-Fi networks end users can stay connected to the Internet even where wired connection is not possible or direct path for wireless signal from Access Point (AP) is blocked. Another important aspect is the fact that the WMN is self-organizing with almost no configuration needed when adding a new node is required. From the operators' point of view wireless mesh nodes are easy to be deployed and relocated, what makes the operator network extremely adaptable and expandable. In parallel, the same area coverage may be reached with smaller cost since the need for wired network backbone is reduced. The last but not the least, WMN reliability also increases with the growth of the network.

However, WMNs require more sophisticated mechanisms that assure connection stability. The presented solution responds to these needs by allowing seamless gateway switching without breaking the connection what additionally improves the stability and increases overall QoS.

It has been admitted that the attainable bandwidth in wireless networks is significantly lower than those possible in wired networks. In order to optimize their utility, a Network Utility Maximisation (NUM) framework [1] can be used. In this paper the application of the delay-aware ver-

sion of NUM framework has been evaluated, which in parallel to flows' rate, takes the delay flow characteristic into account. The presented research has been conducted within the work in the Carrier-Grade Delay-Aware Resource Management for Wireless Multi-Hop/Mesh Networks (CARMNET) project, which concentrates on implementation of mesh network in a way extending the backbone network of a telecommunications service provider [2]. As a result of work in the project, the integrated CARMNET system has been developed. The system contains the Delay-Aware Network Utility Maximization System (DANUMS) subsystem (responsible for resource management) and the WiOptiMo subsystem (responsible for mobility) as core elements [3].

The most popular scenario of wireless network use involves one or more gateways providing access to the Internet. As realization of the NUM model requires precise control over network traffic, it becomes difficult in the internetwork scenario. In particular, the DANUMS allows optimal scheduling in a wireless mesh network by taking the "utility" of flows into account [4]. The utility of a particular flow can be estimated only if relevant measurements are available. These measurements are gathered by DANUMS and disseminated by extensions of the Optimized Link State Routing (OLSR) protocol, including Urgency Reporting Messages (URMs), Queue Reporting Messages (QRMs) and Delay Reporting Messages (DRMs) described in [4]. This monitoring is only conducted within the mesh network, where each node is controlled by DANUMS software. As the flow leaves this controlled environment to reach its destination in another network, other monitoring methods have to be applied in order to ensure proper operation of DANUMS.

The paper contribution contains the description of the integration of the NUM system with mobility extensions. The integrated solution enables preservation of accurate utility estimation in the internetwork environment. The presented experiments also highlight benefits of this integration in the multi-gateway environments such as WMNs.

2. Related Work

IEEE 802.11s Mesh Networking standard [5] was developed as an extension of the IEEE 802.11 standard which

is regarded as the foundation of Wi-Fi. Internetworking is realized by Mesh Portals which serve as gateways between local mesh network and the Internet. The Mesh Portal is supported by underlying routing mechanism with selection of the most optimal route for mesh nodes including the mobile ones. As a result of Mesh Portal operation, the connection is served during roaming between networks. However, when Mesh Portal becomes unreachable the connection continuity, and thus session continuity cannot be preserved.

The dynamic topology (caused by node movement or environment change) of WMN also deteriorates the connection quality. One of the reasons of this quality decrease is the fact that once chosen gateway cannot be changed to avoid breaking the already established connections. For the sake of the connection preservation, OLSRd [6] employs additional parameter called *NatThreshold*, which favors the currently used gateway, by means of artificial lowering of measured path cost. This is the simplest solution, which, however, has its disadvantages such as routing loops occurring when the *NatThreshold* parameter value differs between hosts. The SmartGateway and MultiSmartGateway [7] extension for OLSRd allows selection of gateway in a per-flow basis by use of the IP-over-IP tunnel. Such a solution allows better allocation and partially solves the issue of changing topology. However, the long-lived connections cannot be switched to the newly selected best gateway, as this decision can be undertaken only just before connection establishment.

Authors of [8] have proposed another roaming solution for a hybrid WMN. Based on the information regarding neighbor Wireless Mesh Routers (WMRs) and their clients, the packet loss during handover could be avoided by means of shifting tunneled connections between inter-connected APs. Such a mobility solution introduces only a little delay during handover, but requires that every WMR is interconnected in a single network.

Another approach to maintain mobility which does not require any support from lower network layers is Mobile IP. In that case the mobility is managed by allowing the mobile node to use two IP addresses: a fixed home address and a care-of address that changes at each new point of attachment. This is achieved by implementing a highly sophisticated solution, which makes mobility transparent to the application layer, but is prone to DoS attacks. The Mobile IP is not suitable for the intra-domain movement, which is much more frequent than the inter-domain movement what makes it even harder to be deployed in WMN networks.

In the Spontaneous Virtual Networks architecture [9] the mobility management is moved directly to application layer. It shares features with WMNs, such as self-organization, self-configuration, and distributed architecture without need for infrastructure. However, this approach requires modification to each and every application that is supposed to gain benefits from the solution.

Finally, the important aspect of NUM is ensuring that QoS requirements are met. While DANUMS uses the DRM

extension [10] for flow monitoring in the Intranet, it is unable to collect measurements this way, when flows are forwarded to the external networks. Throughput of TCP flows and their delay can be measured by passive monitoring of ACK packets [11]. Such a solution benefits from no additional overhead, but cannot be applied for transport protocols other than TCP. For UDP flows, monitoring without overhead is not possible, but often can be realized through inspection of commonly accompanying protocols such as RTP Control Protocol (RTCP). In the presented solution, the authors have reused already available measurements provided by the WiOptiMo subsystem by implementation of the external measurement interface for the Delay-Aware Network Utility Maximization (DANUM) system [12]. The WiOptiMo measurements original purpose is to support the system QoS features, such as selection of least occupied SNAPT (the WiOptiMo proxy server) [12].

3. Applications in Real-World Scenarios

The need for CARMNET-like solutions can be observed from several perspectives. The first reason is the bigger and bigger need for permanent Internet connection caused by the growing popularity of Web applications and cloud-based services. On the other hand, many services, e.g., media streaming or Voice over IP (VoIP) calls, require uninterrupted connection during the whole session. Moreover, even unstable or slow connection may severely reduce the service utility. The integrated resource allocation optimization and mobility framework, such the CARMNET system, may be regarded as a tool addressing the above-mentioned issues.

3.1. Network Load Optimization

Let us assume two WMN users – *Alice* and *Bob* performing independent VoIP calls using Internet connection. As a result of DANUMS application, the network load may be balanced in order to achieve overall best possible quality for both of users. In order to enable optimal DANUMS operation, measurements needed for flow performance evaluation are provided by nodes constituting the mesh network as well as mobility management entity (SNAPT) located outside internal network. As a result of application of two sources of measurements, DANUMS is able to properly estimate the flow throughput and delay. It is especially important for the case of delay, since delay factor observed outside the WMN may be taken into account.

Steps

1. User Alice and Bob initiate independent VoIP calls to external network.
2. After a short period of time, the quality of Alice's connection decreases caused by the change of network conditions outside the governed WMN.

3. DANUMS is provided with information on the delay generated outside the WMN by means of WiOptiMo measurements.
4. DANUMS allocates network resources in a way increasing the perceived QoS of both connection trying to recompense the bad condition of Alice's connection.
5. Finally, in the case when Alice's connection QoS could not be compensated more network resources are provided to Bob's flow.

As a result of external delay measurements availability, DANUMS compensates the externally caused QoS decrease by reconfiguring network resource allocation in order to optimize summarized quality of both connections. In particular, when Alice does not perceive the service of satisfactory utility resources because of external delays, more resource are assigned to Bob's flow. In contrast, when the information on external delay is unknown, the Alice would perceive a decrease of call quality even if WMN would still have enough (delay/bandwidth) margin that could be used to preserve quality of both connections.

3.2. Seamless Gateway Switching

The benefit of seamless handover may be observed in the scenario, in which a user of wireless network watches a video on demand or uses another streaming service. When the user moves out of the reach of the initial gateway the connection has to be routed through a different gateway. In typical WMN without roaming technology employed, the change of a gateway implies the change of external IP address and the necessity of reestablishing the connection. Figure 1 presents comparison of the scenario of CARMNET handover solution application and the scenario of typical behaviour of WMN without seamless gateway switching. In the picture, each transport layer connection is represented by a double-headed arrow. The network layer path used for a given connection is illustrated by dashed lines between intermediate nodes. The black line denotes currently used path and connection, while the gray lines represent the previous network state. X mark is used to denote the path disruption (thus the connection disruption) which forces the use of a new network path and in consequence a new gateway. As each gateway in this scenario performs Network Address Translation (NAT), the initial connection is also disrupted, so it has to be restored as well. The bold arrow represents switching of a gateway that realizes the connection to the Internet.

Connection *a* is managed by user's application. In typical scenario, i.e., in scenario without CARMNET mobility support, this connection is abruptly broken when gateway is changed, and must be reinitialized by the application. In the case in which the proposed mobility solution is used, the connection *a* is transmitted through substitute connection *t* to the SNAPT server, and the communication can be continued as normal. Even if connection *t* is disrupted

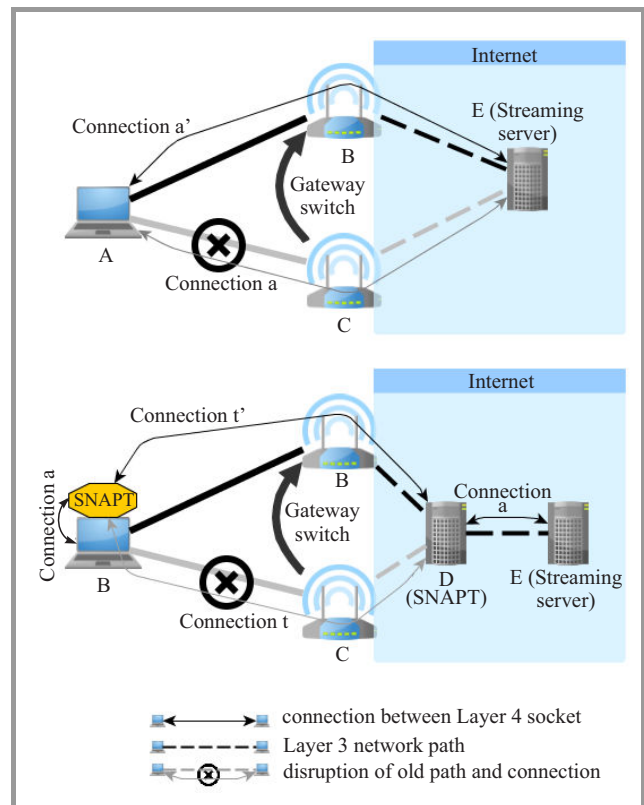

Fig. 1. Gateway switching approach comparison.

and renewed as new connection t' , it is not visible for the connection end points on hosts A and E.

Steps

1. User device – denoted as node A – uses gateway C in order to access the Internet.
2. Node A connects to most appropriate SNAPT server.
3. Due to the node movement, the conditions are changing and a new path is chosen in order to preserve the desired QoS parameters.
4. A new path through gateway B is utilized without the need to reestablish the connection, thus without disturbing user experience.

Without the mobility support (such as provided by the proposed solution) the user watching a video and changing an Internet access point at the same time will experience the interrupted or completely broken video playback (depending to the application). As a result of presented proposal application the user will be not even aware of underlying gateway switching – each TCP/IP application which does not explicitly provide the user device IP address is compatible with our approach and may benefit from it.

3.3. Application in M2M Solutions

CARMNET solutions can be applied not only in the case in which users are directly involved, but also for purposes

of Machine to Machine (M2M) communication. Devices such as vehicle trackers and path loggers and even those used for medical telemetry need to have the access to the network as often as possible. Mesh networks are particularly suitable for wireless sensors and other home automation equipment due to their ability to self-configure and repair network routes as well as the lack of the need to provide Internet access to each of the node independently. While distributed nature of the CARMNET mesh network allows easy deployment and extension of the network, the integrated WiOptiMo-based mobility solution allows to use multiple alternative Internet connection methods in a flexible way. The WiOptiMo preserves connectivity while switching between different access networks and Internet gateways. This enhancement allows the CARMNET system to provide the mobility support without additional modifications on the application layer.

4. CARMNET Framework

The idea of the CARMNET system has been proposed in [3]. The main goal of the system is to enable the WMN users to share their resources, in particular to share the Internet access. Additionally, the CARMNET vision assumes the work on integration of DANUMS with the Internet provider infrastructure – CARMNET solutions are aimed to be integrated with public wireless networks [13]. The Internet sharing functions (described in detail in [14]) are optimized as a result of the application of the utility-aware resource allocation subsystem, which allows to compare the utility of flows with different requirements with regard to end-to-end delay and throughput [4].

The implementation of the CARMNET framework requires integrated studies in several research areas including wireless network resource management, multi-criteria routing, and seamless handover. In this paper the authors have focused on integration issues concerning two CARMNET system components: DANUMS which is responsible for resource allocation, and WiOptiMo which is responsible for seamless handover functions.

4.1. DANUMS

The DANUM system [4] is aimed to maximise the overall utility of a mesh network defined as:

$$\sum_{r \in S} U_r(x_r, d_r), \quad (1)$$

where S denotes a set of flows within the network: x_r – rate of flow r , d_r – delay of flow r , U_r – the utility function of flow r . In order to do that, DANUMS prioritizes flows which gain the most utility from being served. A “virtual queue” level, defined as a product of a packet backlog and the value of the first derivative of a given flow utility function calculated for current flow performance parameters [4]. The parameters which influence the utility value include flow’s packets delivery delay and throughput

measured at destination node. Both the mentioned parameters are attained by active measurement through the use of DRM [10]. In parallel, virtual queue levels are used to perform Max-Weight Scheduling (MWS) [15] on each hop in distributed manner [4]. Additionally, the process is optimised by taking into account the 2-hop collision domain and use of the URM, which serves as more frequently broadcast abbreviation of queue levels information used to grant the right to transmit for a given node.

4.2. WiOptiMo

WiOptiMo provides decoupling between the IP address provided by the Internet Service Provider (ISP) and the IP address used to connect to a service on the Internet [12]. This feature allows a mobile node to change gateway transparently, without suffering service disruption, by means of a broker (SNAPT). However, there is still a limitation due to the architecture of Internet routing. It is not possible to change the SNAPT handling the application until its connections end.

To address the scalability problem, multiple SNAPTs can be deployed, hence allowing clients to use the least loaded available machine. The CNAPT monitors the delay to available SNAPTs, by means of passive and active monitoring of the control connection, and the bandwidth used by applications, in order to make a wise choice of the SNAPT to be used by subsequent applications. In particular, the calculated delay is used to select a SNAPT depending on the delay tolerance of the user application, while the estimated remaining throughput is used to avoid overloading a single SNAPT.

5. DANUMS and WiOptiMo Cooperation

Since DANUMS uses active probes (DRM), it cannot measure the each parameters of flows with endpoints beyond the CARMNET network. In such a case, DANUMS Loadable Kernel Module (LKM) can take into account only local queuing delay up to the Internet sharing node. Moreover, the accuracy of the rate measurement for such flows is also reduced. To remedy these problems, the DANUMS LKM allows injection of measurements from external sources through the procsfs interface [12]. This interface is represented in Linux system as a regular file allowing both read and write operations [16]. The DANUM system operates on per-flow basis, i.e., it measures the network performance parameters for each flow separately. Consequently, each line of the procsfs file corresponds to a single flow managed by DANUMS (see Fig. 2).

```
no src_address dst_address protocol delay throughput
0: 96FE299C:E624 C1AB8952:0102 06 * 120
1: 96FE299C:* C1AB8952:* * 156 *
2: C1AB8952:* 96FE299C:* * 156 *
```

Fig. 2. DANUMS LKM procsfs interface.

However, DANUMS allows supplying information regarding routes as well. WiOptiMo monitors the route between CNAPT and a SNAPT with a separate control traffic flow. Information gathered in this process can be passed to the DANUMS LKM by writing it to the `procf` file as flow measurement lines with reduced flow identifier to the source and destination IP addresses only. As a result, WiOptiMo (via the `procf` interface) can provide measurements necessary for DANUMS to optimize its operation. In particular, the delay between a gateway and a SNAPT measured by CNAPT can be added to the delay of flows destined to that SNAPT and leaving the CARMNET network through the used gateway, in order to enhance the accuracy of measurements used in utility calculation. The CNAPT on the source node can also overwrite throughput measurements for flows which it is responsible for, in order to take into account the losses experienced outside the CARMNET network.

In standard use cases of wireless mesh network application (i.e., without the specific handover support), only Internet gateways have public IP addresses and use NAT to share this connection settings. If the Internet gateway is changed, the already established connections will break due to the public IP change. The most common practice is to preserve once chosen gateway regardless of changing conditions for routes. This is not applicable to connections established with help of CNAPT, as WiOptiMo solution allows public IP to be changed seamlessly. As a consequence, the best available route to the selected SNAPT can be used always, regardless of the currently selected gateway. This feature can be implemented without modifying the OLSR protocol and software implementation on nodes by simply introducing “virtual” host into Topology Control OLSR messages representing a connection between Internet sharing node and SNAPT as a link state information.

6. Experimentation Scenarios and Setup

The presented experimentation scenarios represent typical uses of the CARMNET network. Both experiments use a simple WMN topology presented in Fig. 3. Internet-sharing nodes B and C allow other nodes applying DANUM-based scheduling policy to access the external network.

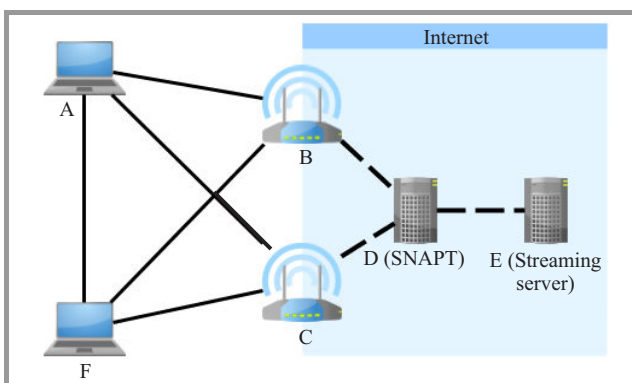

Fig. 3. Basic network topology used in the experiments.

Gateway nodes B and C perform NAT to allow nodes from WMN to connect to external hosts without the need for external IP address. The CNAPT clients, which goal is to enable mobility for chosen flows, are present on every wireless node (A, B, C and F). SNAPT – the server-side implementation of WiOptiMo – is hosted on server D. Server E hosts services, which can be accessed by client nodes A and F. When mobility support is used, client nodes connect to server E through SNAPT hosted on D.

6.1. *wnPUT Testbed*

The presented experiments are realized with help of physical testbed deployed in Poznan University of Technology campus – the *wnPUT* testbed [14]. Every node is equipped with wireless and wired network interface cards for serving experimental and out-of-band traffic, respectively. Testbed software consists of management framework and Debian-based Linux distribution allowing for the remote disk-less boot and control of testbed nodes. Main task of the software framework is to ease the process of experimentation by allowing conduction of repeatable experiments on the commonly available hardware platforms. With *wnPUT* testbed each experiment can be described in the already established DES-Cript [17] format and executed without further intervention. For additional features such as remote power-cycling nodes in-house extensions of the experiment description syntax is used, preserving compatibility with DES-Testbed [17] at the same time. For testing in *wnPUT* testbed the DANUMS has been implemented as LKM (responsible for scheduling and resource allocation) and a plugin for OLSRd – the most widely adopted implementation of OLSR protocol (responsible for routing and measurement support).

For each experiment a physical testbed nodes was used which were interconnected by ad-hoc wireless network. The Internet connection was emulated with help of NetEm, simulating both delay and loss [18] commonly associated with Internet connection. In order to ensure packet backlog accumulation on gateway nodes, the Linux traffic control network subsystem was used to limit the available bandwidth of interfaces connected to the external network. This modification was required to illustrate common case, where Internet connection bandwidth is lower, than the one available in the local, even wireless, network.

6.2. *The External Delay Influence Analysis*

In the first experimentation scenario nodes A and F connect to the service provider E. Both connections route through SNAPT server hosted on D. SNAPT server is chosen in a way ensuring negligible delay to host E. The flow f_{A-E} is routed through the gateway B, whereas the flow f_{F-E} is routed through the gateway C. The gateways use measurements provided by WiOptiMo, which reports approximately 100 ms of delay between B and D, and approximately 20 ms of delay between C and D. Both delays were artificially enforced in order to simulate the fact that the

gateways use different ISPs. UDP flows f_{A-E} and f_{F-E} experience different delays along the path due to operation of the DANUM scheduling and uncontrolled external network environment. For the topology stability, the OLSR standard-compliant hop-count metric was used. The experiment has been performed in two variants differing in the order of starting the flows. In the DANUM subsystem, the following UDP-based utility function [4] has been assigned to both flows:

$$U_{UDP}(x, d) = \frac{w}{1 + e^{b(d-t_d)}}, \quad (2)$$

where $w = 10^6$ controls maximal utility, $b = 0.0375$ controls the slope of sigmoid function, and $t_d = 300$ specifies a delay threshold in which the derivative is minimal, hence the price is maximal. The delay is measured in milliseconds.

6.3. Seamless NAT Gateway Switching

In the second experimentation scenario the WiOptiMo solution is used to reduce influence of gateway switching in WMN. At $t = 0$ a single TCP connection is initiated between node A and service provider E using CNAPT-SNAPT software. This connection uses all available bandwidth and adapts accordingly to TCP agent flow and congestion control. At $t = 0$, C is the chosen Internet gateway of node A due to lower delay. In the 20th second of experiment ($t = 20$), the quality of path decreases by introduction of 5% loss on link A-C simulating node movement or external interference.

For execution of flows both with and without support of WiOptiMo solution the virtual node in OLSR topology could be used. This solution would allow independent gateway choice for both flows served in the standard way as well as for the case of WiOptiMo mobility support. For the sake of simplicity of implementation we have opted to transmit the information about the path to SNAPT by Host and Network Association (HNA) messages – same way that Internet access is broadcast by Internet sharing nodes. To change default gateway switching behavior the *NatThreshold* parameter of OLSRd is disabled on each node, as the gateway-preserving mechanism is not needed when the WiOptiMo solution is used. To detect and take the link quality changes into consideration, the Expected Transmission Count (ETX) route metric is used [19]. Using this metric OLSRd is able to choose paths with overall lower loss rate allowing higher throughput.

7. Experimentation Results

7.1. The External Delay Influence Analysis

Results of the experiment described in Subsection 6.2 show that the flow with lower delay suppresses the flow with higher delay regardless of the order of starting the flows (see Figs. 4 and 5). At the beginning of the experiment, there is only one flow in the network and, because

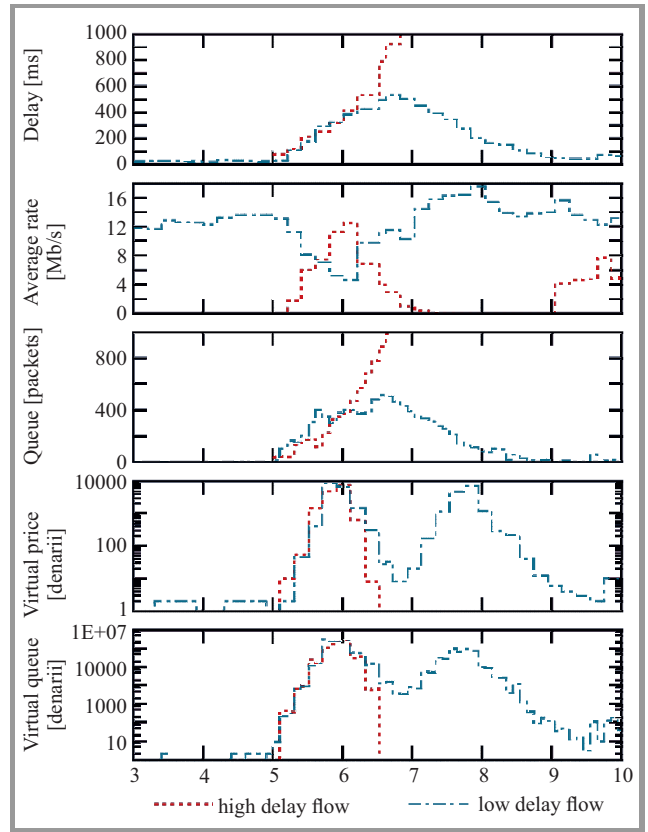

Fig. 4. Influence of external measurements on flow behavior. A flow with lower external delay has been started first.

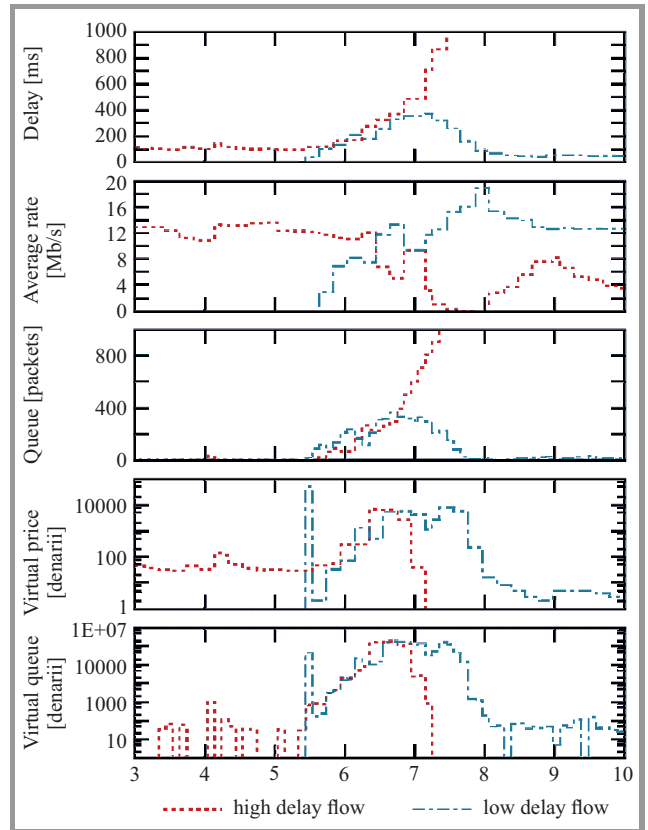

Fig. 5. Influence of external measurements on flow behavior. A flow with lower external delay has been started second.

of lack of competition, it experiences no delay besides the amount caused by external network conditions. When the second flow starts, both flows begin to compete for the bandwidth. The competition in this case (two UDP flows) consists of two phases. In the first phase the delay of both flows does not exceed the threshold of 300 ms. In this phase, the virtual price increases with the grow of delay. The second phase begins when the delay of one of the flows exceeds the threshold. Starting at this moment the price of this flow drops with the rise of its delay. This behavior is a consequence of the application of utility function used for UDP flows (see Eq. 2) for the DANUMS utility calculation.

In the first phase, packets accumulate in both flows' queues, because the summarized flows rate exceeds the available bandwidth. As a consequence, the flows' delays increase, what causes the rise of the flows' price. Eventually, this situation leads to rising virtual queue levels. Basically, DANUMS tries to equalise virtual queues, which are calculated as a product of packet queue length and virtual price. Packets belonging to a flow with the highest virtual queue are sent first. Sending packets from flow's queue lowers the flow's virtual queue, but also causes the increase of the virtual queue level at the other flow. As a result, packets of both flows are sent alternately at insufficiently high rate. The situation changes when the delay of one of the flows eventually exceeds its threshold and the second phase begins.

At the beginning of the second phase, the price of one of the flows is maximal. This means that in order to achieve the same level of virtual queue, that flow has to accumulate more packets. However, the higher is the length of packet queue, the higher is the queuing delay. Further increase of delay causes the price to drop and, despite accumulating more packets, the flow becomes unable to compete for resources. Eventually, its price and, consequently, its virtual queue level drops to zero and its transmission terminates. In parallel, the second flow "wins" the competition and acquires bandwidth previously used by the "losing" flow. Superfluous bandwidth is used to transmit overdue packets of the winning flow, because it still has non-zero price and virtual queue. When the packet queue of the winning flow drops to zero, the flow rate stabilises and the remaining bandwidth is used to transmit packets of remaining flows.

As explained above, a flow "wins", if it has lower delay than other flows for the same value of virtual queue at the end of the first phase. Since one of the flows has lower delay, it tends to have higher packet queue level in order to compensate the price difference. Having a higher packet queue means that the price can be lower while still maintaining sufficient virtual queue level. In the first phase, the lower price translates to lower delay, therefore flows with lower delay are more likely to suppress other flows. It is worth to note, however, that external network conditions have the strongest influence on flows' delays. Without information about delay outside the wireless network controlled by the

CARMNET system, flows would perceive very similar delays and determining the winning flow would be left to chance. This behavior is not desirable and shows importance of external measurements.

7.2. Seamless NAT Gateway Switching Experiment Results

Results of the gateway switching experiment (performed according to the scenario described in Subsection 6.3), are shown in Fig. 7. The topology evolution caused by the change of environment conditions is illustrated in Figs. 6a and 6b.

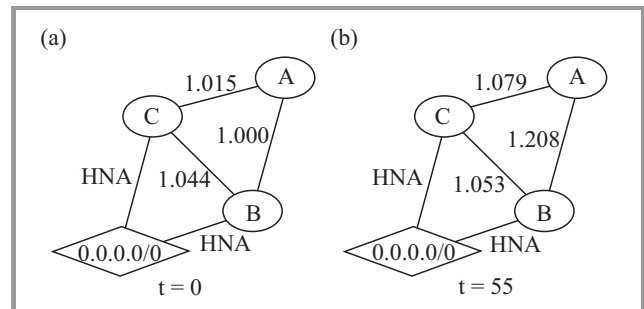

Fig. 6. Network topology with ETX metric values (as perceived by the OLSR daemon) on node A during the gateway switching experiment: (a) before and (b) after the change of environment conditions.

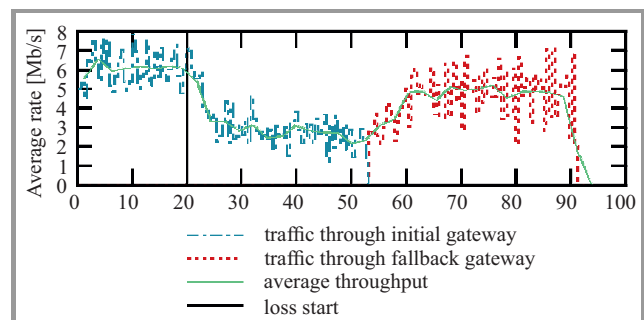

Fig. 7. Seamless gateway switching experiment results.

In the experiment execution, node A initially chooses node B as its gateway, accordingly to lower path cost measured by ETX metric (Fig. 6a). The TCP connection between nodes A and E is established with help of the WiOptiMo subsystem. As can be seen in Fig. 7, at $t = 20$, the degradation of the link quality has caused a decrease in the utility of flows. The higher loss ratio combined with the TCP congestion algorithm operation results with much lower throughput (around 3 Mb/s) then the one observed previously (6 Mb/s). Due to the implementation of the hysteresis-based solution in the OLSRd link quality calculation algorithm, it has taken some time for this drastic change to be reflected in path metric. Eventually, at $t \approx 53$, the OLSR daemon on node A decides to select the alternative path leading through another gateway (node C) to the service provider H (see Fig. 6b).

For the case of service without the mobility support, any connection from A to the external network through NAT-performing gateway would be severed without warning. What is more, the gateway change may occur late or even not at all (e.g., as a result of the *NatThreshold* application).

In contrast, as in this experiment we use WiOptiMo mobility solution, the connections remain intact even when gateway changes. Moreover, a new path allows regaining at least part of previously attained throughput (over 5 Mb/s).

8. Conclusions and Future Work

Integration of DANUMS and WiOptiMo solutions provides better resilience for topology and link-quality changes in multi-gateway mesh networks. Additional flow measurements provided to DANUMS allow improvements in DANUMS operation, in particular help to achieve the DANUMS main goal, i.e., optimization of overall network utility in the case when the flows transmitted to the external network such as the Internet are served.

Future work includes implementation of techniques allowing per-flow and preemptive transitions between routing paths. Loose source routing could be used (at least in the transitional phase) to preemptively change a gateway by WiOptiMo, using information gathered by the OLSR daemon. This task could also be realized by using approach already implemented in existing OLSRd extension – the Multi Smart Gateway – which creates IP-over-IP tunnels between gateways and wireless client [7]. Such a solution could preserve compatibility with routers which treat IP Source Routing header as a second-class citizen due to security and implementation issues.

Acknowledgement

This work was partly supported by a grant CARMNET financed under the Polish-Swiss Research Programme by Switzerland through the Swiss Contribution to the enlarged European Union (PSPB-146/2010, CARMNET), and by Poznan University of Technology under grant 04/45/DSPB/0122.

References

- [1] F. Kelly, “Charging and rate control for elastic traffic”, *Eur. Trans. Telecommun.*, vol. 8, no. 1, pp. 33–37, 1997.
- [2] “CARMNET Project” [Online]. Available: <http://www.carmnet.eu>
- [3] M. Gła̧bowski and A. Szwabe, “Carrier-grade Internet access sharing in wireless mesh networks: the vision of the CARMNET Project”, in *9th Adv. Int. Conf. Telecommun. AICT 2013*, Rome, Italy, 2013.
- [4] A. Szwabe, P. Misiorek, and P. Walkowiak, “Delay-aware NUM system for wireless multi-hop networks”, in *Proc. 11th Eur. Wirel. 2011*, Vienna, Austria, 2011, pp. 530–537.
- [5] J. Camp and E. W. Knightly, “The IEEE 802.11s extended service set mesh networking standard”, *IEEE Commun. Mag.*, vol. 46, no. 8, pp. 120–126, 2008.

- [6] “An ad-hoc wireless mesh routing daemon”, 2009 [Online]. Available: <http://www.olsr.org>
- [7] F. Huberts, “Mitigation of breaking connections”, 2013 [Online]. Available: <http://www.olsr.org/files/multi-smart-gateway.pdf>
- [8] L. Couto, J. P. Barraca, S. Sargento, and R. L. Aguiar, “Fastm in WMN: a fast mobility support extension for wireless mesh networks”, in *Proc. 2nd Int. Conf. Advan. Mesh Netw. MESH 2009*, Athens, Greece, 2009, pp. 90–96.
- [9] R. Bless, C. Mayer, C. Hübsch, and O. Waldhorst, “Spovnet: an architecture for easy creation and deployment of service overlays”, *River Publish.*, vol. 6, pp. 23–47, 2011.
- [10] A. Szwabe, P. Misiorek, and P. Walkowiak, “DANUM system for single-hop wireless mesh networks”, in *Proc. Int. Conf. Future Inform. Technol. ICFIT 2010*, Changsha, China, 2010, vol. 1, pp. 365–369.
- [11] S. Jaiswal, G. Iannaccone, C. Diot, J. Kurose, and D. Towsley, “Inferring TCP connection characteristics through passive measurements”, in *Proc. 23rd ann. Joint Conf. IEEE Comp. Commun. Soc. IEEE INFOCOM 2004*, Hong Kong, 2004, pp. 1582–1592.
- [12] S. Vanini, D. Gallucci, S. G. Cremonese, and A. Szwabe, “A delay-aware NUM-driven framework with terminal-based mobility support for heterogeneous wireless multi-hop networks”, in *Inform. Commun. Technol. Forum IOCTF 2013*, Poznan, Poland, 2013.
- [13] P. Walkowiak, R. Szalski, S. Vanini, and A. Walt, “Integrating CARMNET system with public wireless networks”, *Proc. 13th Int. Conf. Netw. ICN 2014*, Nice, France, 2014, pp. 172–177.
- [14] P. Misiorek, P. Walkowiak, S. Karlik, and S. Vanini, “SIP-based AAA in delay-aware NUM-oriented wireless mesh networks”, *Image Proces. Commun.* vol. 18, no. 4, pp. 44–58, 2014.
- [15] L. Tassiulas and A. Ephremides, “Stability properties of constrained queueing systems and scheduling for maximum throughput in multihop radio networks”, *IEEE Trans. Autom. Contr.*, vol. 37, no. 12, pp. 1936–1949, 1992.
- [16] B. Wang, B. Wang, and Q. Xiong, “The comparison of communication methods between user and Kernel space in embedded Linux”, in *Proc. Int. Conf. Computat. Problem-Solv. ICCP 2010*, Lijiang, China, 2010, pp. 234–237.
- [17] M. Güneş, F. Juraschek, B. Glywis, and O. Watteroth, “DESCRIPT – a domain specific Language for network experiment descriptions”, in *Next Generation Wireless Systems 2009 – Proceedings*, N. Chilamkurti, Ed. Lambert Academic Publishing, 2010.
- [18] M. Becke, T. Dreiholz, E. P. Rathgeb, and J. Formann, “Link emulation on the data link layer in a Linux-based future internet testbed environment”, in *Proc. 10th Int. Conf. Netw. ICN 2011*, St. Maarten, The Netherlands Antilles, 2011, pp. 92–98.
- [19] D. S. De Couto, D. Aguayo, J. Bicket, and R. Morris, “A high-throughput path metric for multi-hop wireless routing”, *Wirel. Netw.*, vol. 11, no. 4, pp. 419–434, 2005.

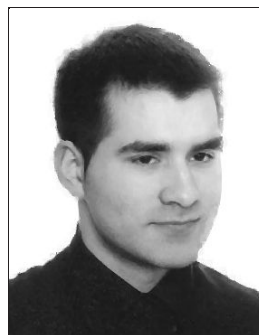

Maciej Urbański in 2010-2011 was involved in the EU-FP7-ICT project OPNEX. Since 2012 he works in the CARMNET project. Currently he holds a position of the senior technical assistant in Institute of Control and Information Engineering at Electrical Engineering Faculty of Poznan University of Technology. His research

interests are located in the areas of distributed systems, community wireless networks as well as topics related to a concept of the Internet of Things.

E-mail: maciej.urbanski@put.poznan.pl
 Institute of Control and Information Engineering
 Poznan University of Technology,
 M. Sklodowskiej-Curie Sq. 5
 60-965 Poznan, Poland



Mateusz Poszwa received his B.Sc. degree in 2013 from Poznan University of Technology. He participates in the CARMNET project as a member of research team responsible for design and implementation of the CARMNET system. Currently he is continuing his studies in pursuit of the M.Sc. degree. His professional interests focus

on embedded systems, wireless networks and machine learning.

E-mail: mateusz.poszwa@student.put.poznan.pl
 Institute of Control and Information Engineering
 Poznan University of Technology
 M. Sklodowskiej-Curie Sq. 5
 60-965 Poznan, Poland



Paweł Misiorek received his M.Sc. (2002) and Ph.D. (2008) degrees from Adam Mickiewicz University of Poznan in Computer Science and Mathematics, respectively. Since 2008 he is employed in Poznan University of Technology. In 2008–2011 he was involved in work for the EU-FP7-ICT project

OPNEX. Currently, he is an assistant professor in Institute of Control and Information Engineering at Electrical

Engineering Faculty of Poznan University of Technology. He conducts research in the areas of statistical machine learning and wireless networking. His networking-related interests include experimental studies on wireless multi-hop networks with focus on an application of the NUM approach and probabilistic methods for designing of network control algorithms.

E-mail: pawel.misiorek@put.poznan.pl
 Institute of Control and Information Engineering
 Poznan University of Technology
 M. Sklodowskiej-Curie Sq. 5
 60-965 Poznan, Poland



Dario Gallucci is a researcher at University of Applied Science – SUPSI in Ticino, Switzerland. He has received his M.Sc. degree (2006) in Telecommunication Engineering and his Ph.D. degree (2010) in Computer Science from Politecnico di Torino, Italy. His current research interests focus on improving Mobility Support

over heterogeneous networks and Quality of Service of multimedia transmissions over wireless and mobile networks, with a special interest in wireless mesh networks. He has also experience in solutions for wireless-based indoor positioning, network design for IP convergence, video streaming over peer-to-peer networks and distributed video editing.

E-mail: dario.gallucci@supsi.ch
 Institute for Information Systems and Networking
 University of Applied Sciences and Arts
 of Southern Switzerland
 Via Pobietta 11
 6928 Manno, Switzerland