

# Wind Farms Influence on Radiocommunication Systems Operating in the VHF and UHF Bands

Krzysztof Bronk, Adam Lipka, Rafał Niski, and Błażej Wereszko

*National Institute of Telecommunications, Wireless Systems and Networks Department, Gdańsk, Poland*

**Abstract**—The following paper discusses several aspects connected with the wind farms' impact on radiocommunication systems. The first part of this article is filled with the analysis of the ITU-R BT.1893 model, which was originally created for the analysis of the interaction between the wind turbines and digital TV receivers in the UHF band. A measurement campaign carried out by the authors confirmed that this model is also applicable for the lower, maritime VHF band. Utilizing the software implementation of this model, the authors conducted a thorough simulation analysis of the wind turbines' influence on radio systems working in both VHF and UHF bands. The results of these simulations are presented and discussed in the second part of the paper.

**Keywords**—*propagation, turbines, wind energy, wind farms.*

## 1. Introduction

In recent years, a significant growth of interest in renewable energy sources – including wind energy – has become a global trend. The statistics indicate that the number of power plants (usually referred to as wind farms) is growing constantly, as is the total power offered by these installations. At the end of 2013, the total (global) wind power capacity was 318 GW, and Europe accounted for 38% of that value [1].

The demand for the installation and exploitation of wind turbines brings about the need to analyze and assess how these objects actually interact and affect their environment. It is commonly known that wind farms – and their major components, i.e. wind turbines – despite the undeniable benefits they offer – can also be a source of numerous negative and harmful effects, such as noise increase, threat to birds, etc. In this context, it might be interesting to discuss the influence of the wind farm on radiocommunication systems. The potential interaction between them is mainly caused by the material the turbines are made of (composite/metal) and by the large dimensions of such constructions (both the height of masts as well as rotor's ranges might be greater than 100 m). As a result, a wind turbine constitutes a substantial obstacle that could not only attenuate the radio signal but also reflect it. Out of these two phenomena, the latter seems to be of particular importance, but for many reasons it is also rather difficult to analyze. It might be surprising but

the knowledge about the interactions between the wind turbines and radiocommunication systems is rather limited, as is the number of the subject literature (see [2]–[4]). Furthermore, there are very few mathematical models that facilitate a formal description of these issues. One of those is contained in the ITU-R Recommendation BT.1893 [5], but it generally concerns only the negative effects that can be caused by the farms to the digital TV systems operating in the UHF band<sup>1</sup>.

In 2013, the National Institute of Telecommunications (NIT) carried out an extensive study dedicated to the analysis of the wind farm influence on selected radio systems, with a particular attention paid to the systems operating in the maritime VHF band (156–162 MHz). This article presents and discusses several aspects of that research. The organization of the remainder of the paper is as follows. In Section 2, the ITU-R BT.1893 mathematical model, which allows to calculate the power of signals reflected from the wind farm, is introduced. The major assumptions formulas and definitions relevant to the model are presented, including the Unwanted Field Strength (UFSR) parameter. However, as it was mentioned before, the ITU-R BT.1893 model is theoretically only applicable to the UHF TV band. In order to verify whether it could also be suitable for the maritime VHF band, it was necessary to conduct a measurement campaign at actual wind farm sites and to compare its results with the theoretical data resulting from the model. At the end of 2013, such a campaign did indeed take place, and it is discussed in Section 3. In this part, the authors explain the overall measurements methodology, describe the equipment set and finally present the obtained results. The analysis of these results clearly indicates that the discussed mathematical model can indeed be applied for the VHF band. Given the above, the authors developed a software implementation of this model and used it to conduct a wide simulation analysis of the wind farms' influence on radio systems operating in both VHF and UHF bands. The methodology, including the concept of the equivalent (substitute) EIRP power, and the results of this comparative analysis are thoroughly discussed in Section 4. Finally, Section 5 concludes the whole article.

<sup>1</sup> The ITU-R has also issued a recommendation [6] dealing with wind farms' influence on analogue TV.

## 2. The ITU-R BT.1893 Model

The ITU-R BT.1893 recommendation was originally created to provide evaluation methods of the impairments caused to digital television reception (UHF band) by wind turbines. The model contained in the recommendation facilitates a mathematical description of the primary propagation mechanism occurring at the wind turbines' sites, i.e., the radio signal reflection from the wind turbine blades. In the following paragraph, the major assumptions of this model will be presented and discussed.

Let us now assume the arrangement of the transmitter, receiver and wind turbine as depicted in Fig. 1.

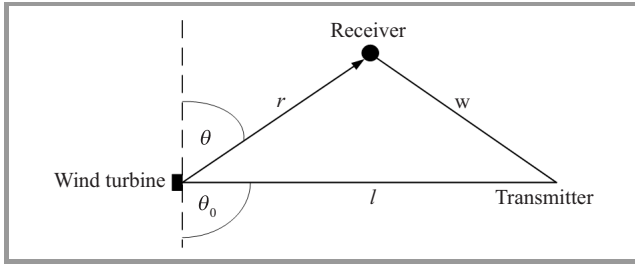

**Fig. 1.** The arrangement of transmitter, receiver and the wind turbine.

Under the assumption that the distance between the receiver and the wind turbine is  $r$ , the scattering coefficient  $\rho$ , which includes the free-space loss for the path between the turbine and the receiver can be expressed as follows:

$$\rho = \frac{A}{\lambda r} g(\theta), \quad (1)$$

where

$$g(\theta) = \text{sinc}^2 \left[ \frac{S}{\lambda} (\cos \theta - \cos \theta_0) \right] \sin \theta, \quad (2)$$

and

$$\text{sinc}(x) = \frac{\sin(\pi x)}{\pi x},$$

- A – total area of the turbine blades [m<sup>2</sup>],
- S – mean width of the blade [m],
- $\lambda$  – radio signal wavelength [m],
- $r$  – the distance between the wind turbine and the receiver [m],
- $\theta$  – the angle between the receive direction and the plane of the rotor, i.e. the angle of the signal reflected (scattered) from the blades [°],
- $\theta_0$  – the angle between the transmit direction and the plane of the rotor, i.e., the angle of the incident signal at the blades [°].

The  $g(\theta)$  function has values in the range of  $-1 \dots 1$ .

It might be stated the coefficient  $\rho$  in Eq. (1) is an indicator of the amount of the incident signal that will be reflected from the blades towards the receiver. It should be underlined the above formula was defined under the assumption the wind turbine blades are approximately triangular and

metallic. However, nowadays, a blade is typically made of fiberglass or another composite material, which results in the  $\rho$  coefficient being 6 to 10 dB lower than in the case of metallic blades. Consequently, if the analysis is conducted for the composite material blades, the scattering coefficient resulting from Eq. (1) should always be adjusted (decreased) accordingly.

The value of the  $\rho$  coefficient is maximum when the transmitter, receiver and wind turbine are all in the same line, and when additionally this line is perpendicular (normal) to the rotor's plane. In such a case:

$$\rho = \rho_{\max} = \frac{A}{\lambda r}. \quad (3)$$

Let us now define the Field Strength at the Wind Turbine (FSWT) parameter as the strength of the signal directly at the wind turbine location:

$$\text{FSWT} = \text{EIRP} - L_l, \quad (4)$$

where EIRP – equivalent isotropical radiated power of the transmitter [dBm],  $L_l$  – propagation loss (attenuation) on the path between the transmitter and wind turbine (length  $l$ ) [dB].

If the length of the path between the receiver and wind turbine is  $r$ , then the unwanted signal power, i.e., the power of the signal that propagates from the transmitter to the receiver due to reflection from the turbine blades, can be calculated as:

$$\text{UFSR} = \text{FSWT} + 20 \log \rho. \quad (5)$$

The Unwanted Field Strength (UFSR) is a key parameter which allows to analyze the wind farm as the source of a secondary radiation.

## 3. Model Verification Measurement

### 3.1. The Measurement's Methodology

As it was mentioned before, the ITU-R BT.1893 model was originally intended for the analysis of the wind farms' impact on the UHF digital television systems. For the purpose of the works conducted by the NIT it was necessary to assess whether this model can also be applied to the systems operating in the maritime VHF band. To do so, an extensive measurement campaign was organized in late 2013 which covered several selected wind farms located in the northern and central Poland.

The general methodology of the measurements was as follows: at the transmitter side, a 161 MHz impulse<sup>2</sup> was generated and repeated every 80  $\mu$ s. This impulse, whose width

<sup>2</sup> 161 MHz is a frequency that belongs to the maritime VHF band. This particular value was selected and used during the measurements in order to avoid spurious emissions of the spectrum analyzer which would be inevitable at 160 MHz. On the other hand, during the simulations (Section 4), the value of 160 MHz was utilized.

was  $8 \mu\text{s}$ , was then transmitted in the wind turbine's direction. At the receiver side, the levels of two signals were measured: (a) the level of the direct signal, referred to as the Wanted Field Strength (FSR) in the ITU-R BT.1893 recommendation and (b) the level of the signal reflected from the turbine (UFSR). The results obtained this way – particularly the UFSR – were then compared with the theoretical data resulting from the model.

The simplified method of these measurements can be presented as in Fig. 2.

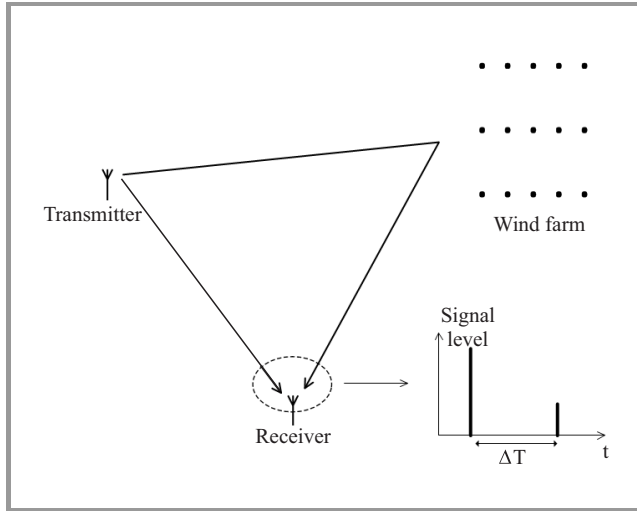

Fig. 2. The general concept of the measurements.

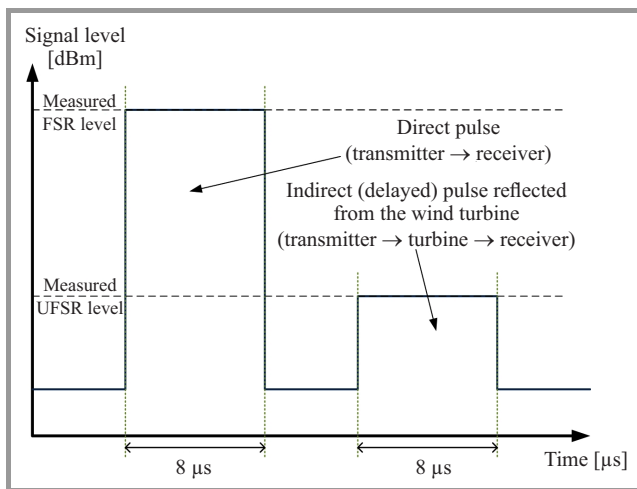

Fig. 3. The concept of the measurements using the spectrum analyzer Zero Span function.

Generally, all the measurements were conducted in time domain<sup>3</sup> – using the Zero Span feature of the spectrum analyzer (see Fig. 3) – for both types of antenna polarization (vertical and horizontal). Since the purpose of this analysis was to identify the strongest reflected signal (the worst case), the measurements had to be repeated several times for every location of the transmitting/receiving sets. It was

<sup>3</sup> The frequency domain measurements were only for the comparison.

due to the fact the wind turbines' rotors were obviously rotating most of the time, so the maximum level varied as the measurements went on, and furthermore the received signal comprised components reflected from many turbines (a precise determination of the number of turbines the particular signal reflected from was only possible in a few cases). Due to the assumption that only the worst-case scenario is analyzed, the vast majority of the measurements were taken when the rotors' planes were approximately normal to the direction of the transmission/reception.

### 3.2. The Measurement Equipment

The measurements as described above were conducted using the professional, calibrated equipment depicted in Fig. 4. The transmitting set was composed of the following parts:

- signal generator (250 kHz–4 GHz) – Agilent E4433B with the pulse modulation capability,
- transmitting directional antenna – AH Systems Biological Antenna SAS-521F-7 (25 MHz–7 GHz),
- power amplifier – Popek Elektronik type PEA02-1-40,
- two measurement cables – 3-meters cable RG-214 N-N.

The calibrating set consisted of the following parts:

- spectrum analyzer – Anritsu MS2721B with *High Accuracy Power Meter* option,
- power sensor – Anritsu PSN50,
- power attenuator – Tenuline 30 dB for frequencies up to 500 MHz.

And finally, the receiving set comprised the following parts:

- spectrum analyzer – MS2721B with the appropriate options,
- set of dipole antennas – Emco Model 3121C (28 MHz–1 GHz),
- measurement cable – 3-meters cable Huber+Suhner ST18A/11N468/3000MM.

Both measurement stands were mobile (installed in cars) and they were powered using independent supplies: a voltage converter Volt IPS-5000 2500 W 12 V DC → 230 V AC (in case of the receiving set) and an inverter generator Adler AD-2800 (in case of the transmitting set).

As it was previously mentioned, the transmitted pulse signal width was  $8 \mu\text{s}$  and it was repeated every  $80 \mu\text{s}$ . The assumed value of the pulse width resulted directly from the capability of the Agilent E4433B generator. The frequency of the pulse signal was 161 MHz and the signal level at the antenna input was 40 W (46 dBm)<sup>4</sup>. When

<sup>4</sup> To provide the desired value of the signal power at the output of the power amplifier, it was necessary to use a calibrating set (see Fig. 4c).

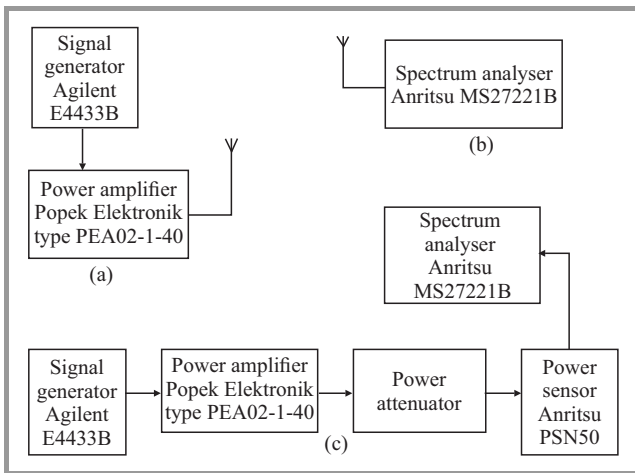

Fig. 4. Schematic representation of the measurement set: (a) transmitting, (b) receiving, (c) calibrating.

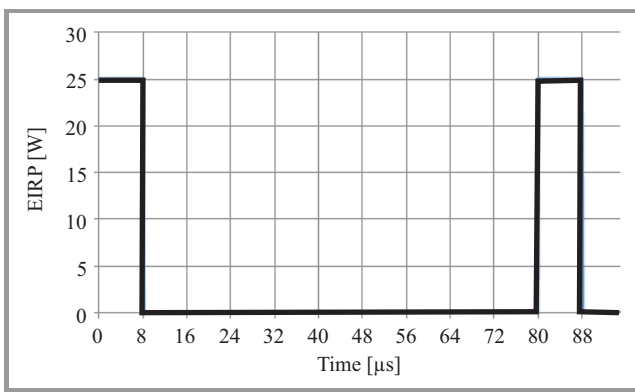

Fig. 5. The visualization of the transmitted pulse signal.

taking into account the antenna gain ( $-2$  dBi for 161 MHz) the EIRP power of the pulse was about 25 W (44 dBm). The characteristic of the transmitted signal is depicted in Fig. 5.

## 4. The Measurement Results

Since the number of the measurement scenarios executed during the campaign was relatively large, it is not possible to present and discuss all the results in this paper. For this reason, in the following part, the authors will only include the detailed result obtained for one of the farm (one measurement scenario), and compare it with the theoretical values resulting from the model. The measurement results obtained for other scenarios will be gathered in a table. On the basis of these data, the final conclusions on the ITU-R BT.1893 model verification will be drawn.

As the information included in the previous paragraphs indicate, in order to employ the presented model, it is first necessary to know several parameters of the wind turbines, most notably the total area of the blades ( $A$ ) and the mean width of a single blade ( $S$ ). The manufacturers generally publish the technical specifications of turbines but in most

cases these information are not sufficient to be used directly in this model. Consequently, it is often necessary to employ other formulas and simplifications to calculate the required input data. In particular, the total area of the blades might be estimated using the so-called  $Q$  coefficient (Quality number), which is a ratio of the rotor swept area to the total area of the material needed to build this rotor. In case of a typical, 3-bladed, horizontal axis rotor, the  $Q$  coefficient is assumed to be 31.25 [7], [8]. The approximate total area of three blades,  $A$ , can now be calculated using the following expression [7], [8]:

$$A \approx \frac{P}{Q} \approx \frac{P}{31.25} \approx \frac{\pi \cdot R^2}{31.25}, \quad (6)$$

where:  $P$  – rotor swept area [ $m^2$ ],  $R$  – rotor radius [ $m$ ].

The radius of the rotor,  $R$ , is approximately equal to the blade length,  $D$ . This is merely an approximation because the rotor swept area is calculated with respect to the middle of the rotor. However, this middle point is not exactly at the beginning of the blade, but rather in the middle part of the hub. As a result, the size of the hub determines the error of this approximation.

To calculate the mean width of a single triangular blade,  $S$ , it is first necessary to know its maximum width (at the hub – see Fig. 6):

$$S_{\max} = \frac{2A}{3R}. \quad (7)$$

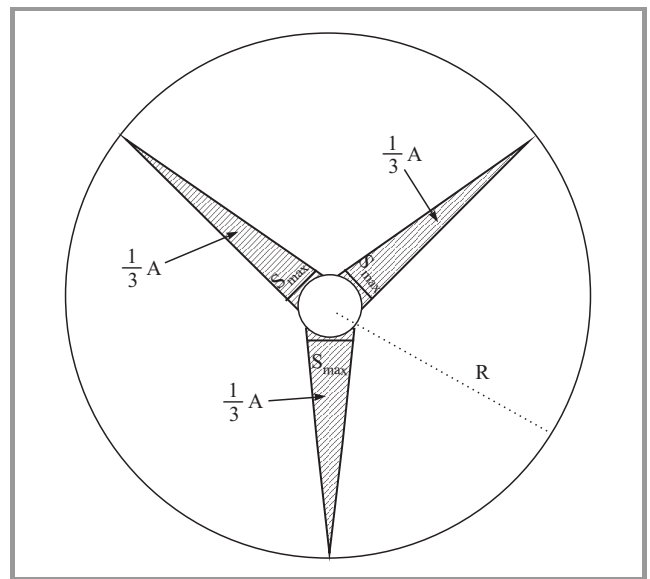

Fig. 6. Explanation of the  $S_{\max}$ ,  $A$  and  $R$  parameters.

Finally, the required value of the mean width of a single, triangular turbine's blade can be expressed as:

$$S = \frac{S_{\max}}{2}. \quad (8)$$

In the following part, the results of the measurements and simulations for the wind farm located in Kisielice in the Warmia-Masuria Province (northern Poland) will be pre-



sented. At this location, a total of three measurement scenarios were executed, but as it was mentioned at the beginning of this Section, the detailed results will be provided only for one of them. The parameters of the turbines belonging to the Kisielice wind farm – obtained through the available documentation (e.g. [9]–[11]) and calculated using Eqs. (6)–(8) have been gathered in Table 1.

Table 1  
Parameters of the turbines utilized at the analyzed wind farm

Number of turbines	27
Turbine’s tower height [m]	85
Length of the blades [m]	38.5
Blades width at the hub [m]	2.6
Mean width of a blade [m]	1.3
Area of a single blade [m <sup>2</sup> ]	49.7
Number of the blades	3
Total area of the blades [m <sup>2</sup> ]	149
Material (blades)	Fiber glass (reinforced with epoxide resin)
Turbines’ layout (arrangement)	Non-uniform
Distance between the turbines [m]	274–509

In this particular scenario, the distance between the wind farm and the transmitter was approx. 1.7 km and the distance between the wind farm and the receiver – approx. 2.22 km. The distance between the transmitter (receiver) and the wind farm is defined in this case as the line starting at the transmitter’s (receiver’s) location and perpendicular (normal) to the line of turbines. Before the campaign, a thorough mathematical analysis was conducted which considered the measurement equipment limitations as well as some dependencies which are true for the typical wind farms configurations. The analysis of these factors resulted in a set of assumptions, conditions and initial requirements for the campaign, such as the acceptable distances between the measurement equipment elements and the wind turbines. Obviously, each and every scenario that was actually carried out during the campaign (including the one described above) satisfied those initial conditions. During the measurements, both the transmit and receive directions were approximately normal to the rotors’ planes, which was a highly desirable situation from the measurement’s purposes point of view (it ensured a maximum reflection from the blades). Before the scenario described above was selected, it had also been verified that it exhibited a favorable terrain profile, i.e., the receiver was elevated and the rotors were directly visible from both the transmitter’s and receiver’s locations.

The measurement results of the direct FSR and reflected UFSR signals are depicted in Fig. 7a (screenshot from the Anritsu MS2721B spectrum analyzer). In Fig. 7b, the theoretical results – obtained through the simulations in the software tool – are presented. The software tool was developed at the NIT and it is based on the ITU-R BT.1893

model. In both cases, the analysis was carried out for the 161 MHz frequency. In the simulations, the assumed value of the scattering coefficient  $\rho$  was 6 dB less than the value resulting from Eq. (1). It is caused by the fact that rotors’ blades at the analyzed wind farm are not metallic but rather made of fiber glass, so their capability of reflecting the signal is substantially reduced (see Section 2).

During the simulations, the propagation attenuations for the transmitter – receiver and the transmitter – turbine paths were calculated using the free-space loss model, whereas the Okumura-Hata model for open area was utilized in case of the turbine – receiver path<sup>5</sup>. The measurement scenarios were selected in such a way, that conditions on the transmitter – receiver and the transmitter – turbine paths were as close to free space as possible, e.g., the transmitter placed on a hill, lack of obstacles between the transmitter and receiver, line of sight between the receiver, transmitter and the turbines and so on.

As it can be seen in Fig. 7, the maximum measured level of the reflected signal (UFSR) is –86.1 dBm, whereas its theoretical value, calculated using the model under the assumption of the maximum signal reflection from a single rotor, is –70.6 dBm. It means the measured value is roughly 15 dB less than the simulated one. Quite a significant discrepancy, which could be observed here may be caused by a combination of the following factors:

- the model does not include actual obstacles in the signal propagation path,
- the planes of rotors during the measurements might not have been precisely normal (perpendicular) to the transmit and receive directions, so the observed reflection might not have been maximized,
- the material the rotors are made of actually reflects the signal weaker than some sources indicate (see Section 2 of this article),
- the parameters of the turbines employed in the calculations are not fully accurate,
- the ITU-R BT.1893 model is clearly pessimistic in case of the VHF band.

In Table 2, the results obtained for all measurement scenarios (including the one discussed above) have been presented. All those measurements were conducted for 161 MHz and included each of the four analyzed wind farms. In the table, the measurement data was compared with the theoretical values resulting from the ITU-R BT.1893 model.

As it can be observed in Table 2, the measured values of the received signal level (UFSR) at 161 MHz were less by 13.4 dB (on average) than the theoretical ones, calculated using the ITU-R BT.1893 model. Additionally, it can also be seen, that for the case of the maximum reflection,

<sup>5</sup> Okumura-Hata model assumes the transmitter (base station) height in the range of 30–200 m and the receiver height in the range of 1–10 m. These assumptions were only satisfied for the turbine – receiver path.

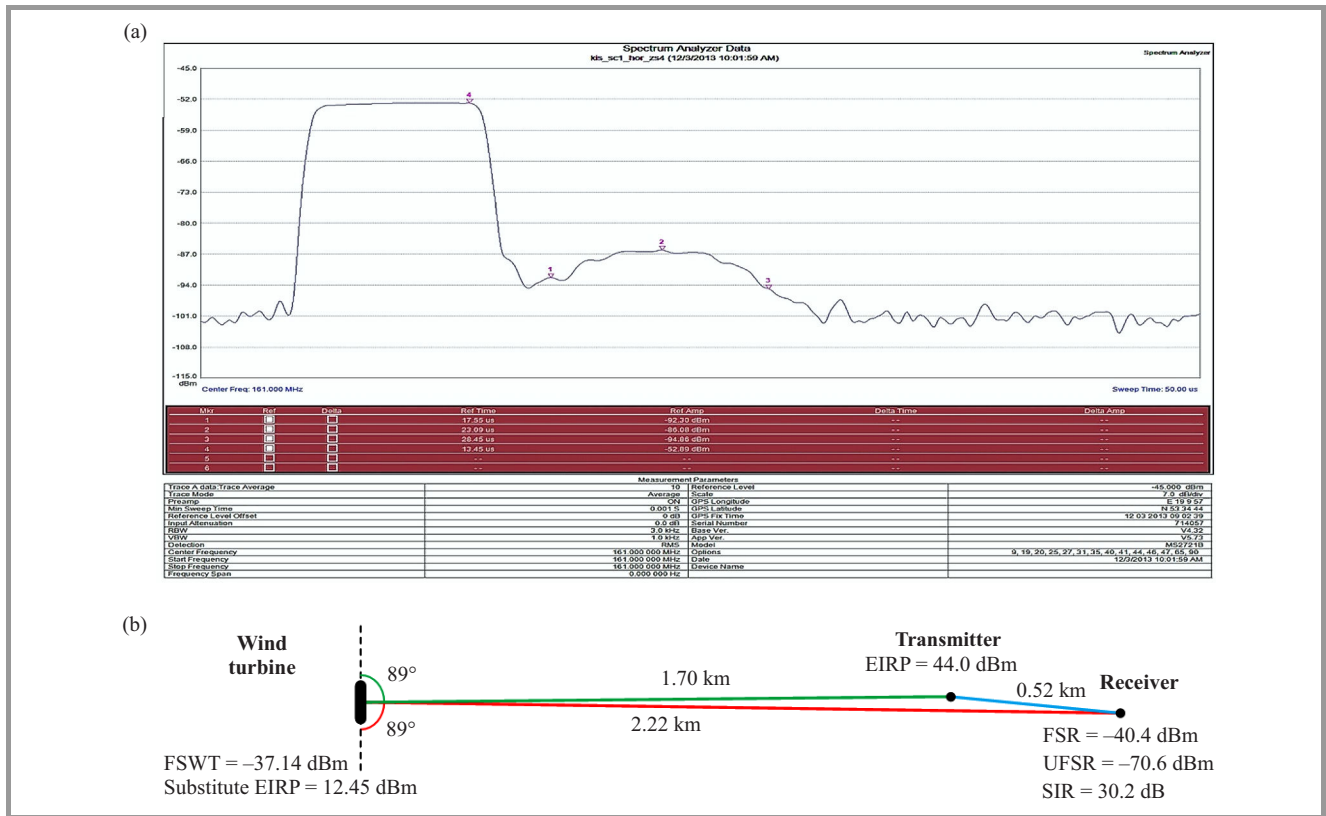

Fig. 7. Results obtained in the time domain in 161 MHz bandwidth for horizontal polarization: (a) measurements, (b) simulations.

Table 2  
Measured versus theoretical results obtained for the wind farms under consideration, at the frequency of 161 MHz

Farm (F)/Scenario (S)	Maximum measured UFSR level [dBm]	Theoretical UFSR value from the simulations [dBm]	Difference [dB]
F1/S1	-80.7	-68.7	-12
F2/S1	-82.5	-76.9	-5.6
F3/S1	-86.1	-70.6	-15.5
F3/S2	-82.2	-73.9	-8.3
F3/S3	-79.5	-67.3	-12.2
F4/S1	-86.3	-67.3	-19
F4/S2*)	-90.6	-126.2	35.6
F4/S3	-88.2	-67.1	-21.1
<b>Mean difference (error):</b>			<b>-13.4</b>

\*) The reference scenario – does not count towards the mean error value. In this case it was assumed that the angle between the and the transmit/receive direction was equal to 180° – i.e. unlike the other scenarios, it was not the case rotors' planes of the strongest reflection.

- F1 – Gnieźdźewo wind farm (Pomerania Province)
- F2 – Lisewo wind farm (Pomerania Province)
- F2 – Kisielice wind farm (Warmia-Masuria Province)
- F4 – Margonin wind farm (Wielkopolska Province)

the theoretical values of UFSR were always greater than those obtained in the measurements. Consequently, the analyzed model can definitely be described as pessimistic, and very suitable for the worst-case scenario analysis, because in real conditions the reflected signal levels will most likely be lower than the values resulting from the model.

At this point, it should be recalled that propagation models, such as the one discussed in this paper, generally allow to calculate the attenuation median, i.e., the received signal levels that are not exceeded in 50% of cases. Additionally, for wireless mobile system it is required to keep the so-called large-scale fading margin which is about -13 dB

(if we want to calculate the signal level exceeded in 99% of the cases) and +13 dB (if we want to calculate the signal level not exceeded in 99% of the cases)<sup>6</sup>. As we can see, this value is close to the average error indicated in Table 2. Consequently, it can be assumed that the ITU-R BT.1893 model simply takes into account the margin for the fluctuations of the propagation attenuation. Given the observations above, it might be stated that despite some discrepancies between the simulated and measured values, the ITU-R BT.1893 model is sufficient for the analysis of the wind farms’ influence on radio systems operating in the VHF band – especially for the worst case analysis.

## 5. The Simulation Analysis

Since it was verified that the ITU-R BT.1893 can be applied for both VHF and UHF bands<sup>7</sup>, the NIT created a software implementation of this model in order to perform a simulation analysis of the wind farms’ impact on these two frequency bands. In the first part of this Section, the authors will briefly discuss the software capabilities and then the simulations assumptions and results will be presented.

### 5.1. Short Information about the Software Tool

The simulation tool, created by the NIT for the purpose of this research, can generally operate in two modes. The first of the application’s modes enables the analysis of the wind farm influence on the radio signal propagation for a single set of input parameters, including the parameters of the turbine, transmitter and receiver, such as:

- the distance between the turbine and the transmitter and the distance between the turbine and the receiver,
- the transmitter’s parameters including: radio signal frequency, EIRP power, antenna pattern, angle of the incident signal at the turbine blades, etc.,
- the receiver’s parameters including: the height of the receiver, receive antenna gain, wanted field strength at the receiving location (FSR), angle of the signal reflected (scattered) from the turbine blades, etc.,
- the wind turbine’s parameters: the length and area of the turbine blade and its mean width, turbine’s height, number of turbines, signal strength at the wind turbine location (FSWT), the material the turbine blades are made of, etc.

As it was mentioned previously, the application uses the free-space loss model to calculate the propagation attenuation for the transmitter – turbine path (due to significant heights of the wind turbines), whereas the attenuation for

<sup>6</sup> Values derived on the basis of the ITU-R P.1546-5 recommendation for mobile wireless communications [12].

<sup>7</sup> Besides the 161 MHz band, the measurements conducted by the NIT covered the bands of 50 MHz and 400 MHz as well.

the turbine – receiver path is estimated using the Okumura-Hata model for open area [13].

As a result of the simulations, the application produces several output values, most notably the UFSR (the unwanted received signal level, i.e., the level of the signal component which reflected from the turbine blades) and the equivalent EIRP power, i.e., the hypothetical EIRP value that would have to occur at the turbine, so that the received signal level was equal to the UFSR.

The second mode of the application enables a graphical presentation of the UFSR for a given area, under the assumption the transmitter’s and turbine’s positions are fixed. In this mode, for every potential location of the receiver (i.e., for every point of the analyzed area), the software tool calculates the respective UFSR value, which is then presented graphically, using the appropriate color mapping. The application also allows to calculate the characteristics of the UFSR and the equivalent EIRP as a function of selected parameters, such as the radio signal frequency, the angle of the reflected signal, etc.

Additionally, for the purpose of the simulations discussed in this Section, the authors have also utilized a professional software tool for radio planning. The tool was created by the NIT and in this case it was used to model a turbine as an equivalent radio transmitter.

### 5.2. Simulation’s Assumptions and Methodology

The simulations were conducted for two frequencies representing each of the analyzed bands: 160 MHz (VHF) and 400 MHz (UHF).

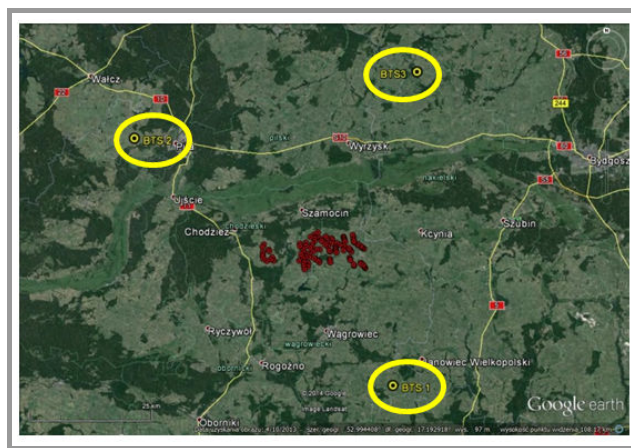

Fig. 8. The location of the base stations around the Margonin wind farm.

For the purpose of the simulation analysis, the location of three fictitious base stations (transmitters) in the vicinity of the Margonin wind farm<sup>8</sup> has been assumed. This arrangement is presented in Fig. 8 (base stations are marked in circles as BTS1, BTS2 and BTS3, respectively), and addi-

<sup>8</sup>The Margonin wind farm is located in the Wielkopolska Province (west-central Poland).



tionally in Tables 3 and 4, the parameters used during the simulations have been gathered.

Table 3  
The parameters used during simulations

Transmit antenna height [m above terrain level]	50	
Receive antenna height [m above terrain level]	2	
Transmit signal frequency [MHz]	160	400
EIRP power of the transmit signal [dBm]	46	54
Receiver sensitivity [dBm]	-105	
SNR required level [dB]	10	
Propagation model	Okumura-Hata	
Environment type	Suburban	
Fading margin [dB]	0	

Table 4  
Parameters of the turbines utilized at the analyzed wind farm

Number of turbines	105
Turbine's tower height [m]	100
Length of the blades [m]	45
Blades width at the hub [m]	3
Mean width of a blade [m]	1.5
Area of a single blade [m <sup>2</sup> ]	67.9
Number of the blades	3
Total area of the blades [m <sup>2</sup> ]	203.6
Material (blades)	Carbon skeleton covered with reinforced fiber glass
Turbines' layout (arrangement)	Non-uniform
Distance between the turbines [m]	418–1416
Notes:	
<ul style="list-style-type: none"> <li>• Due the blades' length (45 m), a small area around the wind farm is in the near field region (the Fraunhofer distance for 160 MHz is 24 m, and for 400 MHz – 60 m).</li> <li>• Due to the non-metallic blades, the value of the scattering coefficient <math>\rho</math> used in the simulation was 6 dB less than the value resulting from Eq. (1).</li> </ul>	

In order to evaluate the level of negative interactions between the wind farms and the radiocommunication systems, two cases should be considered:

- the radio shadowing analysis – where a wind farm is considered to be a terrain obstacle in the radiowave propagation path,
- the interference analysis – where a farm is considered to be a source of interference in the form of the reflected (secondary) radiowaves. In this approach, a turbine should be analyzed as a hypothetical, equivalent “radio transmitter” which is operating with an equivalent EIRP power and is equipped with an equivalent antenna.

Due to the assumed arrangement of the base stations, the services ranges of all three stations overlap in the vicinity

of the wind farm, and consequently it was not necessary to carry out the radio shadowing analysis in this paper. This situation is illustrated in Fig. 9.

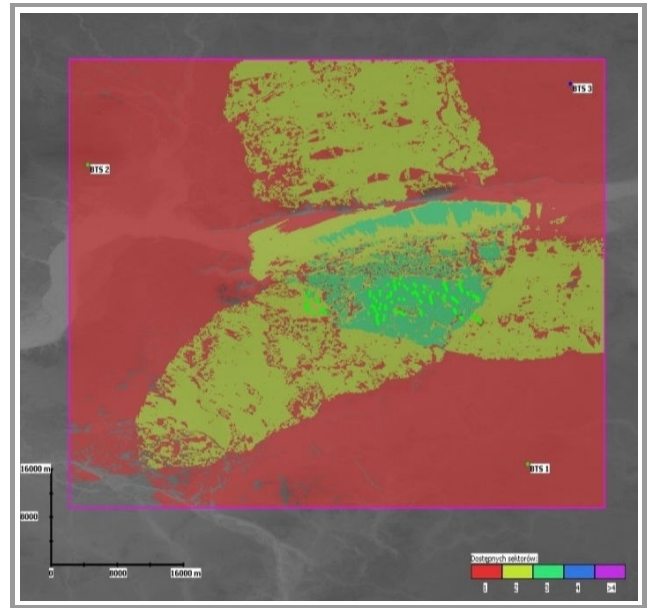

Fig. 9. The overlap of the base stations' service ranges around the analyzed wind farm (160 MHz frequency).

In case of the interference analysis, it was first necessary to calculate – on the basis of the turbines' parameters – the characteristic of the UFSR as a function of the angle between the receive direction and rotor's plane (see Fig. 10). The resulting far field characteristics for both the frequency of 160 MHz (Fig. 10a) and the frequency of 400 MHz (Fig. 10b) have been obtained for the worst case scenario where the rotor's plane is perpendicular to the transmit direction, which corresponds to the maximum signal reflection from the turbine's blades.

In Fig. 11, the distributions of the UFSR parameter for the 25 × 25 km area are shown. The illustrations were drawn for the assumed location of the transmitter with respect to the wind turbine and they represent the entire UFSR characteristic as a function of the receive angle. In these figures,  $\theta_{\text{receiver}} = 0^\circ$  is represented by the left edge of the area's bottom half, whereas  $\theta_{\text{receiver}} = 180^\circ$  angle is represented by the left edge of the area's upper half. The process of increasing the angle value between 0–180° can be illustrated as moving counterclockwise over the area. Consequently, the illustrations could be interpreted as the horizontal pattern of the equivalent directional antenna for the frequencies of 160 MHz (Fig. 11a) and 400 MHz (Fig. 11b).

On the basis of the information contained in Figs. 10 and 11, the parameters of the equivalent directional antenna for the frequencies of 160 MHz and 400 MHz have been defined and presented in Table 5.

In the next step, the equivalent EIRP power values were calculated using the parameters of the base stations and the wind turbines indicated previously. The calculations



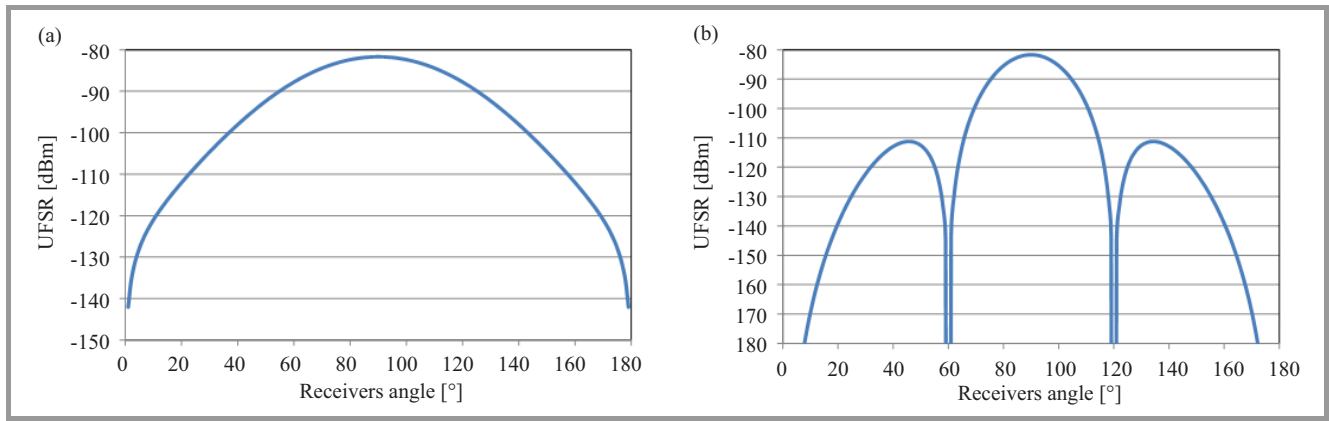

**Fig. 10.** The UFSR vs the angle between the receive direction and the wind turbine’s rotor plane for the frequency of: (a) 160 MHz, (b) 400 MHz.

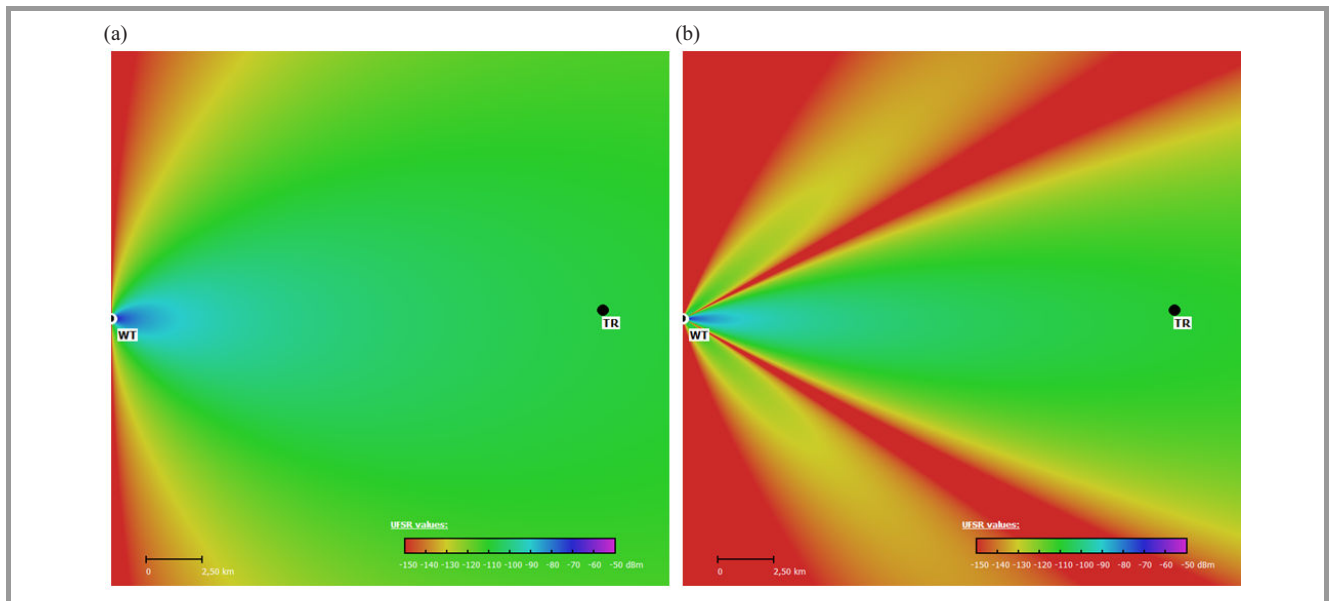

**Fig. 11.** The UFSR value distribution for the 25 × 25 km area: (a) transmission in the 160 MHz band, (b) transmission in the 400 MHz band (WT – location of the wind turbine, TR – location of the transmitter).

were conducted under the assumption of the worst-case scenario analysis, i.e., for the case of the maximum reflection from the rotors. Additionally, taking the characteristics of the equivalent antennas into account, a configuration of the so-called dispersed interference source has been obtained. This dispersed source is comprised of multiple hypothetical “radio transmitters” (i.e. wind turbines) which radiate the signal towards each of the analyzed base stations. These stations are obviously a source of the wanted signal, but indirectly they also generate sec-

ondary interferences, which are caused by the reflections of the radio signal from the turbines’ rotors. In Fig. 12, the notion of the equivalent sources of the secondary interfering signals has been explained. The arrows designate the azimuths of the main lobes of the equivalent directional antennas. During the simulations, it was assumed that the strongest interference only occurs for the rotors’ azimuths that align with the direction between the base station and the wind farm. The above assumption means that in real conditions the actual interference level in most cases will be lower than the values resulting from the simulations. Furthermore, there should never occur secondary interference levels higher than the simulated ones.

Table 5

The parameters of the equivalent directional antennas

Frequency [MHz]	160	400
Antenna gain [dBi]	0	0
3 dB horizontal beamwidth [°]	43	19
10 dB horizontal beamwidth [°]	79	33

In Table 6, the equivalent EIRP power values, calculated for the analyzed base stations, have been gathered. It should be added that the EIRP power values of the base stations’ transmitters assumed in these simulations have been ad-

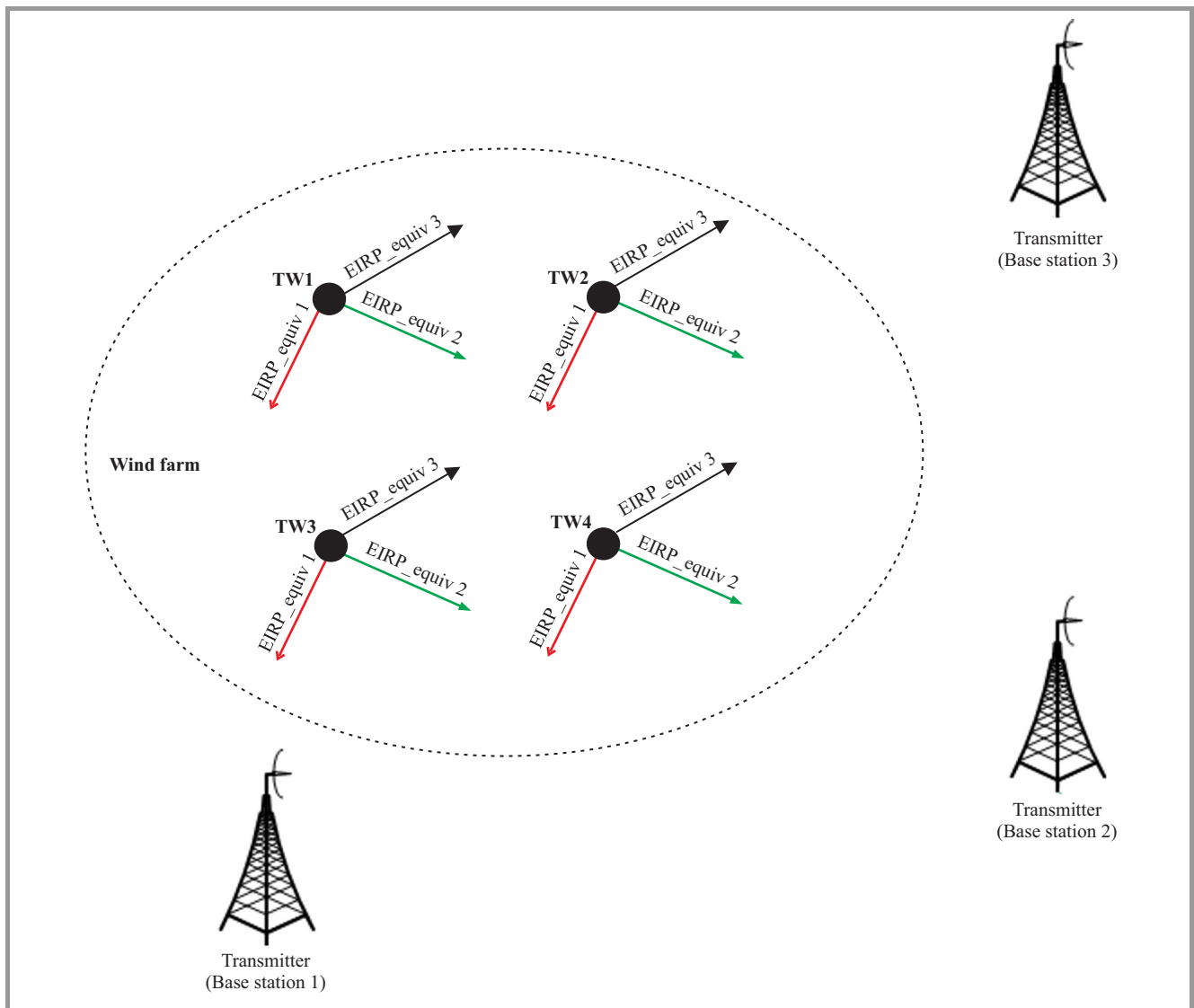

Fig. 12. The concept of the equivalent EIRP power and the arrangement of the secondary interference sources for specific directions.

justed in such a way that the signal strengths directly at the wind turbine location were equal for both analyzed frequencies. Such an approach was necessary to reliably compare the wind farm’s influence on the systems operating at 160 and 400 MHz.

Table 6  
The equivalent EIRP power values calculated for the analyzed base stations

	BTS 1	BTS 2	BTS 3
Distance to the middle of the wind farm [km]	32	44	41
Azimuth relative to the middle of the wind farm [°]	152	301	29
Equivalent EIRP power for 160 MHz [dBm]	-13	-15.8	-15.4
Equivalent EIRP power for 400 MHz [dBm]	3.2	0.4	0.9

### 5.3. Simulation Results

The simulation results for both analyzed frequencies are presented in Figs. 13–15. In Fig. 13 the levels of the received signal including the interference from the wind farm are shown. The signal to interference ratio (SIR) is illustrated in Fig. 14, and finally the levels of the received signal very close to the farm are depicted in Fig. 15.

The parameters of the simulations are the same as those presented in Table 3.

In the received power level simulations (Figs. 13 and 15), red color (pointed by R arrow) indicates the area where the interference criterion is not satisfied, i.e., the actual signal to interference ratio (SIR) is less than the required minimum value (which is 10 dB in this case). In the worst case, in those areas there could be no coverage due to severe interferences and consequently, no radiocommunication could be maintained. The discussed places are marked in the SIR visualizations as well (Fig. 14).

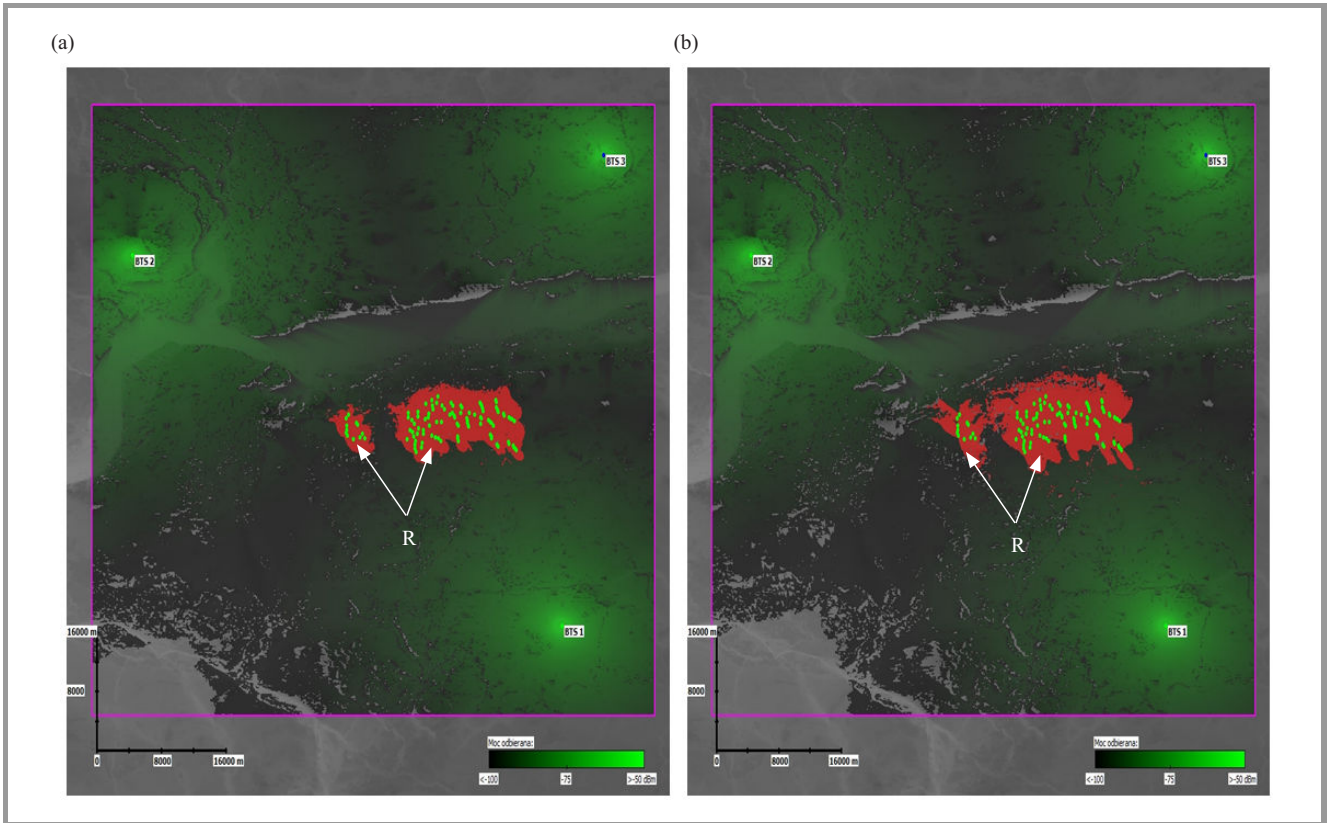

Fig. 13. Received power level simulation for the frequency of: (a) 160 MHz, (b) 400 MHz.

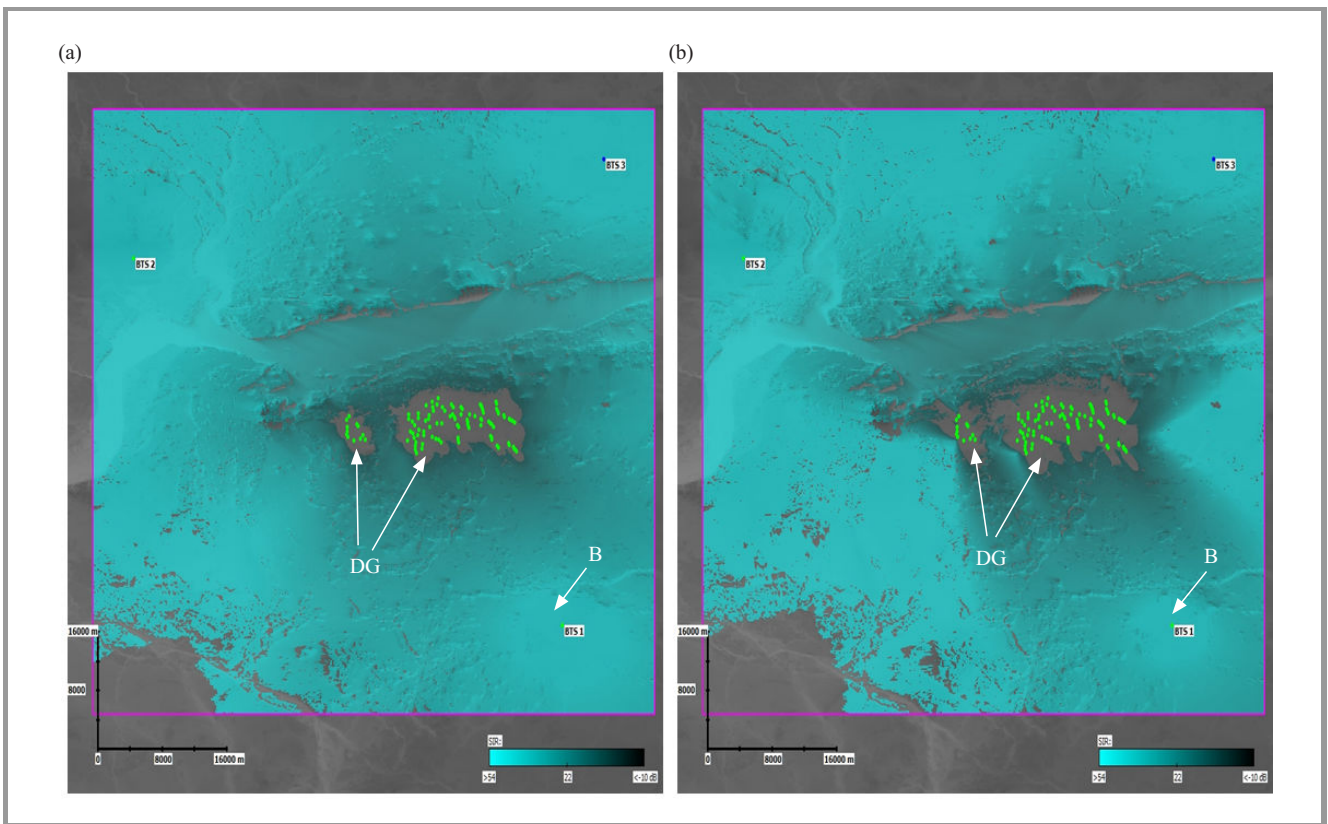
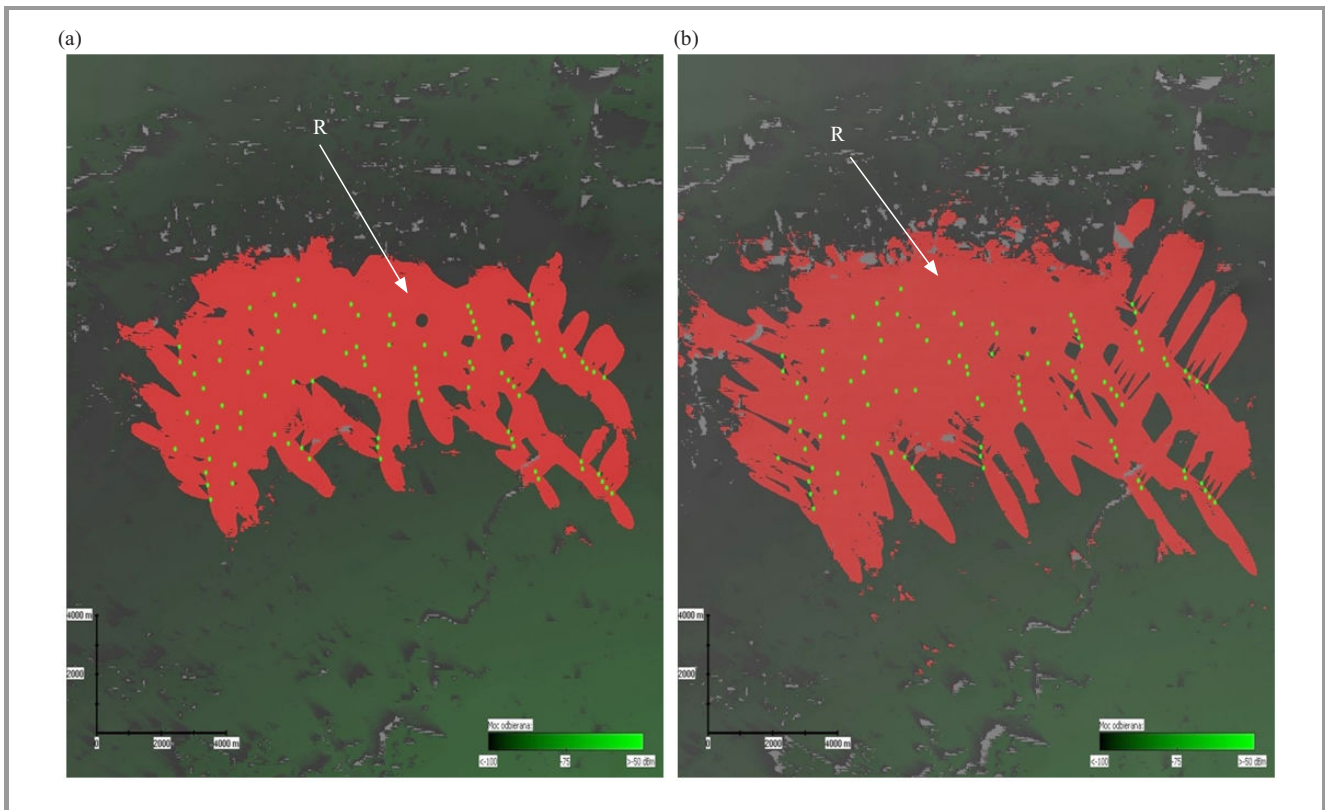

Fig. 14. Signal to interference ratio (SIR) simulation for the frequency of: (a) 160 MHz, (b) 400 MHz.





**Fig. 15.** Received power level simulation in the vicinity of the farm for the frequency of: (a) 160 MHz, (b) 400 MHz.

On the basis of the simulation results presented above, it can be observed that the area subjected to interference (where the signal to interference ratio is low) is significantly larger for the frequency of 400 MHz. It is caused by the fact that the scattering coefficient is proportional to frequency – see Eq. (1), so its value is greater at 400 MHz than at 160 MHz. It can be claimed that higher frequency translates into stronger reflection from the turbine’s components (most notably from its rotor). On the other hand, it is commonly known that the greater the frequency, the stronger the propagation attenuation. As a result, at 400 MHz the interferences are attenuated more significantly than at the lower analyzed frequency. Taking into account this fact only, one might expect completely different simulation results than those included in the figures above. However, if both phenomena are analyzed at the same time, it becomes clear that in the case of the wind farm under consideration and the assumed propagation conditions, the influence of the signal reflection at 400 MHz is too strong to be compensated by the propagation attenuation, which translates into higher interference level at this frequency.

The next observation regards the character of the interferences. In Fig. 10, the UFSR parameter has been drawn as a function of the reception angle for both analyzed frequencies. At 400 MHz, the resulting curve can be described as a “periodic” one, with a distinct set of “side lobes”, whereas the analogous characteristic for the

160 MHz is much more uniform and comprises only the “main lobe”. The above observation applies for the results presented in Figs. 13–15 as well. At 400 MHz, the area marked with grey color (which represents low values of SIR) is larger than at 160 MHz, but at the same time it is significantly shaped and its borders are much more distinct. The periodicity mentioned above is clearly visible in the figures: the areas of strong interference (dark grey color, DG arrow) are adjacent to the areas where the SIR is high (blue color, B arrow), while at 160 MHz the transitions between high and low SIR values are generally much more smoother.

It should also be underlined, the SIR value is affected not only by the frequency value or the turbines’ and transmitters’ parameters but also by the propagation phenomena which in turn depend on particular terrain features. By the definition, the SIR is a ratio of the wanted signal (the one that gets directly from the transmitter to the receiver) and the interference (i.e. the signal that gets from the transmitter to the receiver through reflection from the turbine). The terrain features can potentially affect these both components, thus determining the resulting SIR value.

## 6. Conclusions

This article dealt with a topic of wind turbines’ impact on a particular set of radio systems that operate in VHF



and UHF bands (around 160 and 400 MHz, respectively). Given the constant – and global – growth of interest in renewable energy sources, such as wind, the importance of that issue will probably become more and more significant in the near future.

In the article, the authors confirmed – through on-site measurements – that, under some assumptions, the ITU-R BT.1893 model can be applied to both UHF and VHF bands. After that – utilizing this model – they carried out a simulation analysis of the interactions between wind turbines and systems working in those bands. As it turned out, at the UHF frequencies, the areas subjected to interferences caused by the signal reflecting from the wind turbines are larger than in the VHF band. Additionally, in the UHF, the reflected signal is much more periodic than in the VHF, so the areas of very strong interference are adjacent to the areas where the interference is very low. Consequently, in the higher analyzed bands, it is more difficult to exactly predict which areas will be adversely affected by the wind turbines.

On the other hand, it has to be stated that the level of interaction between the wind farms and radio systems strongly depends on specific conditions: the turbines parameters, terrain profile, etc. As a result it would be hard (if not impossible) to formulate a universal and general rules set describing the influence of the wind farm on radio communications. What is really important is the methodology development and tools facilitating the analysis of this issue – and this article was a small attempt to do that.

## References

- [1] “Global Wind report – Annual Market Update 2013”, GWEC Global Energy Wind Council, 2013.
- [2] D. L. Sengupta, “Electromagnetic interference from wind turbines”, in *Proc. IEEE Antennas and Propagat. Soc. Int. Symp.*, Orlando, FL, USA, 1999, vol. 3, pp. 1984–1986.
- [3] “Impact of large buildings and structures including wind farms on terrestrial television reception”, BBC & Ofcom 2001 [Online]. Available: [www.oddzialywaniawiatrakow.pl/upload/file/190.pdf](http://www.oddzialywaniawiatrakow.pl/upload/file/190.pdf)
- [4] “The effect of scattering of digital television signals from a wind turbine”, Report ITU-R BT.2142-1 (10/2010), BT Series, ITU 2010.
- [5] “Assessment of impairment caused to digital television reception by a wind turbine”, ITU-R Rec. BT.1893 (05/2011).
- [6] “Assessment of impairment caused to analog television reception by a wind turbine”, ITU-R Rec. BT.805 (03/1992).
- [7] H. Dorner, “Efficiency and economic comparison of different WEC (Wind Energy Converters) rotor systems”, in *Int. Conf. Appropriate Technologies for Semiarid Areas*, Conf. Rep., Berlin, Germany, 1975 [Online]. Available: <http://www.heiner-doerner-windenergie.de/comparisonHAWTVAWT.pdf>
- [8] K. Adamczak, “Możliwości i efektywność bezpośredniej zamiany ruchu wirnika aerogeneratora na prąd” (“The possibilities and efficiency of the aerogenerator’s rotor movement transformation into current”), M.Sc. thesis, Poznan University of Technology, Poland (in Polish).
- [9] “Polish Society of Wind Energy” [Online]. Available: <http://www.psew.pl/pl>

- [10] “The Windpower” [Online]. Available: <http://www.thewindpower.net>
- [11] “Energetyka wiatrowa w Polsce”, Wikipedia [Online]. Available: [http://pl.wikipedia.org/wiki/Elektrownie\\_wiatrowe\\_w\\_Polsce](http://pl.wikipedia.org/wiki/Elektrownie_wiatrowe_w_Polsce) (in Polish).
- [12] “Method for point-to-area predictions for terrestrial services in the frequency range 30 MHz to 3000 MHz”, ITU-R Rec. P.1546-5 (09/2013).
- [13] “Prediction methods for the terrestrial land mobile service in the VHF and UHF bands”, ITU-R Rec. P.529-3 (10/1999).



**Krzysztof Bronk** received his Ph.D. in 2010. Now he is an Assistant Professor in National Institute of Telecommunications. He is an author or co-author of more than 30 reviewed scientific articles and publications and about 20 R&D technical documents and studies. His research is mainly centered on the field of radiocommunication

systems and networks designing and planning, software defined and cognitive radio systems development, multi-antenna technology, cryptography, propagation analysis, transmission and coding techniques as well as positioning systems and techniques. His interests includes also multi-thread and object oriented applications, devices controlling applications, DSP algorithms and quality measurement solutions. He is currently involved in research projects with both academic and industrial partners.

E-mail: [K.Bronk@itl.waw.pl](mailto:K.Bronk@itl.waw.pl)  
 National Institute of Telecommunications  
 Wireless Systems and Networks Department  
 Jaškowa Dolina st 15  
 80-252 Gdańsk, Poland



**Adam Lipka** received his M.Sc. and Ph.D. degrees in Telecommunication from the Gdańsk University of Technology in October 2005 and June 2013, respectively. Since January 2006, he has been working in the National Institute of Telecommunications in its Wireless Systems and Networks Department in Gdańsk

(currently as an Assistant Professor). His scientific interests include contemporary transmission techniques, MIMO systems and radio waves propagation. He is an author or co-author of over 40 scientific papers and publications.

E-mail: [A.Lipka@itl.waw.pl](mailto:A.Lipka@itl.waw.pl)  
 National Institute of Telecommunications  
 Wireless Systems and Networks Department  
 Jaškowa Dolina st 15  
 80-252 Gdańsk, Poland



**Rafał Niski** in 2001 graduated from Gdańsk University of Technology and received M.Sc. in the field of radio communication. Since that time he works in the National Institute of Telecommunications in Gdańsk, firstly as a Research Assistant, and after receiving the Ph.D. degree in 2006 as an Assistant Professor. From 2005

till 2012 he was the Wireless Systems and Networks Department Manager. His scientific research concerns the theory and techniques of mobile communication.

E-mail: R.Niski@itl.waw.pl

National Institute of Telecommunications  
Wireless Systems and Networks Department  
Jaškowa Dolina st 15  
80-252 Gdańsk, Poland

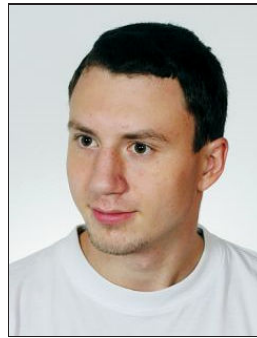

**Błażej Wereszko** received his M.Sc. in Electronics and Telecommunications from Gdańsk University of Technology in 2011. Since 2010 he works in the Wireless Systems and Networks Department of the National Institute of Telecommunications. His scientific interests focus on wireless communications, radio waves propagation

and radiolocation techniques.

E-mail: B.Wereszko@itl.waw.pl

National Institute of Telecommunications  
Wireless Systems and Networks Department  
Jaškowa Dolina st 15  
80-252 Gdańsk, Poland