



### Thermal Analysis Of A Gas Turbine Rotor Blade

<sup>1</sup>Gollapothu Boyaraju   <sup>2</sup> Sanmala Rajasekhar   <sup>3</sup> A.V Sridhar   <sup>4</sup>J.Hari Narayana Rao  
<sup>1</sup> M. Tech. Student, <sup>2</sup>Associate.Professor, <sup>3</sup>Associate.Professor  
Dept Of ME, KITS , DIVILI  
<sup>4</sup>Reserch Scholar

**Abstract :** A turbine rotor blade is the individual component which makes up the turbine section of a gas turbine. The blades are responsible for extracting energy from the high temperature, high pressure gas produced by the combustor. The turbine blades are often the limiting component of gas turbines. To survive in this difficult environment, turbine blades often use exotic materials like AL 2024 and T6 alloys. Turbine rotor blade is designed and analyzed in ANSYS 14.5

#### 1. INTRODUCTION

A turbine is a rotary mechanical device that extracts energy from a fluid flow and converts it into useful work. A turbine is a turbo machine with at least one moving part called a rotor assembly, which is a shaft or drum with blades attached. Moving fluid acts on the blades so that they move and impart rotational energy to the rotor. Early turbine examples are windmills and water wheels. Gas, steam, and water turbines have a casing around the blades that contains and controls the working fluid. A working fluid contains potential energy (pressure head) and kinetic energy (velocity head). The fluid may be compressible or incompressible. Several physical principles are employed by turbines to collect this energy:

Impulse turbines change the direction of flow of a high velocity fluid or gas jet. The resulting impulse spins the turbine and leaves the fluid flow with diminished kinetic energy. There is no pressure change of the fluid or gas in the turbine blades (the moving blades), as in the case of a steam or gas turbine, all the pressure drop takes place in the stationary blades (the nozzles). Before reaching the turbine, the fluid's *pressure head* is changed to *velocity head* by accelerating the fluid with a nozzle. Pelton wheels and de Laval turbines use this process exclusively. Impulse turbines do not require a pressure casing around the rotor since the fluid jet is created by the nozzle prior to reaching the blades

on the rotor. Newton's second law describes the transfer of energy for impulse turbines.

Reaction turbines develop torque by reacting to the gas or fluid's pressure or mass. The pressure of the gas or fluid changes as it passes through the turbine rotor blades. A pressure casing is needed to contain the working fluid as it acts on the turbine stage(s) or the turbine must be fully immersed in the fluid flow (such as with wind turbines). The casing contains and directs the working fluid and, for water turbines, maintains the suction imparted by the tube. Francis and most steam turbines use this concept. For compressible working fluids, multiple turbine stages are usually used to harness the expanding gas efficiently. Newton's third law describes the transfer of energy for reaction turbines.

#### 1.1 Introduction to CATIA

CATIA also known as Computer Aided Three-dimensional Interactive Application and it is software suit that developed by the French company call Dassult Systems. CATIA is a process-centric computer-aided design/computer-assisted manufacturing/computer-aided engineering (CAD/CAM/CAE) system that fully uses next generation object technologies and leading edge industry standards. CATIA is integrated with Dassult Systems Product Lifecycle Management (PLM) solutions. It allows the users to simulate their industrial design processes from initial concept to product design, analysis, assembly and also maintenance. In this software, it includes mechanical, and shape design, styling, product synthesis, equipment and systems engineering, NC manufacturing, analysis and simulation, and industrial plant design. It is very user friendly software because CATIA Knowledge ware allows broad communities of user to easily capture and share know-how, rules, and other intellectual property assets.

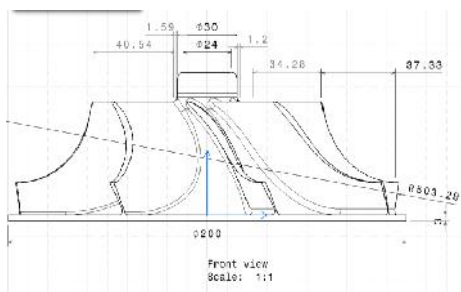
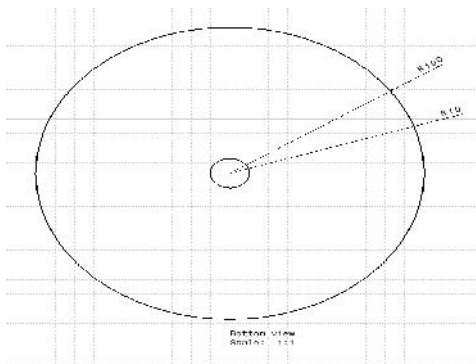
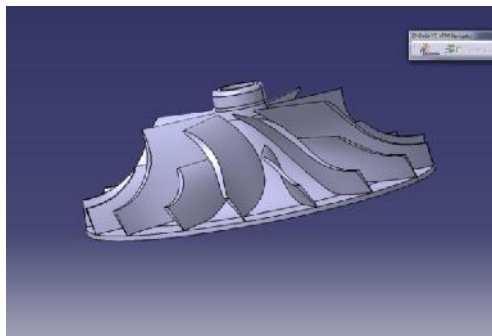
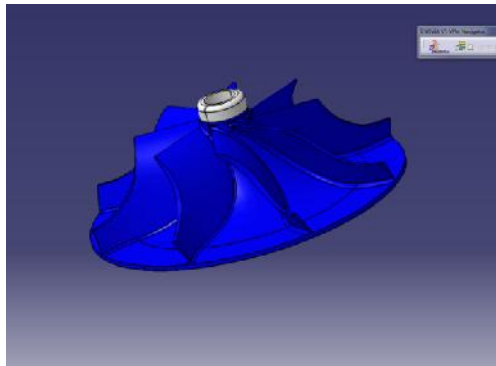

## 2. Introduction to Ansys

ANSYS is general-purpose finite element analysis (FEA) software package. Finite Element Analysis is a numerical method of deconstructing a complex system into very small pieces (of user-designated size) called elements. The software implements equations that govern the behaviour of these elements and solves them all; creating a comprehensive explanation of how the system acts as a whole. These results then can be presented in tabulated, or graphical forms. This type of analysis is typically used for the design and optimization of a system far too complex to analyse by hand. Systems that may fit into this category are too complex due to their geometry, scale, or governing equations.

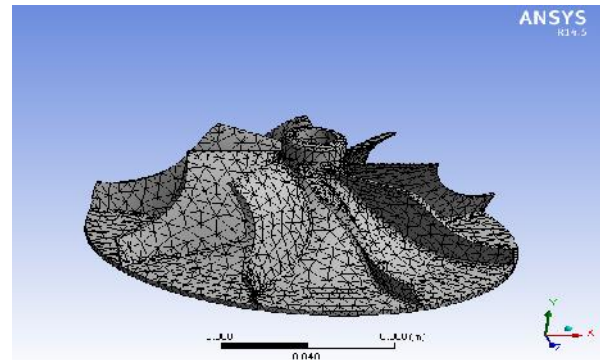

## 3. STRUCTURAL ANALYSIS GAS TURBINE ROTOR BLADE MODEL-1 WITH AL 2024 ALLOY

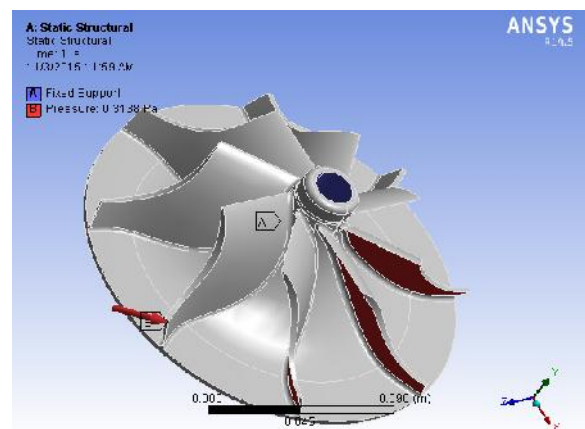

INPUT PARAMETERS

### 3.1 STRUCTURAL ANALYSIS GAS TURBINE

#### ROTOR BLADE MODEL-1 WITH T6 ALLOY

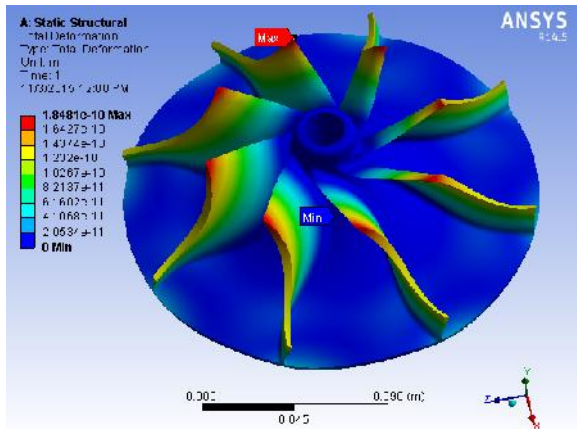

DISPLACEMENT

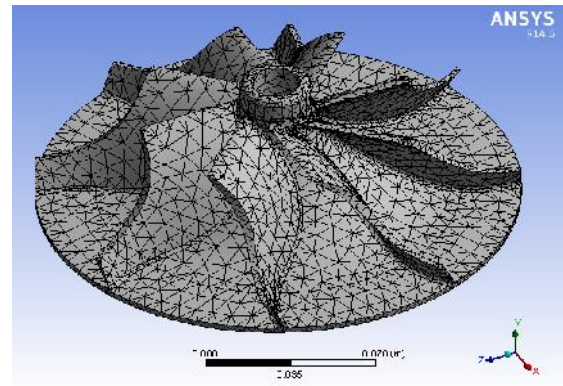

MESH MODEL

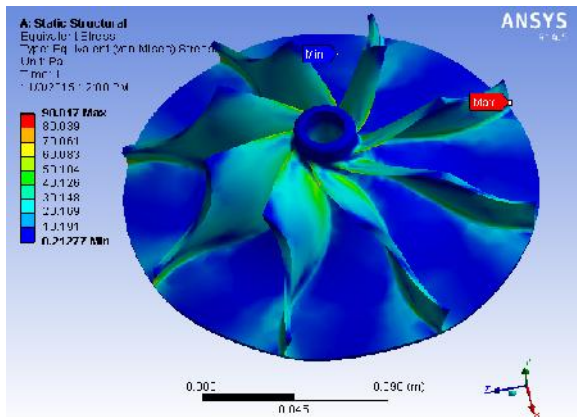

STRESS

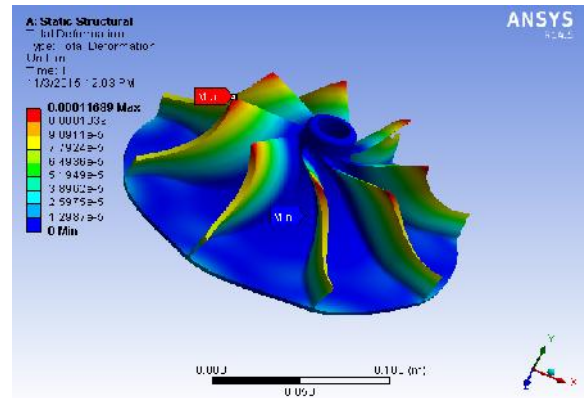

DISPLACEMENT

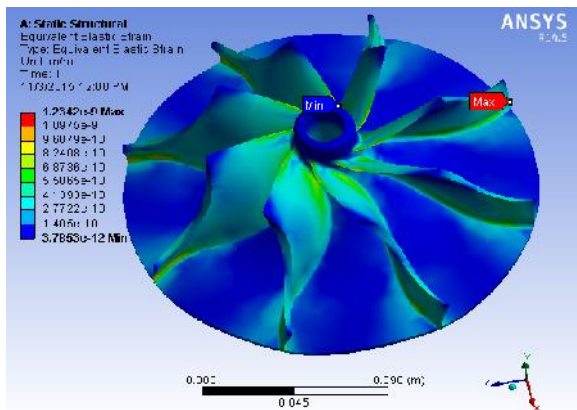

STRAIN

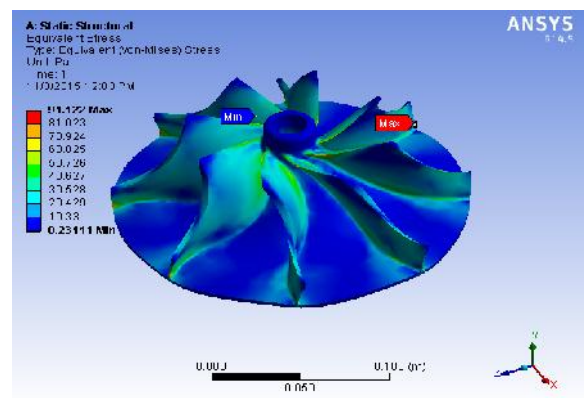

STRESS

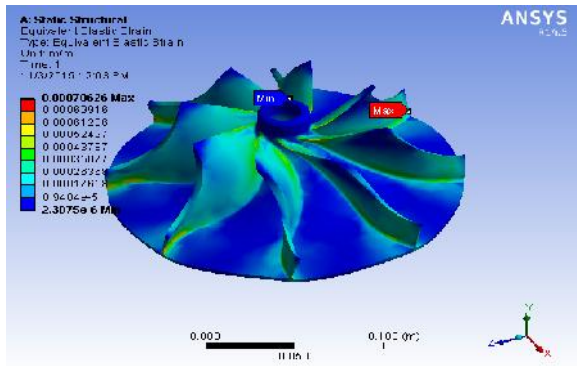

STRAIN

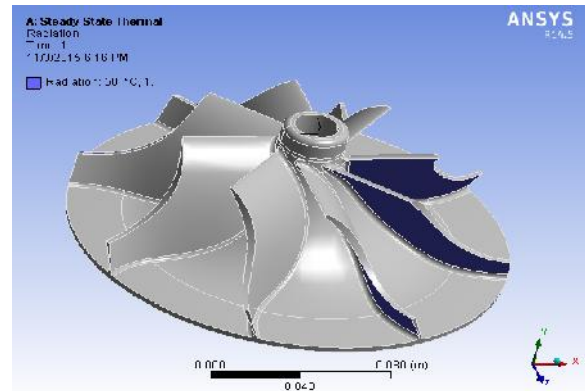

RADIATION

### 3.2 THERMAL ANALYSIS OF GAS TURBINE

#### ROTOR BLADE MODEL -1 WITH AL 2024 ALLOY

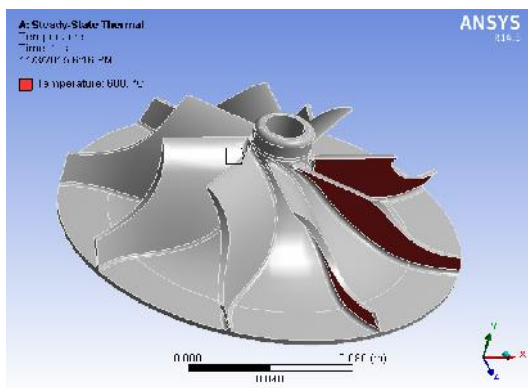

TEMPERATURE

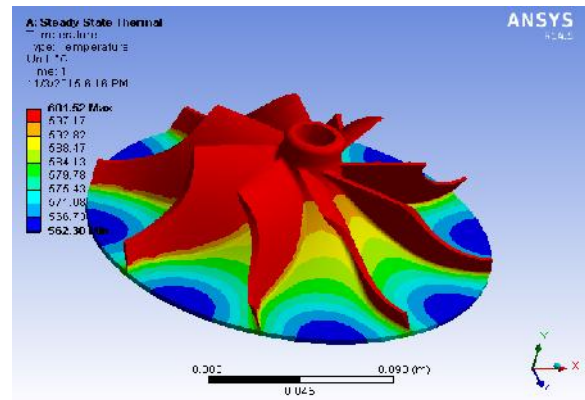

RESULTS TEMPERTURE

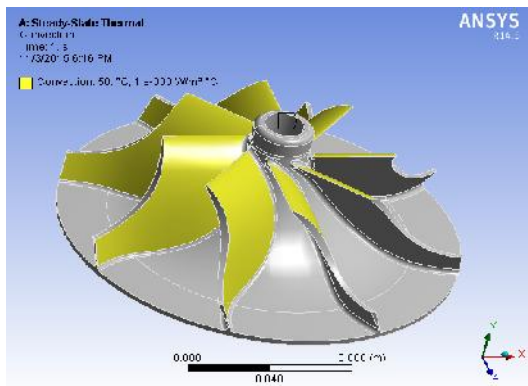

CONVECTION

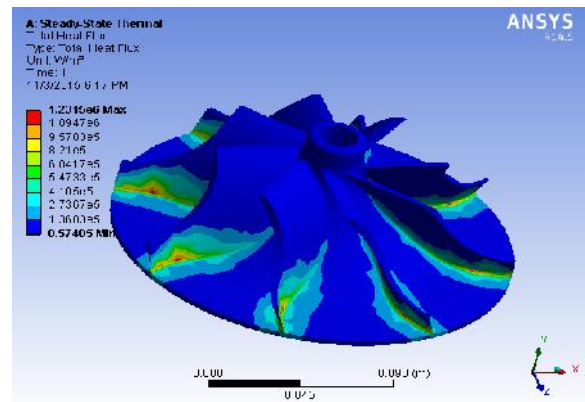

TOTAL HEAT FLUX

**4.STRUCTURAL ANALYSIS:**

	DISPLACEMENT	STRESS		STRAIN	
		MIN	MAX	MIN	MAX
BASIC MODEL AL2024	1.85E-10	0.21277	90.017	3.79E-12	1.23E-09
BASIC MODEL T6	0.00011689	0.2311	91.122	2.39E-06	0.000786

	DISPLACEMENT	STRESS		STRAIN	
		MIN	MAX	MIN	MAX
MODEL 2 AL2024	5.92E-10	0.27573	236.94	3.84E-12	4.15E-09
MODEL 2 T6	0.00037553	0.28171	236.51	2.46E-16	0.002355

MODEL 2

**THERMAL ANALYSIS:**

**BASIC MODEL:**

	TEMPERATURE		TOTAL HEAT FLUX		DIRECTIONAL HEAT FLUX	
	MIN	MAX	MIN	MAX	MIN	MAX
BASIC MODEL AL2024	562.38	601.52	0.57405	1.23E-06	-6.84E-05	6.78E-05
BASIC MODEL T6	399.55	608.64	0.28577	6.72E-05	-3.66E-05	3.62E-05

**MODEL 2:**

	TEMPERATURE		TOTAL HEAT FLUX		DIRECTIONAL HEAT FLUX	
	MIN	MAX	MIN	MAX	MIN	MAX
MODEL 2 AL2024	587.84	600.22	0.02829	4.44E-05	-4.03E-05	3.43E-05
MODEL 2 T6	509.14	601.77	0.072686	3.33E-05	-3.02E-05	2.56E-05

GRAPHS:

Structural Analysis:  
Basic Model:  
Displacement:

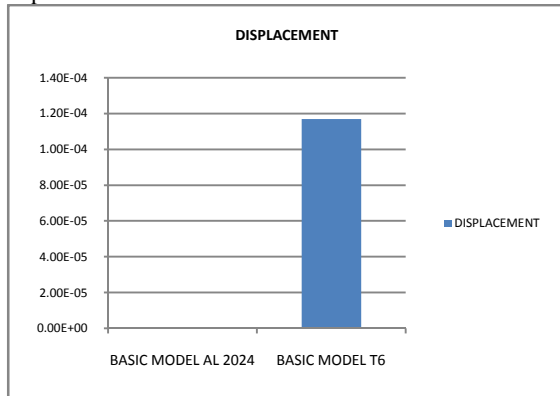

STRAIN:

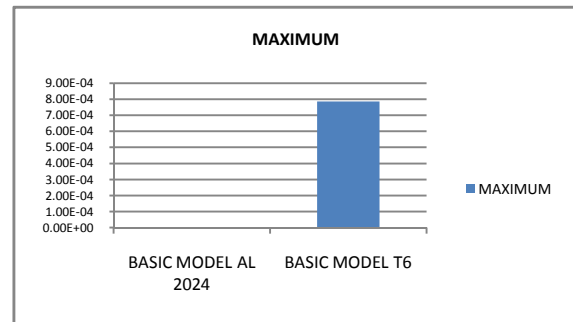

MAXIMUM

STRESS:

MINIMUM:

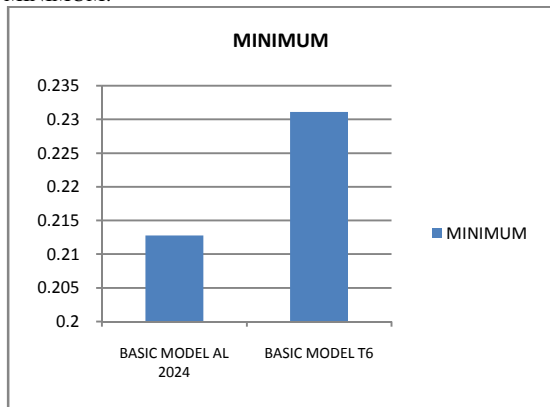

MINIMUM

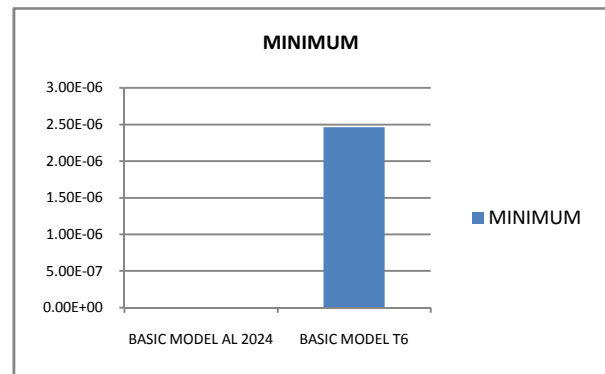

MODEL 2:

MAXIMUM:

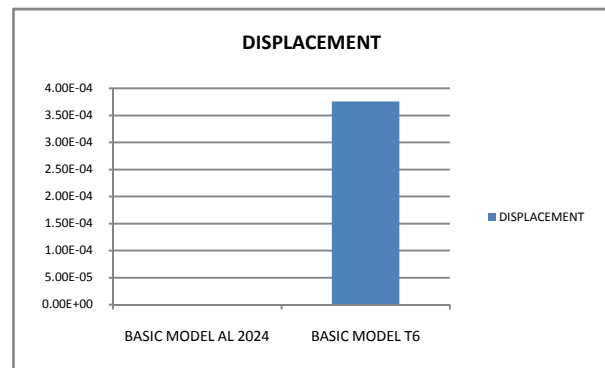
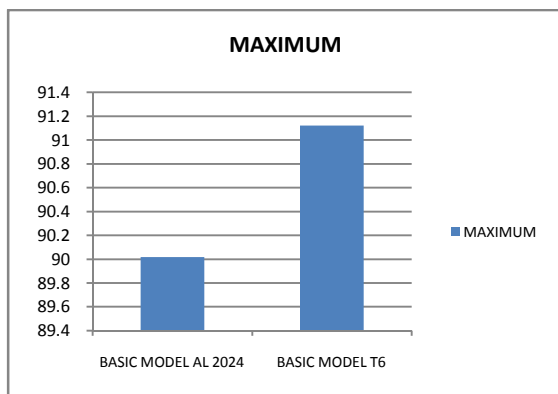

## CONCLUSION

In this paper a Gas turbine which is a mechanical device that extracts thermal energy from pressurized steam, and converts it into rotary motion. A system of angled and shaped blades arranged on a rotor through which steam is passed to generate rotational energy.

Here we have designed a gas turbine using Catia V5, and structural and thermal analysis is done to the different models and the results are verified in a graph and tables.

As we observe in the first model the structural analysis is done with 2 materials i.e. with AL 2024 & T6. As we observe in the results the material with AL 2024 is the best product which increases the life as we compare the results in the stress (90.017). So we can conclude that the material is the best output for model 1

As we observe in the second model the structural analysis is done with 2 materials i.e. with AL 2024 & T6. As we observe in the results the material with T6 is the best product which increases the life as we compare the results in the stress (236.51). So we can conclude that the material is the best output for model 2

As we observe in the first model the thermal analysis is done with 2 materials i.e. with AL 2024 & T6. As we observe in the results the material with AL 2024 is the best product which increases the life as we compare the results in the heat flux (1.23E-06). So we can conclude that the material is the best output for model 1

By comparing both the models lowest temperature is recorded in model one with T6 but lowest fluxes are recorded in model two with AL 2024. so we conclude model one with aluminum as best model and material for better life of the turbine, if we need more efficiency we should consider model two with t6

## REFERENCES

1. Introduction to Engineering Thermodynamics, Richard E. Sonntag, Claus Borrgnakke 2007. Retrieved 2013-03-13.
2. "Gas Turbines For Autos", May 1946, "Popular Science. Books.google.com. Retrieved 2012-08-13.

3. Kay, Antony, German Jet Engine and Gas Turbine Development 1930-1945, Airline Publishing, 2002
4. Operation of a Marine Gas Turbine Under Sea Conditions. Journal of the American Society for Naval Engineers, 66: 457-466. doi: 10.1111/j.1559-3584.1954.tb03976.x
5. Ingvar Jung, 1979, The history of the marine turbine, part 1, Royal Institute of Technology, Stockholm, dep of History of technology
6. Whitaker, Jerry C. (2006). AC power systems handbook. Boca Raton, FL: Taylor and Francis. p. 35. ISBN 978-0-8493-4034-5.
7. Speed Droop and Power Generation. Application Note 01302. 2. Woodward. Speed