



Grid Connected Single Phase Rooftop Pv System With Limited Reactive Power Supply

Tota Sankara Rao¹, Smt.N.Sirisha²

¹PG Scholar, Pydah College of Engineering, Kakinada, AP, India.

²Associate Professor, Pydah College of Engineering, Kakinada, AP, India.

Abstract- In this paper SRF theory based PV system with MPPT DC-DC controller for grid connected single phase rooftop system have been presented. Photovoltaic (PV) systems are the alternative source of generation because these can be placed near to the load centers when compared with other renewable source of generation. The rooftop PV system in general is grid connected and supports the off grid load with battery backup. It is therefore rooftop PV is the centre of attraction for majority PV systems. The proposed system must ensure total evacuation of generated power and with high efficiency of conversion, and utilizes the resource adequately to maximize the utilization of energy. The voltage source converter (VSC) will operate based on the PWM controller to realize maximum generated power evacuation by maintaining the DC link voltage as a constant value without any battery storage system, low THD sinusoidal line synchronized current output, and also limits the reactive power and controls the power factor based on the unutilized capacity of the inverter. This paper proposes SRF theory based PV system with MPPT DC-DC PWM controller. Incremental conductance (IC) method is used to get maximum power from the PV system. The simulation results shows the efficient working of rooftop PV with proposed control algorithms in grid connected mode using MATLAB/SIMULINK software.

Index Terms- MPPT, Synchronous reference frame (SRF), Incremental Conductance (IC), Photovoltaic (PV)

I. INTRODUCTION

The major utilization of these sources with grid integration is the challenging task. It is therefore Distribution Generation (DGs) particularly single phase rooftop PV system are major research area for grid integration, since these sources have huge opportunity of generation near load terminal. World is moving towards the greener sources of energy to make the planet pollution free and environment friendly. The rooftop application involving single phase DG's fed with PV source can be not only utilized for household use but the excess energy can be transferred to the grid through proper control scheme and adequate hardware. Control scheme based on instantaneous

PQ theory has been presented in some literatures for single phase system. Other control scheme such as synchronous reference frame (SRF) is mainly used with three phase system in which sinusoidal varying quantities are being transferred to dc quantities that provides better and precise control than PQ based control even under distorted condition of mains. But SRF based control scheme can be customized for single phase which can't be utilized to get the desired dc quantity to generate required reference command. PV sources are interfaced with the grid through voltage source converters (VSC's).

VSC's can be controlled either in PWM based voltage control method or hysteresis based current controlled method (HCC). HCC based controller gives fast response and better regulation but its major drawback lies with variable frequency. On the other hand the PWM based control gives fixed switching frequency that could be utilized easily for proper design of LC or LCL filters. With PV sources connected at the DC side of the inverter, it is utmost essential to fetch maximum power from the source to make the system efficient. Out of different algorithm to track maximum power point (MPP) such as perturb and observe (P&O), Incremental Conductance (IC) etc., IC based method provides fast dynamics and control over fast changing insolation condition. In this paper new control scheme based on SRF theory has been proposed for single phase rooftop PV grid connected system.

The VSC controller is designed in taking the advantage of both current and voltage controller which is called current driven PWM based voltage controller. Through the VSC the maximum tracked power is pumped into the grid through proper control on DC link voltage. By maintaining the DC link voltage constant during operation, is ensured the total power being generated by PV transferred across the DC bus by the inverter to the grid. Apart from active power transfer the system could be well utilized for providing limited reactive power compensation based on available capacity of the VSC. The detailed system configuration and various control schemes are briefly discussed and explained. The rooftop PV system with proposed scheme is simulated under the MATLAB simulink environment for grid connection to push real power into the grid along with limited power conditioning.

II. SYSTEM CONFIGURATION

Fig.1 depicts the schematic diagram of single phase grid connected PV system comprising PV panels, DC-DC converter, MPPT charge controller, tank capacitor, VSC and RL loads. IC based MPPT controller is used to extract the maximum available power from the PV panels. Control based on tank capacitor voltage is used to control the transfer of maximum power to the grid via VSC. The direct voltage controlled current driven VSC keeps the voltage across the tank capacitor constant by regulating the power evacuation through voltage control. Proper design of LCL filter at the output of VSC filters out harmonics at the PCC. The conventional 3 phase SRF theory is modified to suit the single phase system. The modified SRF theory is applied to decompose the load current to generate the reference reactive power current command. Reference for the real current component is obtained by applying PI controller on the error between measured voltage and the reference voltage.

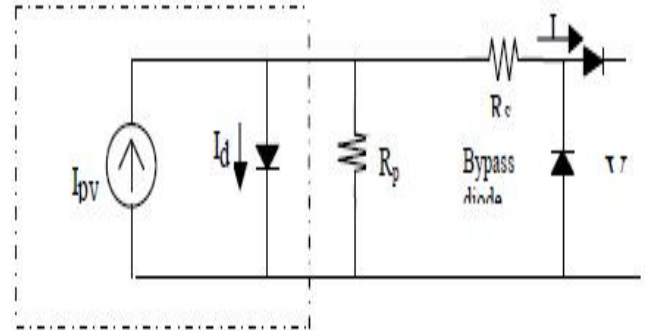

Fig 2 PV panel Model

IV. CONTROL THEORY

The proposed system the 3 phase SRF based theory is modified for single phase system. The heart of the control scheme lays with correct estimation of phase voltage though phase locked loop (PLL), which is used for generation of unit template vectors. The output of the PLL will be in phase with single phase voltage at PCC. For applying modified SRF theory to single phase system, phase voltage or current is assumed as alpha () component in - frame (stationary frame of reference), and component is obtained by introducing phase delay of 90° to alpha components as shown in Fig. 3. Using modified SRF theory both DG and load currents are transformed into d-q components and passed through low pass filter (LPF) to obtain only DC components corresponding to fundamental frequency as shown in Fig. 3. For such synchronized modified SRF theory based transformation and components corresponds to real and reactive power components respectively.

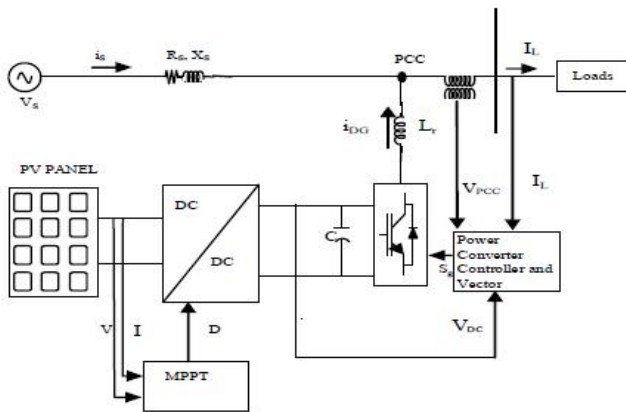

Fig. 1Block diagram for system configuration of PVDGCC

III. MODELING OF PV ARRAYS

The basic equations that govern I-V characteristic of the ideal photovoltaic cell are reported in literatures. The typical equation governing the PV arrays is given by (1)

$$I = I_{pv} - I_0 \left[\exp\left(\frac{V + R_p I}{V_{Tn}}\right) - 1 \right] - \frac{V + R_p I}{R_p}$$

Ns-Number of cells connected in series; Rp=Equivalent parallel Resistance; Rs= Equivalent contact series Resistance. Commercially available KC200GT Kyocera make PV panels are considered here to design the array to deliver power of 800W by connecting 3 panels in a string and similar 2 strings in parallel in MATLAB Simulink. The parameters of the panel are shown in Table I. The proposed charge controller operates to extract the maximum power at one level of solar insolation by using Incremental Conductance based MPPT controller.

**TABLE I
PARAMETERS OF THE KYOCERA MODEL
KC200GT SOLAR ARRAY AT NOMINAL
OPERATING CONDITIONS**

I _{pmax}	7.61A
V _{pmax}	26.3V
P _{max}	200.13
I _{sc}	8.21A
V _{oc}	32.9V
K _v	-0.1230 V/K
K _I	0.0032 A/k
N _s	54

Id and Iq obtained through transformation is passed through LPF to obtain the at DC quantities which after proper control on this DC quantity, it's again converted back to - component.

After transformation only component is used for signal generation. In the photovoltaic based grid connected system it is utmost important to extract MPP tracked power for economical operation and to avoid panels heating due to under utilization. To guarantee this, constant DC bus voltage

is required to be maintained across DC link capacitor, and reference current is generated to obtain the command voltage reference for PWM control of the VSC as shown in Fig. 3. The control forces the output current of VSC to closely follow the reference current.

The DG's main task is to send maximum power to the grid via VSC. In the event of varying insolation or during low insolation, the VSC capacity is not fully utilized for real power transfer. The unutilized capacity can be used for limited reactive power compensation. The depth of compensation is based on capacity remaining after deducting MPPT tracked PV power from the total capacity of VSC. In view of this reactive power component in load is determined and multiplied with 'k' showing the selective or amount of power to be compensated as shown in Fig. 3. This reference reactive command is compared with DG 'qDG' component and error is passed through PI controller to generate reference Vq* component. This voltage reference d-q component is then reverse transformed to - using equations (8). Out of the two components in stationary frame of reference v * component is used for PWM gating signal generation.

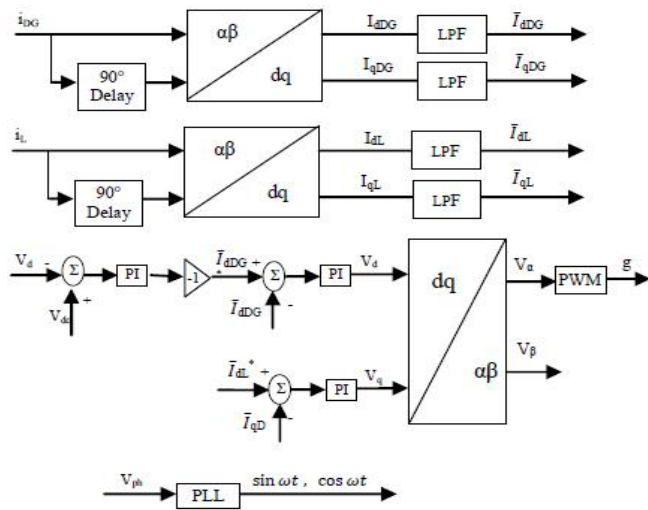

Fig. 3. Control Scheme for proposed System

LCL filter design:

Fig. 4 shows the LCL filter which is placed at the VSC output terminal to get the filtered output. Proper design of filter is crucial from the stability point of view. Applying KCL to the LCL circuit following equations are synthesized:

$$\begin{aligned}
 i_{vsc} - i_c - i_s &= 0 & (6) \\
 v_{vsc} - v_c &= i_{vsc} (R_1 + sL_1) & (7) \\
 v_c - v_s &= i_s [(R_2 + R_s) + s (L_2 + L_s)] & (8) \\
 v_c &= i_c (1/sC + R) & (9) \\
 \frac{i_s}{v_{vsc}} &= \frac{NG}{DG} & (10)
 \end{aligned}$$

Where,
 $N(s) = sRC + 1$

Table II
Parameters for LCL Filter

L ₁	3 mH
L ₂	3 mH
L _s	0.3 mH
R ₁	0.02 Ω
R ₂	0.02 Ω
R _s	0.02 Ω
C	40 μF
R	3 Ω

Table III
Parameters for Considered system

V _{ph}	230 V
R _L	5 Ω
L _L	4 mH
DC link Voltage	400V
Supply Frequency	50 Hz
Max. PV power	8.5 kW

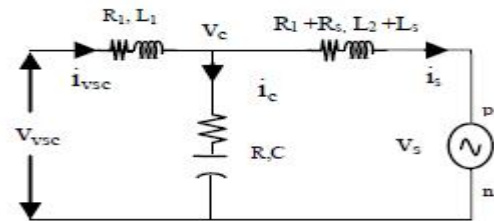

Fig. 4 LCL model

$$D(s) = [(L_2 + L_s) L_1 C] s^3 + [(L_2 + L_s) (R + R_1) C + (R_2 + R_s) L_1 C + L_1 C] s^2 + [(R_2 + R_s) (R_1 + R_s) C + R_1 C + L_2 + L_s] s + [(R_2 + R_s)] \tag{11}$$

Using above equations (6) - (10) circuit can be modeled as block diagram as shown in Fig. 5. For checking the stability of the filter design bode plot is drawn in the MATLAB for the parameters given in table II as shown in Fig. 6. From Fig. 6 it can be seen that the plot have overshoot near resonant frequency other plot with low damping and other with proposed system of LCL filter parameters show no overshoot and proper damping. The adequate passive damping provided avoids peak at resonant point and prevents loss of gain, by appropriately choosing the damping ratio. By keeping L1 and L2 same, reactive interaction of filter capacitance gets minimized with the line with minimized value of capacitance.

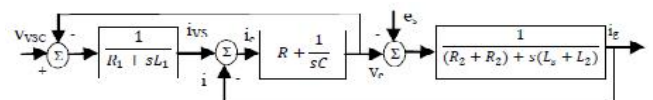

Fig. 5 Block diagram representation of LCL filter

V. SIMULATION RESULTS

The complete single phase grid connected PV system is simulated under MATLAB simulink with RL load (R= 4 Ω, L = 4 mH) as shown in Fig.7. PV panels are connected in series and parallel in such a way that array could deliver maximum power of 8.5 kW at 1000 W/m²

insolation level. IC based MPPT algorithm is verified by writing embedded MATLAB code. LCL filter is connected at the output of VSC as per parameters given in the table II. The simulated results are studied to compute the performance of single phase grid connected system under limited available capacity of VSC. The parameters of the considered system are shown in Table-III.

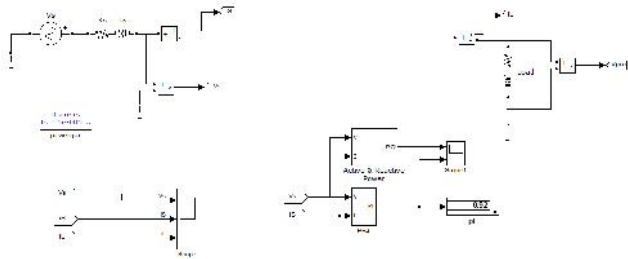

Fig 6 simulation diagram of single phase system

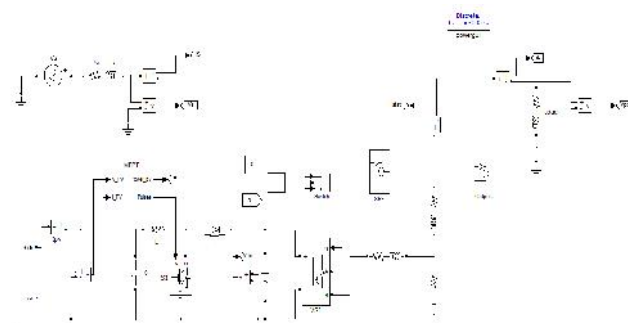

Fig 7 simulation diagram of proposed system with PV

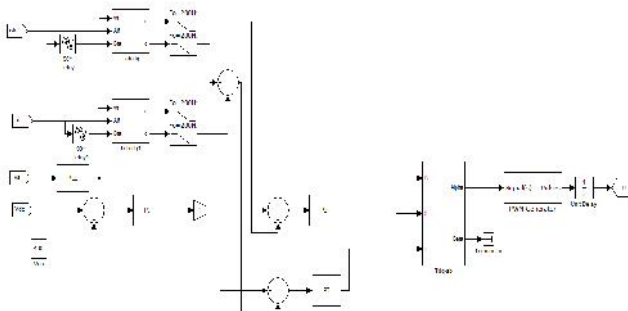

Fig 8 simulation diagram of SRF controller for the proposed system with PV

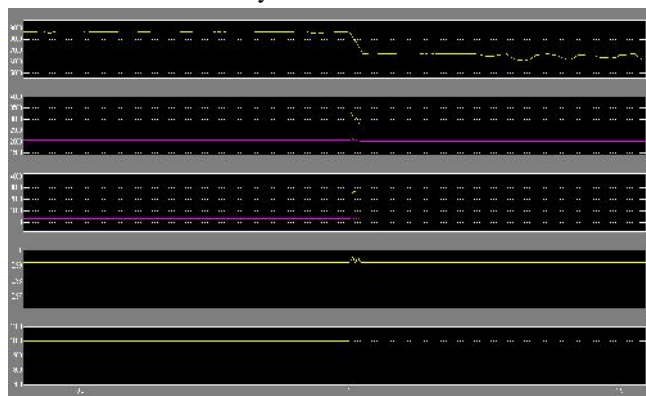

Fig 9 waveforms of PV power, VSC converter, active & reactive powers, power factor and irradiance of PV system

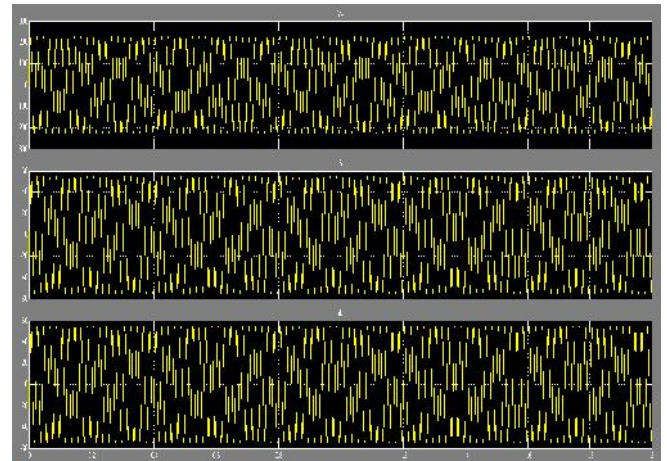

Fig 10 waveforms of source voltage, source current and load current

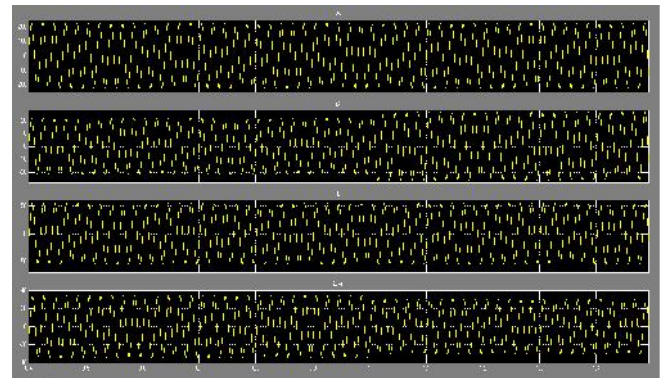

Fig 11 10 waveforms of source voltage, source current load current and DG system current

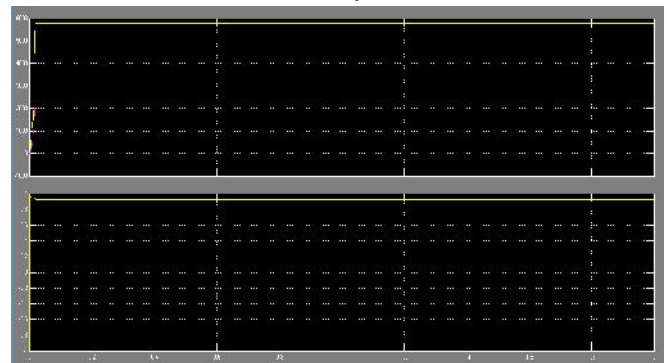

Fig 12 waveforms of active & reactive powers and power factor

CONCLUSION

The simulated results clearly demonstrates the ability of the proposed control scheme to evacuate MPP tracked power from the PV array and provide limited reactive power compensation with grid connected mode. The MPPT used in the control tracks the power very fast even under step change of insolation, and the current controlled PWM controller inject adequate generated current for self support of capacitor at DC bus and thereby providing storage less operation. Single phase SRF based

estimation is employed which provides rugged control with cost effective solution. The proposed SRF based approach enable the control for providing limited compensation of reactive power depending on available unutilized capacity of VSC. The implemented scheme derives the advantage of simplicity and is capable of delivering under varying insolation conditions effectively. Such technique is envisaged to benefit the PV rooftop system and grid/micro-grid by the limited compensation.

REFERENCES

1. Velasco de la Fuente, D. ; Garcera, G. ; Figueres, E. ; Guacaneme, J. "Reconfigurable control scheme for a PV microinverter working in both grid connected and island modes," IEEE Trans. Industrial Electronics, 2012.
2. Jmjun Liu ;Jun Yang ;Zhaoan Wang "A New Approach For Single- Phase Harmonic Current Detecting And Its Applicationin in a Hybrid Active Power Filter," IEEE conf., 1999.
3. B. Singh, V. Verma, "Selective compensation of power-quality problems through active power filter by current decomposition"IEEE Trans. Power delivery., vol. 23, no. 2, April 2008.
4. Guohong Zeng; Rasmussen, T.W.; Lin Ma; Teodorescu, R., "Design and of LCL-filter with active damping for Active Power Filter," IEEE International Symposium on Industrial Electronics, pp. 2657-2562, 2010.
5. S.Mekhilef, "Performance of grid connected inverter with maximum power point tracker and power factor control," International Journal of Power Electronics, vol. 1, pp. 49-62, 2008.
6. S.Mekh Femia, N.; Petrone, G.; Spagnuolo, G.; Vitelli, M., "A Technique for Improving P&O MPPT Performances of Double-Stage Grid-Connected Photovoltaic Systems," IEEE Trans. Industrial Electronics, vol. 56, pp. 4473-4482, 2009.
7. M. G. Villalava,j. r. Gazoli,E. Ruppert F., "Modelling and circuit –based simulation of Photovoltaic arrays" Brazilian Journal of Power Electronics,vol 14,no.4,pp. 35-45, 2009
8. B. Crowhurst, E.F. El-Saadany, L. El Chaar and L.A. Lamont "Single- Phase Grid-Tie Inverter Control Using DQ Transform for Active and Reactive Load Power Compensation," IEEE conf.,PECON, Malaysia, 2010.