



## Design Development and Analysis Of Two Wheeler Eco Friendly Plastic Carburetor With Rapid Prototyping

<sup>1</sup> P.Manasa Deepthi    <sup>2</sup> Gidda Venkateswara Rao    <sup>3</sup> J. Hari Narayana Rao

<sup>1</sup> M. Tech. Student,    <sup>2</sup> Assistant Professor

Dept Of ME, Godavari Institute of Engineering And Technology, Rajahmundry

<sup>3</sup> Reserch Scholar

**Abstract:** The design development and analysis of carburetor has been carry out by applying structural and thermal loads. The present work particularly deals with the drafting and designing of carburetor using plastic materials which can be manufactured with rapid prototyping to increase mass production. My main aim is to prevent the component from getting corroded or undergoing corrosion. Replacing metal components with plastic ones can offer some important bondage. Unlike metals, plastic materials can be modified to better suit. And also manufactured by using RP technique the life of the product increases of course when fuel injectors are replaced it as the main fuel input system, it had evolve into a complicated, sophisticated, expensive system. Carburetors are still found on automobiles, many small engines like those on lawn movers and model airplanes still use carburetors. It is to keep the cost of the engine down and it is very cheap to manufacture while fuel injectors requires more costly control systems.

### 1. INTRODUCTION

The designing of carburetor using plastic materials which can be manufactured with Rapid Proto Typing to increase mass production, to achieve cost reduction, to produce the component using best water absorption plastics. To prevent the component from getting corroded or undergoing corrosion. Not all materials are interchangeable, but there are several instances in which one material can be used in place of another to save money or improve performance. For example, a well-designed plastic part can often replace a metal part. Replacing metal components with plastic ones can offer some important advantages. Unlike metals, plastic materials can be modified to better suit a particular application, offering increased design options. Parts through of plastic can offer increased physical flexibility as well as equal or greater strength. Of course plastics can be much less expensive than metals, provided that significant savings, especially if

used in place of aluminum or stainless steel. Weight is another major issue. Plastic parts typically weigh a fraction of the metal parts they replace. Finally, plastics are corrosion resistant. Not like steel or aluminum, plastics will not oxidize over time. In adding, plastics with good high temperature resistance can be over-molded with rubber. For example, a metal part that includes a rubber seal can very likely be converted to plastic and rubber. materials Depends on application requirements, we utilize a wide range of Thermoplastic and thermo-set resins as alternatives to steel and aluminum. No material Metal, rubber or plastic will utility well in all environments, however. There may be Instances in which loading, temperature, chemical, or abrasion extremes make plastics Infeasible.

### 2. CARBURETOR

SI engines generally use volatile liquids. The preparation of the fuel-air mixture is done out side the engine cylinder. The fuel droplet that remain in suspension also continue to evaporate and mixed with air during suction and compression processes also. So carburetion is essential to provide a combustible mixture of fuel and air in required quantity and quality. The process of forming a combustible fuel-air mixture by mixing the right amount of fuel with air before admission to the cylinder of the engine is called carburetion and the device doing this Job is called carburetor and can also be explained as The carburetor is a device for atomizing and vaporizing the fuel and mixing it with the air in varying proportions to suit the changing conditions of spark ignition engines. The air-fuel mixture so obtained from the carburetor is also called as combustible mixture. The process of mixing the gasoline fuel with air to obtain the combustible mixture is called carburetion vaporization is the change of state of fuel from liquid to vapor. Atomization is the mechanical breaking-up of the liquid fuel into small particles (but not actually breaking-up into atoms, as

the name implies) so that every particle of fuel is surrounded by the air. In order to produce very quick vaporization of the liquid fuel, it is sprayed into the air passing through the carburettor. Spraying of the liquid turns into many fine particles, so that the vaporization occurs almost instantly.

### 3. AIR-FUEL MIXTURES

For accurate running of the engine under different loads and speeds a proper mixture of air and fuel is required. Generally three types of fuel mixtures are used like lean, rich and chemically correct mixture. The mixture in which there is just enough air for the complete combustion of the fuel is called stoichiometric mixture. The mixture which contains less air than the air required for stoichiometric mixture is called rich mixture and the mixture containing more air than the stoichiometric mixture is called lean mixture. The carburetor should provide the air-fuel mixture according to engine requirement and that must be under combustible range. The performance of an engine usually affected by the air-fuel ratio under which it is operating. The power output and the brake specific fuel consumption are affected by the air-fuel ratio as shown in the fig. The mixture equivalent to the maximum point on the power output curve is also called as best power mixture and the air-fuel ratio at this point is approximately 12:1. The mixture equivalent to the lowest point on the brake specific fuel consumption curve is called the economy mixture and the air-fuel ratio at this point is about 16:1. The best power mixture is generally richer than the stoichiometric mixture whereas the economy mixture is leaner than the stoichiometric mixture.

Following figure 3.1 shows the variation of mixture requirements from no-load to full-load in a S.I Engine.

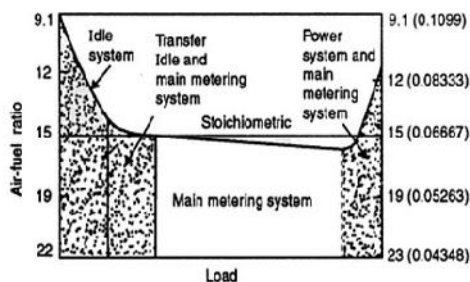

Fig. 3.1 Load vs Air fuel ratio

### 3.1 COMPENSATING DEVICES

The automobile has to run on different roads on different loads and conditions. The main metering system of the carburetor only will not be able to take care of the needs of the engines. Therefore, compensating devices are provided. The important compensating devices are

- Air-bleed jet
- Emulsion Tube
- Compensating jet
- Back suction control mechanism
- Auxiliary air port
- Auxiliary air valve

### 3.2. AIR-BLEED JET

The air bleed jet is present in the main nozzle. The flow of air through the orifice is restricted by and orifice. Initially, when the engine is not operating both the jets are filled with fuel. When the engine starts fuel comes out from both the nozzles but gradually the engine picks up and after that only air comes out of the air-bleed jet and mixes with the fuel coming out from the main nozzle and forms the fuel-air emulsion.

#### 3.2.1 EMULSION TUBE

The main metering jet is generally kept 25mm below the fuel level in the float chamber so as to avoid the overflow of the fuel. A jet is placed at the bottom of a well having holes which are connected to the atmosphere. When the throttle is opened fuel starts to flow from the well and the holes get uncovered and the air-fuel ratio increases i.e. the richness of the mixture decreases when all the holes get uncovered. The air is drawn through these holes and the fuel gets emulsified and the differential of pressure across the column of fuel is not as high as that of the simple carburetor.

#### 3.2.2 COMPENSATING JET

The main purpose of the compensating jet, which is connected to a compensating well, is to make the mixture leaner as the throttle valve opens gradually. The compensating well is vented to the atmosphere and is also connected to the main fuel chamber through a restricting orifice. With the

increase in air flow rate, the fuel level in the compensating well decreases so the fuel supply rate through the compensating jet also decreases. Thus the compensating jet tends to lean the mixture whereas the main jet tends to richen the mixture. So the sum of the two jets tends to keep the mixture to the required ratio.

### 3.2.3 BACK SUCTION CONTROL MECHANISM

In this device, the top of the fuel float chamber is linked to the entry part of the body of the carburetor by way of a long vent line fitted with a control valve. One more vent is linked from the top of the chamber to the venturi of the throat. When the control valve is completely open then pressure at the float chamber is similar as that of the air inlet. So there lies a pressure difference between the float chamber and the venturi and fuel from the float chamber flows into the venturi. But when the control valve is closed the pressure at the venturi and the float chamber are same and there is no fuel flow. Thus by proper control of the control valve a proper differential between the float chamber and the throat can be maintained and hence the quality of the mixture.

### 3.2.4 AUXILIARY VALVE

When the engine is in idle conditions the pressure at the top of the auxiliary valve is atmospheric. With increase in load, the vacuum at the throat of the venturi increases. So a pressure differential is created between the throat and the spring and this pressure difference raises the valve against the spring force. And as a result more air flows and the mixture becomes leaner.

### 3.2.5 AUXILIARY PORT

The auxiliary port connects the air entering part above the throat with the air leaving part below the throat by means of a long vent containing a butterfly valve. If the butterfly valve is opened then some additional amount of air passes through this vent and thus the flow of air across the venturi decreases.

## 4. PLASTICS

Plastics are used on a daily basis throughout the world. The word plastic is a common term that is used for many materials of a synthetic or semi-synthetic nature. The term was derived from the Greek word *plastikos*, which means "fit for molding." Plastics are wide variety of combinations of properties when viewed as a whole. They are used for shellac, cellulose, rubber, and asphalt. We as well synthetically produce

items such as clothing, packaging, automobiles, electronics, aircrafts, medical supplies, and recreational items. The list could go on and on and it is obvious that much of what we have today would not be possible without plastics. One way plastics changed the world was in cost. It was so much cheaper to manufacture than other materials and the various conduct it could be used was staggering. For in case, the use of polymers, which are substances with a higher molecule mass and which have a large number of repeating units, is common today. There are synthetic polymers, which are formed on a large scale and have many properties and uses. And there are naturally occurring polymers, which include starches, cellulose, proteins, and latex. Polymers are molecules (monomers) that join together like a chain with one or more monomers. The polymers are changed depending on the incorporation of these monomers. If the atoms in the monomers are combined with the polymer, it is called an addition polymer. When some of the atoms of the monomers are out into small molecules, as in liquid, then the polymer is also called as condensation polymer. A double bond between carbon atoms is most frequent in addition polymers. The physical structure of a polymer chain is significant, it determines the macroscopic properties. Conformation and configuration are terms used to describe the geometric structure of polymer. Configuration speaks to the order that is determined by chemical bonds and conformation speaks to the order that comes from the rotation of the molecules about the single bonds. Stereo regularity is the configuration of polymer chains. Three very different structures can be obtained: Isotactic, which is an arrangement of substituent's that are all on the same side of the chain. A syndiotactic chain is made up of alternating groups, and atactic is a combination that is random of all the groups.

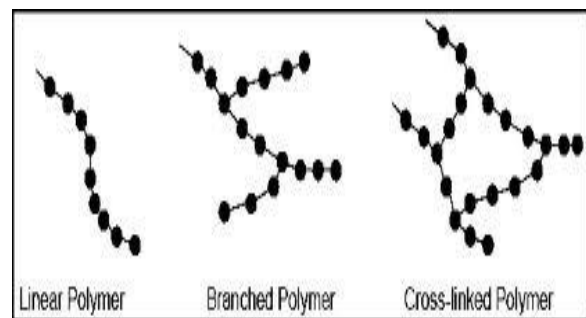

Because of their geometry, some polymers pack together tightly when the material is hard, this is called crystalline. Used in making items such as nylon, acetyl, polypropylene and polyethylene, crystalline polymers have superior properties, but do tend to considerably

shrink as they cool and re-harden. Usually, these polymers exhibit a sharp melting point, so when they are heated it takes a very low temperature to melt or become liquid, acting much like candle wax. The properties of plastic can also be altered. This can occur by modifying the polymers from the original, or changed by additives, colorants, reinforcement, or fillers. Additives must be compatible as there is always some sort of trade off when an additive is used. Chemists attempt to keep all of the other material properties as high as possible while still reaching the desired improvement, like a resistance to burning. Other additives may be used to improve high temperature stability, as flame-retardants or fungicides. Reinforcements get better strength with additives such as carbon, mica, glass and aramids, which may be in the form of mats, spheres, flakes, or other things such as filaments. Reinforcements in plastics allow them to be used for loads and at high temperatures, with greater stability dimensionally. This permits for more freedom in design and significant advances in technology in both the aviation and aerospace fields.

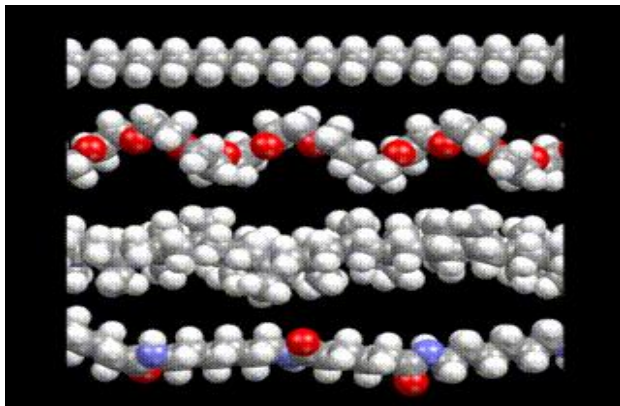

#### 4.1 PBT: POLY BUTYLENE TERAPHTHALATE

Polystyrene resin one of the manufacture trade point is due point. It is one of the polyester resin are based on PBT. By making physical technical modifications a wide range of products are available that are suited to enormous variety of industrial applications. In fact, this grooving family is currently available in over 100 different grades approximately half of which are flame retardant. PBT are tailored to reduce your molding cycle time with superior flow properties that variable filling of the mould at lower temperature among the many features of PBT grades are mechanical and physical properties of stiffness and toughness, heat resistance, excellent surface finish and good clarity. They have an excellent electrical insulation characteristics and high arc resistance grades are available. Processing is simple with good flow

properties, leading to short cycle time using standard injection molding machines, fastening gluvina, printing, painting, hot stamping and laser making are also available

\*water absorption = 0.08%

### 5. PRO-ENGINEERING

- Design Processing Technologies provides software solutions and services to world industry to help with the design during pre dimensioning and feasibility studies stages, in which 80 % of the risks on the production costs are committed.
- It the increase of competition, companies will continue to invest in the innovation to be more productive. Our products are able to accompany them in this step. We help the designers to conceive better and more quickly, by exploring more the domain of solutions. We address to the engineers poles of R&D in the sectors of cars and aeronautic as much as electrical and industrial components. Our products adapt to the problems of each field of engineering. Our expertise supports the capacity of the engineers to represent a product respecting a schedule of conditions.
- Design Processing Technologies has qualified and balanced team between research and industry. Our experts are able to adapt and solve your problems of preliminary design. Their professional experience allows a better comprehension of products development stages and the construction of a strong partnership relation.
- Considerable time savings in studies and dimensioning: Thanks to code generation and trial and error automation process, Pro-E DESIGN allows savings of time for a 3 to 10 factor in preliminary design.
- Huge reduction of total costs :
- Pro-E DESIGN makes it possible to optimize technical-economical models for technical performances improvement, reduction of manufacturing costs, product weight, dimensioning of whole product range or system using combination models and pooling of the constraints.
- Pro-E you to save time, and to make an analysis of the sensitivity of the solution.

#### 5.1.Features:

- Automatic code generation,
- Formal exact derivatives generation.
- Implicit or cyclic system handling.
- Uses a optimization algorithm to find a sizing.
- Sensibility and computing and drafting in pro@design-computer.
- Pro-E Design-optimize deals with hundreds of constraints by fixed value or interval.

## 5.2 Benefits:

- **Time and creativity:** No more program writing faster answer to model modification.
- **Time and optimization:** Helps the pro-E Design-optimize SQP based algorithm to find a solution where numerical derivatives fail.
- **Maintainability and knowledge management:** Easier to maintain than in computer program or spreadsheets. The knowledge is explicit, easier to capitalize, share and transfer.
- **Sizing of heavy constrained problems:** No input/output notions in the specification sheet. Hence, both inputs and outputs are constrained in Pro-E design-optimize.
- **Robust design:** Pro-E design-compute helps the designer to analyze the sensibility of the sizing solution.
- **Time and knowledge :** Enable the designer to analyze the sizing solution, and to evaluate the influence of optimization's parameters. Helps you to find the over constrained parameters in case of failure.

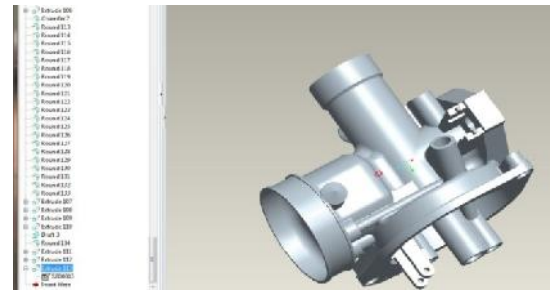
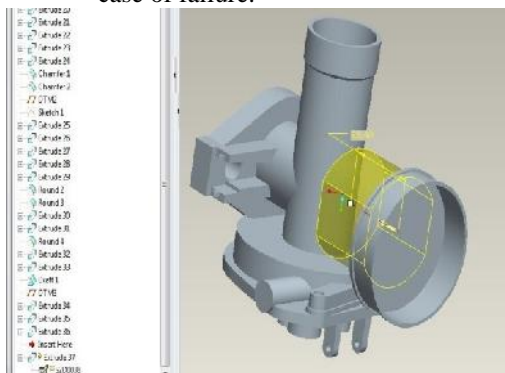

## 6. THE FINITE ELEMENT METHOD

The fundamental concept of FEM relies on the assumption that a discrete model can approximate any continuous quantity, such as temperature, pressure, or displacements. The model is composed of a set of piece wise continuous functions defined over a finite number of sub-domains ,in other words, FEM , indicates that every physical system can be thought of as consisting of several components or members or sub-members, each component contributing to the behaviour of the system as a whole. FEM equations can be derived using weighted residual methods like gallerkin's method, variational method or finite difference approximation. Most of the problems of solid mechanics in various branches of engineering are boundary value problem. Any solution to these problems must satisfy the following criteria.

- A: Field condition
- B: Boundary condition
- C: Approximate solutions

### Field conditions

Differential equation and one or more partial differential equations are usually obtained by vectorial treatment of the principles of mechanics. These equations from the governing equations that the field variables must satisfy for equilibrium and compatibility conditions, of the solid or structural system. These differential equations can also be obtained by using Euler lagrange equations of the variational principle.

Variational Formulation-In this approach, the extreme value of the functional is sought as the solution to the problem. The governing functional may be the total potential energy or total complementary energy of the system. Using the calculus of variations ,it can be shown that extreme value of the functional is obtained by equating the first variational of the functional to zero.

### Boundary Conditions

For structural problems, the boundary conditions may be kinematic i.e, where the displacements may be prescribed, or static, i.e, where forces may be prescribed.

## 7 .RESULTS

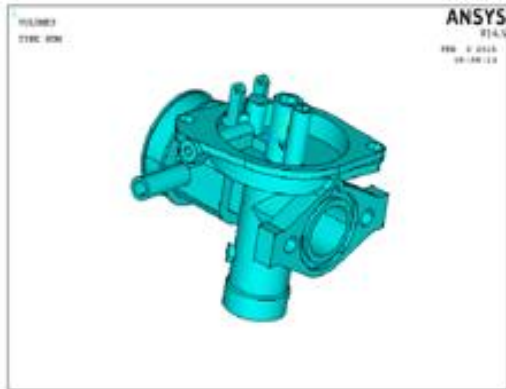

Fig

7.1 Design of Carburetor When Imported to ANSYS



Fig 7.2 Deformed shape of the carburetor in ANSYS



Fig 7.3 Meshed shape of Carburetor in ANSYS

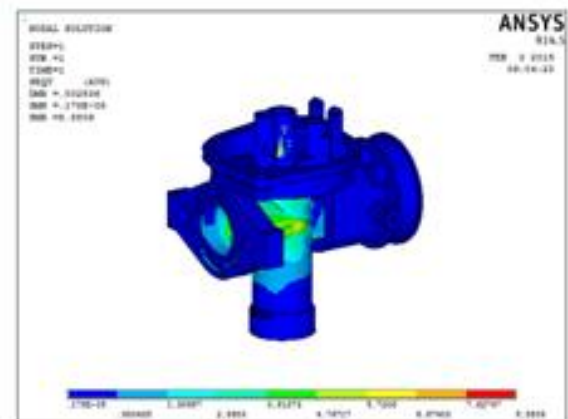

Fig 7.4 Stresses of Carburetor in ANSYS

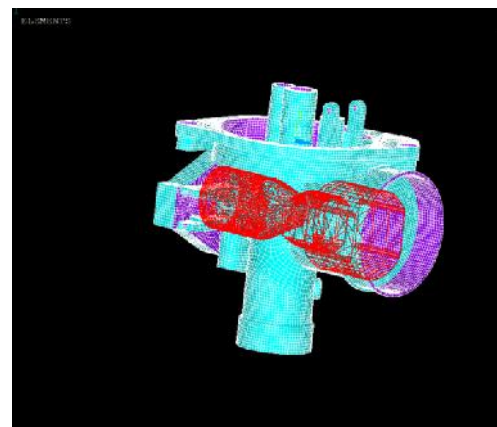
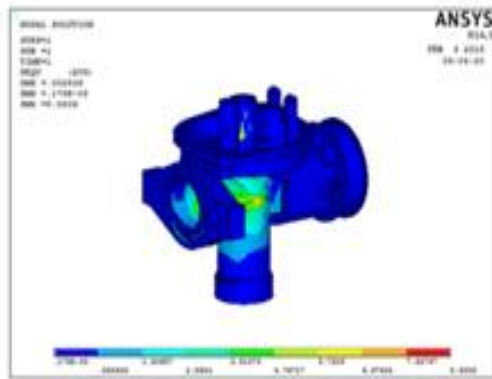
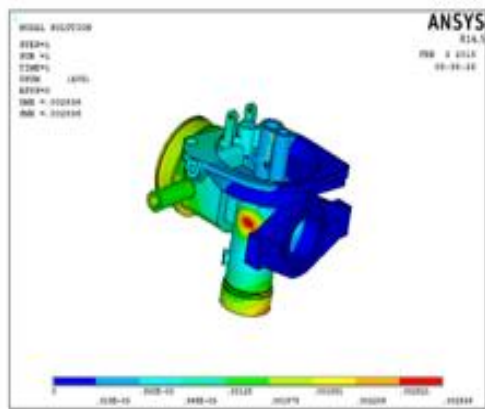

Fig 7.5 When pressure is applied



**Fig 7.6 VON MISES Stresses of Carburetor in ANSYS**



PRESSURE : 0.345 BAR

TEMPERATURE: 70degree

NODE APPLIED : 4NODESOLID 181

### 7.1 RAPID PROTOTYPING

RP has observable use as a vehicle for visualization. In addition of, RP models can be used for testing, such as when an airfoil shape is put into a wind tunnel. RP models can be use to create male models for tooling, such as silicone rubber molds and investment casts. In several cases, the RP part can be the final part, but typically the RP material is not strong or accurate enough. When the RP material is suitable, highly convoluted shapes can be produced because of the nature of RP.

There is a multitude of experimental RP methodologies either in development or used by small groups of individuals. This section will focus on RP

techniques that are currently commercially available, including Stereo-lithography (SLA), Selective Laser Sintering (SLS®), Laminated Object Manufacturing (LOM™), Fused Deposition Modeling (FDM), 3D printing, and Ink Jet printing techniques

### 7.2 METHODOLOGY OF RAPID PROTOTYPING

The basic methodology for all current rapid prototyping techniques can be summarized as follows:

- 1.A CAD model is constructed, and then converted to STL format. The resolution can be set to minimize stair stepping.
- 2.The RP machine processes the .STL file by creating sliced layers of the model.
- 3.The first layer of the physical model is created. The model is then lowered by the thickness of the next layer, and the process is repeated until completion of the model.
- 4.The model and any supports are removed. The surface of the model is then finished and cleaned

#### Conclusion

The project is to develop a plastic carburetor using Rapid-Prototyping, as we see the results in the analysis we can observe the stress and the deformation of carburetor is very low and even if the manufacturing of the carburetor is done through Rapid Prototyping, the life of the carburetor also increases. So from all the results obtained we can conclude that the carburetor which is made with plastic by Rapid Prototyping process gives the better life and efficiency than others.

#### References:

1. Klkuo Tanabe, Takashi senior and yoshihiro Kajlo, “characteristics of carbon/glass Fiber Reinforced Plastic leaf spring”, Journal of SAE Tech 820403
2. Morris C.J, “composite integrated rear suspension”, Journal of composite structures.
3. Carlisle, Rodney (2005), Scientific American Inventions and Discoveries: All the Milestones in Ingenuity--From the Discovery of Fire to the Invention of the Microwave Oven, John Wiley & Sons, p. 335, ISBN 9780471660248, retrieved July 27, 2014
4. Rigden, John S.; Stuewer, Roger H. (2009). The Physical Tourist: A Science Guide for the Traveler. Springer. ISBN 9783764389338. Retrieved 19 January 2014.

5. "Donát Bánki". Scitech.mtesz.hu. Archived from the original on 17 July 2012. Retrieved 19 January 2014

6. Aumann, Mark (11 January 2012). "NASCAR takes 'really big step' with fuel injection". Nascar.com. Archived from the original on 25 October 2012. Retrieved 19 January 2014.

7. Hillier, V.A.W.; Pittuck, F.W. (1966). "Section 3.6". *Fundamentals of Motor Vehicle Technology* (Second ed.). Hutchinson Educational. ISBN 9780091107116.