



Power Flow Management In A Fuzzy Logic Control Of Solar PV System Supplying DC And AC Loads

¹Phani Kumar Nallajerla ²K V Sai Kumar ³K Dhana raju

1,2,3 Dept of EEE, Kakinada Institute of Engineering and Technology, Korangi, Kakinada, EGDST, AP.

ABSTRACT:

PV based systems are being more and more in employment in diverse applications both at domestic and commercial levels. Photovoltaic systems can be largely confidential into stand-alone system and grid-connected system. The stand-alone system is extensively used in remote places where access to electricity is not viable. The stand-alone configuration can make available a well-regulated load voltage but the dependability of power supply cannot be sure-fire. Storage batteries are generally used to recover the reliability of the stand-alone system. The incorporation of a PV system to the grid is speedily growing due to the development in the power electronics technology. And proposed add on called FUZZY logic to basic MPPT so that the good organization of PV system under above said circumstances is establish productive. A variety of topologies and control strategies for grid-connected inverters have been narrative. In grid-connected PV systems (GCPVs) the generated PV power is fed to the grid or it provisions the linear and nonlinear loads connected at the ac side.

KEYWORDS: Bidirectional converter, dc bus, photovoltaic, power flow management system (PMS), fuzzy logic controller.

INTRODUCTION:

A grid-connected PV system engrosses a power source (PV array), a power sink (load) and two power sources/sink (utility and battery) and for this reason a power flow management system is requisite to equilibrium the power flow among these sources. One such system is developed for selecting the operating mode of the bidirectional converter by sensing the battery voltage. The feasibility of the scheme has been established by performing experimental studies on a laboratory prototype. The control strategy is digitally executed on an Altera Cyclone II Field Programmable Gate Array (FPGA) board and the algorithm is verified for different modes of operation by varying the load. Experimental results are presented to bring out the usefulness of the control strategy. The growing concern for energy saving has greater than before the usage of LED-based street lights,

electronic chokes, compact fluorescent lamps and inverter-fed drives. Therefore the load profile seen by the electrical grid is experience a notable change as these devices have to function from a dc source. Photovoltaic's (PV) being a major energy source.

RELATED WORK:

The stipulate for power is growing beyond the planner's assessment and the power grid is weak and scheduled power outages throughout the year are common. In calculation there are also spontaneous short-term outages which are casual and recurrent. As a result a grid-connected PV system with a battery backup has much compensation such as peak shaving to generate power during peak load hours and consequently the grid-side inverter should operate in grid-tied mode and off-grid mode to supply uninterrupted power to the critical loads during power outages. In some applications a battery was connected directly in parallel with the dc bus. The size of the battery can be reduced when a battery charger/discharger circuit is inserted between the dc bus and the battery. Make use of the battery charger/discharger circuit for regulating dc link voltage decouples the dc link control from the ac current control and accomplishes faster regulation of dc link voltage.

EXISTING METHOD:

In some hybrid systems battery is used to recompense the mismatch between the generation and demand. In developing countries the demand for power is rising beyond the planner's estimation and the power grid is weak and planned power outages throughout the year are common. In addition there are also spontaneous short term outages which are arbitrary and recurrent. The variation in PV power will cause variation in dc link voltage which is regulated by adjusting the ac line current amplitude and under grid failure. A separate controller is required to regulate the dc bus voltage.

DISADVANTAGES:

The variation in loads also affects the dc bus voltage. The variation in the dc link voltage causes

a proportional change in the ac line current. This causes the line current amplitude to differ frequently leading to poor power quality. Moreover when the solar radiation is less the power quality is degraded as the total harmonic distortion (THD) of the line current is inversely proportional to the power injected into the grid.

PROPOSED METHOD:

When the solar radiation is fewer the power quality is besmirched as the total harmonic distortion (THD) of the line current is inversely proportional to the power injected into the grid. In addition the disturbance in dc link voltage is reflected in PV array power and the PV operating point shifts from the maximum power point (MPP). Therefore a fast regulation of dc link voltage is essential to make sure constant dc voltage while concurrently maintaining the THD of the current injected into the grid within the standard limits. A challenge was made to supply consistent power to the loads connected at the dc side. When the generated PV power is more than the load demand only the load power demand is met by the PV and the overload PV power is not fed to the grid. Simple MPPT methods are most usually utilized to meet load demands in the case of shadows, low intensity of sunlight on the PV plates but its competence is incomplete. Hence to overcome it proposed add on called FUZZY logic to basic MPPT so that the good organization of PV system under above said circumstances is establish productive.

ADVANTAGES:

Good power quality. Use of fuzzy logic controller with improved in general efficiency of the system. The bi-directional power flow provides better chances to harvest energy. It can be used as single input multi output system. Provision of multi type powers i.e. DC & AC.

SYSTEM ARCHITECTURE:

The PV system consists of a PV array, a boost converter, a battery storage unit with its charger/discharger circuit and a bidirectional converter to line with the grid and the schematic of the PV system is shown. A boost converter is used to pathway the highest power from the PV array and a dual H-bridge bidirectional converter (battery charger/discharger) proficient of operating in both buck and boost modes of operation is utilized to normalize the dc link voltage. The PV system concentrates on condition that a continuous power supply to the loads connected at the dc side and the grid is used as a backup means when there is inadequate PV power and go together the grid

when excess PV power is accessible. This requires the bidirectional converter to have three operating modes namely idle mode (grid is disconnected), inverter mode and rectifier mode. The battery is charged either from PV or grid depending upon the accessibility of the PV power and load demand. The voltage control loop of the charger/discharger circuit establishes the charging/discharging mode of the battery. The PV system engages three energy sources PV, battery and grid, and a PMS balances the power flow among these sources.

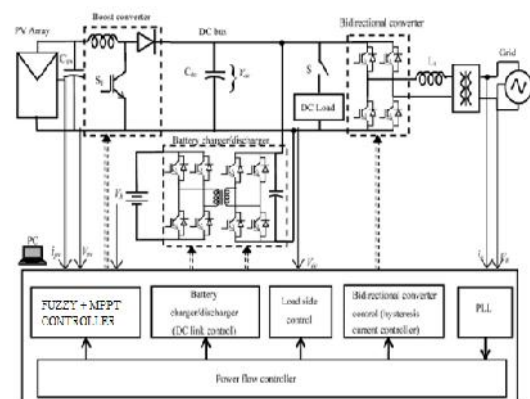

Schematic of the bidirectional converter with proposed control

FUZZY LOGIC CONTROLLER:

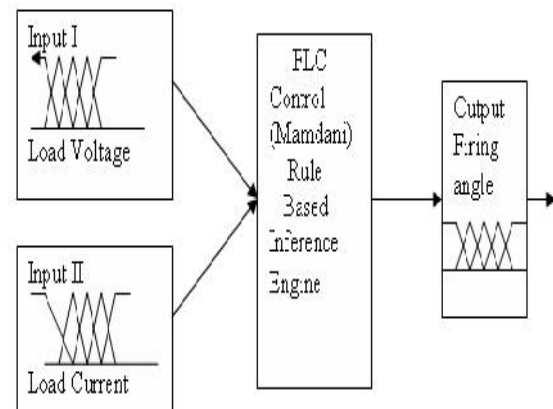

Mamdani's fuzzy inference method is the most commonly seen fuzzy methodology. Mamdani's method was among the first control systems built using fuzzy set theory. *Mamdani-type inference* defined for the toolbox expects the output membership functions to be fuzzy sets. After the aggregation process there is a fuzzy set for each output variable that needs defuzzification.

CONTROL STRUCTURE:

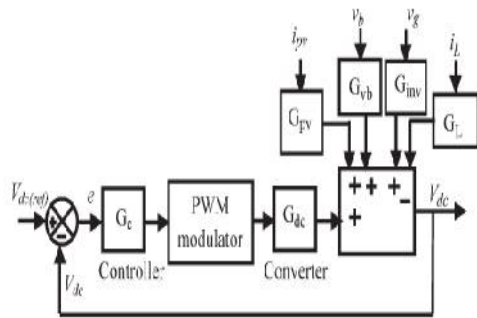

The control structure of the system is shown where V_{dc} is synchronized by the charger/discharger circuit. The converter control to output transfer function G_{dc} is expressed shown at the bottom where r_s is the resistance of the battery, C_1 and C_2 are the input and output capacitances correspondingly. L is the leakage inductance of the transformer, f_{sw} is the switching frequency and d is the phase shift between the two bridges.

$$G_{dc}(s) = \frac{v_{dc}(s)}{d(s)} = \frac{(s + 2/r_s C_1) [(2d - 1) 2V_1 (3C_2 - C_1)] / (f_{sw} L C_1 C_2)}{s^2 + (2/r_s C_1 + 2/r_s C_1) s + 4 / R r_s C_1 C_2 + (2d^2 - 2d)^2 / f_{sw}^2 L^2 C_1 C_2}$$

METHODOLOGY:

PV SYSTEM:

The photovoltaic achievement of the selenium diverted from its photoconductive action in that a current was fashioned impulsively by the action of light. No external power supply was needed. In this early photovoltaic device a remedy junction had been formed among the semiconductor and the metal contact. Photovoltaic became ready for action in contexts where conventional electricity supply is most expensive. For illustration for remote low power applications such as navigation, telecommunications and rural electric action and for enhancement of supply in grid-connected loads at peak use. The current produced is straight dependent on the concentration of light reaching the module. Several modules can be wired together to form an array. Photovoltaic modules and arrays produce direct-current electricity. They can be coupled in both series and parallel electrical arrangements to fabricate any required voltage and current combination.

TRANSFORMER LESS INVERTER:

The major recent shift in inverter technology is the accessibility of transformer less inverters. They have long been popular in Europe but now most inverter manufacturers have supplementary a

transformer less option to their existing inverter line. Without a heavy transformer they evaluate about 50% to 70% less than a transformer-based inverter of similar output and the size of the inverter housing can be compact. Inverter competence is also greater than before there are no longer losses linked with having a transformer to step up the voltage. And because the transformer which is encompass of copper windings on an iron or steel core is eliminated they are less expensive to produce.

SPWM:

SPWM (Sinusoidal Pulse-Width Modulation) method is based on classical SPWM technique with carriers and position sine waveform. Only difference between them is in digital SPWM a sine table consisting of values of sine waveform sampled at convinced frequency is used. As result reference wave form in digital SPWM represents a sample and hold wave form of sine wave form. A simple comparator with a saw tooth carrier can revolve a sinusoidal command into a pulse-width modulated output. By increasing or decreasing pulse width the controller regulates energy flow to the motor shaft. The motor's own inductance acts like a filter storing energy during the "on" cycle while releasing it at a rate corresponding to the input or reference signal. In other words energy flows into the load not so much the controlling frequency but at the orientation frequency.

PWM:

Pulse-width modulation (PWM) is the foundation for control in power electronics. The hypothetically zero rise and fall time of an ideal PWM waveform symbolizes a preferred way of driving modern semiconductor power devices. Pulse-width modulation can take different forms. The pulse frequency is one of the most significant parameters when defining a PWM method and can be either constant or variable. A constant-frequency (CF) PWM signal can be shaped simply by comparing a reference signal, $r(t)$, with a carrier signal, $c(t)$. The binary PWM output can be mathematically written as

$$b_{pwm}(t) = \text{sgn}[r(t) - c(t)],$$

Where 'sgn' is the sign function.

EXPERIMENTAL RESULTS:

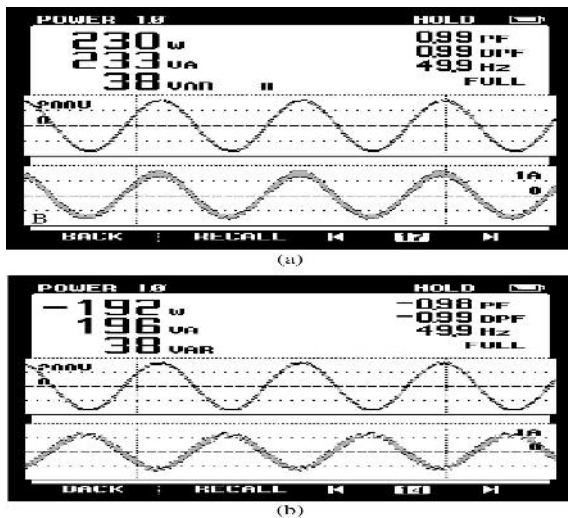

Steady-state response (a) Rectifier mode. (b) Inverter mode.

The grid voltage and line current are in phase representative that the converter is operating in rectifier mode and supplies 230 W at 0.99 power factor. The THD of the line current is found to be 3.7%. The steady-state performance of the system in the inverter mode and a 192-W power is nourished to the grid from the PV. The THD of the line current in this mode is found to be 4.1%. It can be experiential that a near unity power factor is achieved in both the rectifier and inverter modes of operation. In both the modes of operation the minimum current is set as 1 A by the PMS. Under any operating mode the injected current is more than the minimum value and as a result the THD will always be less than the standard limit of 5%.

CONCLUSION:

A versatile control strategy for power flow management in a grid-connected PV system feeding dc loads has been simulated by using Matlab/Simulink model design software. The steady-state performance of the converter for different modes of operation has been observed, and near unity power factor has been achieved in both the rectifier and inverter modes. The transient performances of the system for step changes in load and insolation have been also illustrated. The presence of Fuzzy system made system less sensitive to changes in input. This intern made system more stable and reliable.

REFERENCES

[1] Yazdani and P. P. Dash, "A control methodology and characterization of dynamics for a photovoltaic system interfaced with a distribution

network," *IEEE Trans. Power Del.*, vol. 24, no. 3, pp. 1538–1551, Jul. 2009.

[2] X. Q. Guo and W. Y. Wu, "Improved current regulation of three-phase grid-connected voltage-source inverters for distributed generation systems," *IET Renew. Power Gener.*, vol. 4, no. 2, pp. 101–115, Mar. 2010.

[3] H. C. Chiang, T. T. Ma, Y. H. Cheng, J. M. Chang, and W. N. Chang, "Design and implementation of a hybrid regenerative power system combining grid-tie and uninterruptible power supply functions," *IET Renew. Power Gener.*, vol. 4, no. 1, pp. 85–99, Jan. 2010.

[4] F. Giraud and Z. M. Salameh, "Steady-state performance of a gridconnected rooftop hybrid wind–photovoltaic power system with battery storage," *IEEE Trans. Energy. Convers.*, vol. 16, no. 1, pp. 1–7, Mar. 2001.

[5] J. M. Carrasco, L. G. Franquelo, J. T. Bialasiewicz, E. Galván, R. C. P. Guisado, M. A. M. Prats, J. I. León, and N. Moreno-Alfonso, "Power electronic systems for the grid integration of renewable energy sources: A survey," *IEEE Trans. Ind. Electron.*, vol. 53, no. 4, pp. 1002–1016, Aug. 2006.

[6] B. Kroposki, C. Pink, R. DeBlasio, H. Thomas, M. Simões, and P. K. Sen, "Benefits of power electronic interfaces for distributed energy sources," *IEEE Trans. Ind. Electron.*, vol. 25, no. 3, pp. 901–908, Sep. 2010.

[7] H. M. Kojabadi, B. Yu, I. A. Gadoura, L. Chang, and M. Ghribi, "A novel DSP-based current controlled PWM strategy for single phase grid connected inverters," *IEEE Trans. Ind. Electron.*, vol. 21, no. 4, pp. 985–993, Jul. 2006.

[8] J. C. Moreno, J. M. Espi Huerta, R. G. Gil, and S. A. Gonzalez, "A robust predictive current control for three-phase grid-connected inverters," *IEEE Trans. Ind. Electron.*, vol. 56, no. 6, pp. 1993–2004, Jun. 2009.

[9] Z. Yao, L. Xiao, and Y. Yan, "Seamless transfer of single phase grid interactive inverters between grid connected and standalone modes," *IEEE Trans. Power Electron.*, vol. 25, no. 6, pp. 1597–1603, Jun. 2010.

[10] M. Singh, V. Khadkikar, A. Chandra, and R. K. Varma, "Grid interconnection of renewable energy sources at the distribution level with powerquality improvement features," IEEE Trans. Power Del., vol. 26, no. 1, pp. 307–315, Jan. 2011.

[11] S. Yang, Q. Lei, F. Z. Peng, and Z. Qian, "A robust control scheme for grid-connected voltage-source inverters," IEEE Trans. Ind. Electron., vol. 58, no. 1, pp. 202–212, Jan. 2011.

[12] F.-S. Pai, J.-M. Lin, and S.-J. Huang, "Design of an inverter array for distributed generations with flexible capacity operations," IEEE Trans. Ind. Electron., vol. 57, no. 12, pp. 3927–3934, Dec. 2010.



Mr. Phani Kumar Nallajerla is a student of KAKINADA Institute of Engineering & Technology (KIET), Kakinada. Presently he is pursuing his M.Tech [Power Electronics] from this college and he received his B.Tech from NOVA College of Engineering & Technology, Jangareddygudem, affiliated to JNT University, Kakinada in the year 2011. His area of interest includes power quality enhancement and FACTS, all current trends and techniques in Electrical engineering.



K .V. Sai Kumar, is an excellent teacher, Received M.Tech (PS& A) from Gitam university and have been working as Assistant Professor , Department of Electrical & Electronics Engineering , KAKINADA Institute of Engineering & Technology(KIET), Kakinada. He has 6 years of teaching experience in various engineering colleges. To his credit couple of publications both national and international conferences /journals . His area of Interest includes Power systems and Automation, FACTS, and other advances in Power quality Applications.



K. Dhana raju, Received M.Tech (EPE) from Sree nidhi institute of science & technology (SNIST),Ghatkesar. Presently he is pursuing his Ph.D in JNTU KAKINADA and Have been working as Assistant Professor , Department of Electrical & Electronics Engineering , KAKINADA Institute of Engineering & Technology(KIET), Kakinada. He has 6 years of teaching experience in various engineering colleges. To his credit couple of publications both national and international conferences /journals . His area of Interest includes Power systems, Fault analysis and FACTS.