



International Journal of Science Engineering and Advance Technology

A New Algorithm for Distributed Generator (DG) Placement and Sizing for Distribution Systems

U.Krishna Chaithanya¹, M.Sreenivasulu², Sk.Jan Bhasha³

PG Student [EPS], Assistant Professor *Associate Professor*,
Dept. of EEE, ASIT, Gudur, SPSR Nellore (D), Andhra Pradesh, India³

ABSTRACT— In today's distribution grids the number of distributed generation units is increasing rapidly. Combined heat and power (CHP) plants and wind turbines are most often installed. Integration of these DG units into the distribution grid leads to planning as well as operational challenges. In this paper proposed a new algorithm for Distributed Generator (DG) placement and sizing for distribution systems based on a novel index. The index is developed considering stable node voltages referred as power stability index (PSI). A new analytical approach is adopted to visualize the impact of DG on system losses, voltage profile and voltage stability. The proposed algorithm is tested on 12-bus, modified 12-bus and 69-bus radial distribution networks. The test results are also compared and found to be in close agreement with the existing Golden Section Search (GSS) algorithm.

Index terms: FACTS, optimal location, Power flow, UPFC.

1. INTRODUCTION:

Inderegulation of power system, Distribution Generation (DG) plays an important role in the present scenario. The increased power demand and to meet out the peak load demand in the distribution system, DGs are greatly utilized. By placing an optimal location with optimal size of DGs, the real and reactive power losses due to transmission are minimized and also peak load demand is appreciably shared by these DGs. this decade with the deregulation of the electricity market, the traditional concepts and practices of power systems are changed. The functions to find the optimal allocation of DG based on real and reactive power losses, line loading, voltage profile, short circuit level index and MVA (Mega Volt Ampere) intake by grid for different load models. Each load model has a significant impact on selecting size and location of the DG.

However there are several issues concerning the integration of DGs with existing power system networks; that needs to be addressed [3-5]. The integration of DG changes the system from passive to active networks, which affects the reliability and operation of a power system network [4]. Furthermore, the non-optimal placement of DG can result in an

increase of the system losses and thus making the voltage profile lower than the allowable limit [6]. Since utilities are already facing technical and non-technical issues, they cannot tolerate such additional issues. Hence an optimum placement of DG is needed in order to minimize overall system losses and therefore improve voltage profiles.

Optimization based algorithms have also been proposed by different authors. In [7], the author used the loss sensitivity equation to determine the optimum size of DG and the exact loss equation to determine the optimum location of DG based on minimum losses. In [8], the authors presented analytical approach to determine the optimal location for the DG with an minimization for distribution and transmission networks. In [9], the author presented the loss sensitivity factor based onequivalent current injection using two Bus-Injection to Branch-Current (BIBC) and Branch-Current to Bus-Voltage (BCBV) matrix. A simple search algorithm is proposed in [10] for optimal sizing and placement of DG for a network system. In [11], ACS (Ant Colony Search Algorithm) is used here to find the optimal placement of DG and re-closers based on system reliability. Particle Swarm Optimization algorithm is used in [12, 13] for optimum placement considering the minimum electricity cost for consumers. In [14], authors have presented the dynamic based programming approach to find the best location for DG with maximum profit as an objective function. Genetic Algorithm (GA) based methods are proposed in [15-17] for optimal sizing and placement of DG, considering different objective functions. GA-Fuzzy based optimal placement of DG is discussed in [2], considering multi-objective functions including system losses, system loading as well as the profit for DISCOs (Distribution Companies). In [18], the author has presented the combine GA and PSO based approach for optimal location and capacity of DG, considering multi-objective constraints like voltage stability, losses and improved voltage regulations. GAs based methods are slow in computation and convergence particularly useful when multi-objective conditions are considered.

This paper proposes a new method for DG placement and sizing based on the line voltage stability index. Previously the author in [19] has used the continuation power flow method to determine the most voltage-

sensitive bus in the distribution system which could result in voltage instability in the system. DG is placed on the identified sensitive bus and the size of DG on that bus is increased gradually till the objective function (voltage constraints) is achieved. The proposed algorithm is also working on the same objective function for DG allocation. The developed index is used to identify the most critical bus in the system that can lead to system voltage instability when load increase above certain limit. The DG is placed at the identified bus. The search algorithm is used for estimating the size of DG considering minimum network losses. Overall, this proposed method is simpler and requires less computational time for determining the optimum placement and size of DG as compared to classical search algorithms.

2.1 IMPACT OF DG PLACEMENT-NEW APPROACH:

The following factors are considered in the placement and sizing of DG.

1. Reduction in line losses.
2. Improvement in voltage profile and stability.

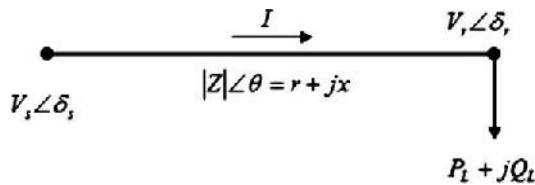

Fig. 1a. A two bus network.

From the phasor diagram, we can write:

$$\bar{V}_r = \bar{V}_s - I\bar{Z} \quad (1)$$

If we reduce the IZ component in the Eq. (1), the receiving end voltage can be improved. There are three ways to reduce the IZ components.

1. Provide active power support to the system locally using renewable energy or distributed resources or FACTS (in the present case we are considering the impact of DG only).
2. Provide reactive power support to the system locally using static condensers or FACTS.

3. Use of Anti Z element, which is only possible through series capacitance

Fig. 2a shows the active power support to the system locally. The phasor diagram is shown in Fig. 2b, which shows that the introduction of DG will reduce the active line component of the current from I to I' to I'' (I > I' > I'') as the DG size will increase. This will result in lesser I_r and I_x drop.

Fig. 3a shows the scenario when we provide reactive power to the system. This will reduce the

reactive current component from I to I' to I'' (I > I' > I'') shown in phasor diagram Fig. 3b, which will result in lesser I_r and I_x drop.

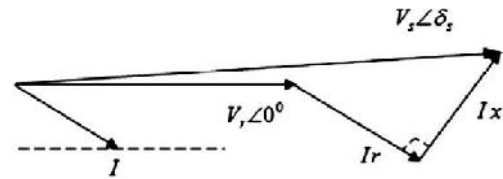

Fig. 1b. Phasor diagram of a simple two bus network.

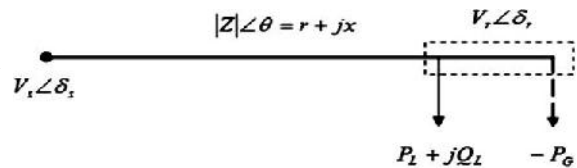

Fig. 2a. Active power support

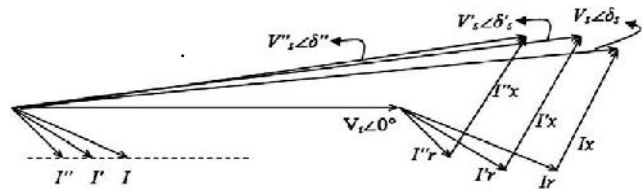

Fig. 2b. Phasor diagram for active power support

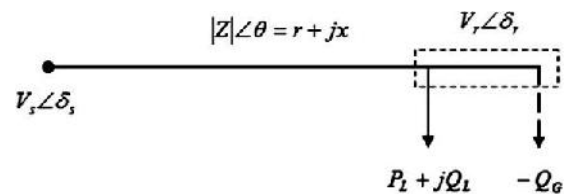

Fig. 3a. Reactive power support

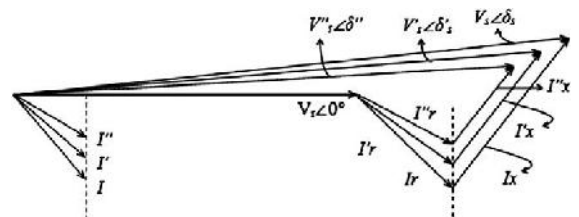

Fig. 3b. Phasor diagram for reactive power support.

The losses that occurs in the line is given by

$$P_e - jQ_e = I^2(r + jx) \quad (2)$$

where P_e is the active power loss; Q_e the reactive power loss

The line current, given by:

$$I = \frac{V_s\angle\delta_s - V_r\angle\delta_r}{r + jx} \quad (3)$$

From Figs. 2a and 3a we can write:

$$[V_r \angle \delta_s - V_s \angle \delta_r]^2 = (P_e - jQ_e)(r + jx) \quad (4)$$

From Eq. (2) and Eq. (3), we can conclude that

1.The line resistance and reactance play a very crucial role for voltage stability.

2.The line losses (or current) should be reduced for stable and improved voltages, which is only possible by providing active and reactive power support to the system Therefore the most suitable site and size of DG should be selected from where the maximum benefits could be achieved.

In [20], the author used the following mathematical formula-tion which needs to be considered in DG placement.

Minimize total active powe losses P_L

$$Mi \{P_L = \sum_{i=1}^n |I_i|^2 R_i\} \quad (5)$$

Subject to the following generation and voltage constraints:

$$0 \leq P_{dg} \leq \sum P_{load} \quad (6)$$

$$|V_i \min| \leq |V_i| \leq |V_i \max| \quad i = 1, 2, \dots, m \quad (7)$$

where n is the no. of lines; m the no. of buses; P_{dg} the distributed generation power; and P_{load} is the total connected load.

The main constraints as defined in Eqs. (6-7) are to restrain the voltages at each bus along the radial system within the acceptable range and the total active power support should not exceed the system load.

3.PROPOSED CONCEPT:

The main factor in maintaining the voltage between two nodes is the drop in the line connecting the two nodes, commonly known as voltage regulation. Ideally voltage regulation should be zero, but there are drops due to resistance and reactance of a line. In transmission lines, resistance is much less than the reactance of the transmission lines ($r \ll x$); while in overhead distribution system, reactance is much less than the resistance of the line ($x \ll r$). There is no anti- resistance element which could improve the volt-age regulation. The series capacitor is commonly connected in long transmission lines having high reactance than a distribution network, in order to improve the voltage profile and increasing the system efficiency. However by supporting the active and reactive power demands locally could significantly reduced the voltage drop in the line by reduction in line current and losses and thus im-proves the system efficiency.

3.1 Procedure of DG placement Index:

Consider a simple two bus network without and with DG shown in Figs. 1a and 2a, with their phasor diagram also presented in Figs. 1b and 2b.

From fig. 1 we can write

$$S_L = P_L + jQ_L = V_r I_r^* \quad (8) \quad \bar{V}_r = \bar{V}_s - I_r \bar{Z} \quad (9)$$

Where

$$I_r = \frac{P_L - jQ_L}{V_r^*} \quad (10)$$

From fig 2a and 3a

$$I_r = \frac{(P_L - P_G) - j(Q_L - Q_G)}{V_r^*} \quad (11)$$

Substitute I_r from Eq. (11) into Eq. (9) and separate into real and imaginary parts will give:

$$P_L - P_G = \frac{|V_r||V_s|}{V_r^*} \cos(\theta - \delta_s + \delta_r) - \frac{|V_r|^2}{Z} \cos(\theta) \quad (12)$$

$$Q_L - Q_G = \frac{|V_r||V_s|}{V_r^*} \sin(\theta - \delta_s + \delta_r) - \frac{|V_r|^2}{Z} \sin(\theta) \quad (13)$$

Rearranging eq (12) give

$$|V_r|^2 = \frac{|V_r||V_s| \cos(\theta - \delta)}{\cos(\theta)} + \frac{Z(P_L - P_G)}{\cos(\theta)} = 0 \quad (14)$$

Where

$$\delta = \delta_s - \delta_r$$

The Eq. (14) is a quadratic equation. For stable node voltages, Eq. (14) should have real roots, i.e. discriminant $B^2 - 4AC > 0$, which results in the proposed index referred as Power Stability Index (PSI) given by Eq. (15)

$$PSI = \frac{4r_{ij}(P_L - P_G)}{[|V_i| \cos(\theta - \delta)]^2} \leq 1 \quad (15)$$

The PSI value is calculated for each line in the given network and sorted from the highest to the lowest value. For the i - j line having the highest value of PSI, the DG should be placed at j-bus. For multi DG placement, the location of the second DG will be based on the effect of first DG on PSI. PSI

The DG will be placed at the end of the line having the highest value of PSI.

3.2 Maximum sizing of DG:

Once the optimum location of DG is identified, the amount of active power from DG changes from 0% to 100% of the total active load, with generation and voltage constraint given in Eqs. (6-7). The main objective in selecting DG size is to minimize total system power losses (Ploss) by injecting active power (Pdg), given in PSI Equation. The relation between DG size and losses follow the parabolic curve, first decreases and then start increases, thus the accuracy of the DG size estimated will depend on the step size

selected. In the present case, the step size is maintained 1% of total load. However much smaller size could also be used, but the computation will take much longer time.

3.3 Proposed Algorithm:

For a radial distribution network, load flow analysis is carried out and PSI value is computed for each line using PSI equation. For $i - j$ line having the highest value of PSI, the DG will be placed at j th bus. The search algorithm is used for finding the optimum size of DG at optimum location based on a minimum total power loss, with constraints. The complete flow chart for DG allocation and sizing is represented in Figure. 4.

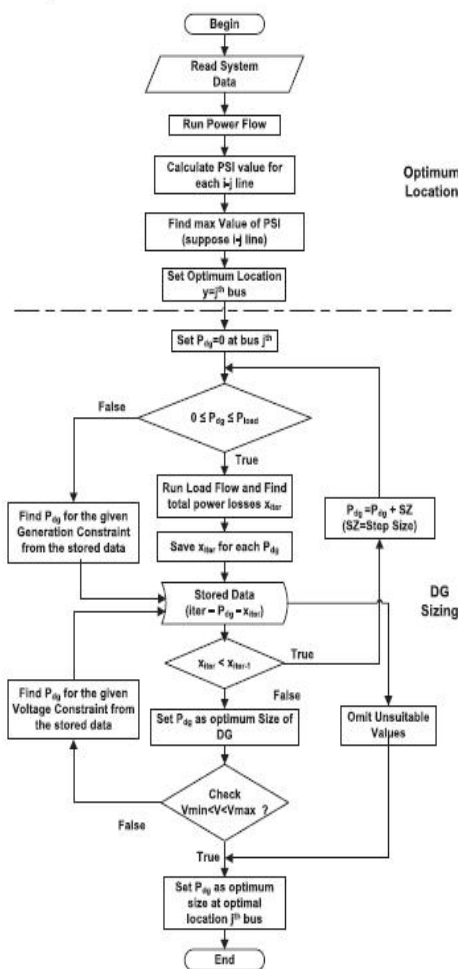

Figure.4: Flow chart of Proposed Algorithm.

4.SIMULATION AND RESULTS:

The proposed algorithm for DG placement and sizing is presented. For verification, the proposed algorithm is applied on 12-bus, modified 12-bus and 69-bus radial distribution networks. A computer program has been

written in MATLAB and run on Core 2 Duo 3.07 GHZ processor. Shirmohammadi theorem is used to carry out the load flow analysis. As conventional load flows are not suitable for radial distribution systems because they get diverges, due to high X/R ratio which results in singularity of Jacobian matrix.

4.1 Test systems:

The test system of 12-bus and 69-bus radial distribution test systems are shown in Figure 5a and 5b respectively. In modified 12-bus system, the active load on each bus is multiplied by 5 for better visualization of results, as the actual value of load is very small.

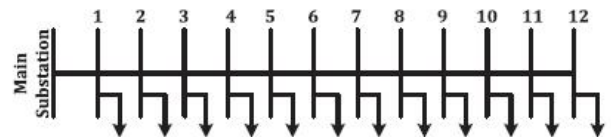

Figure.5a: Single line diagram of 12-bus radial network.

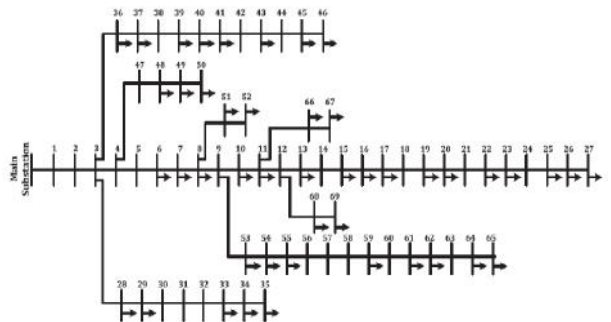

Figure.5b: Single line diagram of 69-bus radial network.

4.2 DG Placement based PSI:

The load flow analysis is carried out on 12-bus system and the PSI value is computed for each line using PSI equation, considering initially no DG. The PSI value for each line is shown in Figure. 6a. It could be observed that the 8th line connecting bus 8 and bus 9 have the highest value than the others. So the installation of DG at bus 9 will be the optimum place. The same approach is carried out for modified 12-bus and 69-bus test system; PSI graph for each system is shown Fig. 6b and c respectively. From Fig. 6b and c, it could be observed that the 8th and 60th line in modified 12-bus and 69-bus test system has the highest value of PSI respectively. Hence, the optimum location of DG is at bus 9 and bus 61 for 12-bus and 69-bus test systems respectively.

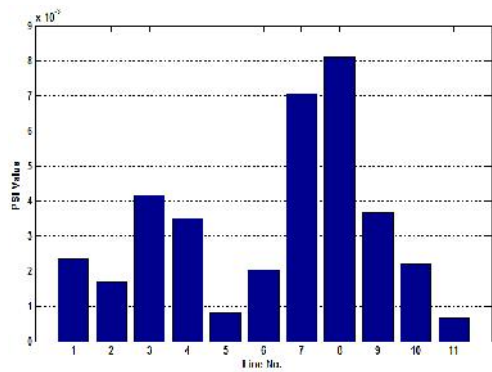

Fig 6a. PSI value for each line for 12-bus Radial Distribution System

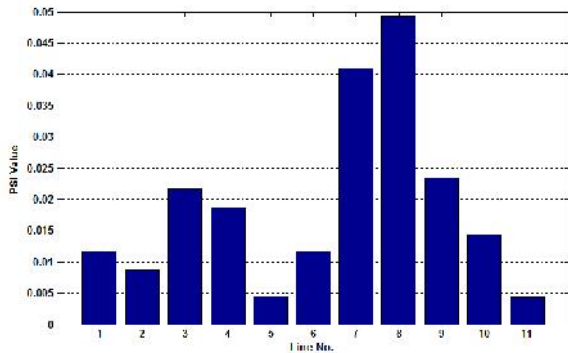

Fig. 6b PSI value for each line for modified 12-bus Radial Distribution System

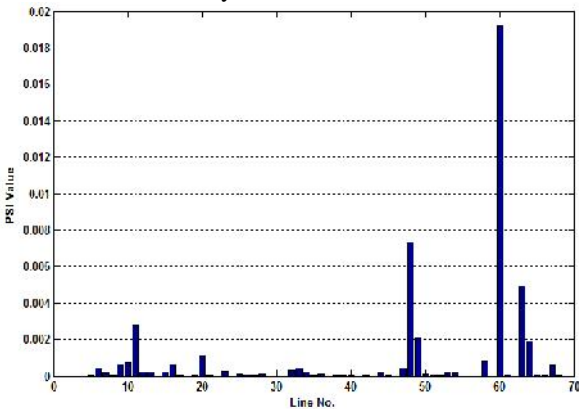

Fig. 6c PSI value for each line for 69-bus Radial Distribution System

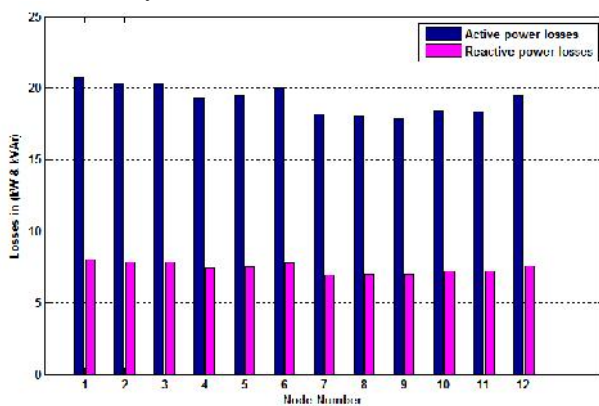

Fig. 7a: Effect of Q_G on system losses of 12-bus

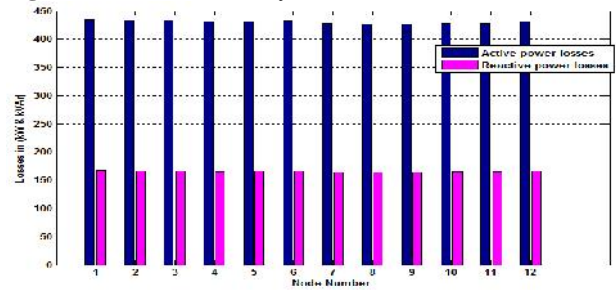

Fig 7b: Effect of Q_G on system losses of modified 12-bus system

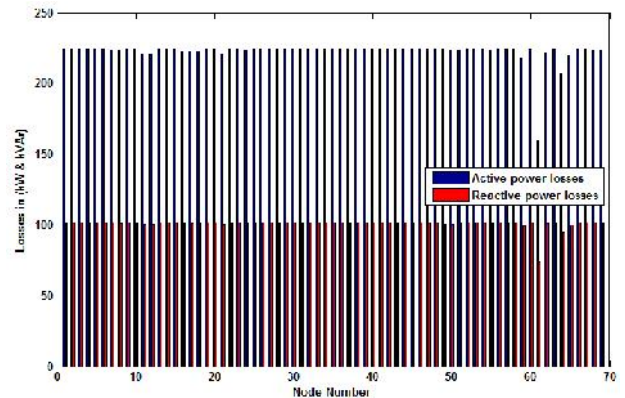

Fig. 7c Effect of Q_G on system losses of 69-bus system

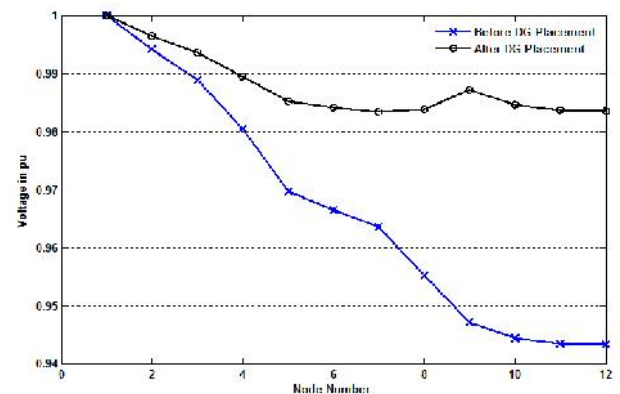

Fig 8a.Effect of DG on system voltage profile of 12-bus system (DG size = 0.2349 MW @ bus 9th)

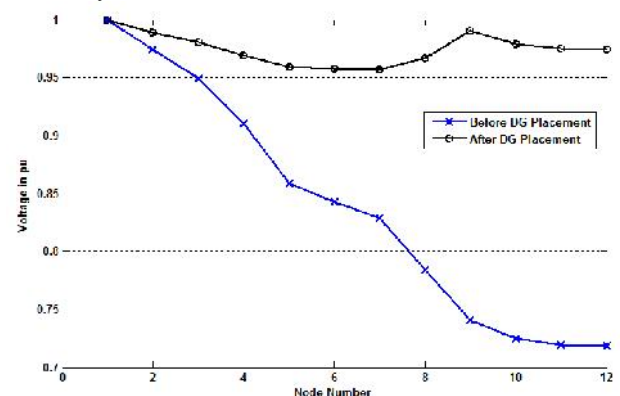

Fig. 8b Effect of DG on system voltage profile of modified 12-bus system (DG size = 1.1962 MW @ bus 9th)

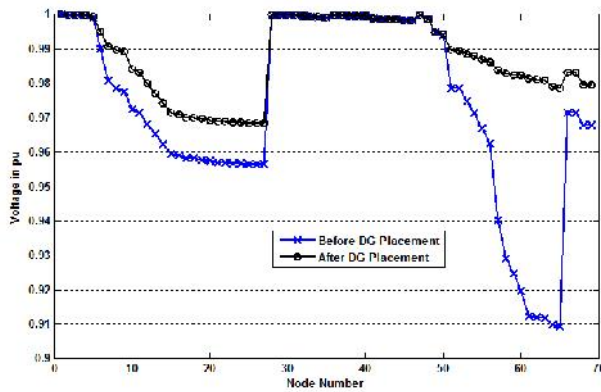

Fig. 8c :Effect of DG on system voltage profile of 69-bus system (DG size = 1.8580 MW @ bus 61st)

4.3 Overall Findings:

From the analysis of the simulation results presented in Section 4, we can conclude the following due to DG placement.

1. The voltage profile has improved
2. Line losses have reduced.
3. The overall system capacity has increased.

The most optimum location of each system and the nose curve (PV curve) is plotted for 12-bus, modified 12-bus and 69-bus systems respectively. The loading has been done at the 7th bus, 7th bus and 54th bus for 12-bus, modified 12-bus and 69-bus systems respectively. Figs. 9a, 9b and 9c demonstrate that the system capacity has increased due to the installation of DG at the best location and of optimum size.

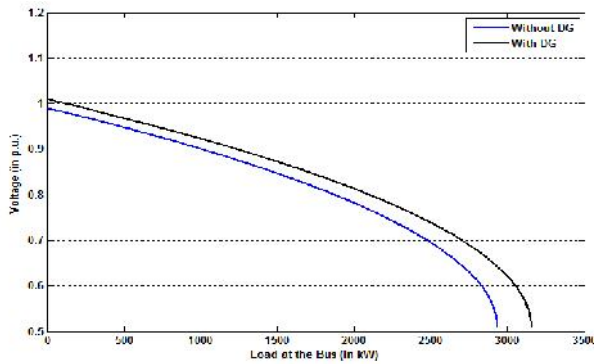

Fig. 9a PV characteristic curve with and without DG for 12-bus system (DG size = 0.2349 MW @ bus 9th)

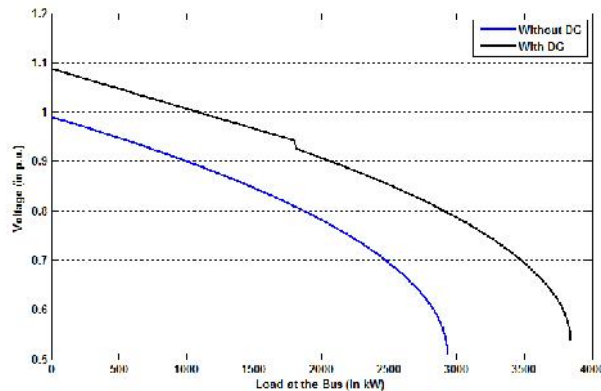

Fig. 9b:PV characteristic curve with and without DG for modified 12-bus system (DG size = 1.1962 MW @ bus 9th)

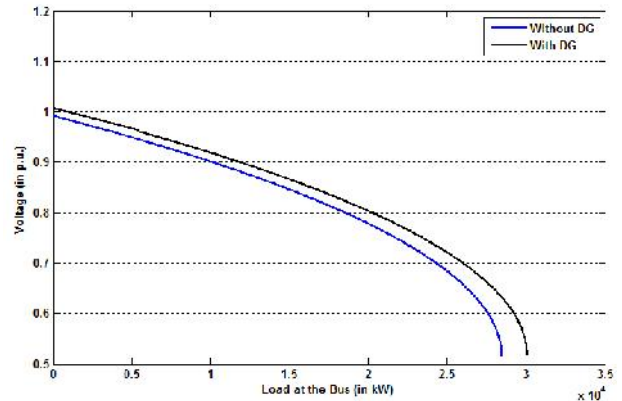

Fig. 9c :PV characteristic curve with and without DG for 69-bus system (DG size = 1.8580 MW @ bus 61st)

Bus System	Proposed Algorithm				Golden Section Search Algorithm		
	Max PSI Value	Bus No	Optimum Size, MW	CPU Time (s)	Bus No	Optimum Size, MW	CPU Time (s)
12-Bus	0.0081	9	0.2349	0.302	9	0.23545	0.892
12-Bus Modified	0.0494	9	1.1963	0.336	9	1.19119	0.897
69-Bus	0.0192	61	1.8580	9.047	61	1.87270	26.681

Table1: Application of proposed algorithm on radial distribution networks.

Bus System	Base Case			Proposed Algorithm		
	Minimum Voltage	Active Power Loss, kW	Reactive Power Loss, kVAr	Minimum Voltage	Active Power Loss, kW	Reactive Power Loss, kVAr
12-Bus	0.9434	20.71	8.04	0.9835	10.77	4.13
12-Bus Modified	0.7187	434.07	54.49	0.9573	166.82	19.28
69-Bus	0.9098	224.61	101.98	0.9683	82.88	40.40

Table2:Comparison of base case to proposed algorithm on radial distribution networks

From Tables 1 and 2, it could be observed that:

- The proposed method results are in close agreement with GSS algorithm
- The computation time has been decreased (53.6%, 52.39%, 58.45% respectively with the 12-bus, modified 12-bus and 69-bus).
- The minimum voltage is improved in all the test cases and also observed the system losses also reduced.

5.CONCLUSION:

A new algorithm is also proposed for DG location and sizing. The DG allocation and sizing is based on a novel Power Stability Index (PSI) index to determine the most volt-age sensitive bus and minimum total power losses. Using the pro-posed algorithm optimum DG allocation and correct sizing results in an improved voltage profile and minimizes the burden of system losses.

6. REFERENCES:

- [1] Jenkins N, Ekanayake J, Strbac G. Distributed generation – IET Factfiles; 2010. <http://www.theiet.org/factfiles/energy/distributed-generation.cfm> [accessed 10.08.11].
- [2] Energy Networks Association (UK). <<http://2010.energynetworks.org/distributed-generation>> [accessed 10.08.11].
- [3] Hadjsaid N, Canard JF, Dumas F. Dispersed generation impact on distribution networks. *IEEE ComputAppl Power* 1999;12:22–8.
- [4] Koepfel G. Distributed generation-literature review and outline of the Swiss station: Internal Report, ETH Zurich; November 2003
- [5] Tuitemwong K, Premrudeepreechacharn S. Expert system for protection coordination of distribution system with distributed generators. *Int J Electr Power* 2011;33:466–71.
- [6] Griffin T, Tomosovic K, Secrest D, Law A. Placement of dispersed generations systems for reduced losses. In: 33rd International conference on sciences. Hawaii; 2000.
- [7] Acharya N, Mahat P, Mithulananthan N. An analytical approach for DG allocation in primary distribution network. *Int J Electr Power*. 2006;28(10):669–78.
- [8] Caisheng W, Nehrir MH. Analytical approaches for optimal placement of distributed generation sources in power systems. *IEEE Trans Power Syst*. 2004;19(4):2068–76.
- [9] Gözel T, Hocaoglu MH. An analytical method for the sizing and siting of distributed generators in radial systems. *Electr Power Syst Res* 2009;79(6):912–8.
- [10] Ghosh S, Ghoshal SP, Ghosh SA. Optimal sizing and placement of distributed generation in a network system. *Int J Electr Power* 2010;32(8):849–56.
- [11] Lingfeng W, Singh C. Reliability-constrained optimum placement of reclosers and distributed generators in distribution networks using an ant colony system algorithm. *IEEE Trans Syst, Man Cyber, Part C: Appl Rev* 2008;38:757–64.
- [12] Kuersuk W, Ongsakul W. Optimal placement of distributed generation using particle swarm optimization. In: Australian universities power engineering conference (AUPEC' 06); 2006.
- [13] Moshtagh J, Jalali A, Karimizadeh K. Optimum placement and sizing of DG using binary PSO algorithm to achieve the minimum electricity cost for consumers. *Int Rev Electr Eng-I* 2010;5(6):2873–81.
- [14] Khalesi N, Rezaei N, Haghifam MR. DG allocation with application of dynamic programming for loss reduction and reliability improvement. *Int J Electr Power* 2011;33:288–95.
- [15] Borges CLT, Falcão DM. Optimal distributed generation allocation for reliability, losses, and voltage improvement. *Int J Electr Power* 2006;28(6):413–20.
- [16] Kim K-H, Lee Y-J, Rhee S-B, Lee S-K, You S-K. Dispersed generator placement using fuzzy-GA in distribution systems. In: Proceeding of IEEE power engineering society summer meeting. Chicago; July 2002. p. 1148–53.
- [17] Abou El-Ela AA, Allam SM, Shatla MM. Maximal optimal benefits of distributed generation using genetic algorithms. *Electr Power Syst Res* 2010;80:869–77.
- [18] Moradi MH, Abedini M. A combination of genetic algorithm and particle swarm optimization for optimal DG location and sizing in distribution systems. *Int J Electr Power Energy Syst* 2012;34:66–74.
- [19] Hedayati H, Nabaviniaki SA, Akbarimajd A. A method for placement of DG units in distribution networks. *IEEE Trans Power Deliver* 2008;23(3): 1620–8
- [20] Lalitha MP, Reddy VCV, Usha V. Optimal DG placement for minimum real power loss in radial distribution systems using PSO. *J Theor Appl Inform Technol* 2010;13:107–16



Mr.U.Krishna chaithanya was born in Andhra Pradesh, India. He received the B.Tech degree in Electrical and Electronics Engineering from N.B.K.R INSTITUTE OF SCIENCE AND TECHNOLOGY ,Vidyanagar in 2012 and pursuing M.Tech degree in Electical Power Systems from ASIT,Gudur,JTNU,Anantapur,AndhraPradesh, India His areas of interest in the field of power systems and electric Drives.**Email:**chaithu3243@gmail.com



Mr.M.Sreenivasulu was born in Andhra Pradesh, India. He received the B.Tech degree in Electrical and Electronics Engineering from Audisankara College of Engineering And Technology, Gudur, A.P. in 2010. After the completion of M.Tech degree in Computer Aided power systems from Vikrama Simhapuri University,Nellore in 2012, presently he is working as Asst.Professor Dept.EEE, Audisankara Institute of Technology-Gudur, Nellore, Andhrapradesh, India.His areas of interest in power systems and electrical mechines .**Email:** sreenivas280@gmail.com



Mr. Jan Bhasha Shaik was born in Andhra Pradesh, India. He received the B.Tech degree in Electrical and Electronics Engineering from JNT University, Hyderabad in 2004 and M.Tech degree in Power & Industrial Drives from JNT University Kakinada in 2010. He is currently pursuing the Ph.D. degree at the JNT University, Anantapur, Andhra Pradesh, India. He had worked as an Assistant Professor and IEEE student Branch counselor at Hi-Tech College of Engineering, and worked as an Assistant professor at KL University Guntur,AP. Currently He is working as an Associate Professor at Audisankara Institute of Technology, Gudur,AP. He was the academic project coordinator for for Under-Graduate & Post Graduate students. His areas of interest are HVDC, FACTS & SMART GRID .