

**A Simplified Space - Vector Pwm For Three Level Inverters Applied
To Passive And Motor Load****ABHINAV DUSARI**

P.G. scholar, Dept of EEE

Trr college of Engineering & Technology
Patancheru, Telangana, India**T BHARGAV RAM**

Associate professor

Trr college of Engineering & Technology
Patancheru, Telangana, India

ABSTRACT-Increase in renewable energy resources like solar , fuel cells had created a need for inverters which can work on higher operating voltages efficiently Advances in power electronics technology allowed the vide investigation of multilevel converters that provide high safety voltages ,less harmonic components ,utilization of more input voltage and flexibility in switching the legs compared to the two-level structures .and digital implementation is also very easy .In multilevel inverters space vector modulation (SVPWM) has become the most popular technique for three phase voltage source converters for the control of ac/dc drives and Flexible ac transmission application(FACT) controllers. In this paper a simplified SVPWM is being implemented . SVPWM for more than two levels is difficult because for them no. Of switching states is very high. In simplified SVPWM timing calculation is required for only one sector and therefore calculations are tremendously reduced and the same could be applied to different types of multilevel inverters like flying capacitor and cascaded h bridge. By using simplified SVPWM a passive RL load and motor load are being simulated in the MATLAB/SIMULINK.

I. INTRODUCTION

In the last two decades there has been considerable research emphasis on multilevel power converters as numerous industrial applications have begun to require higher power apparatus in recent years. Some medium voltage motor drives and utility applications require medium voltage and megawatt power level. For a medium voltage grid, it is troublesome to connect only one power semiconductor switch directly. As a result, a multilevel power converter structure has been introduced as an alternative in high power and medium voltage situations. A multilevel converter not only achieves high power ratings, but also enables the use of renewable energy sources.

Renewable energy sources such as photovoltaic, wind, and fuel cells can be easily

interfaced to a multilevel converter system for a high power application as in recent years, there has been great interest in multilevel inverter (MLI) technology including three-level neutral-clamped (NPC) voltage-source inverter (VSIs). [2] This type of inverters of producing five level line-to-line voltages. Therefore, with the same switching frequency, the harmonic content of the three level inverter output is less than that of the conventional two level inverter. In the three level inverter, required voltage rating of the devices is much lower and equal to half of the DC link voltage. This is the main advantage of the multi-level topology other than better spectral quality.

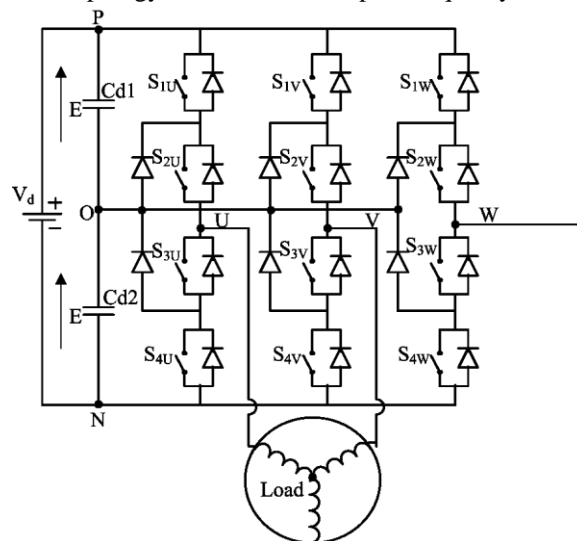

Fig.1. Schematic diagram of a three-level inverter connected to load

Thus, the three level inverter topology is widely used in heavy power industrial applications due to its high voltage handling and good harmonic rejection capabilities with the currently available power electronic devices.

Switching States	S1X	S2X	S3X	S4 X	VXO
P[1]	ON	ON	OFF	OFF	+E
O[0]	OFF	ON	ON	OFF	0
NL-11	OFF	OFF	ON	ON	-F

Other than high power/high voltage AC motor drives the three level topology is increasingly employed in flexible AC transmission (FACTS) System such as, SVC (Static Var Compensator), STATCOM (Static Compensator) etc. [3] To control multilevel inverters the pulse width modulation (PWM) strategies are the most effective, especially the space vector pulse width modulation (SVPWM) one, which has equally divided zero voltage vectors describing a lower harmonic distortion (THD) [4]. The space vector modulation technique is an advanced, computations intensive PWM technique and is possibly the best among all the PWM techniques for drive applications. Because of its superior performance characteristics, it is been finding wide spread application in recent years [5], [6]. In the technique given in [7], [8] twelve dwell time calculations for four regions of one sector and hence seventy two dwell time calculations of six sectors are required. In [9] not all the dwell times are required but still more computations required and the method is not simple. Here less computations required and stress been given to prove the application to motor load and hence validity of the method is not strongly proved [9]

In this paper, a simple SVPWM method for three-level inverter is proposed. By using this method out of six sectors and twenty four corresponding regions .Dwell time calculations for one sector i.e. of four regions is required and same be applied to other regions of remaining sectors just by rotating it by sixty degrees to get in other sector. And the same principal of the method can apply for other types of multilevel inverter like flying capacitor and Cascaded H Bridge. This technique is simulated for passive as well as motor load and open loop v/f speed control of induction motor is also done to enhance the validity of the scheme.

II. THREE LEVEL INVERTER

Fig. 1 shows a schematic diagram of a three-level neutral clamped inverter. Each phase of this inverter consists of two clamping diodes, four force commuted switches (IGBT). Table I shows the switching states of a three-level inverter. Since three kinds of switching states exist in each phase, a three-level inverter has 27(3³) switching states. Fig. 2

shows the representation of the space voltage vectors for a three-level inverter. There are 19 no. of space vectors out of which, Zero Vector V0 having magnitude is 0, Small Vectors (V1 to V6) having magnitude is $Vd/3$. Medium Vectors (V7 to V12) having magnitude is $\sqrt{3}Vd/3$. Large Vectors (V13 to V18) having magnitude is $2Vd/3$.

I. SECTOR DETERMINATION

For any given reference vector, we determine sector of operation and its angle within the sector by (1) and (2) respectively

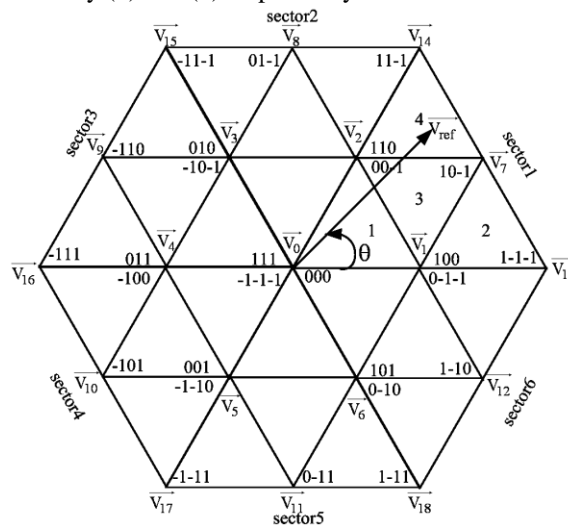

Fig. 2 Space voltage vectors with their switching states

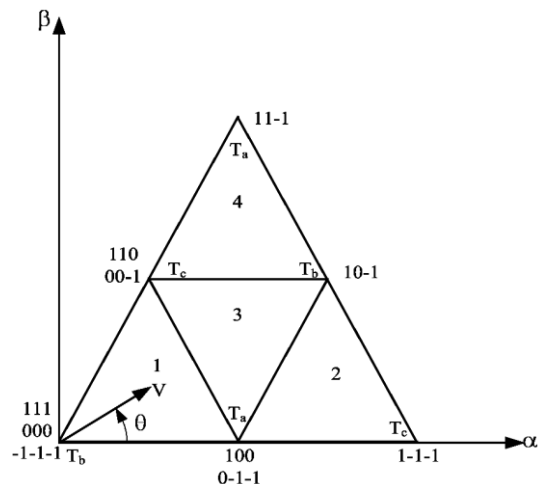

Fig.3.Sector 1 and its switching states for three-level inverter

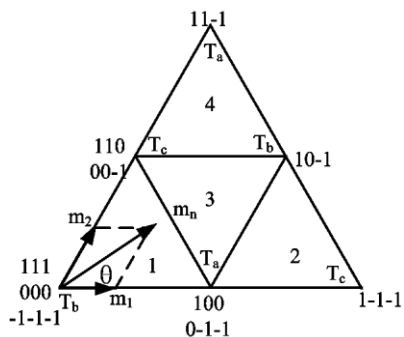

Fig.4. Sector 1(0°-60°) for calculation of m1 and m2

$$S_i = \text{int}\left(\frac{\theta}{60}\right) + 1 \quad (1)$$

$$\theta_i = \text{rem}\left(\frac{\theta}{60}\right) \quad (2)$$

where θ is the angle of the reference vector with respect to α axis, θ_i is the angle within the sector and S_i is its sector of operation as shown in Fig. 3.

II. SELECTION OF REGION

The calculations of lengths m_1 and m_2 are found out from (3) and (4) to get different conditions required for the location of reference vector in the region of the corresponding sector is as follows and explained in Fig. 4.

$$m_1 = m_n \left[\cos \theta - \sin \frac{\theta}{\sqrt{2}} \right] \quad (3)$$

$$m_2 = 2 m_n \sin \frac{\theta}{\sqrt{2}} \quad (4)$$

$$m_n = \sqrt{3} m_a$$

$$0 \leq m_a \leq 1$$

where $m_a = \text{modulation index} = \sqrt{3} \frac{v_{ref}}{v_d}$

Illustrations of location of reference vector in different regions with associated conditions in

Fig.5 (a) -Fig.5(d) (i) V_{ref} lies in region 1 if m_1, m_2 and $(m_1 + m_2) \leq 1$ (ii) V_{ref} lies in region 2 if $m_1 > 1$

(iii) V_{ref} lies in region 3 if $m_1 \leq 1, m_2 \leq 1$ and $(m_1 + m_2) > 1$ (iv) V_{ref} lies in region 4 if $m_2 > 1$.

I. DWELL TIME CALCULATIONS

The principle of SVPWM method is that the command voltage vector is approximately calculated by using three adjacent vectors. The duration of each voltage vectors obtained by vector calculations (5) and (6)

$$v_{ref} T_s = v_1 T_a + v_2 T_b + v_3 T_c \quad (5)$$

$$T_s = T_a + T_b + T_c \quad (6)$$

where V_1, V_2 and V_3 are vectors that define the triangle region in which is V_{ref} located. T_a, T_b and T_c are the corresponding vector durations and T_s is the sampling time. And is illustrated

I. SELECTION OF SWITCHING SEQUENCE AND CORRESPONDING STATES.

Seven segment switching are used and care is taken over of one switching transition i.e. only one device gets on or off. The switching orders for the four regions of sector 1 are as follows

- Region 1: -1-1-1, 0-1-1, 00-1, 000, 00-1, 0-1-1, -1-1-1
- Region 2: 0-1-1, 1-1-1, 10-1, 100, 10-1, 1-1-1, 0-1-1.
- Region 3: 0-1-1, 00-1, 10-1, 100, 10-1, 00-1, 0-1-1.
- Region 4: 00-1, 10-1, 11-1, 110, 11-1, 10-1, 00-1

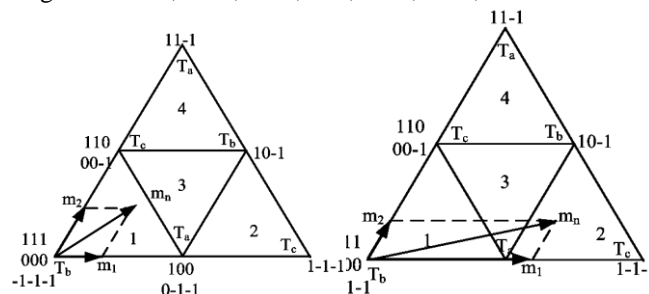

Fig.5 (a) Region 1 of sector 1 Fig. 5(b) Region 2 of sector 1

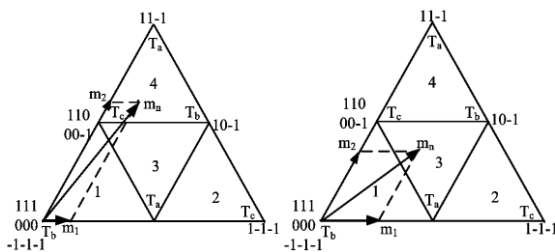

Fig.5(c) Region 3 of sector 1 Fig. 5 (d) Region 4 of sector 1

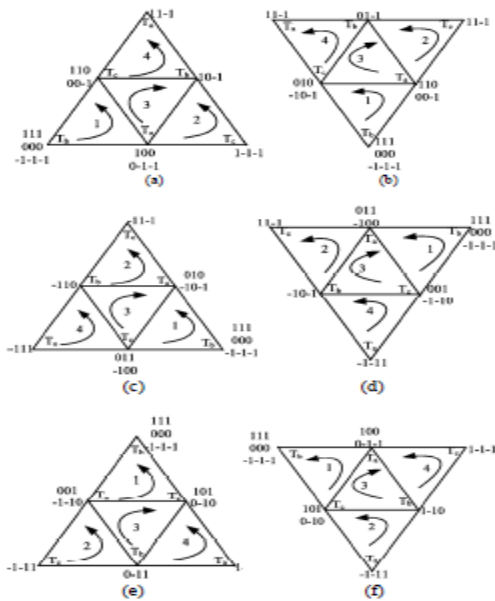

Fig.6. Switching sequence for three-level inverter: (a) for sector 1 (b) for sector 2 (c) for sector 3 (d) for sector 4 (e) for sector 5 (f) for sector 6

TABLE II
VECTOR DURATIONS OF VLTAGE VECTORS

Region	T_a	T_b	T_c
1	$T_s [2m_a \sin(\frac{\pi}{3} - \theta)]$	$T_s [1 - 2m_a \sin(\frac{\pi}{3} + \theta)]$	$T_s [2m_a \sin(\theta)]$
2	$T_s [2 - 2m_a \sin(\frac{\pi}{3} + \theta)]$	$T_s [2m_a \sin(\theta)]$	$T_s [2m_a \sin(\frac{\pi}{3} - \theta) - 1]$
3	$T_s [1 - 2m_a \sin(\theta)]$	$T_s [2m_a \sin(\frac{\pi}{3} + \theta) - 1]$	$T_s [1 - 2m_a \sin(\frac{\pi}{3} - \theta)]$
4	$T_s [2m_a \sin(\theta - 1)]$	$T_s [2m_a \sin(\frac{\pi}{3} - \theta)]$	$T_s [2 - 2m_a \sin(\frac{\pi}{3} + \theta)]$

In Fig. 6 (a)-(f) arrow direction indicates switching sequence to get only one transition in each regions of all i.e. of six sectors and the illustration of the switching pattern for four regions of sector 1 as per above switching conditions are explained in Fig. 7 (a) - (d)

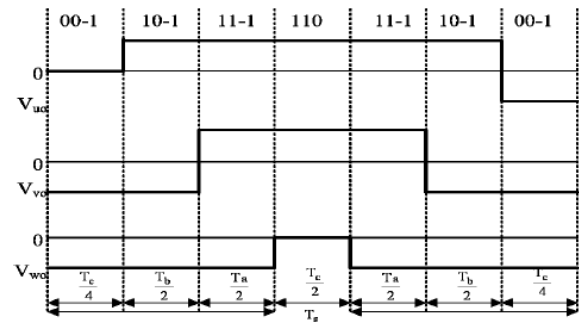

Fig 7 (a)

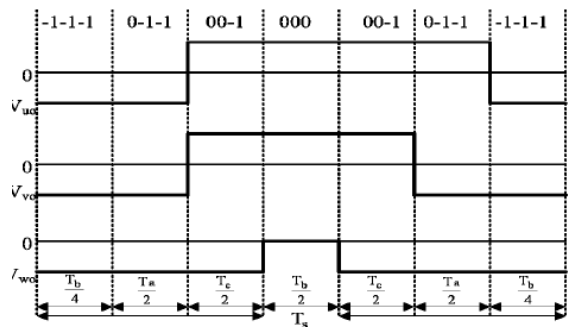

Fig 7 (b)

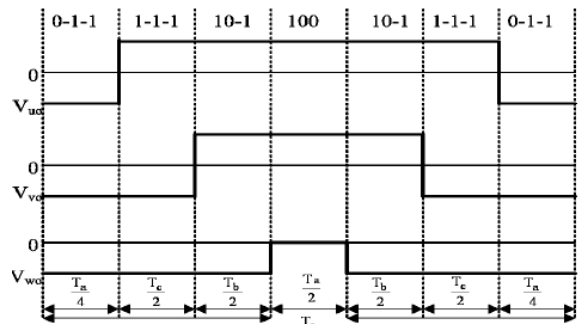

Fig 7 (c)

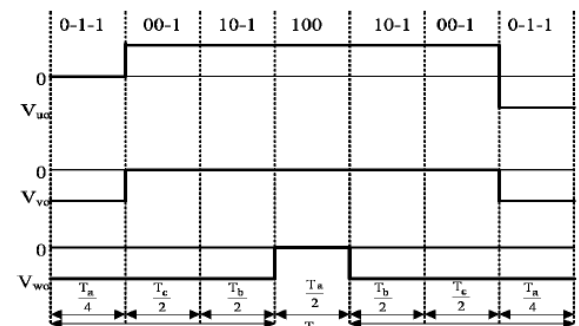

Fig 7(d)

Fig. 7 . switching pattern for sector1 (a) region 1 (b) region 2 (c) region 3 (d) region 4.

II. SOFTWARE IMPLEMENTATION

Fig.7. - Fig.10. are the illustration of implementation in SIMULINK/ MATLAB Program, in which modulation index, sector determination, calculation of m1 and m2, timing calculations of sector1 and timing patterns are given.

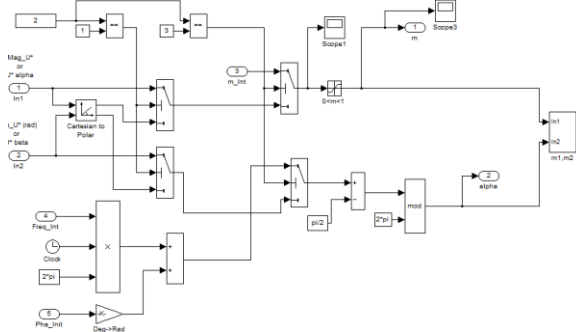

Figure.7 Determination of modulation index (m) and theta

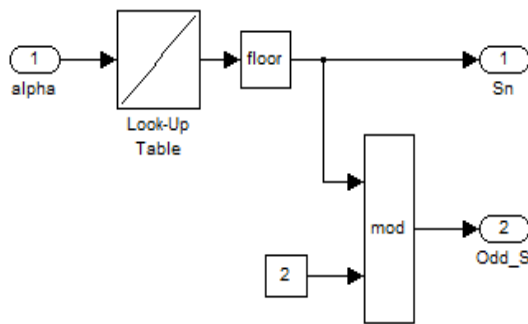

Figure.8 Finding out Sector for revolving Reference Vector in space and also angle of revolution theta1

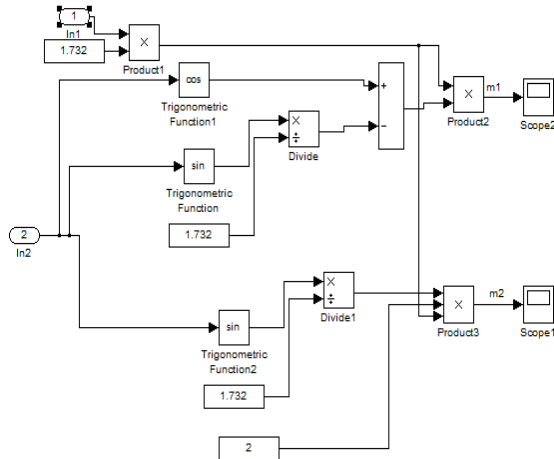

Figure.9 Determination of m1 and m2

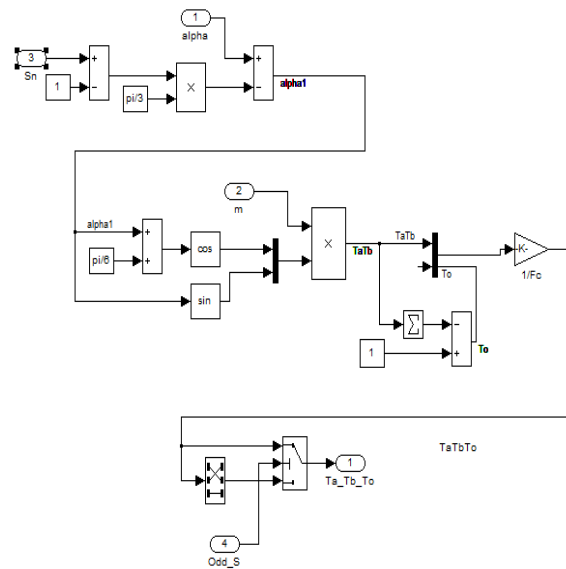

Figure.10 Determination of Ta, Tb, Tc for Region 1.

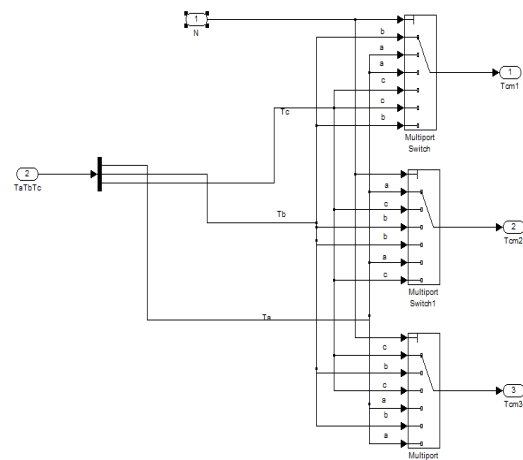

Figure.11 finding out the switching pattern for region 1
SIMULINK/ MATLAB circuit connected to a passive load

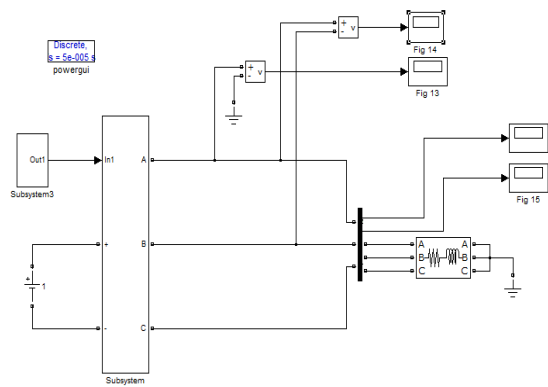

Fig 12 shows SVPWM inverter connected to a passive load

SIMULINK/ MATLAB circuit connected to a motor load

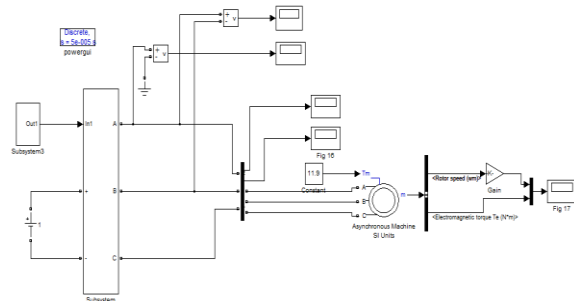

Fig 13 shows the SVPWM inverter connected to a motor load

III. SIMULATION RESULTS

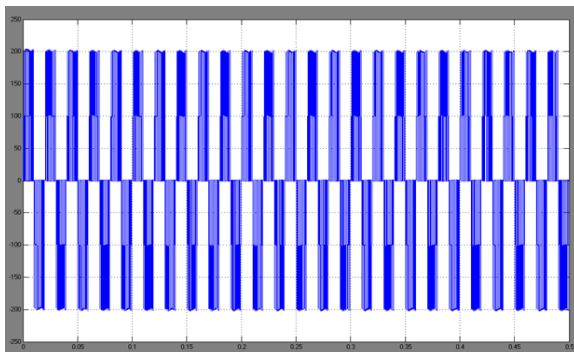

Figure.14 Line to neutral voltage at $m=0.8$, $f_{sw}=1$ kHz

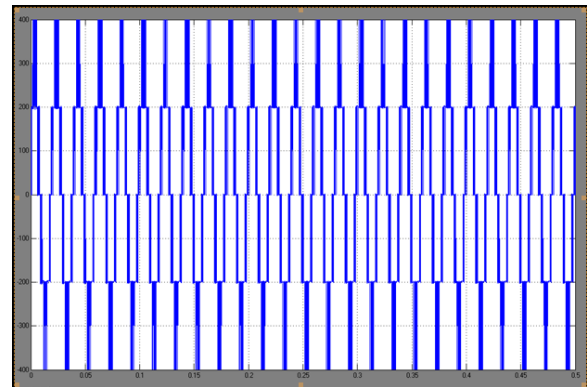

Figure.15
Line to line voltage at $m=0.8$, $f_{sw}=1$ kHz

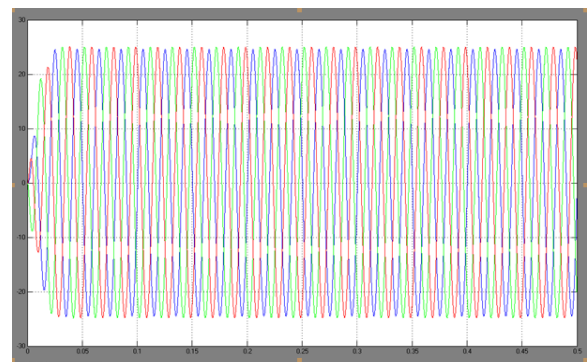

Fig.16. Three phase line currents for $f=50$ Hz
Three phase line currents

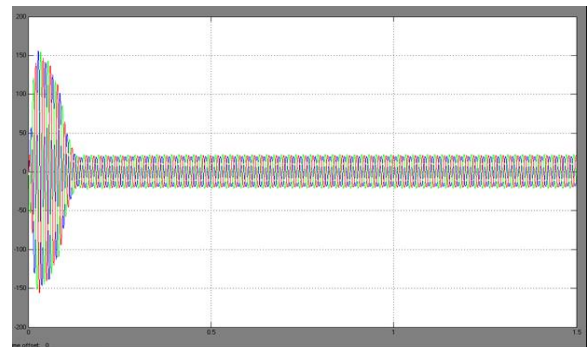

Figure.17 Three phase Stator current at no load

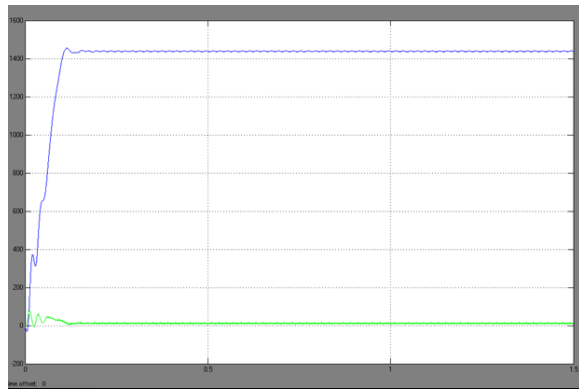

Figure.18 Speed (RPM) and Torque (N-m)

Characteristics at no load

Simulation results have been taken for various operating conditions feeding passive load, induction motor. Result have been taken for passive load of $R=15$ ohms and $L=4.6$ H. Switching frequency of 1 kHz was used in the model. DC link voltage of the neutral point clamped (NPC) inverter was taken as 400V.

Simulation Results shown in Figure 14 to Figure 16 have been obtained for modulation index of 0.8 and output frequency of 50Hz. Figure 14 illustrate output phase voltage (V_{an}) and Figure 14 illustrate output line voltage of inverter (V_{ab}) which is applied to an R-L load. As can be seen from Figure 15 output waveform is of five levels. Corresponding three phase line currents are shown in Figure 15. Although 1 kHz of switching frequency is used, the current waveforms have sinusoidal shape. This is one of the most important advantages of multilevel inverter.

Simulation has been repeated for an induction motor load. Figure 17 shows three phase motor currents fed by three level inverter at 50 Hz output frequency. Modulation index is taken as 0.82 considering constant V/f steady state operation. The result shown in Figure 16 and 17 have been taken at no-load condition. Figure 17 illustrate speed and torque characteristics of motor at no load. From this, it is observed that motor starts from zero speed come to the constant speed of 1500 rpm. Figure 16 gives the stator current waveform during starting and running condition at no load.

Appendix:

1) R-L Load.
 $R=15$ ohms.
 $L=4.6$ H.
 $V_{dc}=400$ V.
 $f=50$ Hz.

$f_{sw}=1$ kHz.

2) Induction Motor Load. Ratings of three phase , 4pole, 400V, 50 Hz squirrel cage induction motor are:

Frequency:50 Hz

Stator Resistance (R_s): 0.7384 ohms.

Rotor Resistance (R_r): 0.7402 ohms.

Stator Leakage Inductance (Ls): 0.003045 H.

Rotor Leakage Inductance (L_{lr}): 0.003045 H.

Magnetizing Inductance (L_m): 0.2141 H

Rotor Inertia: 0.0143 Kg m^2

P_n : 10 HP

T_m :11.9 N-m

IV. CONCLUSION

In this paper effort is done to simplify the space vector PWM method for multi-level inverter. And to prove the validity .The method is checked for passive as well as motor load. With this method higher utilization of input voltage, reduced THD , and reduction in stress on the operating switch is being obtained .reduction in current ripples and reduction in distortion of voltages is obtained from the simulation model in MATLAB /SIMULINK environment .Another advantage of this method is that it can be applied for any level or different types of multi-level inverter like flying-capacitor, cascaded and hybrid multi-level inverter. From the simulated results we can say that SVPWM is best suited for motor drive applications

REFERENCES

- [1] G. Carrara, S. Gardella, M. Marchesoni, R. Salutari and G. Scintto, "ANew multilevel PWM method: A theoretical analysis," IEEE Trans.Power Electron. vol.7, July 1992 pp. 497-505.
- [2] A. Nabbae, I.Takashi, and H. Akagi, "A New neutral-point clampedPWM inverter," IEEE Trans. Ind. Applicat, vol. 7, Sept./Oct. 1981 pp.518-523.
- [3] K. R. M. N. Rataynake, Y. Murali, T. Watanbe, "Novel PWM scheme tocontrol neutral point voltage variation in three-level voltage source inverter," IEEE Industry Applications Conference,Record., 34thIASAnnual Meeting ,1999,vol.3,3-7 Oct.1999 pp19501955 .
- [4] Y-H Lee, D-H Kim, D-S Hyun, "Carrier-Based SVPWM method formulti-level system with reduced HDF", IEEE Conference on IndustryApplications. Conference Record vol.3, 8-12 October 2000, pp.866-868.

- [5] J.-H. Youm and B. -H. Kwon, "An effective software implementation of the space-vector modulation," IEEE Trans. Ind. Electron., vol.46, Aug. 1999, pp. 866-868.
- [6] Zhou and D. Wang, "Relationship between spacevector modulation and three-phase carrier-based PWM: A comprehensive analysis," IEEE Trans. Ind. Electron., vol. 49, Feb. 2002 pp. 186-196.
- [7] P. F. Seixas, M. A. Servw Mendes, P. Donos Garcia' "An algebraic PWM method for three-level voltage source inverter," IEEE Conference on Industry Applications, 2000, Conference Record, vol.4, 8-12 October 2000, pp. 2177-2184.
- [8] P. Purkait and R. S. Sriranakavachaam, "A new generalized space vector modulation algorithm for neutral-point-clamped multi-level converters," In the Progress In Electromagnetic Research Symposium 2006, Cambridge, USA, March 26-29, 2006.
- [9] Ayse Kocalms, and Sedat Sunter, "Simulation of a space vector PWM controller for three-level voltage-fed inverter motor drive," IEEE Conference on Industrial Electronics 2006, IECON 2006-32 Annual Conference Record , 6-10 Nov. 2006, pp. 1915-1920.
- [10] M.M. Renge and H. M. Suryawanshi, "Five level diode clamped inverter to eliminate common mode voltage and reduce dv/dt in medium voltage rating induction motor drives," IEEE Trans. Power Electron., July 2008, vol. 23, no. 4, pp. 1598-1607.

ABHINAV DUSARI currently pursuing his M.Tech in Electrical Power Systems from TRR Engineering College, Hyderabad, Telangana, India affiliated to JNTU University, Hyderabad. He has done his B.Tech degree from Ellenki Engineering College, affiliated to JNT University, Hyderabad, Telangana, India and his fields of interest include Non Conventional Energy Sources, power electronics and Power Systems.

BHARGAV RAM T working as Associate Professor in TRR Engineering College, Hyderabad, Telangana, India affiliated to JNTU University, Hyderabad with 12 years of experience in teaching and various fields. His fields of interest include Non Conventional Energy Sources, power electronics and Power Systems.