

Design and Construction of a Motorized Citrus Juice Extractor

*¹Oluwaseun O. Martins, ²Bukola O. Bolaji, ³Oluwole H. Adeyemi and ²Olawale M. Sanusi

¹Department of Mechatronics Engineering, Federal University, Oye-Ekiti, Nigeria

²Department of Mechanical Engineering, Federal University, Oye-Ekiti, Nigeria

³Department of Mechanical Engineering, Olabisi Onabanjo University, Ago-Iwoye, Nigeria
{oluwaseun.martins | bukola.bolaji | olawalem.sanusi@fuoye.edu.ng} | ahacoy@yahoo.com

Abstract— This paper presents the design, construction and performance evaluation of a locally fabricated motorized citrus juice extractor for small and medium scale industry. The fabrication materials for the machine comprises of stainless steel aluminum alloy which is used for the construction of the hopper, compression chamber and collector or receiver. The presser and perforated cylindrical sieve was formed using stainless steel sheet. The power shaft was machined from stainless steel solid shaft; mild steel angle bar was used for the main frame while the transmission pulleys were machined from mild steel material. In selection of materials for the machine critical properties such as toxicity, corrosion and pitting resistance were considered. For power transmission, 4 HP electric motor, V-belt and cast iron ball bearings were used. The performance evaluation of the machine shows that the machine extraction capacity and extraction efficiency are significantly affected by the prime mover speed in revolution per minutes (rpm). The machine efficiency is found to be 84.54 %, average juice extraction capacity is 10.92 cm³/sec or 39.312 lit/h at 600 rpm and the machine capacity is 38.89 kg/h. The production cost of the machine is about ₦ 117,800.00 (326 USD) this cost compared with the imported GG-0.5 model of similar capacity which cost about 3150 USD makes the machine considerably acquirable for use by both small and medium scale citrus juice processing plants in Nigeria.

Keywords— Design, Extraction efficiency, Fabrication, Juice extractor, Performance evaluation.

1 INTRODUCTION

Oranges, lemon, limes, grape fruits and tangerines are member of the class of fruit known as citrus fruits (Olife et al., 2015). It is universally acknowledged that citrus fruits emanated from north eastern India (Ortese et al., (2012). The Federal Department of Agriculture and Missionaries in the 1930s introduced citrus fruit to Nigeria. Since its introduction the cultivation of citrus fruit has spread to every part of the country and recently ranked as the most extensively cultivated fruit tree in the country particularly in South-Western Nigeria (Oyedede & Yahaya, 2010).

With regard to international trade, citrus fruits are ranked highest worth fruit crop. The market available for citrus fruits is the fresh fruit market and the processed citrus fruits market chiefly orange juice (Olife et al., 2015). Orange (citrus sinensis: sweet orange) accounts for the most produced citrus fruit with a global production forecast for 2016/2017 at 2.4 million metric tons and the global production forecast for orange juice for 2016/2017 at 2.0 million metric tons (USDA, 2017).

Citrus (oranges) and citrus products contain very high nutritional contents; they are rich and cheap sources of vitamins (particularly vitamin C), minerals and dietary fibre which are essential for healthy living. In 2007 Nigeria was ranked the 9th in the world citrus production; producing about 3,325,000 tons (Oyedede & Yahaya, 2010). Orange (hesperidia) is a specialized type of berry and the structure consists of a soft, pithy central axis surrounded by 10-15 segments which contains the pulp and juice. The segment is enveloped in the oily rind leathery which poses a white spongy inner part and a harder, orange coloured outer part that contains many glands which secrete oil. Contained in the segment juice are sugar, organic acid (mainly citric acid) and several other components that give the orange it unique taste. Orange is a rich source of vitamins A, B and C (Sylvester & Abugh, 2012).

Dhineshkumar & Siddharth (2015) conducted a study on the physical properties (dimensions, mass, volume, surface area, porosity and coefficient of static friction) of oranges using 100 randomly selected samples. The result revealed that the average mass is 165.13 g. Similarly, Sharifi et al., (2007) carried out an experiment on the physical properties of oranges using 150 randomly selected samples and found that the average mass is 168.19 g. Oranges like most other tropical fruit are seasonal and as such they are not available all year round and in addition, they are highly perishable especially in the Sub-Saharan region (Olaniyan, 2010). Ndubisi et al., (2013) conducted a study on the postharvest losses of fruits and the result showed a loss of about 30 % within raining season which accounts for scarcity and high cost of fresh fruits during off-season.

The high temperature and low relative humidity in the tropics causes oranges to respire quickly after harvest, thereby losing moisture via transpiration. The resulting hastened biochemical reaction causes the oranges to deteriorate rapidly. The shelf life of oranges in its natural form is within 2-10 days. This shelf-life can be improved upon if the fruit is stored in a controlled atmosphere or processes into more stable products for example juice, drinks, jellies and jam (Oluwalana, 2006). Refrigeration, hypobaric storage, packaging in plastic films, use of food surface coatings, chemical treatments and irradiation are some of the methods for prolonging the storage life of fruits. However, these methods are expensive in Nigeria and in other developing countries as market value of the fruits will not be sufficient to offset cost of such methods.

The most practicable method of prolonging the storage life of fruits is the extraction of the fluid content which can then be processed into juice, jam and jelly (Abulude et al., 2007; Oluwalana, 2006). Depending on the method of preservation and packaging, fruit juices are capable of spending months even years before they expire (Abulude et al., 2007). Fruit juice can be defined as the extraction of cells or tissues fluid content of the fruit or the extraction of the unfermented but fermentable fluid

* Corresponding Author

for the purpose of human consumption, through mechanical process from wholesome fully developed fruit (Oluwalana, 2006).

It is said that juice production from fruits has been in existence for years (Bates et al., 2001). Fully developed fruit are usually soft to the extent that mere manipulation or while in transit they produce juice. The juice is often more tasteful than the solid part of the fruits. The effective and applicable means of extracting juice from the source fruits were achieved by man after several attempts. The extraction of juice from source fruits was enhanced by the manufacture of juice extraction devices. The means of extracting juice from fruits are the Brown method and the In-Line method. The Brown method requires the fruit to be cut in half and the juice extracted by the action of a reamer while the In-Line method uses a specially designed machine for the extraction of juice from the fruits.

Abulude et al., (2007) listed the following as the process involved in the extraction of juice from fruit; sorting, washing, pressing, slicing, crushing and extraction, addition of additives, homogenization, pasteurization (heat treatment), packaging and storage. The primitive process of juice extraction includes crushing and pulping with mortar and pestle or blender and then sieving via muslin cloth or plastic sieve. The major demerit of this procedure is low extracted volume and low efficiency. Hence, the development of orange juice extractor from locally sourced materials at minimal cost to effectively and efficiently extract orange juice will improve the availability of orange juice at affordable price, increase its consumption and also reduce its postharvest losses. Adejuyigbe & Bolaji (2005); Bolaji et al., (2008); Adejuyigbe & Bolaji (2012) have reported that one of the ways to improve agricultural mechanization in Nigeria is the encouragement of indigenous design, development and manufacture of most of the required machines and equipment, this is to ensure their compatibility and sustainability for the farm produce as well as the incorporation of farmers technical and financial consideration.

It is worthy to note that several research has been conducted locally in this area, some are manually operated (Aremu & Ogunlade, 2016); (Oguntuyi, 2013) and (Abulude et al., 2007) while some are motorized (Olabisi & Adelegan, 2015) and (Olaniyan, 2010). This present work is aimed at designing a motorized citrus juice extractor that will be acquirable for use by both small and medium scale citrus juice processing plants in Nigeria at a preferred cost compared to an imported extractor of similar capacity. As well as improving the machine capacity of the motorized juice extractor. Therefore, this paper presents the design, construction and performance evaluation of a locally fabricated motorized citrus (orange) juice extractor for small and medium scale citrus juice processing plants in Nigeria.

2 DESIGN AND FABRICATION

The components of the designed orange juice extractor are as follows: the hopper, electric motor, pulleys,

bearings, drive belt, collector, shaft, bolts, machine frame and compression chamber which houses the presser of reamers, perforated cylindrical sieve which sieves the pulp, seeds and skin.

The process of juice extraction with the present design starts from the preparation of the orange fruit (washing, peeling and cutting into half), loading of the half oranges into the hopper which channels the oranges to the compression chamber. In the compression chamber the presser compresses the half oranges against the perforated cylindrical sieve and the separated juice is collected at the collector unit. The hull of fruits is ejected from the incorporated outlet.

Hopper Design: The hopper design was based on the composite volume which is segmented into three rectangles and two triangular prisms. The volume of a rectangle and triangular prism is established as follows (Earl, 2015):

Volume of a rectangle = lwh

Volume of triangular prism = $\frac{bhl}{2}$

Therefore, the volume of the hopper is:

$$V_h = 3(lwh) + 2\left(\frac{bhl}{2}\right) \quad (1)$$

Where:

l = length of the rectangle or triangular prism as it applies

b = base of the triangular prism

h = height of the rectangle or triangular prism as it applies

w = width of the rectangle

Volume of Orange: The volume of orange (V_0) is treated as a sphere. The volume of orange is established as follows (Earl, 2015):

$$V_0 = \frac{4\pi r_0^3}{3} \quad (2)$$

Where:

r = radius of the orange

π = constant taken as 3.1428

Batch Size (B_s): The batch size is established as the quantity of oranges that will fill the hopper to capacity. Therefore, the batch size is obtained as:

$$\text{Quantity of oranges per batch} = \frac{V_h}{V_0} \quad (3)$$

Compression Chamber Design: The analogy of thin-walled-cylindrical pressure vessel is applied to compression chamber (Ahmed et al., 2015), the longitudinal stress acting in the cylinder is:

$$\sigma = \frac{Pr_{cc}}{2t} \quad (4)$$

Where:

σ = longitudinal stress

P = internal pressure

r_{cc} = internal radius of the compression chamber

t = thickness of the compression chamber

Volume of the Compression Chamber (V_{cc}): The compression chamber volume is treated as a cylinder. The volume of the compression chamber is established as (Earl, 2015):

$$V_{cc} = \pi r_{cc}^2 l_{cc} \quad (5)$$

Where:

r_{cc} = internal radius of the compression chamber

l_{cc} = length of compression chamber

Volume of the Presser Reamer in the Compression Chamber (V_{pr}):

$$V_{pr} = \pi r_{pr}^2 l_{pr} \quad (6)$$

Where:

r_{pr} = radius of the presser reamer

l_{pr} = length of presser reamer

Speed Ratio (i_{da}) Between Two Pulleys: The speed ratio between the two pulleys (driver and the driven) is presented as follows (Joseph & Charles, 1996):

$$i_{da} = \frac{N_1}{N_2} = \frac{d_2}{d_1} \quad (7)$$

Where:

N_1 = speed of the small pulley

N_2 = speed of the large pulley

d_1 = diameter of the small pulley

d_2 = diameter of the large pulley

Centre Distance (e) Between the Driver and the Driven Pulleys: The centre distance between the driving and the driven pulley is established as follows (Joseph & Charles, 1996):

$$e = \frac{k + \sqrt{k^2 - 32(D-d)^2}}{16} \quad (8)$$

$$k = 4l - 2\pi(D - d)$$

Where:

e = centre distance between the driving and the driven pulley

D = diameter of the large pulley

d = diameter of the small pulley

l = length of the belt

Belt Length (L): The belt length is obtained as follows (Joseph & Charles, 1996):

$$L = 2e + 1.57d_1(i_{da} + 1) + \frac{d_1^2(i_{da}-1)}{4} \quad (9)$$

Where:

L = center distance between the driving and the driven pulley

d_1 = diameter of the small pulley

i_{da} = speed ratio between the two pulleys

L = length of the belt

Power required to drive the Shaft: The power (P) required to drive the shaft is expressed as (Adejuyigbe & Bolaji, 2012):

$$P = T_s \omega_s \quad (10)$$

$$\omega_s = 2\pi N_s$$

T_s = torque on the shaft

ω_s = angular speed of shaft

N_s = shaft revolution per minutes

Shaft Diameter: The diameter of the shaft is given by (Shigley & Mitchell, 1983):

$$d^3 = \frac{16T}{0.27\pi\delta_0} \quad (11)$$

Where:

d is the shaft diameter in m

T_s is the maximum torque in Nm

δ_0 is the yield stress in N/m²

π is a constant

2.1 DESIGN DESCRIPTION AND MATERIAL SELECTION DETAILS

The orange juice extractor machine is electrically powered and the drive is achieved by an electric motor via belt transmission. The components of the orange juice extractor may be broadly classified into the hopper, compression unit, power unit and the machine frame.

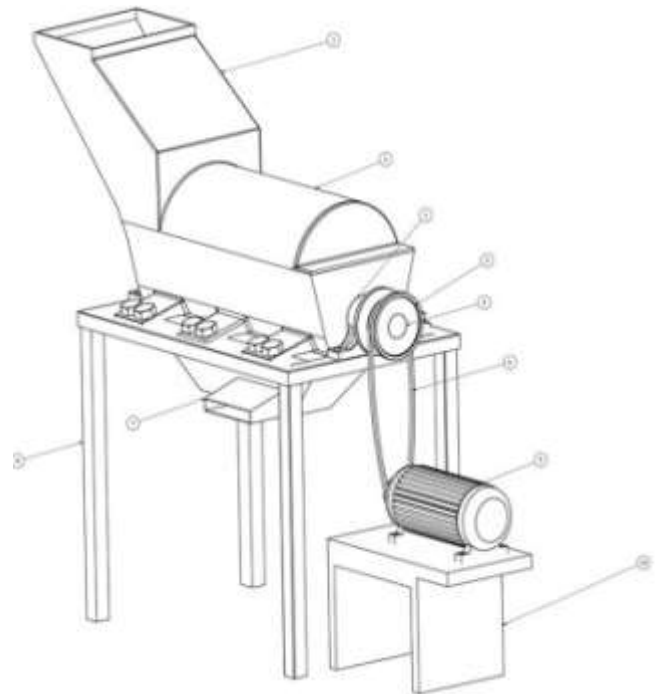

Fig. 1: Isometric view of Orange Juice Extraction Machine (1)Hopper unit, (2) Compression unit, (3) Bearing, (4) Power shaft, (5) Pulley, (6) Belt, (7) Collector unit, (8) Machine frame, (9) Prime mover, (10) Prime mover base plate

Hopper unit: The machine is loaded with the half oranges via this unit (shown in Fig. 1) and channels the oranges to the compression unit. It is fabricated with galvanized steel due to its non-toxic properties, good corrosion resistance and does not discolour food.

Compression unit: The compression unit comprises of the power shaft, bearings, compression chamber and collector.

Power shaft: The power shaft is a cylindrical shape stainless steel with uniform diameter of 32 mm solid shaft. The two ends are press fitted through the bore of the ball bearings to support load and secure the shaft.

Bearings: Two deep groove 32 mm ball bearings encased in a rigid housing. The bearings support the power shaft at both ends of the compression unit. The bearings are secured to the machine frame with M12 bolt and nut.

Compression chamber: The compression chamber is fabricated with stainless steel aluminum alloy owing to its non-toxic properties, good corrosion resistance, resistance to pitting and does not discolour food. It comprises of the presser of reamers and perforated cylindrical sieve.

Presser and perforated cylindrical sieve: The presser and perforated cylindrical sieve are fabricated from stainless steel for high strength and rigidity, resistance to pitting, corrosion resistance and ease of machining.

Collector or receiver: The extracted juice is collected at the collector. It is fabricated with stainless steel aluminum alloy because of its non-toxic properties and good corrosion resistance.

Power unit: The unit comprises of a 3 kw 1200 rpm single phase electric motor, single V-belt and pulleys of 105 mm and 200 mm diameter; this transmits power from the electric motor to the power shaft. The pulleys are machined from mild steel material.

Machine frame: The components of the machine are supported by the machine frame. It is fabricated from mild steel angle bar. The machine frame also provides the stand for the machine.

2.2 OPERATION OF THE MACHINE

The machine is operated by a single operator due to its ease of operation. Prior to the operation of the machine the operator should ensure that all parts are well set, fixed and bolted appropriately. The oranges are peeled and cut into two halves and these half oranges are loaded into the hopper. The prime mover transmits power to the shaft and presser in the compression chamber. The half oranges travel radially along the presser. The presser presses the half oranges against the perforated cylindrical sieve and the separated juice is collected at the collector unit. The hull of fruits is ejected from the incorporated outlet.

2.3 MAINTENANCE

The maintenance of the machine is imperative in order to ensure the smooth-running and durability of the machine. Therefore, the following stated preventive maintenance tips and precautions should be followed. Clean both the inner and outer part of the machine before and after use as well as the regular lubrication of the ball bearings through the grease nipple provided. Confirm that all bolt and nut is well tightened chiefly the ones securing the compression chamber and the collector unit to prevent vibration and leakage. The machine hopper should not be loaded above recommended capacity in order not to hamper the operation in the compression unit. In addition, the belt should be well tensioned and secured on the pulleys. The hopper

should be covered when the machine is not in operation to prevent access to foreign materials.

3 RESULTS AND DISCUSSION

The performance of the machine was evaluated after 5 runs of batch size of 32 peeled oranges per run. In order to establish the average mass per peeled oranges, 32 peeled oranges were selected at random and the mass of each was taken using the weighing balance.

The total mass of the randomly selected 32 peeled oranges was 5144.6 g which gives an average of 160.77 g per peeled orange. The machine was loaded with 32 peeled oranges cut into half per batch for each of the 5 runs. The volume and the mass of the extracted juice by the machine were taken using the graduated beaker and weighing balance respectively. The table below presents the result of the conducted test.

Table 1. Extraction volume and juice extraction capacity for different runs

Run	Batch size	Extracted juice volume per batch (cm ³)	Mass of extracted juice per batch (g)	Extraction time (sec)	Mass rate (g/sec)	Juice extraction capacity (cm ³ /sec)
1 th	32	2368	2350	210	11.19	11.28
2 nd	32	2394	2365	218	10.84	10.98
3 rd	32	2362	2344	208	11.27	11.36
4 th	32	2403	2371	239	9.92	10.06
5 th	32	2382	2354	218	10.79	10.93
Total	160	11909	11784	1093	54.01	54.61

Table 2 Mass of peeled oranges, mass of extracted juice and juice yield for different runs

Run	Batch size	Mass of peeled oranges per batch (g)	Mass of extracted juice per batch (g)	Mass of rejected pulp, seed and skin per batch (g)	Juice yield (%)
1 th	32	5144.6	2350	2794.6	45.68
2 nd	32	5144.6	2365	2779.6	45.97
3 rd	32	5144.6	2344	2800.6	45.56
4 th	32	5144.6	2371	2773.6	46.09
5 th	32	5144.6	2354	2790.6	45.76

From Table 1, 2, Fig. 2 it is observed that the machine operational consistency in terms of extraction rate and juice yield is very evident. Table 2 also shows that juice yield is at least 45 % of the mass of the charged fruit.

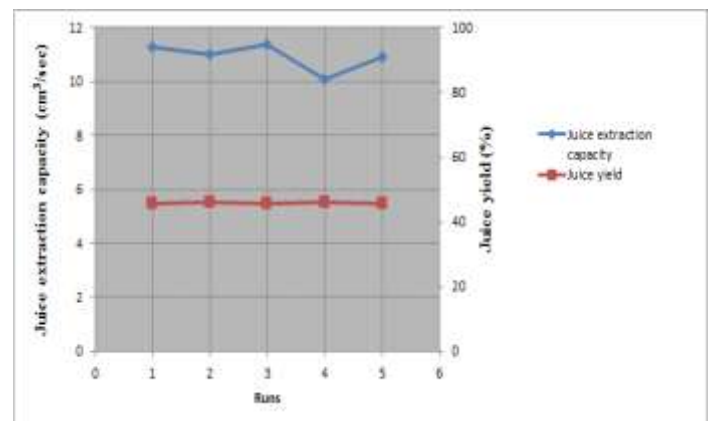

Fig. 2: Graph of Juice extraction capacity and Juice yield against Number of Runs

3.1 PERFORMANCE EVALUATION OF THE MACHINE

The average juice extraction capacity and average machine capacity from Table 1 is calculated as follows (Adejuyigbe & Bolaji, 2005):

$$\text{Average Capacity} = \frac{\sum R_i}{N}$$

Where:

R_i Correspond to the rate under consideration (juice extraction or mass crushed) at 'i' run ($i = 1, 2, \dots, 5$)

N is the total number of runs

The average juice extraction capacity is 10.92 cm³/sec or 39.312 lit/h while the average machine capacity is 10.8 g/sec or 38.89 kg/h.

The efficiency of the machine is given by:

$$\eta = \frac{\text{Average mass of extracted juice}}{\text{Average mass of rejected pulp, seed and skin per batch}} \times 100\%$$

$$\eta = 84.54\%$$

4 CONCLUSION

The design, fabrication, testing and performance evaluation of a motorized orange juice extraction machine was carried out. It was observed that the operation was consistent for the period of runs considered. The juice yield is at least 45 % of the mass of the charged fruit. Furthermore, the machine crushes 5.1446 kg of oranges in an average machine operating time of 3 min: 38 sec. The average juice extraction capacity, average machine capacity and machine efficiency were found to be 39.312 lit/h, 38.89 kg/h and 84.54 % respectively. The machine capacity appreciates compared to that which was reported by Olaniyan (2010) as 14 kg/h. Similarly, at 600 rpm the batch size is 32 oranges while that which was presented by Olabisi & Adelegan, (2015) is 20 oranges. Furthermore, the production cost of the machine is about N 117,800.00 (326 USD) compared to the imported GG-0.5 model of similar capacity which cost about 3150 USD, this makes the machine acquirable for use by both small and medium scale citrus juice processing plants in Nigeria.

ACKNOWLEDGEMENT

The authors wish to acknowledge the assistance of Mr. Oni. A.O., a former student of the Department of Mechanical Engineering, Federal University of Agriculture, Abeokuta Ogun State, Nigeria in the collection of data used for this work.

REFERENCES

- Abulude, F., Elemide, A., M.O. O., & Adesanya, W. (2007). Design and Performance Evaluation of Juice Extractor Constructed in Nigeria. *Research Journal of Applied Sciences*, 31-34.
- Adejuyigbe, S.B., and Bolaji, B.O., (2005). Design fabrication and performance evaluation of bean dehuller. *Journal of Science and Technology*, KNUST, Kumasi, Ghana, Volume 25(1), pp. 125-132.
- Adejuyigbe, S.B., and Bolaji, B.O., (2012). Development and performance evaluation of a rice de-stoning machine using vibrating sieves. *Journal of Natural Science, Engineering and Technology*, FUNAAB, Nigeria, Volume 11(2), pp. 94-105.
- Ahmed, I., Yeong, R., and Mir, S., (2015). Stress Analysis of Thin-Walled Pressure Vessels. *Modern Mechanical Engineering*, (5): 1-9 Available online at SciRes. <http://dx.doi.org/10.4236/mme.2015.51001>, Accessed on January 20, 2017.
- Aremu, A. K., & Ogunlade, C. A. (2016). Development and Evaluation of a Multipurpose Juice Extractor. *New York Science Journal*, 9(6).
- Bates, R.P., Morris, J.R., and Crandall, P.G., (2001). Principles and practices of small and medium scale fruit juice processing. *Agricultural services bulletin 146*. Food and Agriculture Organization of the United Nations. ISBN 92-5-104661-1.
- Bolaji, B.O., Adejuyigbe, S.B., and Ayodeji, S.P., (2008). Performance Evaluation of A Locally Developed Cassava Chipping Machine. *South African Journal of Industrial Engineering*, Volume 19 (1), pp. 169-178.
- Dhineshkumar. V., and Siddharth, M., (2015). Studies on Physical Properties of Orange Fruit. *Journal of Food Research and Technology*, Volume 3 (4), pp. 125-130.
- Earl, L.W., (2015). *Math Handbook of Formulas, Processes and Tricks*. Version 2.9. pp 76-77.
- Joseph, E.S., and Charles, R.M., (1996). *Standard Handbook of Machine Design*. Second Edition McGraw-Hill. United States of America, ISBN 0-07-056958-4.
- Ndubisi, A.A., Abubakar, A.L., Davou, S.N., and Jesutofunmi, B., (2013). Development and Performance Evaluation of a Multi-fruit Juice Extractor. *Global Journal of Engineering, Design and Technology*, Volume 2(2), pp. 16-21.
- Oguntuyi, V. F. (2013). Evaluation of development and performance of a manually operated orange juice extracting machine. *International Journal of Research Development*, 2(1), 257-26.
- Olabisi, O., & Adelegan, G. (2015). Design, Construction and Performance Evaluation of Citrus Fruits' Juice Extractor. *International Journal of Engineering Research & Technology (IJERT)*, 1372-1378.
- Olaniyan, A. M. (2010). Development of A Small Scale Orange Juice Extractor. *Journal of Food Science Technology*, 47(1), 105-108.
- Olife, I.C., Ibeagha, O.A., and Onwuaju, A.P., (2015). Citrus Fruits Value Chain Development in Nigeria. *Journal of Biology, Agriculture and Healthcare*, Volume 5(4), pp. 36-47.
- Oluwalana, I.B., (2006). Fruit Cultivation and Processing Improvement in Nigeria. *Agricultural Journal*, Volume 1(4), pp. 307-310.
- Ortese, E., Baiyeri, K.P., and Ugese, F.D., (2012). Demographic Features of Citrus Producers and Agronomic Management of the Crop in Benue State, Nigeria. *Production Agriculture and Technology*, Volume 8(1), pp. 180-190.
- Oyedele, O.O., & Yahaya, M.K., (2010). Citrus Farmers Production Constraints and Attitude to Training on Improved Techniques of Citrus Production. *Journal of Agriculture and Social Research*, Volume 10 (2), pp. 69-76.
- Sharifi, M., Rafiee, S., Keyhani, A., Jafari, A., Mobli, H., Rajabipour, A., and Akram, A., (2007). Some physical properties of orange (var. Tompson). *International Agrophysics*, Volume 21, pp. 391-397.
- Shigley, J. E., & Mitchell, L. O. (1983). *Mechanical Engineering Design* (4th ed.). Tokyo: McGraw Hill Int Book Co.
- Sylvester, A.A., and Abugh, A., (2012). Design and Construction of an Orange Juice Extractor. *Proceedings of the World Congress on Engineering 2012 Volume III WCE 2012*, July 4 - 6, 2012, London, U.K.
- United States Department of Agriculture (2017). *Citrus: World Markets and Trade*.