

Design and Implementation of a Compact Home Security System

*¹Mathurine Guiawa, ²Temidayo J. Ofusori, ²Kehinde O. Olusuyi, ²Hilary U. Ezea and ²Adedayo Babarinde

¹Department of Electrical & Computer Engineering, Igbinedion University, Okada, Edo State, Nigeria

²Department of Electrical & Electronics Engineering, Federal University Oye-Ekiti, Ekiti State, Nigeria

mathurineabouo@gmail.com | {temidayo.ofusori | kehinde.olusuyi | hilary.ezea | adedayo.babarinde}@fuoye.edu.ng

Abstract— This paper presents the design and implementation of a compact home security system. The use of security systems in today's home where safety is an important issue cannot be over emphasized. The high crime rates and domestic hazards has brought up the need to take proper measures to prevent intrusions and hazards. It is in this regard that the design and implementation of a compact home security system based on the Global System for Mobile communication (GSM) comes in. Previous designs have used finger print protection, password protection, speech recognition, sensors with buzzer alarms, SMS and e-mail alerts but the designs were with so many complexities as well as at a cost disadvantage. The system presented here is of a minimal cost and simple design; it consists of one motion sensor, one temperature sensor, and one gas sensor. The system was designed using the ATMEGA 8 microcontroller which controls the sending of SMS to the authorized number. The motion sensor (infrared) detects the movement of people entering the house and when there is a detection of an intruder the owner is notified through an SMS. The temperature sensor in this system also initiates an SMS to the owner when the temperature exceeds a particular value. The gas sensor also works in similar manner when it detects smoke and gas thereby sending SMS alert to the owner of the house. The respective sensors detected the compromise in each situation and sent the corresponding SMS to the user. This device therefore helps to prevent intruders, accidents arising from harmful gases and fire outbreaks in homes, offices and industries.

Keywords— Alarm, GSM, Home, Security, Sensors

1 INTRODUCTION

One of the fastest emerging technological measures of security in the world today is the home security system. This is basically so because it is not enough to have a comfortable place to live if one's safety is not guaranteed. The era of wireless technologies and communication has provided a means to safe guard homes from intruders and hazards even when one is far from home. Home security can be described as homes that are fully secured in terms of preventing unauthorized entry and unforeseen accidents as well as providing feedback to users by responding accordingly to situations. In other words, it simply allows many aspects of the system such as emergency response and security monitoring systems to be properly set up.

Home security systems play an important role of providing security through user notification to prevent or arrest break-ins at entry points and also to prevent accidents of various forms. Compact home security systems aim at developing the security of homes against intruders, gas leakage and fire. In any of the above cases, the device sends SMS to the emergency number provided to it and thus helps in quickly taking necessary actions. A review of related work was carried out to improve the various design stages involved followed by the hardware and software design then comes the implementation and thereafter the various stages were monitored and tested for compliance.

2 REVIEW OF RELATED WORK

Sumangala & Ram (2012) developed a home security system using sensors to detect security violation and sends alert signal via a high intensity Buzzer. It also provided Double Authentication i.e. the door could only be opened with the right password and right key.

Agarwal & Nayak (2013) constructed a micro-controller based automated home security system where the door lock was password protected with an LED based resistive screen input panel. It's operation is based on the detection of the difference in light intensity.

Bangali & Shaligram (2013) designed and implemented a security system for smart home which was based on GSM technology. When the camera detects motion, an alert in the form of sound and a mail is sent to the owner.

Omorogiuwa & Elechi (2014) designed and constructed a GSM intelligent home security system for real time monitoring of intruders. When there is an intruder, the relevant sensing device(s) respond and the microcontroller sends encoded alarm signal to the wireless sensor network established in the home. As soon as the alarm signal is received, a short message service (SMS) is sent to the users through GSM network.

Hasan *et al* (2015) designed and implemented microcontroller based home security system with GSM technology. The operation is based on interfacing a mobile phone with microcontroller through a bluetooth device in order to control the system. Saha & Bhaumik (2011) presented a total remote control security system based on SMS technology using any GSM modem/mobile

Azid & Kumar (2011) studied the performance of the sensors of a low cost Short Message System (SMS) based home security system equipped with motion sensor, smoke detector, temperature sensor, humidity sensor and light sensors. Butt *et al* (2011) focuses on understanding the speech or voice of user, controlling the home appliances through voice call and finding

*Corresponding Author

intrusion in the house. The system was implemented using voice Global System for Mobile Communications (GSM) and wireless technology based on .NET framework as well as Attention (AT) commands.

This paper considers the design and implementation of a compact home security system. It makes use of motion, gas and temperature sensors in a unique and compact integration with a microcontroller. SMS is sent to the user when any one or more of the sensors detect compromise in the original state.

3 HARDWARE DESIGN

3.1 Power Supply

Power supply is a reference to a source of electrical power. A device or system that supplies electrical or other types of energy to a load or group of loads is called a power supply unit (PSU). The term is most commonly applied to electrical energy supplies, less often to mechanical ones, and rarely to others. A 5volts DC power supply is needed for the different component parts. A transformer was used to step down the voltage from the mains supply, after which a bridge rectifier was used for full wave rectification. The rectified output was filtered using a filtering capacitor and finally a 5V voltage regulator was used to stabilize the output as shown in Fig. 1.

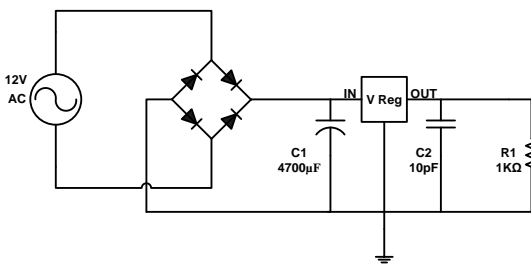

Fig. 1: Power Supply Circuit

3.2 Gas Sensor (MQ-6)

This sensor has a high sensitivity and fast response time. The sensitive material of MQ-6 gas sensor is SnO₂ known as Tin dioxide (stannic oxide), which has lower conductivity in clean air. When the target combustible gas exist, the sensor's conductivity is higher along with the gas concentration rising. A simple electronic circuit is used to convert change of conductivity to corresponding output signal of gas concentration. MQ-6 gas sensor has high sensitivity to Propane, Butane and liquefied petroleum gas (LPG), it also responds to Natural gas. The MQ-6 can detect gas concentrations anywhere from 200 to 10000ppm. The sensor's output is an analog resistance. The coil is powered with 5V, then a load resistance is added and eventually the output is connected to an ADC. Fig. 2 shows the gas sensor circuit.

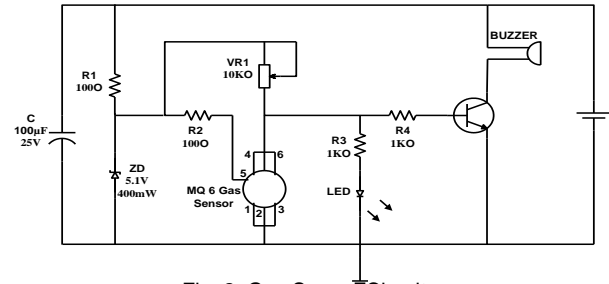

Fig. 2: Gas Sensor Circuit

3.3 Motion Sensor (PIR Sensor)

Passive Infra-Red (PIR) sensor allows you to sense motion, it is used to detect if a human has moved in or out of a sensor range by measuring infrared (IR) light radiating from objects in its field of view. They are small, inexpensive, low power, easy to use and do not wear out. For that reason they are used in homes, offices and are found in appliances as well. They are also referred to as Infra-Red (IR) motion sensors. PIRs are basically made of a PYROELECTRIC material which can detect levels of infrared radiations. The sensor in a motion detector is split into two halves in order to detect motion (change) and not average IR levels. The two halves are wired up so that they cancel each other out. If one half sees more or less IR radiation than the other, the output will swing high or low accordingly.

3.4 Temperature Sensor

These are optoelectronic devices which measure temperature by means of optical fibres functioning as linear sensors. Temperatures are recorded along the optical sensor cables, thus not as points but as a continuous profile and as such a high accuracy of temperature is achieved over great distances. Typically the distributed temperature sensing system can locate the temperature to a special resolution with accuracy within +/-1 degree Celsius at a resolution of 0.01 degree Celsius. This temperature sensor is an analogue type and it is a chip that tells what ambient temperature it is. Solid state techniques are used to determine temperature. In other words the fact that temperature has increased, the voltage across the diode increases at a known rate as well. The block diagram of the entire system and complete circuit diagram are shown in Fig. 3 and Fig. 4 respectively.

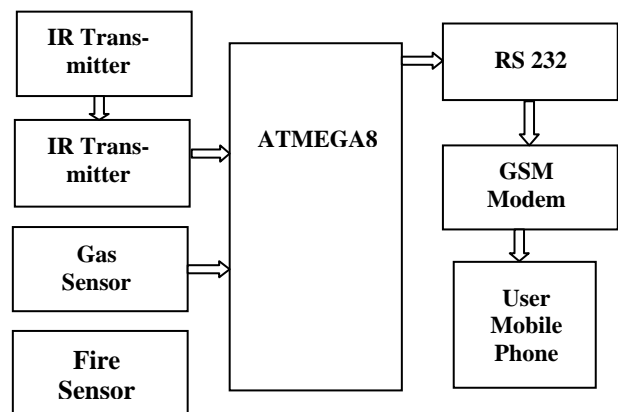

Fig. 3: Block Diagram of Home Security System

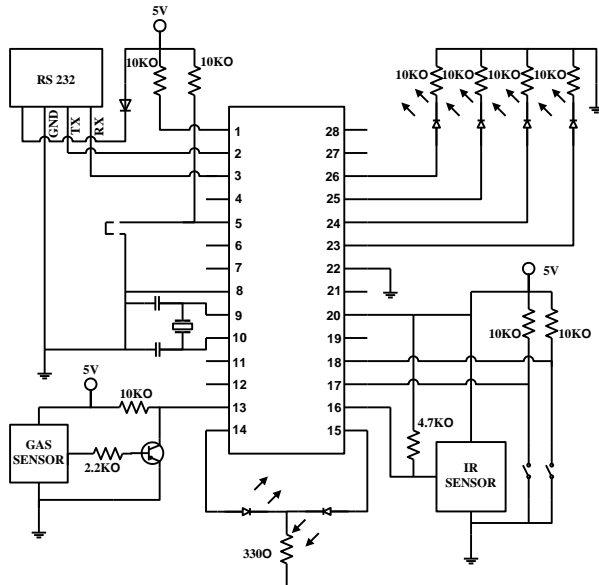

Fig. 4: Complete Circuit Diagram

4 SOFTWARE DESIGN

Pony Prog (Serial Device Programmer) was used in the software design, it is a simple but powerful programmer; it is a serial device programmer software with a user friendly GUI framework available for windows 95/98/ME/NT/2000/XP and Intel Linux as seen in Fig. 5. Its purpose is reading and writing every serial device. At the moment it supports I2C BUS, micro wire, SPI eeprom, the Atmel AVR,AT89S micro and microchip PIC micro.

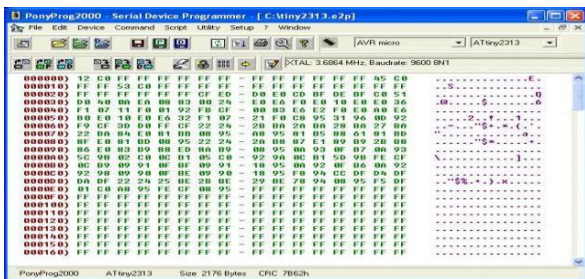

Fig. 5: Pony Prog Graphics User Interface

SI PROG is the programmer hardware interface for pony prog. With pony prog and SI prog, the wafer card for SAT, EEPROM within GSM, TV or CAR-RADIO can be programmed. Any HEX file, e2p, mot, csm, rom, eep, bin files can be opened and burn to uC or PIC. Old programs on the chip can be backed up using pony prog. Saving of HEX file to BIN file or eep file, BIN file to HEX file or MOT file and vice versa. It offers serial or parallel port programming for uC's. The polarity can be changed without touching the wires using I/O port setup. It allows setting of program options to erase file, reload file, read data memory (EEPROM), read program memory (FLASH), set serial number, write program memory (FLASH), write data memory(EEPROM), write security and configuration bits. Fig. 6 shows the flow chart of the system design.

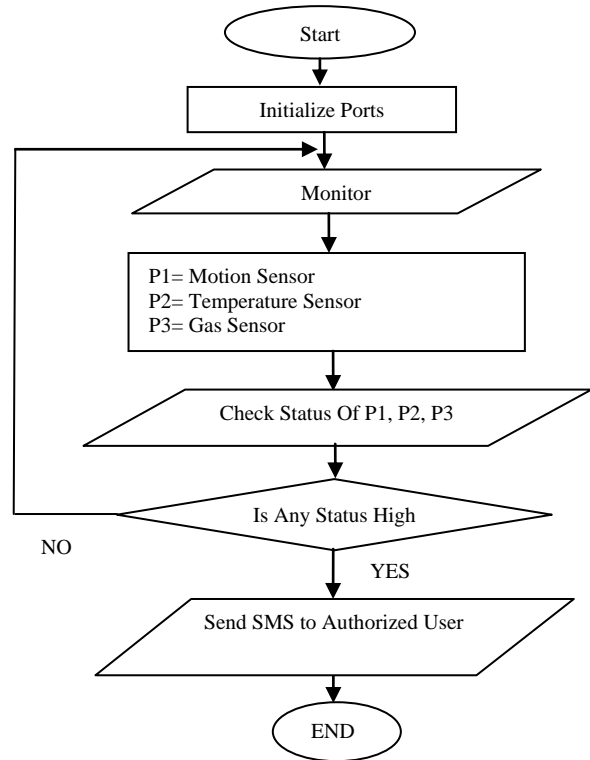

Fig. 6: System Design Flow Chart

5 IMPLEMENTATION

The home security system using GSM for transmission is made up of a number of sensors to detect different situations. The whole system is controlled by atmega8 microcontroller which continuously reads the status of the sensors, if any of the sensors detects a corresponding compromise then it sends an SMS to the house owner. The ATmega8 test circuit and pin layout are shown in Fig. 7 and Fig. 8 respectively.

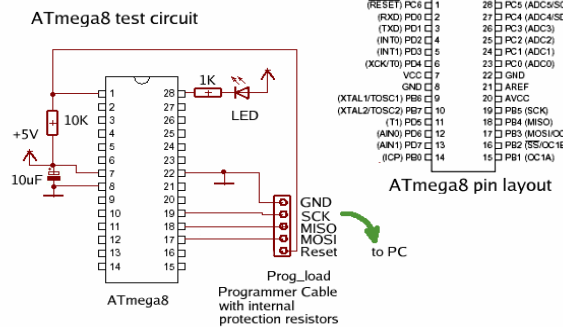

Fig. 7: ATmega8 Test Circuit

Fig. 8: Pin Layout

The authorized owner number was stored by closing the jumper and switch on the circuit. After initiating the modem the microcontroller will wait for the password through SMS. The default password was set as "microcontroller" and the microcontroller stores the mobile number into its EEPROM memory. After all the above the jumper is removed so that the microcontroller

can enter the monitoring mode. It continuously checks the sensors and if any of the sensor detects a corresponding compromise, then it sends SMS to the number stored in the memory.

MQ 6 Gas sensor was used as a Sensor for LPG, Butane and Propane so that an alert is triggered when there is leakage of these gases from the source. MQ6 is a highly sensitive gas sensor to petroleum based gases but less sensitive to Alcohol and Carbon-dioxide. This simple sensor was installed in the kitchen to give an alert if there is leakage of LPG. MQ6 gas sensor is a 6 pin device that requires 5 volts DC maximum which is derived from a power supply regulated by a 5v regulator. There is a heating element inside the sensor which becomes hot at 5 volt and remains stand by. When the sensor detects gas molecules between 100 ppm to 1000 ppm, in the atmosphere, its output turns high and triggers the transistor whose output is fed to the appropriate input of the microcontroller. The red LED indicates the high output from the sensor. The unit is fixed about 1 to 2 meters away from the burner or gas cylinder and the sensitivity of the unit was adjusted through a variable resistor for maximum sensitivity.

6 MONITORING AND TESTING

The design of home security system made use of PIR sensor as motion detector. This was extended to an enclosed area of choice, when the intruder circuit detected movement in the enclosed area which increased the infra-red radiation, it triggered the circuit to send the required SMS.

MQ 6 Gas sensor which is highly sensitive to petroleum based gases was used as a sensor for LPG, Butane and Propane so that an alert is triggered when there is leakage of these gases. The sensor was installed about 1 to 2 meters away from a gas cylinder and the sensitivity of the unit was adjusted through a variable resistor for maximum sensitivity, when the gas detector circuit sensed LPG, natural gas and smoke in a higher concentration than normal, it responded by sending SMS.

When the sensor detects gas molecules between 100 ppm to 1000 ppm, in the atmosphere, its output turns high and triggers the transistor whose output is fed to the appropriate input of the microcontroller and hence initiates a corresponding SMS. The red LED indicates the high output from the sensor

7 RESULTS AND DISCUSSIONS

It was observed that when the system boots normally (i.e. when the jumper is connected), It takes 3.65 seconds for the 1st base light to start blinking (i.e the LED at PIN14), It takes 2.18 mins. to flip to the 2nd base light (i.e the LED at PIN 15). When the jumper is not connected, as the second base light starts it will swing with the other base light in less than a second this degenerates to the other LEDs (i.e. the sensors lights at PINs 23,24,25,26)

Fig. 9 shows the message sent to the authorized number when the intruder circuit detected movement in an enclosed area which increased the infra-red radiation and as a result triggered the circuit to send the required SMS.

Fig. 10 shows the message sent to the authorized number when the gas detector circuit sensed LPG, natural gas and smoke in a higher concentration than normal, the higher the concentration the higher the conductivity as well and hence initiated a corresponding SMS. Fig. 11 shows the message sent to the authorized number when the temperature sensing circuit detected a temperature that was above a particular threshold, this automatically sent an appropriate SMS.



Fig. 9: Motion SMS

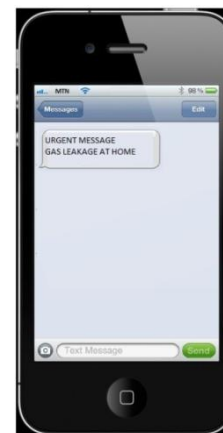

Fig. 10: Gas SMS

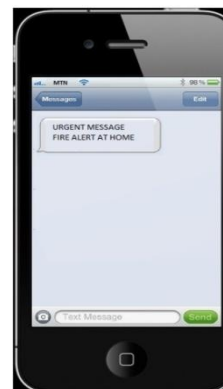

Fig. 11: Fire SMS

Bangali & Shaligram (2013) used sound alert and e-mail which makes it quite complex. The use of e-mail also makes it a luxury to those who do not regularly have internet connection. The Encoded alarm of Omorogiuwa & Elechi (2014) makes the design complex as well. The control via Bluetooth instead of GSM of Hasan *et al* (2015) increased the complexity of the design and the speech recognition design of M. Butt *et al* (2011) was another complex design entirely. The design presented in this paper is quite a simple one which is also pocket friendly without compromising its security function.

Sudipan Saha, Sutasom Bhaumik (2011) "SMS based wireless global range automation & Security system" - IEMCON.

8 CONCLUSION

The design and implementation of a compact home system was successfully implemented after the design stages, the respective sensors detected the compromise in each situation and sent the corresponding SMS to the user. It was tested and proven to be a reliable form of home security alert system as intrusions can be avoided or spotted respectively by sending the appropriate message to the owner. The system is also compact and cost-effective as compared to the previously existing systems however it is extensible so that more sensors can be included for an all encompassing outcome.

REFERENCES

- All Datasheet (2016), www.alldatasheet.com, accessed July 2016
- B. V. Sumangala and K. Bhargava. Ram (2012), "Design, Development and Performance Study of L3- Home Security System" Published by Global Journal of Researches in Engineering Electrical and Electronics Engineering, Vol. 12 Iss. 8
- Datasheet Catalog (2016), www.datasheetcatalog.com, accessed July 2016
- Dual EIA-232 driver/receiver (2016), Max data sheet Texas from www.ti.com, accessed July 2016.
- Jayashri Bangali and Arvind Shaligram (2013), "Design and Implementation of Security Systems for Smart Home based on GSM technology" Published by International Journal of Smart Home Vol.7, No.6, pp.201-208.
- Marriam Butt, Mamoona Khanam, Aihab Khan, Malik Sikandar Hayat Khiyal (2011), "Controlling Home Appliances Remotely Through Voice Command", International Journal of Advanced Computer Science and Applications (IJACSA), Special Issue on Wire-less & Mobile Networks, pp. 35-39.
- Nikhil Agarwal, G. Subramanya Nayak (2013), "Microcontroller based Home Security System with Remote Monitoring", International Journal of Computer Applications (IJCA) Special Issue on Electronic Design and Signal Processing.
- Omorogiuwa Eseosa, Elechi Promise (2014), "GSM Based Intelligent Home Security System for Intrusion Detection" Published by International Journal of Engineering and Technology, Vol. 4 No. 10.
- Raqibull Hasan, Mohammad Monirujjaman Khan, Asaduzzaman Ashek, Israt Jahan Rumpa (2015), "Microcontroller Based Home Security System with GSM Technology" Published by Open Journal of Safety Science and Technology, 5, 55-62.
- Sheikh Izza Azid and Sushil Kumar (2011), "Analysis and Performance of a Low Cost SMS Based Home Security System", International Journal of Smart Home, Vol. 5, No. 3.