



January 2012

Evaluation Of Paradigms For A P300 Based Brain Computer Interface Speller

Scott Gavett

Follow this and additional works at: <https://commons.und.edu/theses>

Recommended Citation

Gavett, Scott, "Evaluation Of Paradigms For A P300 Based Brain Computer Interface Speller" (2012). *Theses and Dissertations*. 1239.
<https://commons.und.edu/theses/1239>

This Thesis is brought to you for free and open access by the Theses, Dissertations, and Senior Projects at UND Scholarly Commons. It has been accepted for inclusion in Theses and Dissertations by an authorized administrator of UND Scholarly Commons. For more information, please contact zeinebyousif@library.und.edu.

EVALUATION OF PARADIGMS FOR A P300 BASED BRAIN COMPUTER
INTERFACE SPELLER

by

Scott Gavett
Bachelor of Science, University of North Dakota, 2010

A Thesis

Submitted to the Graduate Faculty

of the

University of North Dakota

in partial fulfillment of the requirements

for the degree of

Master of Science

Grand Forks, North Dakota

May
2012

This thesis, submitted by Scott Gavett in partial fulfillment of the requirements for the Degree of Master of Science from the University of North Dakota, has been read by the Faculty Advisory Committee under whom the work has been done and is hereby approved.

Reza Fazel-Rezai

Chairperson

Reza Fazel-Rezai 05/02/12

G.P. Mads

This thesis meets the standards for appearance, conforms to the style and format requirements of the Graduate School of the University of North Dakota, and is hereby approved.

Naquale Sinden

Dean of the Graduate School

5-8-12

Date

PERMISSION

Title: Evaluation of Paradigms for a P300 Based Brain Computer Interface
Speller

Department: Electrical Engineering

Degree: Master of Science

In presenting this thesis in partial fulfillment of the requirements for a graduate degree from the University of North Dakota, I agree that the library of this University shall make it freely available for inspection. I further agree that permission for extensive copying for scholarly purposes may be granted by the professor who supervised my thesis work, or in his absence, by the chairperson of the department or the dean of the Graduate School. It is understood that any copying or publication or other use of this thesis or part thereof for financial gain shall not be allowed without my written permission. It is also understood that due recognition shall be given to me and to the University of North Dakota in any scholarly use which may be made of any material in my thesis.

Signature

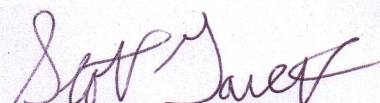

Date

4/24/12

TABLE OF CONTENTS

LIST OF FIGURES	vii
LIST OF TABLES	x
ACKNOWLEDGMENTS	xi
ABSTRACT	xii
CHAPTER	
1. BACKGROUND AND LITERATURE REVIEW	1
1.1 Introduction.....	1
1.2 The Human Brain.....	1
1.3 EEG and Data Collection.....	3
1.4 P300 Component of Event Related Potentials.....	4
1.5 Brain Computer Interface	5
1.6 Brain Computer Interface Inputs	6
1.7 BCI Paradigm Design	7
1.8 Row/Column Paradigm.....	8
1.9 Single Character Paradigm	8
1.10 Region Based Paradigms	9
1.11 Checkerboard Paradigm.....	10
1.12 Signal Processing and Classifier Training	13
1.12.1 Linear Discriminant Analysis	13
1.12.2 Support Vector Machines	14
1.12.3 Stepwise Linear Discriminant Analysis.....	14

1.13	Row/Column Paradigm Visual Modifications.....	14
1.14	Challenges in P300 Brain Computer Interface	17
1.15	Crowding Effect and Adjacency Problem	18
1.16	Double Flash	19
1.17	Applications of P300 Brain Computer Interface	20
1.18	Lie Detector	20
1.19	Virtual Speller	21
1.20	Smart Home	21
2.	METHODS AND MATERIALS.....	23
2.1	Experiments	23
2.2	Ethical Approval	24
2.3	Equipment.....	24
2.4	Test and Paradigms.....	26
2.5	Data Analysis and P300 Detection	27
2.6	Questionnaire	29
3.	RESULTS AND DISCUSSION.....	30
3.1	Experiments	30
3.2	Comparison of SC, RC, RB1, and RB2.....	30
3.2.1	Subjects.....	30
3.2.2	Accuracies of Paradigms.....	31
3.2.3	Region Errors	32
3.3	Errors per Region in an RB Paradigm	33
3.4	Comparison of SC, RC, and RB2	34
3.4.1	Subjects.....	35
3.4.2	Accuracies of Paradigms.....	35

3.4.3	Adjacency Results.....	43
3.4.4	Region Error.....	46
3.4.5	Questionnaire Results	47
4.	CONCLUSION.....	57
4.1	Conclusion	57
4.2	My Contributions.....	57
4.3	Future Works	59
	APPENDICES	60
	A – BCI Subject Questionnaire	61
	B – Subject Questionnaire	62
	C –Results from the comparison of SC, RC, RB1, and RB2 Paradigms.....	63
	D –Results from the Errors per Region experiment	75
	E – Results from the comparison of SC, RC, and RB2 Paradigms	83
	F – Informed Consent	106
	G – BCI Test Plan.....	110
	REFERENCES	113

LIST OF FIGURES

Figure	Page
1.1 Structure of a neuron cell.....	2
1.2 The change in potential by closing the Na ⁺ channels and opening the K ⁺ channels	3
1.3 Beta, Alpha, Theta, and Delta waves graphically represented	4
1.4 6x6 matrix of characters used by Farwell and Donchin in 1988	6
1.5 ERP at electrode location Cz to the visual oddball target processing. The curves show the P300, P200, N100, and N200	7
1.6 Row/Column paradigm introduced by Farwell and Donchin in 1988.....	8
1.7 (left) RB1 at the first level where region 1 is selected, (right) RB1 paradigm at the second level where the seven characters in this region are expanded on the screen	10
1.8 CB paradigm with the two 6x6 matrices superimposed	11
1.9 CB paradigm flashing 6 random characters.....	11
1.10 CB two 6x6 matrices that are randomly selected.....	12
1.11 White and black background visual paradigms	15
1.12 Large and small inter symbol distance visual paradigm.....	16
1.13 Large and small symbol size visual paradigm	16

1.14	EEG with blinking artifacts	17
1.15	Error distribution for the RC paradigm.....	18
1.16	Error distribution for the CB paradigm.....	19
1.17	EEG data for a subject who is knowledgeable regarding the investigated event .	20
1.18	EEG data for a subject who is not knowledgeable regarding the investigated event	21
1.19	(left) Control mask with the main menu in the first 2 rows, the icons for the camera, door control and questions in the 3rd and 4th row and the TV control in the last 2 rows. (right) Control mask for going to a specific position in the smart home. The mask gives a bird’s eye view of the apartment with characters at specific positions.....	22
2.1	Electrode location using the based on the international 10-20 system	23
2.2	(top left) g.GAMMAbox, (top right) g.GAMMAusb, (bottom left) g.GAMMAearclip, (bottom middle) g.LADYbird, (bottom right) g.LADYbirdGND	25
2.3	g.GAMMAcap product of g.tec	25
2.4	(left) The abrasive gel (right) the conductive gel.....	26
2.5	EEG from subject 4 showing a P300	28
3.1	Accuracy for the word ‘WATER’ for each subject and each paradigm.....	31
3.2	Accuracy for the word ‘LUCAS’ for each subject and each paradigm	32
3.3	Errors per region results from a study in 2010	33
3.4	Average errors per region for the errors per region experiment	34
3.5	Modified 6x6 matrix for this experiment.....	35
3.6	Accuracy by paradigm and by word	38
3.7	Interaction plot for Accuracy	38
3.8	Percentage of errors per region for the RB2 paradigm for all 23 subjects	46
3.9	SC questions from the subject questionnaire form in Appendix B – Subject Questionnaire.	47

3.10	RC questions from the subject questionnaire form in Appendix B – Subject Questionnaire.....	48
3.11	RB2 questions from the subject questionnaire form in Appendix B – Subject Questionnaire.....	49
3.12	Results from question 1 and 7 of the brain computer interface subject questionnaire found in Appendix A – BCI Subject Questionnaire.....	52
3.13	Results from question 2-4 of the brain computer interface subject questionnaire found in Appendix A – BCI Subject Questionnaire	53
3.14	Results from question 8-10 of the brain computer interface subject questionnaire found in Appendix A – BCI Subject Questionnaire	53
4.1	Predictive region based paradigm.....	59

LIST OF TABLES

Table	Page
1.1 Brain waves and frequencies	4
1.2 List of characters in level 1 in RB1 and RB2	9
1.3 Selections per minute and practical bit rates of RC and CB with taking error correction into account.....	13
2.1 Amount of time required to spell one character per paradigm	27
3.1 Average accuracy of each paradigm for all subjects averaged for three trials	37
3.2 Two-way ANOVA test for all three paradigms.....	39
3.3 Post hoc Tukey test for all three paradigms.....	40
3.4 Two-way ANOVA test for all three paradigms with the outliers removed.....	40
3.5 Post hoc Tukey test for all three paradigms with the outliers removed.....	41
3.6 Two-way ANOVA test for the RC and RB2 paradigms.....	41
3.7 Post hoc Tukey test for the RC and RB2 paradigms	42
3.8 Two-way ANOVA test for the RC and RB2 paradigms with the outliers removed	42
3.9 Post hoc Tukey test for the RC and RB2 paradigms with the outliers removed ..	43
3.10 Adjacency errors of the single character paradigm.....	44
3.11 Adjacency errors of the row/column paradigm	45
3.12 Adjacency errors of the region based paradigm	45

ACKNOWLEDGMENTS

The author greatly appreciates the efforts of the Electrical Engineering department, especially Dr. Reza Fazel-Rezai, my advisor and head of the Biomedical Research And INovation (BRAIN) Team at the Biomedical Image and Signal Processing Laboratory. His constant support and mentoring were essential in the achievement of this thesis.

The author also appreciates the participation and contributions of his committee members, Dr. Arthur Miles and Dr. Saleh Faruque.

The author would also like to thank fellow students that have helped with this project, Waqas Ahmad, Ahmed Rabbi, Eric Schneider, and Zach Wygant.

The author would like to thank every subject for taking the time to help with the experiments over the years.

The author would like to thanks his family, Mark, Debbie, Steve, and Shawn Gavett, for being supportive and caring along with his loving girlfriend Kristin Johnson.

Lastly, the author would like to note that the late Dr. Richard R. Schultz still has a positive impact on him today and he is grateful that Dr. Schultz inspired him to write this thesis.

ABSTRACT

This thesis was written to compare a few different paradigms for the brain computer interface (BCI) virtual speller using the P300 signal. The paradigms consist of electrodes to record electroencephalogram signal (EEG), software to analyze the data, and a computer where the subject's EEG is the input for a virtual keyboard. There were three experiments that were constructed to test the accuracy, region error, and adjacency error among the paradigms. The first experiment was the comparison of four paradigms: the single character (SC), row/column (RC), region based 1 (RB1), and region based 2 (RB2) paradigms. Six subjects were considered for that experiment and the accuracy of each paradigm and region errors were considered. The second experiment was designed to determine the errors per region for the region based paradigm. Eight subjects were considered for this experiment and the results concluded that region 4 (middle of the paradigm) had the most errors. The last experiment performed was the comparison of the SC, RC, and RB2 paradigms. This experiment took into consideration the accuracies of each paradigm, region errors, along with errors due to the adjacency problem. Overall, the three experiments shared the same results with the RB paradigms being slightly better than the RC paradigm in accuracy and both the RC and RB paradigms being statistically better than the SC paradigm.

Chapter 1. Background and Literature Review

1.1 Introduction

The comparison of P300 based Brain Computer Interface (BCI) paradigms will be helpful to determine which paradigm has a higher accuracy, speed, and user acceptance. In this thesis, the four paradigms that are compared are the Single Character (SC), Row/Column (RC), Region Based 1 (RB1), and the Region Based 2 (RB2) paradigms. In this chapter, we will discuss the human brain and the electrical signals that it generates, how a BCI system works, and different types of BCI.

1.2 The Human Brain

A brief description of the human brain will help in a better understanding of the brain computer interface system. A neuron is a nerve cell that sends an electrical signal through the body [1]. The neuron is composed of a cell body with dendrites around that with a tail-like Axon extending to the other neurons dendrites. The axons are coated in a fatty myelin sheath which helps speed up the neuron signal and helps to protect the cell [2]. Figure 1.1 shows in detail what a neuron cell looks like.

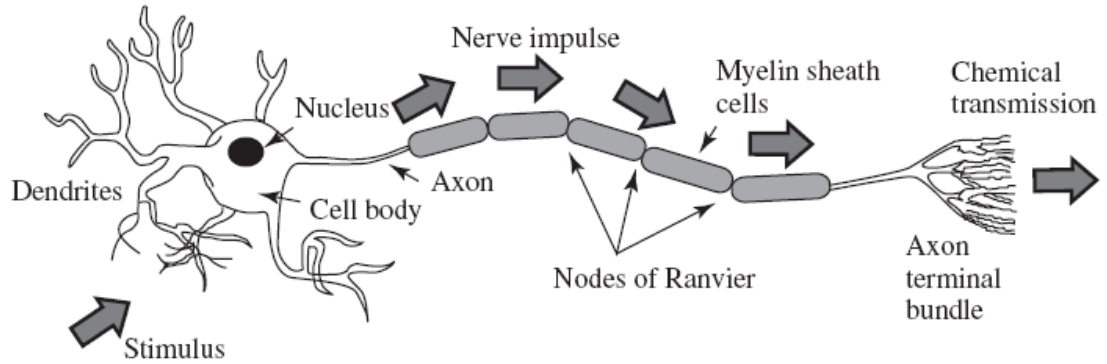

Figure 1.1 Structure of a neuron cell [3]

The other part of the brain that is important are the glial cells, these were believed to be support cells for the neuron cells. However, recent research has shown that these cells can also engage in interactions with synapses during neurotransmissions. They can respond to neurotransmission, modulate neurotransmission, and instruct the development, maintenance, and recovery of synapses [4]. The electricity that is generated in the brain is due to the sodium potassium pumps at the cellular level. The pumping of Na^+ (Sodium), K^+ (Potassium), Ca^{++} (Calcium), and the negative ions of Cl^- (Chlorine) through the cell membranes generate current in the brain [5]. The neuron sends a signal to another neuron which then starts to pump Na^+ increasing the positive electrical charge from -70mV to -50mV as soon as the action threshold is met it is additional Na^+ pumps open and the voltage is now at $+30\text{mV}$. Also, at this time the K^+ channels open and the potential starts to go back to its natural state of -70mV . It over shoots its resting voltage going down to -90mV called hyperpolarization [5]. Figure 1.2 shows a graphical representation of this electrical potential of the neuron cell. The electrical signal in the brain is called Electroencephalogram (EEG) which was first recorded by Hans Berger in 1924 [6].

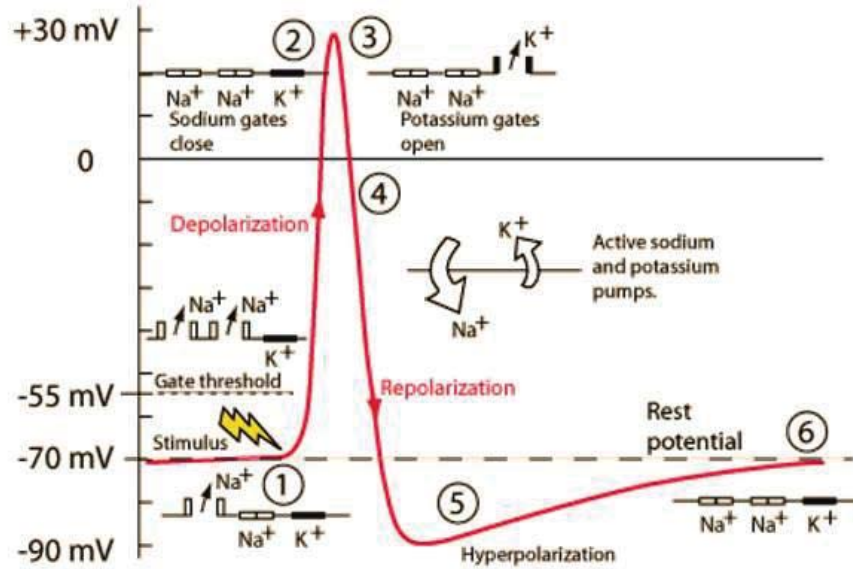

Figure 1.2 The change in potential by closing the Na⁺ channels and opening the K⁺ channels [7]

1.3 EEG and Data Collection

Hans Berger was the first person to record any electrical signal from the human brain. He coined the term electroencephalogram (EEG) in 1924; he characterized the wave patterns including Alpha and Beta [6]. The electrical signals that the brain produces can be measured by placing electrodes on the scalp to measure a potential between two points. Usually for noninvasive techniques a conductive gel is used between the scalp and the electrode to increase conductivity. Berger discovered the Alpha wave which occurs at a relaxed state of awareness without any attention or concentration [5]. He also discovered the Beta wave which is associated with active thinking, attention, focusing on the outside world, and solving difficult problems [5]. These are not all the waves that are found in the brain; there are three more important waves to be discussed; Delta, Gamma, and Theta waves. The Delta wave is associated with deep sleep and may be present in a waking state [5]. The Gamma waves have low amplitudes and are rare in the brain [5]. Finally, the Theta waves appear when a person

is drowsy [5]. In Table 1.1, the different frequencies for each wave band are shown; in Figure 1.3 graphical representations of those waves are shown.

Frequency band name	Frequency range (Hz)
Delta	0.5 – 4
Theta	4 – 7.5
Alpha	8 – 13
Beta	14 – 26
Gamma	>30 (mainly up to 45 Hz)

Table 1.1 Brain waves and frequencies [5]

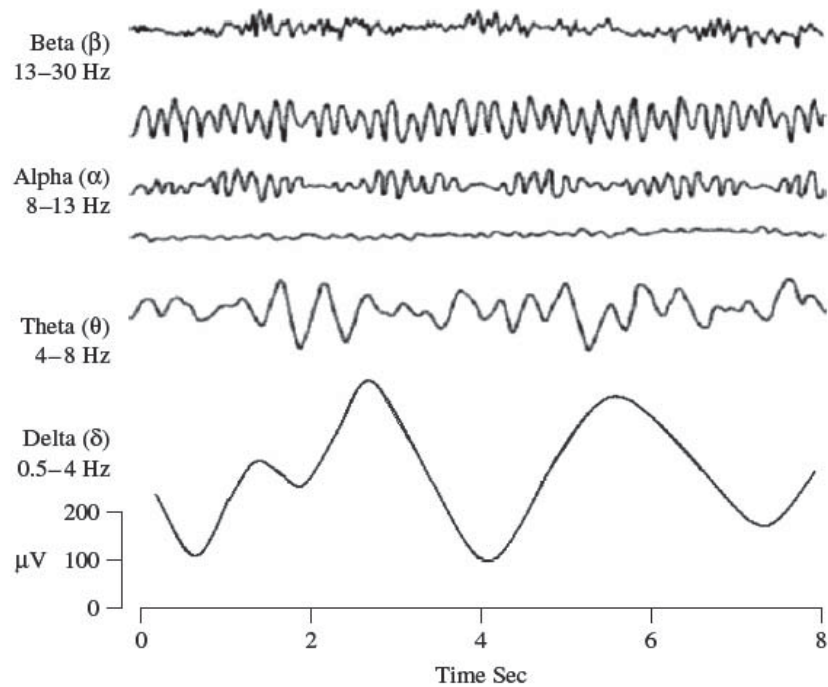

Figure 1.3 Beta, Alpha, Theta, and Delta waves graphically represented [5]

1.4 P300 Component of Event Related Potentials

The P300 wave is a positive peak in the human event-related potential [8]. It is most commonly elicited in an "oddball" paradigm when a subject detects a rare "target" stimulus [8]. The P300 amplitude varies with the improbability of the targets [9]. The

P300 amplitude can be represented as a function dependant on subjective probability (P), stimulus meaning (M), and overall stimulus information transmitted to the subject (T) [9].

$$P300 \text{ Amplitude} = f \left[T \times \left(\frac{1}{P} + M \right) \right] \quad (1.1)$$

Latency of the P300 signal varies with the difficulty of discriminating the target stimulus from the non-target stimuli [8]. Normal peak latency when a young adult subject makes a simple discrimination is 300 ms after the stimulus [10].

1.5 Brain Computer Interface

“Brain-computer interface is a communication system that does not depend on the brain’s normal output pathways of peripheral nerves and muscles” [11]. The concept of the brain computer interface was first introduced during the early 1970’s by a ULCA researcher Jacques Vidal [12]. Vidal tried to have the evoked potentials to be an input to a computer. Simply said, a BCI system is the connection between a brain and a computer. The purpose of BCI is to bypass the normal paths of the signal to control the outside world. The reason someone would want to do this is if their normal outputs from the brain were damaged, such as people with amyotrophic lateral sclerosis (ALS), spinal cord injury, and many other diseases or injuries [5,13-15]. It was not until 1988 that L. A. Farwell and E. Donchin (FD) developed a virtual speller brain computer interface using the P300 component of the event related potentials (ERPs) [13]. FD used a 6x6 matrix of characters that flashed rows and columns which then determined the intended character by the intersection of the row and column with the most P300’s detected. Figure 1.4 was taken from Farwell and Donchin’s 1988 paper ‘talking off the top of your head: toward a mental prosthesis utilizing event-related brain potentials’ [13]. In 1995, there were no more than six groups doing research in the area of BCI, today it is growing

and there is so much more researchers looking into this challenging area [11]. Brain computer interface can be separated into three different components: 1.) The BCI paradigm design, 2.) signal processing and feature extraction, 3.) classifier training. All of these components are described in more detail in [16]. Recently, there has been research to change the visual aspects of the RC paradigm to see whether these minimal changes positively affect the speller paradigm [16]. Some of these changes will be described more in section 1.13.

BRAIN

Choose one letter or command

A	G	M	S	Y	*
B	H	N	T	Z	*
C	I	O	U	*	TALK
D	J	P	V	FLN	SPAC
E	K	Q	W	*	BKSP
F	L	R	X	SPL	QUIT

Fig. 1. CRT display used in the mental prosthesis. The rows and columns of the matrix were flashed alternately. The letters selected by the subject ('B-R-A-I-N') were displayed at the top of the screen in the pilot study.

Figure 1.4 6x6 matrix of characters used by Farwell and Donchin in 1988 [13]

1.6 Brain Computer Interface Inputs

Brain computer interfaces use the brains signals at its input. However, there are different parts of the EEG that it can use. BCI systems commonly use four different aspects of the EEG signal: 1) visual-evoked potentials, 2) slow cortical potentials, 3) mu and beta rhythms, and 4) the P300 component of Event-Related Potentials [17]. Only the P300 component of the ERP is used in this research, therefore it will be the only one that

will be explained in depth. Event-related potentials are the recorded EEG changes in response to an internal cognitive event [18]. The ERP can be caused by a visual, auditory, or somatosensory stimulus. Figure 1.5 shows a recorded ERP with all its negative and positive peaks. This study, along with many others uses the P300 section of the ERP.

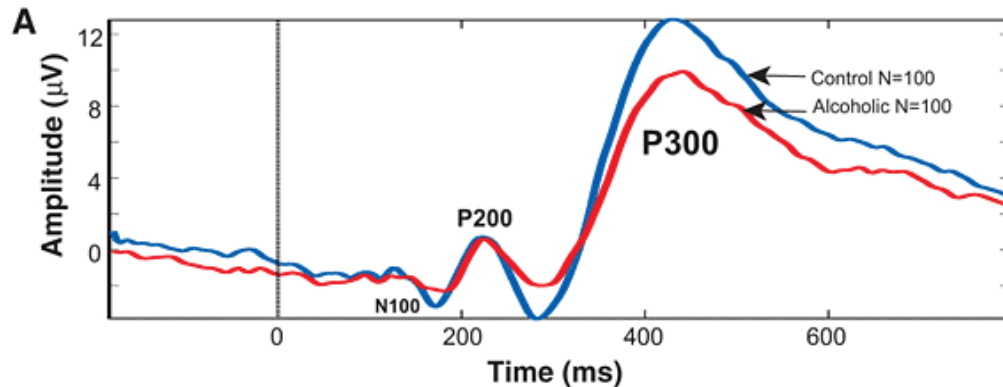

Figure 1.5 ERP at electrode location Cz to the visual oddball target processing. The curves show the P300, P200, N100, and N200 [19]

The oddball paradigm is where the subject's attention is directed to a rarely presented 'target' stimulus, while their EEG response to unexpectedly occurring 'novel' stimuli is investigated [20].

1.7 BCI Paradigm Design

There are a couple of different paradigms that are used for BCI spelling purposes. The original paradigm being the row/column (RC) developed by Farwell and Donchin in 1988 [13]. Similar to the RC paradigm are the single character (SC) and the checkerboard paradigm (CB) [21]. The region based paradigm (RB) is another type that has been developed [22]. In the following sections, different paradigms are explained in more details.

1.8 Row/Column Paradigm

Farwell and Donchin introduced this paradigm in 1988 as shown in Figure 1.4 [13]. It is a 6x6 matrix of alphanumeric characters that flash by rows and columns. When the rows and columns flash the subject is focusing on the “target” row and column, when they flash that produces a P300 signal which the computer detects [13]. The character is then selected by the intersection of the row and column with the most P300s generated. Figure 1.6 shows how the original FD paradigm has changed slightly to eliminate the computer commands and only use alphanumeric characters.

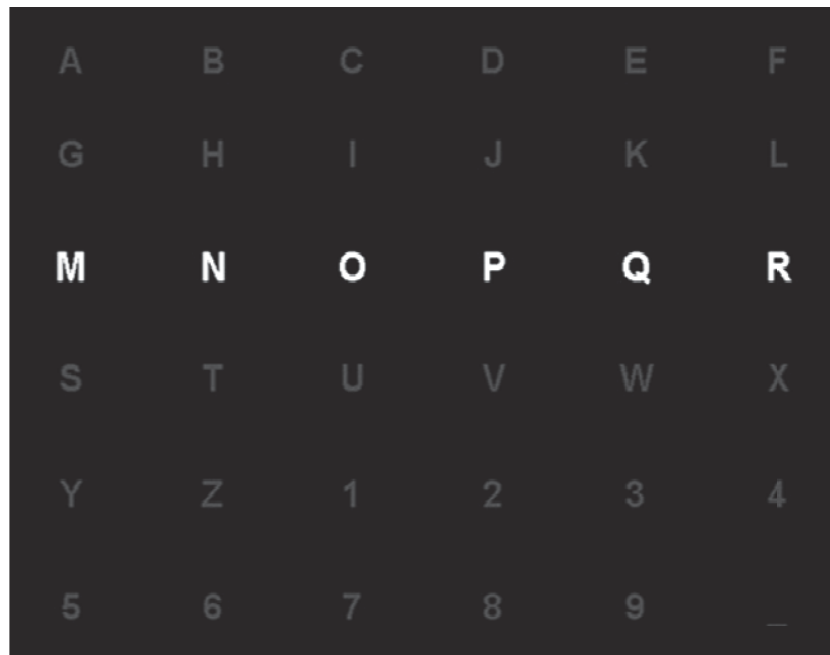

Figure 1.6 Row/Column paradigm introduced by Farwell and Donchin in 1988 [13]

Since the P300 is a low amplitude signal this paradigm requires multiple flashes to ensure the target character gets selected [17].

1.9 Single Character Paradigm

The single character paradigm is the exact same as the RC with only one difference, instead of rows and columns flashing one character flashes at a time. This paradigm due to the slow speed has a low user acceptability and high usage difficulty compared to the RC, RB1, and RB2 paradigms [23]. In 2009 Guger compared both the SC and RC paradigms and the results show that 55.3% (N=38) were able to spell 100% accurate using the SC paradigm while 72.3% (N=81) were able to spell 100% using the RC paradigm. Less than 3% were not able to spell any character correctly [14].

1.10 Region Based Paradigms

The region-based paradigm was introduced for the first time in 2007 [24]. There are two versions of the region based paradigm, one with the characters in alphabetical order and another one with the characters in order of most frequently used characters in the English language [25]. Table 1.2 shows the characters that are used in both the RB1 and RB2 paradigms.

	Region Based 1	Region Based 2
Region 1	ABCDEFGH	ETAONRI
Region 2	IJKLMNOP	SHDLFCM
Region 3	OPQRSTU	UGYPWBV
Region 4	VWXYZ12	KXJQZ12
Region 5	3456789	3456789
Region 6	0/*-+.?&	0/*-+.?&
Region 7	“!@#%&”	“!@#%&”

Table 1.2 List of characters in level 1 in RB1 and RB2

Similar to the flashing of the row and column each cluster of characters flashes randomly until one gets selected and then those seven characters get distributed similar to the regions. Figure 1.7 shows the distribution of characters from level 1 to level 2 [23].

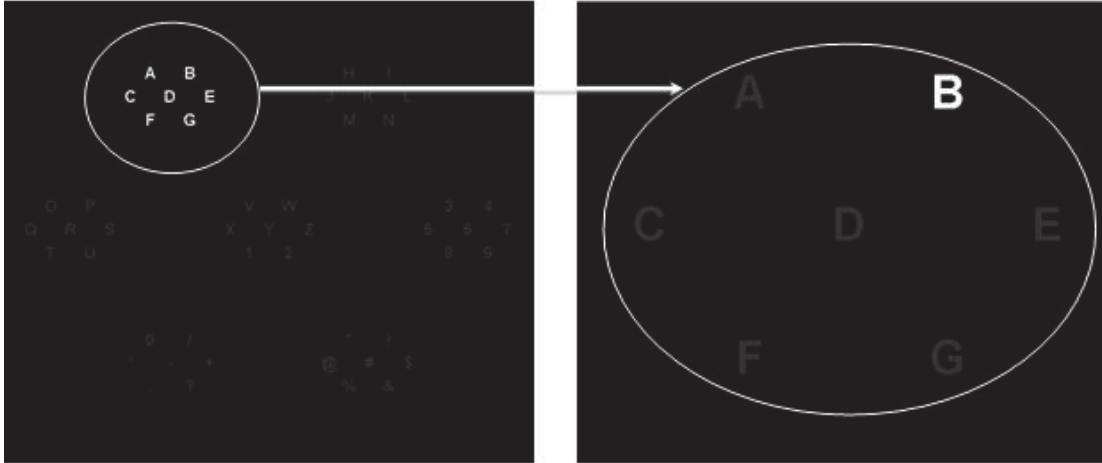

Figure 1.7 (left) RB1 at the first level where region 1 is selected, (right) RB1 paradigm at the second level where the seven characters in this region are expanded on the screen [23]

Not only is there an increase of characters from 36 to 49 compared to the RC and SC paradigms, this RB paradigm reduces the crowding effect and eliminates the adjacency problem [23,25]. Crowding effect and the adjacency problem are both described in section 1.15.

1.11 Checkerboard Paradigm

The checkerboard paradigm eliminates the adjacency problem and the double flash problem but does not do away with the crowding effect. The CB works by randomly creating two 6x6 matrices with alphanumeric characters and superimposing them together to create an 8x9 matrix shown in Figure 1.8 [21]. The paradigm avoids the double flash problem by always randomly filling the two matrices and flashing the virtual rows and columns. What the subject sees are six random characters flashing; this fixes the adjacency problem as well.

A	B	C	D	E	F	G	H
I	J	K	L	M	N	O	P
Q	R	S	T	U	V	W	X
Y	Z	Sp	1	2	3	4	5
6	7	8	9	0	.	Ret	Bs
?	,	;	\	/	+	-	Alt
Ctrl	=	Del	Home	UpAw	End	PgUp	Shift
Save	'	F2	LfAw	DnAw	RtAw	PgDn	Pause
Caps	F5	Tab	EC	Esc	email	!	Sleep

Figure 1.8 CB paradigm with the two 6x6 matrices superimposed [21]

WADSWORTH (W)							
A	B	C	D	E	F	G	H
I	J	K	L	M	N	O	P
Q	R	S	T	U	V	W	X
Y	Z	Sp	1	2	3	4	5
6	7	8	9	0	.	Ret	Bs
?	,	;	\	/	+	-	Alt
Ctrl	=	Del	Home	UpAw	End	PgUp	Shft
Save	'	F2	LfAw	DnAw	RtAw	PgDn	Pause
Caps	F5	Tab	EC	Esc	email	F11	Sleep

Figure 1.9 CB paradigm flashing 6 random characters [21]

Figure 1.10 shows the two 6x6 matrix that are randomly selected to flash each row and column to ensure at least 6 flashes before the target character can flash again.

2	Bs	Shift	H	Sp	EC
l	R	Y	7	?	=
Save	F5	M	F2	9	;
B	K	PgDn	End	email	-
V	F	Home	.	D	4
O	T	X	Sleep	/	DnAw
Tab	Del	8	C	1	E
Del	0	W	3	Ctrl	Z
Q	J	S	L	,	U
5	G	N	P	A	+
LfAw	'	Esc	6	PgUp	Caps
UpAw	Pause	Alt	\	l	RtAw

Figure 1.10 CB two 6x6 matrices that are randomly selected [21]

Table 1.3 shows the selection per minutes and bit rates for the row/column and the checkerboard paradigms based the results reported in [17].

Participant	RC (sel/min)	CB (sel/min)	RC bit rate	CB bit rate
1	4.28	3.86	26.38	23.80
2	0.45	3.07	2.76	18.94
3	5.16	5.02	31.82	31.00
4	1.79	3.07	11.07	18.94
5	1.79	3.56	11.07	21.94
6	4.50	3.40	27.79	20.98
7	4.77	4.31	29.44	26.62
8	3.97	3.07	24.50	18.94
9	0.00	2.61	0.00	16.11
10	0.00	3.69	0.00	22.75
11	1.58	3.28	9.77	20.21
12	1.12	4.92	6.91	30.34
13	0.00	2.80	0.00	17.27
14	5.04	6.38	31.09	39.35
15	4.24	4.31	26.15	26.62
16	3.15	2.05	19.40	12.68
17	3.71	4.07	22.86	25.10
18	2.92	2.42	18.01	14.95
Mean	2.69	3.66	16.61	22.59

Table 1.3 Selections per minute and practical bit rates of RC and CB with taking error correction into account [21]

1.12 Signal Processing and Classifier Training

Pre-processing is an important step in brain computer interface since the amplitude of the signal is very low and it being very prone to noise. The signal is usually put through a bandpass filter to remove the dc component and any high frequency that is unwanted [25].

There are many different classification methods used with P300 based brain computer interfaces [25]. Linear discriminant analysis, support vector machines, and stepwise linear discriminant analysis will be discussed in following sections.

1.12.1 Linear Discriminant Analysis

Linear Discriminant Analysis (LDA) is a machine learning technique; its objective is to find the best grouping of features that separate two types of events [26].

LDA is a superior classification technique for detection of P300 signals in BCI than support vector machines [27]. There are a few difference variances of LDA including Fisher linear discriminant analysis, stepwise linear discriminant analysis, and Bayesian linear discriminant analysis [25].

1.12.2 Support Vector Machines

Support Vector Machines (SVM) offers an effective approach for pattern recognition in high-dimensional problems [28]. This machine learning technique is frequently used for binary classification purposes [25].

1.12.3 Stepwise Linear Discriminant Analysis

Farwell and Donchin used stepwise linear discriminant analysis for their original 6x6 matrix paradigm P300 brain computer interface virtual speller [13]. Stepwise LDA is an extension of LDA where only suited features are selected for the discriminant analysis therefore reducing the number of features required for classification [25].

1.13 Row/Column Paradigm Visual Modifications

Ever since the original 6x6 matrix paradigm was introduced in 1988, there have been many visual modifications done to it. A study done by Salvaris and Sepulveda was conducted not to achieve the highest possible accuracy, but to determine whether these straightforward modifications to the visual protocol will provide classification differences between them and what those differences might be [16]. The study consisted of 8 subjects performing 6 experiments each of which they spelt out the phrase “THE_QUICK-BROWN_FOX_JUMPS_OVER_LAZY_DOG”, this phrase was chosen since it uses every letter in the English alphabet [16]. The 6 experiments were to test the

differences between a black background versus a white background, large symbol size versus small symbol size, and large inter-symbol distance versus small inter-symbol distance [16]. The following three figures show the six experiments visual paradigms.



Figure 1.11 White and black background visual paradigms [16]

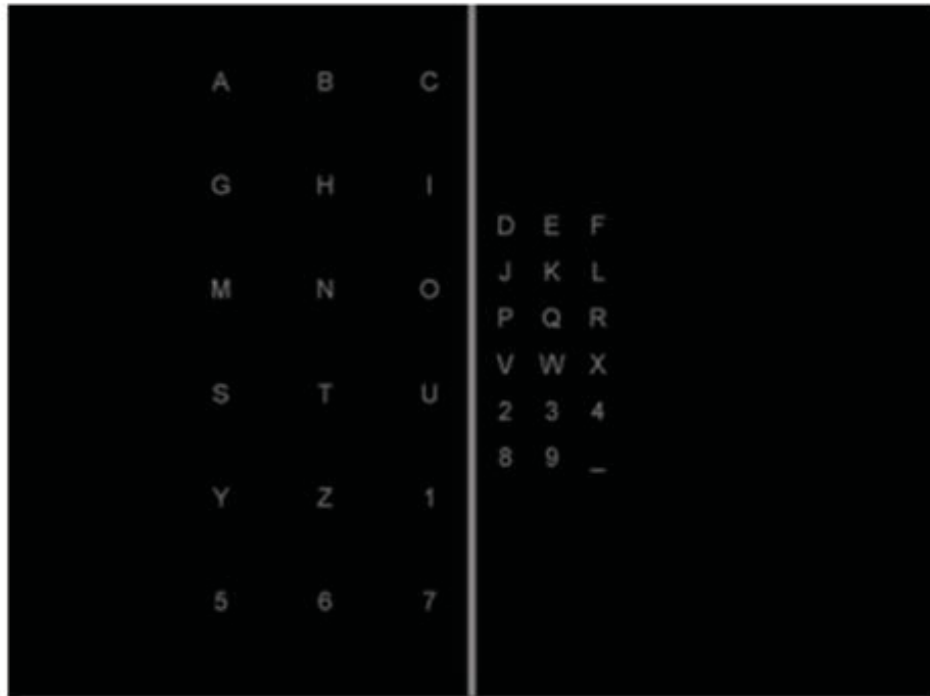

Figure 1.12 Large and small inter symbol distance visual paradigm [16]



Figure 1.13 Large and small symbol size visual paradigm [16]

The six experiments were done with two different classifications to determine if the results were classifier independent. The two classifiers were support vector machine

(SVM) with a radial basis function (RBF) kernel and Fisher's linear discriminant (FLD) [16]. The results of the study showed that the only visual change that was statistically different was the white background and small symbol size; also there were no dependency for either classifier [16].

1.14 Challenges in P300 Brain Computer Interface

There are many challenges that brain computer interfaces face. Low amplitude of the EEG signals measured from the scalp even with conductive gel only generate between 10-100 μV . With that in mind the more electrodes that are being used the better chances of P300 signals that can be detected. The problem with a lot of electrodes is the amount of time it takes to set everything up. Calibration is another downfall but a necessary step in the BCI process, being that it can take between 20-40 minutes [29]. EEG signals are very sensitive and can be affected by the involuntary actions such as blinking. Figure 1.14 shows the effects of blinking to the EEG signal, circled in red are a few of the peaks that are cause by blinking.

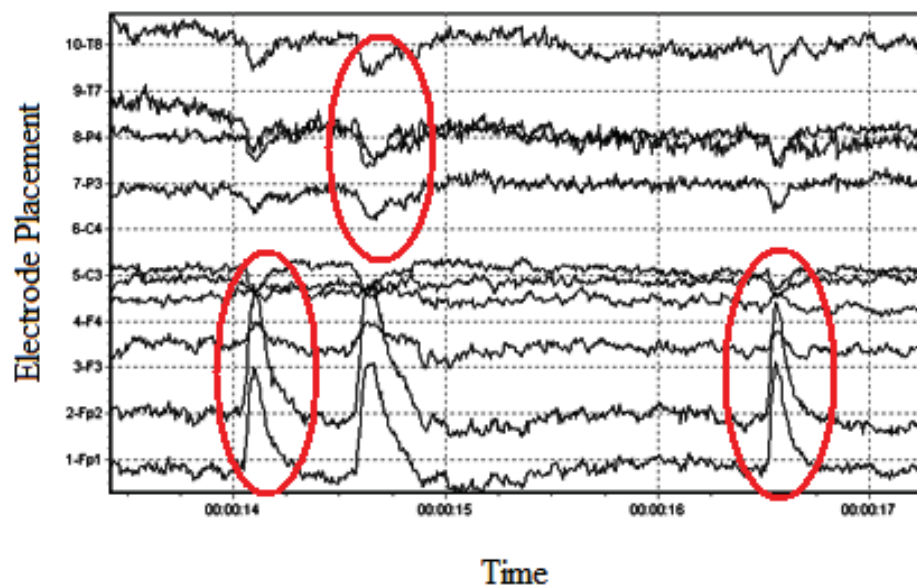

Figure 1.14 EEG with blinking artifacts [30]

For speller applications there are specific challenges for each paradigm. The original FD paradigm has crowding effect, adjacency problems, and repetition blindness.

1.15 Crowding Effect and Adjacency Problem

The crowding effect is the difficulty to visually discriminant the target character due to similar characters surrounding it [25,31]. The 6x6 matrix paradigm is prone to this effect due to the large number of surrounding characters of any given target character. Depending on the location of the target character there can be three to eight surrounding characters. Figure 1.15 shows the error distribution for the RC paradigm, most of the errors are adjacent to the target character due to the crowding effect and the adjacency problem.

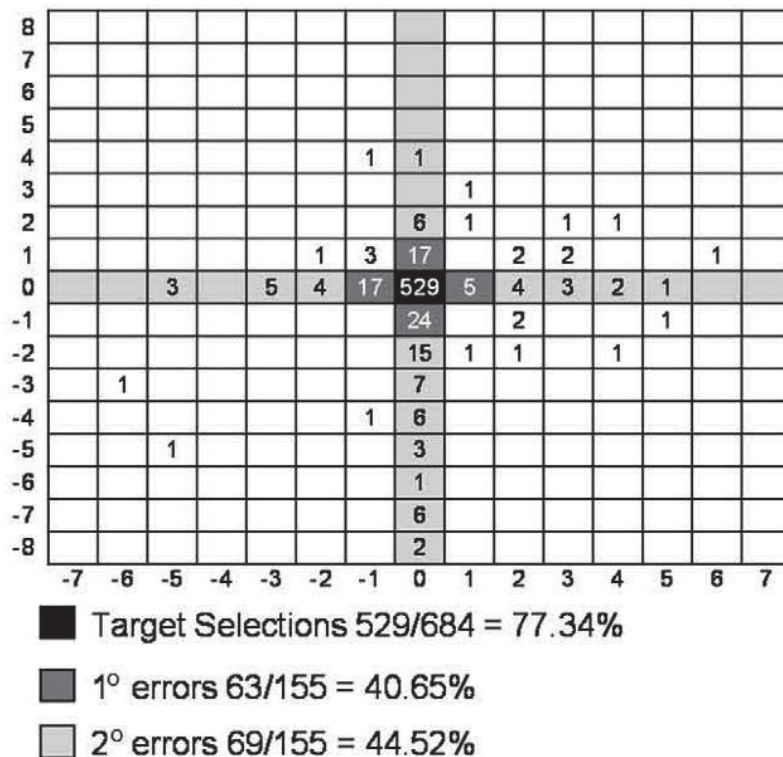

Figure 1.15 Error distribution for the RC paradigm [21]

The adjacency problem is due to the neighboring characters flashing the subject noticing and having it generate a P300 [21,24-25]. This problem can be eliminated by reducing the flashes of non-target characters adjacent to the intended character. A new checkerboard paradigm was introduced in 2010 to eliminate this problem. The CB paradigm was discussed in section 1.11. Figure 1.16 shows the error distribution using the checkerboard paradigm. There are fewer errors adjacent to the target character as compared to the RC paradigm shown in Figure 1.15.

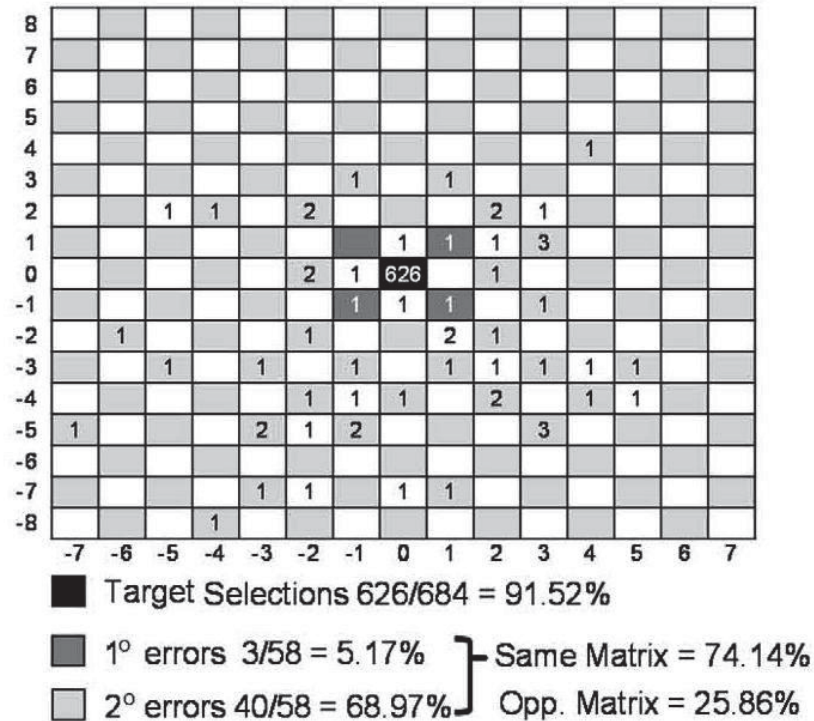

Figure 1.16 Error distribution for the CB paradigm [21]

1.16 Double Flash

Double flash is caused when the target character is flashed and then immediately flashed again. This can cause the second flash to go unnoticed by the subject lowering the number of P300's the intended character should get. If the flash is noticed the two P300 signals could be overlapped and reduce the amplitude of the P300 [21].

1.17 Applications of P300 Brain Computer Interface

There are many different applications that have to deal with the interaction of the brain and a computer. In this section we will discuss a few of them that deal primarily with the P300 signal.

1.18 Lie Detector

There have been experiments to show that the EEG waves are different when a person has prior knowledge of a crime or other knowledge [32]. In 1995 Farwell came up with an experiment to show that the P300 signal is reduced when a subject is shown something he/she has prior knowledge to [33]. Subjects were shown three different stimuli's 1) 'target', 2) 'probes', and 3) 'irrelevant'. The 'probes' stimulus was the one that would produce a large P300. Half of the subjects were involved in a mock crime while the other half was not [33]. The results are shown visually below.

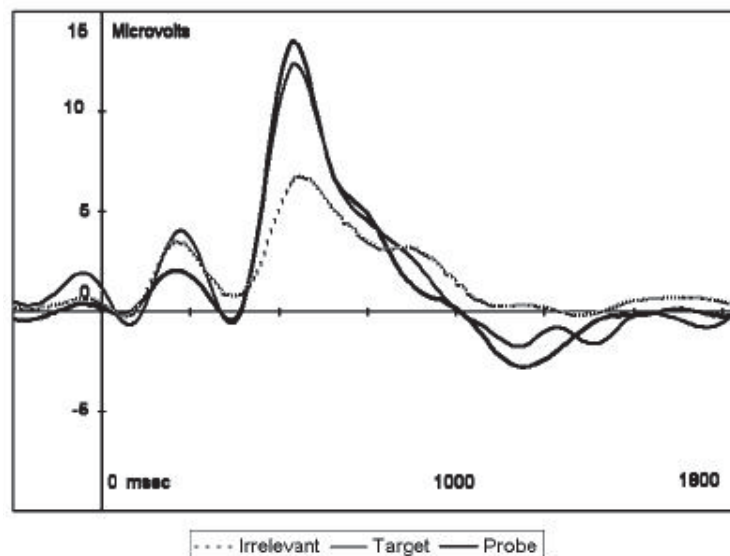

Figure 1.17 EEG data for a subject who is knowledgeable regarding the investigated event [33]

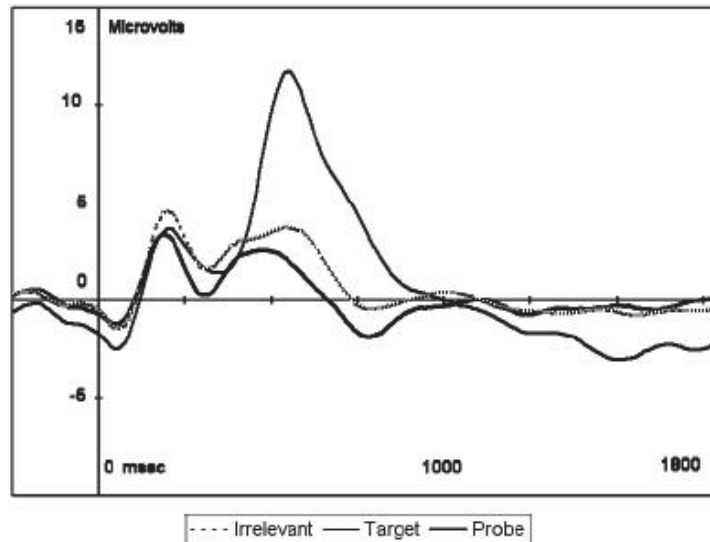

Figure 1.18 EEG data for a subject who is not knowledgeable regarding the investigated event [33]

1.19 Virtual Speller

Farwell and Donchin were the first to introduce a virtual speller in 1988 [13]. Since then there have been many other paradigms and modifications to them. The checkerboard, region based, and single character are all variations of the original paradigm. Virtual spellers are very useful for people with amyotrophic lateral sclerosis (ALS), multiple sclerosis (MS), locked in syndrome, and other diseases or injuries. Recently there has been a lot of research in the P300 based brain computer interface virtual speller devices [25].

1.20 Smart Home

Guger set up a P300 based BCI experiment to test a virtual smart house. He had the subjects perform tasks such as switching on and off the lights, opening and closing the doors and windows, controlling the TV set, using the phone, playing music, operating a video camera at the entrance, walking around in the house, and moving him/herself to a specific location in the smart home [34]. Figure 1.19 shows the control mask with the

main menu in the first 2 rows, the icons for the camera, door control and questions in the 3rd and 4th row and the TV control in the last 2 rows and the control mask for going to a specific position in the smart home.

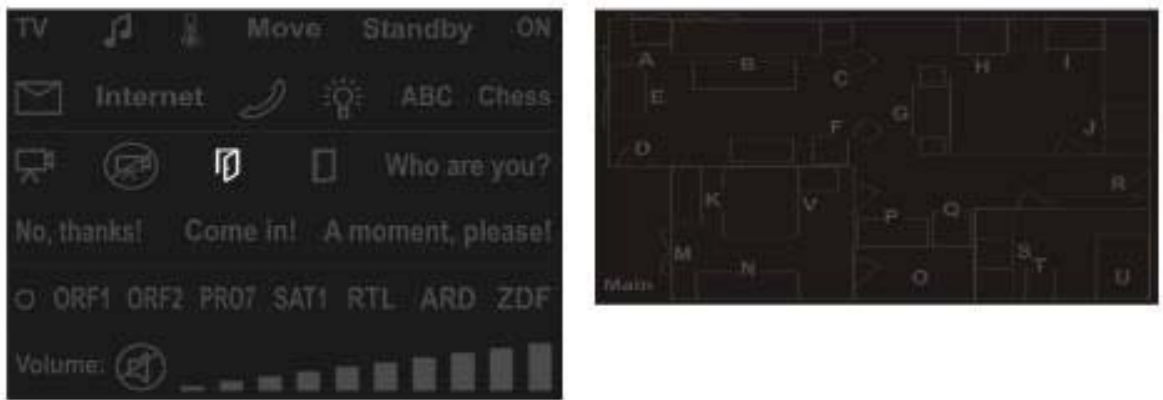

Figure 1.19 (left) Control mask with the main menu in the first 2 rows, the icons for the camera, door control and questions in the 3rd and 4th row and the TV control in the last 2 rows. (right) Control mask for going to a specific position in the smart home. The mask gives a bird's eye view of the apartment with characters at specific positions [34]

Chapter 2. Methods and Materials

2.1 Experiments

For this thesis there were three experiments performed. An initial one comparing the SC, RC, RB1, and RB2 paradigms, one to explore the errors of the different regions for the region based paradigms, and the comparison of the SC, RC, and RB2 paradigms for 23 subjects. Products of Guger Technologies (g.tec) were used, including g.GAMMAbox and g.USBamp for recording and g.BSanalysis for classification. MATLAB and Simulink were used for the paradigms on the computer.

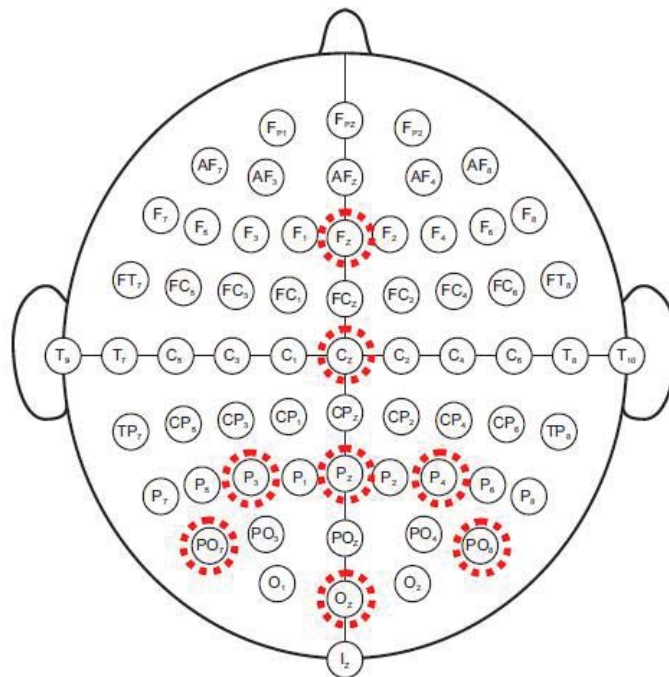

Figure 2.1 Electrode location using the based on the international 10-20 system [35]

EEG signals were recorded from eight channels at FZ, CZ, PZ, OZ, P3, P4, PO7, and PO8 locations as shown in Figure 2.1. These locations are based off the international 10-20 electrode system of electrode placement. The 10-20 electrode cap is named due to the spacing of the electrodes, 10 and 20 degrees respectively [36]. An electrode at the FPZ location was considered as a ground channel and one electrode on the right mastoid was considered as a reference channel. Data were sampled with a frequency of 256 Hz and filtered by a 0.1 Hz high pass, a 30 Hz low pass. Six flashes with a flash time of 100 ms and a blank time of 150 ms were considered. Linear discriminant analysis was used for the classification.

2.2 Ethical Approval

Ethical approval was obtained from the Institutional Review Board (IRB) from the University of North Dakota (UND). The IRB is responsible for ensuring that the rights and welfare of human subjects in social behavioral and biomedical research are protected [37]. For our testing our IRB approval number was IRB-201006-372. Every person carrying out the tests has gone through ethical training provided by the IRB.

2.3 Equipment

For these experiments we used products of Guger Technologies (g.tec). The g.GAMMAbox and g.USBamp are used for recording and g.BSanalysis for classification. We use 8 of the g.LADYbird electrodes located at the FZ, CZ, PZ, OZ, P3, P4, PO7, and PO8 locations according to the international 10-20 system [35]. In addition to the eight electrodes we are using the g.LADYbirdGND for the ground location at FPZ location.



Figure 2.2 (top left) g.GAMMAbox, (top right) g.GAMMAusb, (bottom left) g.GAMMAearclip, (bottom middle) g.LADYbird, (bottom right) g.LADYbirdGND

For the reference we are using the g.GAMMAearclip also from g.tec medical engineering. All of these electrodes are held in place using the g.GAMMAcap as shown in Figure 2.3.



Figure 2.3 g.GAMMAcap product of g.tec

2.4 Test and Paradigms

The paradigms in this experiment were preformed in a random order using the MATLAB operation `randperm(x)` where `x` was the number of paradigms being tested. The subject was seated in front of the computer and the g.GAMMAcap was placed on their head. The tester applied first an abrasive gel to move the hair from the electrode and remove any dead skin on the scalp shown in figure 2.4. Then a conductive gel is applied to help the electrodes pick up the EEG signal from the brain through the scalp. Once the calibration is complete and the LDA classification is loaded the test administrators opens the paradigm in MATLAB and types in the word the subject is going to try and copy spell. The subject then focuses on the target character and attempts to spell the string of characters correctly. For the SC paradigm the subject is instructed to focus on the target character and is told to keep a mental count of how many times that target character is flashed. The subject should be counting to six every time.



Figure 2.4 (left) The abrasive gel (right) the conductive gel

Once a character is selected then the subject will focus on the next target character until the copy spelling is complete. The SC paradigm takes the most amount of time compared to the other two paradigms as shown in Table 2.1. The second paradigm that was tested

is the RC which is very similar to the SC paradigm with the only difference being that instead of a single character being flashed and whole row or column would flash making this paradigm three times faster than the SC paradigm. The final paradigm that was tested was the RB2 paradigm. This is a region based paradigm where there 7 sets of 7 characters spread out as shown in Figure 1.7. The subjects are instructed to focus on the set of characters that contains the target character or also known as the target set of characters. Once the set of characters is selected the 7 characters are distributed similar to the layout of the sets of characters then the subject can focus on the target characters as they randomly flash. Like the other two paradigms the subject is also asked to keep a mental count of the number of times the target character or set flashes.

Paradigm	Time (s)
SC	54
RC	18
RB	21

Table 2.1 Amount of time required to spell one character per paradigm

The amount of time it takes to spell out one character is based on the flash time, the dark time, and the number of flashes, Table 2.1 shows the amount of time it takes to spell a character per paradigm.

2.5 Data Analysis and P300 Detection

The EEG signals that are being recorded for this experiment are saved into a .mat file that is specific to each subject. The name of each .mat file is in the following format: xxx-x-x.mat, where the first three characters are the subject id, the fourth character is the paradigm number, and the final character is the trial number of the set of words for that paradigm. The signal processing part of the program will truncate the beginning and

ending part of the EEG signal after the stimulus. This is done so the peak should fall into the range and the computer can determine which character elicited the most and largest P300s. Figure 2.5 shows the P300 signal in the EEG from Subject 4. The red line in the graph represents when the target character flashed. The RC paradigm selects the correct character by which row and column have the largest and most P300s then takes the intersection of these two to show the probable target the subject was focusing on.

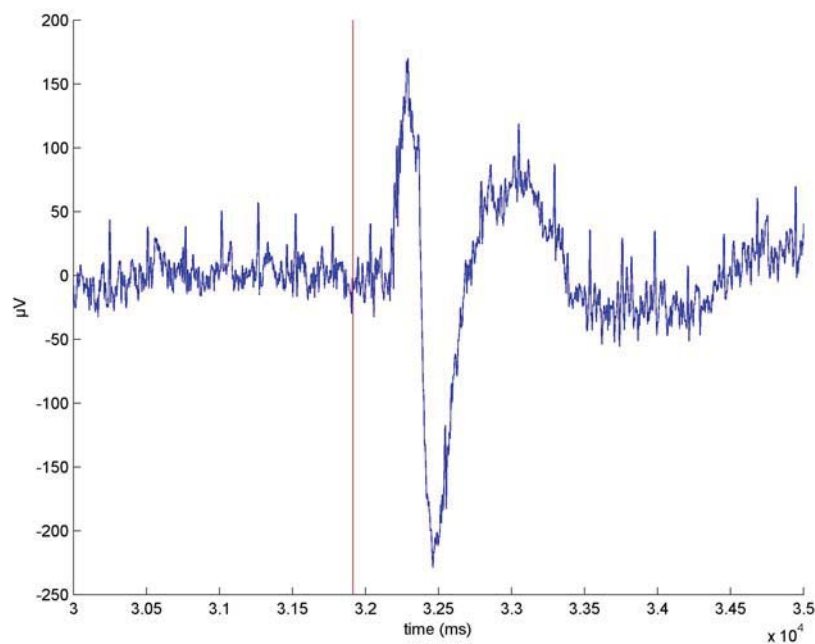

Figure 2.5 EEG from Subject 4 showing a P300

The SC paradigm just takes the single character that has the largest and most P300s. Similar to the SC, the RB2 selects the region that has the largest and most P300s, it does this twice until it selects a character.

2.6 Questionnaire

There are two questionnaires that each subject fills out in order to be able to determine their mood, fatigue level, and other feelings on the paradigms. The subject fills out the first half of the Brain Computer Interface Subject Questionnaire shown in Appendix A – BCI Subject Questionnaire before any testing. After each paradigm is complete the subject would then fill out a separate questionnaire to evaluate only that paradigm, this questionnaire can be seen in Appendix B – Subject Questionnaire. Once the entire experiment is over then the subject will complete the second half of the Brain Computer Interface Subject Questionnaire. The questionnaires are eventually compiled to determine which paradigm causes the most fatigue and which are the most user friendly.

Chapter 3. Results and Discussion

3.1 Experiments

For this thesis there were three experiments that took place and are going to be discussed in this section. The first experiment was implemented in July of 2010 and was the comparison of the SC, RC, RB1, and RB2 paradigms. Only six subjects were tested for this experiment. The second experiment was to test the errors per region for the RB paradigms and took place in late 2010 and only 8 subjects were considered. The final experiment was the comparison of the SC, RC, and RB2 paradigm which took place in the first half of 2012 and 23 subjects were considered. The results of each experiment are described in greater detail in the following sections.

3.2 Comparison of SC, RC, RB1, and RB2

In this experiment four different paradigms were used: row/column (RC), single character (SC), region based 1 (RB1), and region based 2 (RB2). Spelling two words, 'WATER' and 'LUCAS', test each word three times for each paradigm. Each subject underwent a calibration using the RC paradigms spelling the word, 'WATER', depending on the subject they would spell the word 2-4 times.

3.2.1 Subjects

Six subjects (6 Males) ranging in age from 22-29 with the average age being 25.83 years. Every subject had/has some affiliation with the University of North Dakota. Each subject voluntarily participated in the experiments which lasted about 2-2.5 hours on average per subject. Each subject was explained the procedure, asked to read and sign

the consent form for the IRB approval, seated in front of a computer screen, and was told to relax and avoid any unnecessary movements during testing.

3.2.2 Accuracies of Paradigms

The two graphs below show the results of the accuracies of spelling the two words. Looking at the graphs it is clear that the SC paradigm had the lowest percent correct. While, not as obvious the RB2 and RB1 outperformed RC.

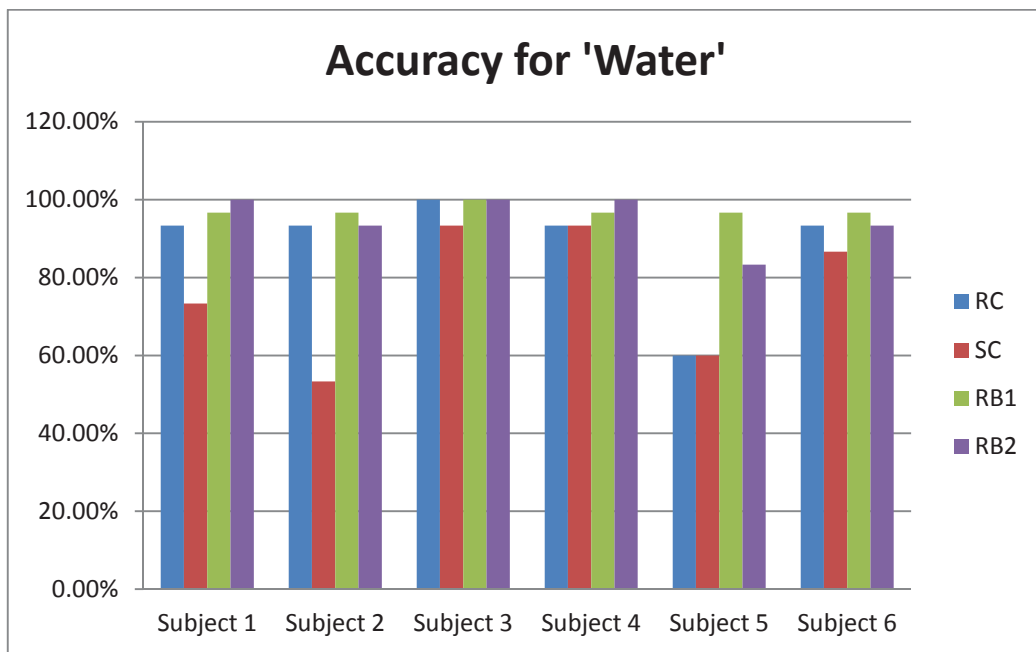

Figure 3.1 Accuracy for the word 'WATER' for each subject and each paradigm [23]

The average accuracies for each paradigm were 72.2%, 85%, 90.6%, and 86.1% for the SC, RC, RB1, and RB2 paradigms respectively. The bit rates for each paradigm were 11.1, 15.8, 17.4, and 16.2 for the SC, RC, RB1, and RB2 paradigms respectively using the equation 3.1.

$$B = \log_2 N + P \log_2 P + (1 - P) \log_2 \left[\frac{1-P}{N-1} \right] \quad (3.1)$$

The amount of time in seconds it took to select one character was 11.52, 34.56, 13.44, and 13.44 seconds for the RC, SC, RB1, and RB2 paradigms respectively

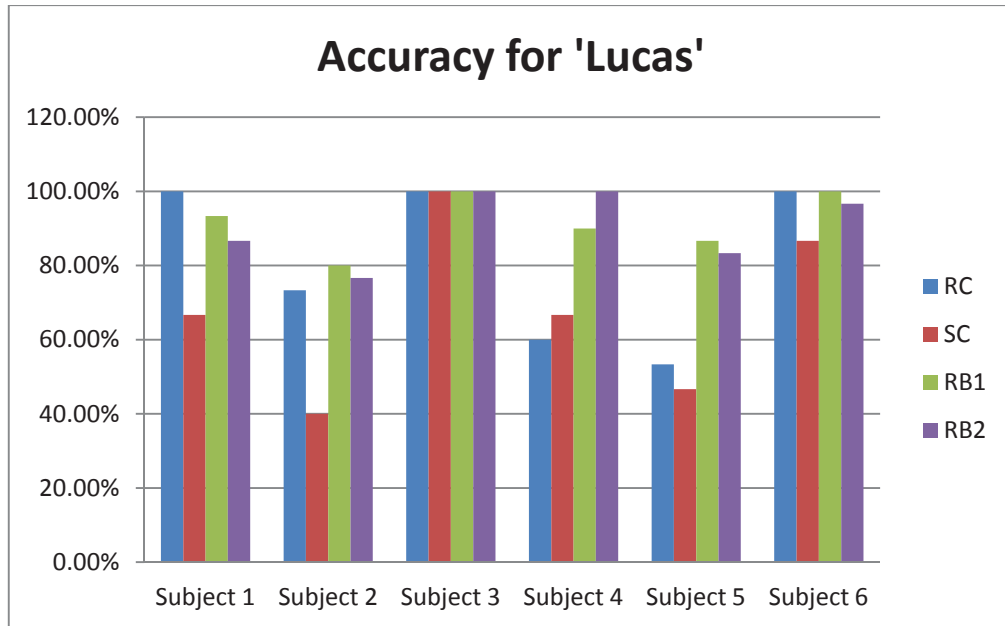

Figure 3.2 Accuracy for the word 'LUCAS' for each subject and each paradigm [23]

For the questionnaire results the level of fatigue was 6, 7.8, 5.1 and 6.7 for RC, SC, RB1, and RB2 paradigms respectively. The user acceptability was 7, 5, 7.5, and 7.8 for RC, SC, RB1, and RB2 paradigms respectively. The usage difficulty was 3, 5, 2.5, and 1.8, for RC, SC, RB1, and RB2 paradigms respectively [23].

3.2.3 Region Errors

For the same test we determined the errors per region for the six subjects. Figure 3.3 shows the errors per region for the RB1 and RB2 for the all three trials. Region four shows the most errors and with such a small sample size there needs to be another test designed to test this with more subjects.

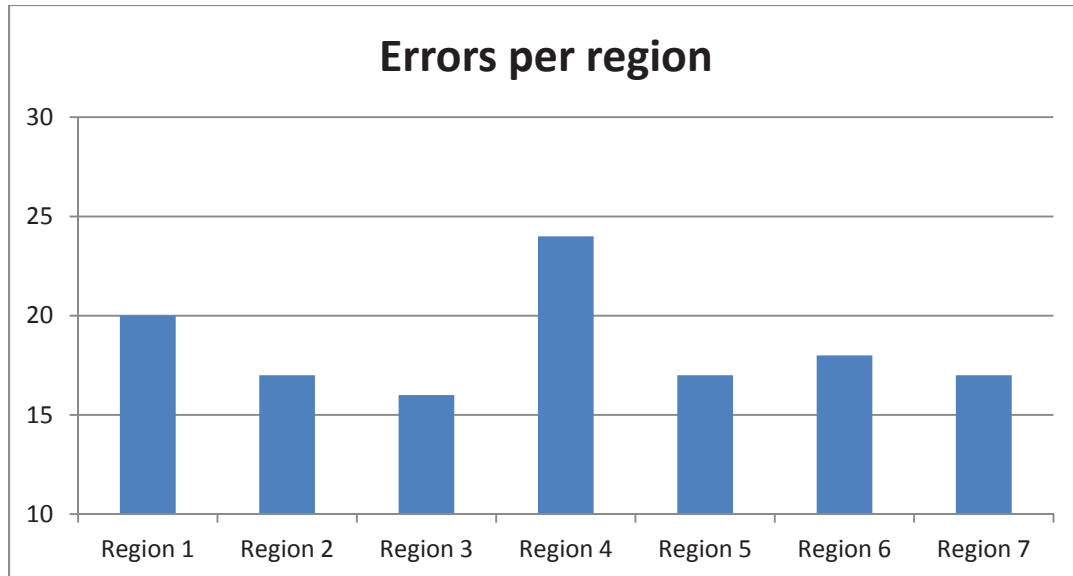

Figure 3.3 Errors per region results from a study in 2010 [23]

3.3 Errors per Region in an RB Paradigm

This experiment was designed to test the errors per region for a region based paradigm. Each region was filled with the same characters ‘ABCDEFG’ so there would be no errors due to difference in characters. There were 8 subjects (8 males) that participated in the experiment ranging in age from 19-27 with an average age of 22.00 years. Twenty random trials were performed with these eight subjects. During the region selection process, each subject was asked to select all regions in a given random order and errors were recorded. An error was considered when a wrong selection was made by the user as opposed to the intended region. It was found that the region 4 (in the middle of screen) had the lowest accuracy (maximum error) among the seven regions. All surrounding regions (regions 1-3 and regions 5-7) had similar accuracies and higher accuracy than region 4. The graph on the next page shows the average errors per region for the 8 subjects.

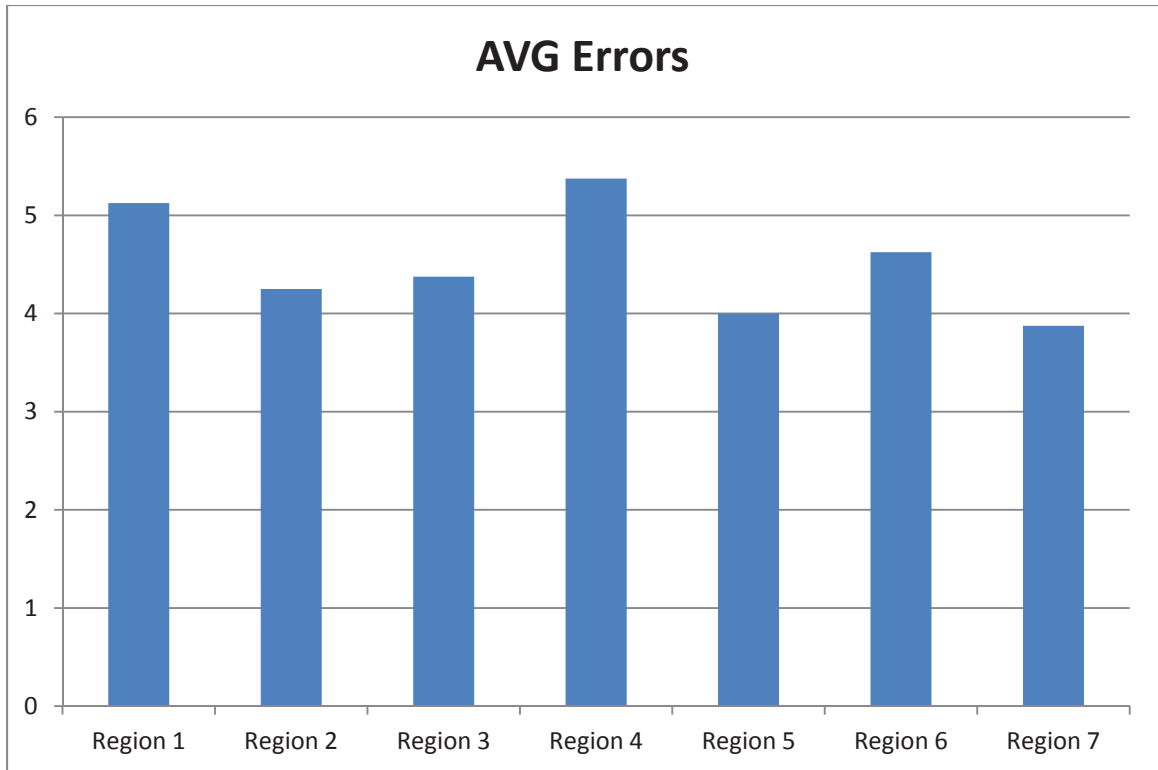

Figure 3.4 Average errors per region for the errors per region experiment

3.4 Comparison of SC, RC, and RB2

In this experiment we used three different paradigms row/column (RC), single character (SC), and region based 2 (RB2). Spelling two words, ‘PEBBLE!’ and ‘MX85+Z&’, testing each word three times for each paradigm. Each subject underwent a calibration of spelling two words, ‘WATER’ and ‘LUCAS’, using the RC paradigm, each word was spelt three times. The two words used for the testing were selected because each region in RB2 gets selected exactly four times each. The placement of the extra characters in the 6x6 matrix were selected for a similar reason, to even out the number of times a row or column would be selected.

3.4.1 Subjects

Twenty-three subjects (17 Males, 6 Females) ranging in age from 19-29 with the average age being 22.78 years. Every subject had/has some affiliation with the University of North Dakota. Each subject voluntarily participated in our experiments which lasted about 2-2.5 hours on average per subject. Each subject was explained the procedure, asked to read and sign the consent form for the IRB approval, seated in front of a computer screen, and was told to relax and avoid any unnecessary movements during testing.



Figure 3.5 Modified 6x6 matrix for this experiment

3.4.2 Accuracies of Paradigms

There are many different ways to analyze the results from this experiment. This section is going to focus on the percentage of correct characters selected for each paradigm. There are a few subjects that had very low percentages and those will be

removed to show how those outliers affect the overall results. According to a study done in 2009 by Guger et al. they showed about 3% of subjects tested (N=100) were not able to spell any characters correctly [14]. The individual results of all the subjects are shown in Appendix E – Results from the comparison of SC, RC, and RB2 Paradigms. Table 3.1 on the next page shows the average of three trials for each subject for each word. The table shows that while RC and RB2 paradigms were similar in accuracies with 71.58% and 74.11% respectively for both words for all subjects. The SC paradigm did not do as well with an average of 54.15% for all subjects for both words. There was a two way analysis of variance (ANOVA) test done to see if there were any statistical evidence for one of the paradigms being better than the other two or two better than one. Minitab was used with the average of the three trials for each subject and each word (i.e. there were 23 subjects * 3 trials = 69 accuracy points for the word PEBBLE! and 69 accuracy points for the word MX85+Z&). In addition to the ANOVA test there was a main effects plot for the accuracy shown in Figure 3.6 which shows the accuracy for each paradigm and both of the words. Figure 3.5 shows the matrix of characters used for the SC and RC paradigms in this experiment.

	PEBBLE!		
	SC-AVG	RC-AVG	RB-AVG
Subject 1	85.67	85.67	81.00
Subject 2	52.33	85.67	71.00
Subject 3	47.33	85.67	90.67
Subject 4	33.33	66.33	47.67
Subject 5	100.00	90.33	100.00
Subject 6	38.00	81.00	62.00
Subject 7	33.67	95.33	76.00
Subject 8	81.00	85.67	76.33
Subject 9	76.33	100.00	90.67
Subject 10	4.67	71.33	71.33
Subject 11	52.33	61.67	95.33
Subject 12	23.67	14.33	43.00
Subject 13	9.67	19.00	43.00
Subject 14	100.00	71.67	81.00
Subject 15	23.67	57.00	71.33
Subject 16	66.33	100.00	90.33
Subject 17	52.33	66.67	76.33
Subject 18	19.00	0.00	14.33
Subject 19	90.67	100.00	100.00
Subject 20	86.00	85.67	90.67
Subject 21	24.00	71.00	66.33
Subject 22	100.00	90.33	66.67
Subject 23	90.33	86.00	90.33
All Subjects	56.10	72.62	73.71

	MX85+Z&		
	SC-AVG	RC-AVG	RB-AVG
Subject 1	76.00	76.00	100.00
Subject 2	61.67	80.67	85.67
Subject 3	47.67	76.00	100.00
Subject 4	47.67	61.67	43.00
Subject 5	80.67	100.00	86.00
Subject 6	14.33	66.67	47.33
Subject 7	33.67	90.67	71.33
Subject 8	71.67	90.67	71.33
Subject 9	66.67	100.00	76.00
Subject 10	0.00	66.33	71.67
Subject 11	47.67	57.00	90.67
Subject 12	14.33	4.67	71.00
Subject 13	0.00	9.33	24.00
Subject 14	90.67	57.00	61.67
Subject 15	33.33	66.67	61.67
Subject 16	71.33	95.33	95.33
Subject 17	47.67	81.00	85.67
Subject 18	9.33	4.67	9.33
Subject 19	90.33	100.00	95.33
Subject 20	86.00	95.33	100.00
Subject 21	24.00	66.33	71.33
Subject 22	95.33	81.00	100.00
Subject 23	90.67	95.33	95.33
All Subjects	52.20	70.54	74.51

Table 3.1 Average accuracy of each paradigm for all subjects averaged for three trials

Below are the results from the two way ANOVA test and the post hoc Tukey testing results.

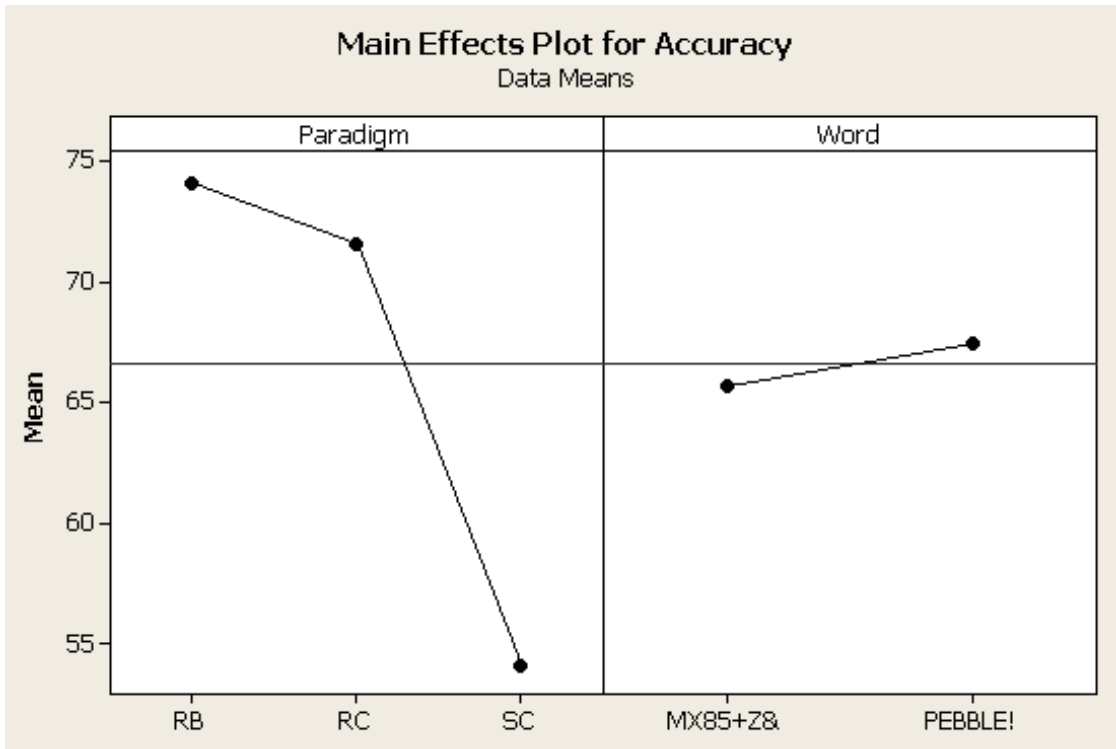

Figure 3.6 Accuracy by paradigm and by word

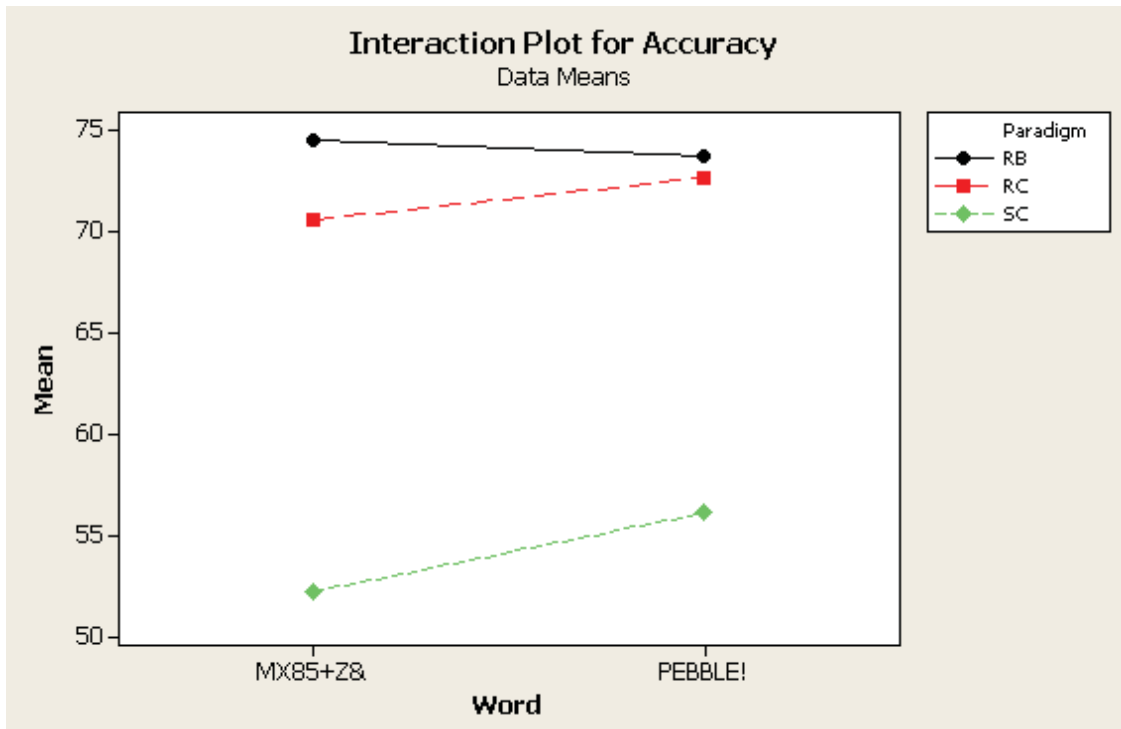

Figure 3.7 Interaction plot for Accuracy

Since the lines on the interaction plot above do not intersect, this means that there is no interaction between the two words. Therefore, the two words chosen have no negative effects on the accuracy results.

Two-way ANOVA: Accuracy versus Word, Paradigm

Source	DF	SS	MS	F	P
Word	1	103	103.15	0.13	0.715
Paradigm	2	10861	5430.69	7.05	0.001
Interaction	2	129	64.48	0.08	0.920
Error	132	101654	770.11		
Total	137	112747			

S = 27.75 R-Sq = 9.84% R-Sq(adj) = 6.42%
 Table 3.2 Two-way ANOVA test for all three paradigms

The two-way ANOVA results show that there is no interaction and there is no statistical evidence showing that the two different words make a difference when it comes to the accuracy. However, with the P-value of < 0.005 there is significant statistical evidence that there is a difference when it comes to paradigms for the accuracies. After the ANOVA testing the post hoc Tukey test was implemented. The results for this test are on the next page.

General Linear Model: Accuracy versus Paradigm

Factor	Type	Levels	Values
Paradigm	fixed	3	RB2, RC, SC

Analysis of Variance for Accuracy, using Adjusted SS for Tests

Source	DF	Seq SS	Adj SS	Adj MS	F	P
Paradigm	2	10861.4	10861.4	5430.7	7.20	0.001
Error	135	101886.0	101886.0	754.7		
Total	137	112747.4				

S = 27.4720 R-Sq = 9.63% R-Sq(adj) = 8.29%

Term	Coef	SE Coef	T	P
Constant	66.614	2.339	28.48	0.000
Paradigm				
RB2	7.495	3.307	2.27	0.025
RC	4.966	3.307	1.50	0.136

Unusual Observations for Accuracy

Obs	Accuracy	Fit	SE Fit	Residual	St Resid
58	14.330	71.580	4.051	-57.250	-2.11 R
64	0.000	71.580	4.051	-71.580	-2.63 R
81	4.670	71.580	4.051	-66.910	-2.46 R
82	9.330	71.580	4.051	-62.250	-2.29 R
87	4.670	71.580	4.051	-66.910	-2.46 R
110	14.330	74.108	4.051	-59.778	-2.20 R
133	9.330	74.108	4.051	-64.778	-2.38 R

R denotes an observation with a large standardized residual.

Table 3.3 Post hoc Tukey test for all three paradigms

The Tukey test shows that there is a statistical difference between the paradigms, more specifically showing the SC paradigm is worse than the RB2 paradigm and that there is no statistical difference between the RC and SC paradigms. However, there are some unusual observations shown which are taken out so they do not skew the data results. Subjects 12, 13, and 18 were all removed as to not skew the data. The following are the results with the outliers removed.

Two-way ANOVA: Accuracy versus Word, Paradigm

Source	DF	SS	MS	F	P
Word	1	53.3	53.29	0.13	0.724
Paradigm	2	10883.9	5441.93	12.84	0.000
Interaction	2	72.6	36.28	0.09	0.918
Error	114	48317.6	423.84		
Total	119	59327.4			

S = 20.59 R-Sq = 18.56% R-Sq(adj) = 14.99%

Table 3.4 Two-way ANOVA test for all three paradigms with the outliers removed

General Linear Model: Accuracy versus Paradigm

Factor	Type	Levels	Values
Paradigm	fixed	3	RB2, RC, SC

Analysis of Variance for Accuracy, using Adjusted SS for Tests

Source	DF	Seq SS	Adj SS	Adj MS	F	P
Paradigm	2	10883.9	10883.9	5441.9	13.14	0.000
Error	117	48443.5	48443.5	414.0		
Total	119	59327.4				

S = 20.3481 R-Sq = 18.35% R-Sq(adj) = 16.95%

Term	Coef	SE Coef	T	P
Constant	73.833	1.858	39.75	0.000
Paradigm				
RB2	6.275	2.627	2.39	0.019
RC	7.184	2.627	2.73	0.007

Unusual Observations for Accuracy

Obs	Accuracy	Fit	SE Fit	Residual	St Resid
10	4.670	60.375	3.217	-55.705	-2.77 R
26	14.330	60.375	3.217	-46.045	-2.29 R
30	0.000	60.375	3.217	-60.375	-3.00 R

R denotes an observation with a large standardized residual.
 Table 3.5 Post hoc Tukey test for all three paradigms with the outliers removed

With the outliers removed the Tukey test shows that there is statistical evidence to show that the RC and RB2 are better than the SC paradigm, in terms of accuracy. Another two-way ANOVA test was needed to determine whether or not there was any statistical difference between the RB2 and RC paradigms. Below are the two-way ANOVA and the post hoc Tukey results for the RC and RB2 paradigms for all 23 subjects.

Two-way ANOVA: Accuracy versus Word, Paradigm

Source	DF	SS	MS	F	P
Word	1	9.6	9.562	0.01	0.905
Paradigm	1	147.0	147.018	0.22	0.639
Interaction	1	47.8	47.837	0.07	0.789
Error	88	58253.4	661.970		
Total	91	58457.8			

S = 25.73 R-Sq = 0.35% R-Sq(adj) = 0.00%
 Table 3.6 Two-way ANOVA test for the RC and RB2 paradigms

General Linear Model: Accuracy versus Paradigm

Factor	Type	Levels	Values
Paradigm	fixed	2	RB2, RC

Analysis of Variance for Accuracy, using Adjusted SS for Tests

Source	DF	Seq SS	Adj SS	Adj MS	F	P
Paradigm	1	147.0	147.0	147.0	0.23	0.635
Error	90	58310.8	58310.8	647.9		
Total	91	58457.8				

S = 25.4538 R-Sq = 0.25% R-Sq(adj) = 0.00%

Term	Coef	SE Coef	T	P
Constant	72.844	2.654	27.45	0.000
Paradigm				
RB2	1.264	2.654	0.48	0.635

Unusual Observations for Accuracy

Obs	Accuracy	Fit	SE Fit	Residual	St Resid
12	14.330	71.580	3.753	-57.250	-2.27 R
13	19.000	71.580	3.753	-52.580	-2.09 R
18	0.000	71.580	3.753	-71.580	-2.84 R
35	4.670	71.580	3.753	-66.910	-2.66 R
36	9.330	71.580	3.753	-62.250	-2.47 R
41	4.670	71.580	3.753	-66.910	-2.66 R
64	14.330	74.108	3.753	-59.778	-2.37 R
87	9.330	74.108	3.753	-64.778	-2.57 R

R denotes an observation with a large standardized residual.
 Table 3.7 Post hoc Tukey test for the RC and RB2 paradigms

Table 3.6 and Table 3.7 show the results of the RC and RB2 paradigms compared to each other. The P-values show that there is no statistical difference between the accuracies of the two paradigms. To be thorough the outliers were removed and the two-way ANOVA test and post hoc Tukey test were redone and the results are below.

Two-way ANOVA: Accuracy versus Word, Paradigm

Source	DF	SS	MS	F	P
Word	1	4.5	4.513	0.02	0.888
Paradigm	1	16.5	16.526	0.07	0.787
Interaction	1	28.4	28.417	0.13	0.723
Error	76	17055.2	224.410		
Total	79	17104.7			

S = 14.98 R-Sq = 0.29% R-Sq(adj) = 0.00%

Table 3.8 Two-way ANOVA test for the RC and RB2 paradigms with the outliers removed

General Linear Model: Accuracy versus Paradigm

Factor	Type	Levels	Values
Paradigm	fixed	2	RB2, RC

Analysis of Variance for Accuracy, using Adjusted SS for Tests

Source	DF	Seq SS	Adj SS	Adj MS	F	P
Paradigm	1	16.5	16.5	16.5	0.08	0.784
Error	78	17088.1	17088.1	219.1		
Total	79	17104.7				

S = 14.8013 R-Sq = 0.10% R-Sq(adj) = 0.00%

Term	Coef	SE Coef	T	P
Constant	80.563	1.655	48.68	0.000
Paradigm				
RB2	-0.455	1.655	-0.27	0.784

Unusual Observations for Accuracy

Obs	Accuracy	Fit	SE Fit	Residual	St Resid
44	47.670	80.108	2.340	-32.438	-2.22 R
64	43.000	80.108	2.340	-37.108	-2.54 R
66	47.330	80.108	2.340	-32.778	-2.24 R

R denotes an observation with a large standardized residual.

Table 3.9 Post hoc Tukey test for the RC and RB2 paradigms with the outliers removed

The results of the Tukey test show that there is no statistical evidence between the accuracies of the RB2 and RC paradigms. With the RB2 paradigm having a better average accuracy for both words among all 23 subjects there are not enough of a gap between the two average accuracies. With more subjects there might be a statistical difference between the RC and RB2 paradigms.

3.4.3 Adjacency Results

Although the accuracies are similar between the RC and RB2 paradigms, the RB2 paradigm is superior to the RC and SC paradigms when it comes to the adjacency problem. The next three figures show the adjacency problem for all three paradigms. The center of the matrix shows the correct selection of the character. The darker of the two grays show the adjacent errors. The lighter of the two grays shows the errors that occurred in the same row or column but that were not adjacent to the target character.

Both Words - Single Character												
Row	5			2	3	1	3	3	1	3	2	1
	4			1	1	3	8	5	5	3	3	
	3	1	2	2	4	4	5	5	6	4	5	
	2	1	1	2	3	5	10	4	7	4	4	4
	1	5	2	3	6	7	15	8	8	2	2	2
	0	4	4	5	11	23	523	13	11	12	3	1
	-1	2	2	5	3	9	19	7	2	3	1	
	-2	2	3	2	3	2	10	6	2	1		2
	-3	1		2	5	4	3	7	5	2	5	
	-4	1	1	3	2	1	1	1	2	1	1	
	-5		2			5	8	5	2	6	3	
		-5	-4	-3	-2	-1	0	1	2	3	4	5
Column												
	Target Selections 523/966							54.14%				
	1° errors 70/966							7.25%				
	2° errors 99/966							10.25%				
	Other errors 274/966							28.36%				

Table 3.10 Adjacency errors of the single character paradigm

		Both Words - Row Column										
Row	5						6			1	1	
	4						11		1	1		
	3					1	11	2	3			1
	2		1				13	1			3	
	1	1			3	3	19	1	3	1		
	0		4	2	13	28	692	21	17	8	6	5
	-1		1	2	3	3	16	4		2	3	
	-2		2	1	1	4	6			1		1
	-3			2		3	6					
	-4			1	2	1	3	1	2			
	-5				1		8	1		1		
		-5	-4	-3	-2	-1	0	1	2	3	4	5
	Column											
	Target Selections 692/966							71.64%				
	1° errors 84/966							8.70%				
	2° errors 119/966							12.32%				
	Other errors 71/966							7.35%				

Table 3.11 Adjacency errors of the row/column paradigm

		Actual Region						
		Region 1	Region 2	Region 3	Region 4	Region 5	Region 6	Region 7
Intended Region	Region 1	212	13	12	12	8	9	10
	Region 2	13	218	8	12	3	12	10
	Region 3	16	6	219	12	5	8	10
	Region 4	11	8	7	213	13	11	13
	Region 5	12	5	13	4	226	5	11
	Region 6	10	14	16	12	11	194	19
	Region 7	8	12	19	10	9	10	208
Total region selected		282	276	294	275	275	249	281
Wrongfully selected		70	58	75	62	49	55	73
Region Accuracy		76.81%	78.99%	79.35%	77.17%	81.88%	70.29%	75.36%

Table 3.12 Adjacency errors of the region based paradigm

Putting the characters into regions instead of the traditional matrix format reduces the errors due to the adjacency problem. Another benefit of the region based paradigm is that the user has control of 49 characters instead of the original 36. A new feature to consider now with the region based paradigm is the errors per region. The next section covers the errors per region for the region based paradigm.

3.4.4 Region Error

One problem that is present in the region based paradigm is the errors per region. Figure 3.8 shows the average number of errors per region for all 23 subjects for both words over the three trials. There is an even distribution of errors among the regions showing that one region is not easier to select a character from than the others.

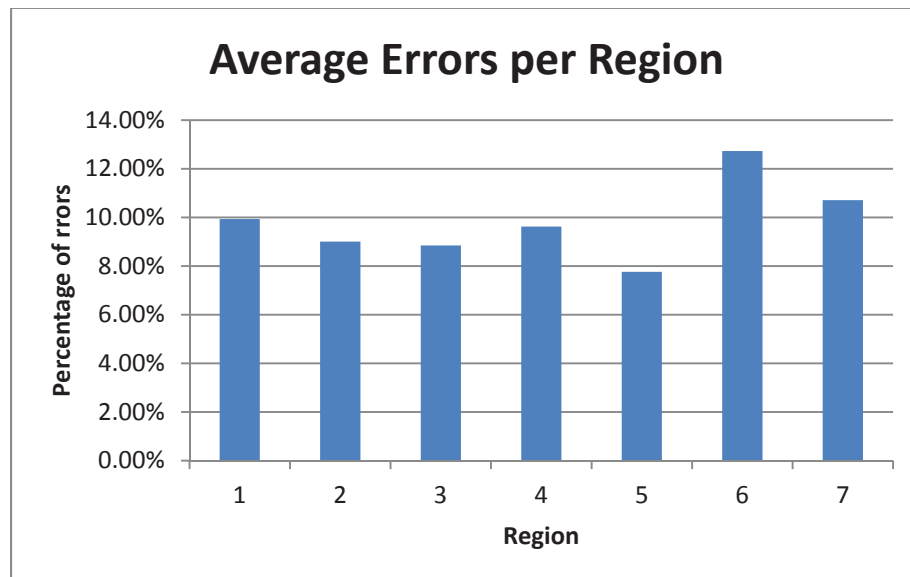

Figure 3.8 Percentage of errors per region for the RB2 paradigm for all 23 subjects

3.4.5 Questionnaire Results

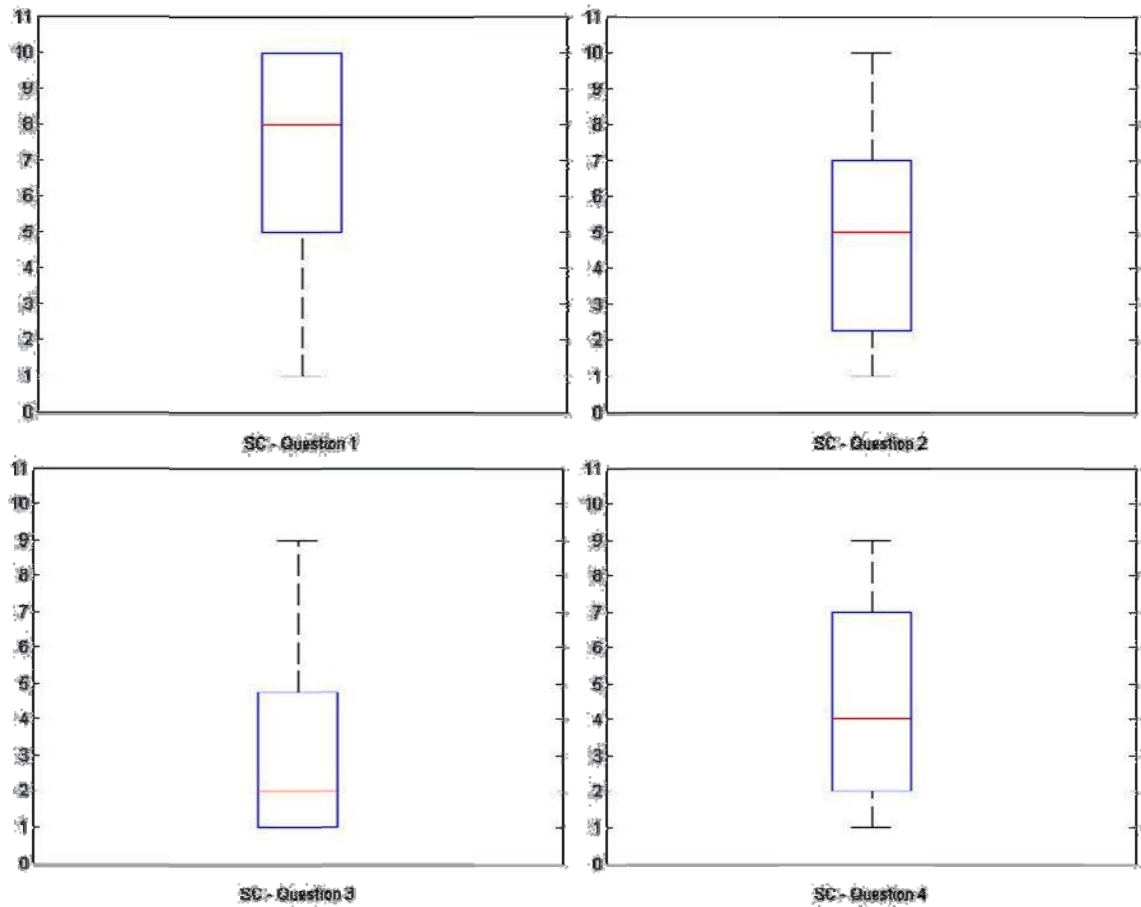

Figure 3.9 SC questions from the subject questionnaire form in Appendix B – Subject Questionnaire

The box plots above show the first four questions from the subject questionnaire form given to each subject after each paradigm test is complete. The box plot was used to represent this data to show the average of each question across the 23 subjects. The four questions are 1.) What was your level of fatigue after this experiment? 2.) How comfortable were you in counting the flashing targets? 3.) How would you rate this paradigm for spelling purposes? 4.) The experiment with this paradigm was easy to use? The rating scale declares 1 being the worst and 10 being the best.

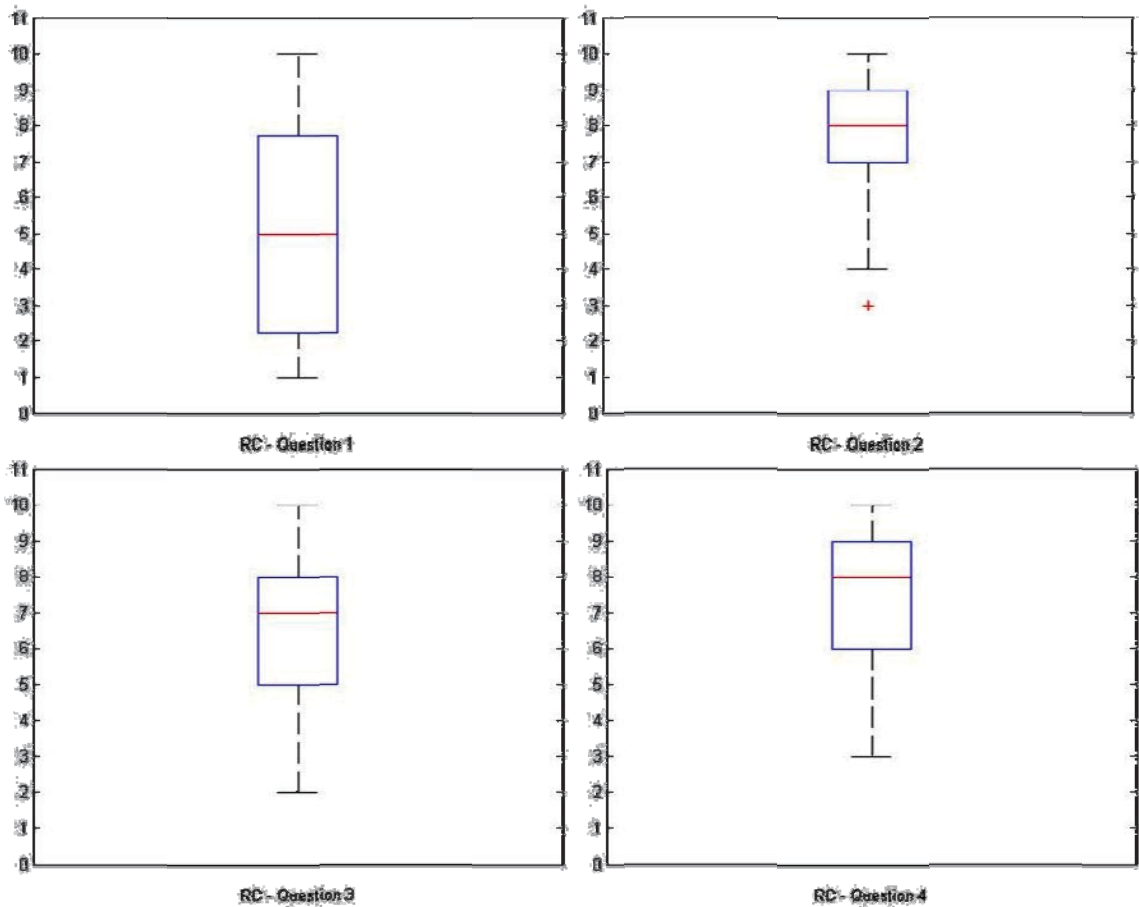

Figure 3.10 RC questions from the subject questionnaire form in Appendix B – Subject Questionnaire

The above box plots are the responses to the first four questions in the subject questionnaire for the RC paradigm. Looking at question one it is obvious that the level of fatigue was less for the RC and RB2 paradigms compared to the SC paradigm. Similar in question 2 the subjects were more comfortable in counting the flashes in the RC and RB2 paradigms compared to the SC paradigm. The next four box plots are the responses to the RB2 subject questionnaire.

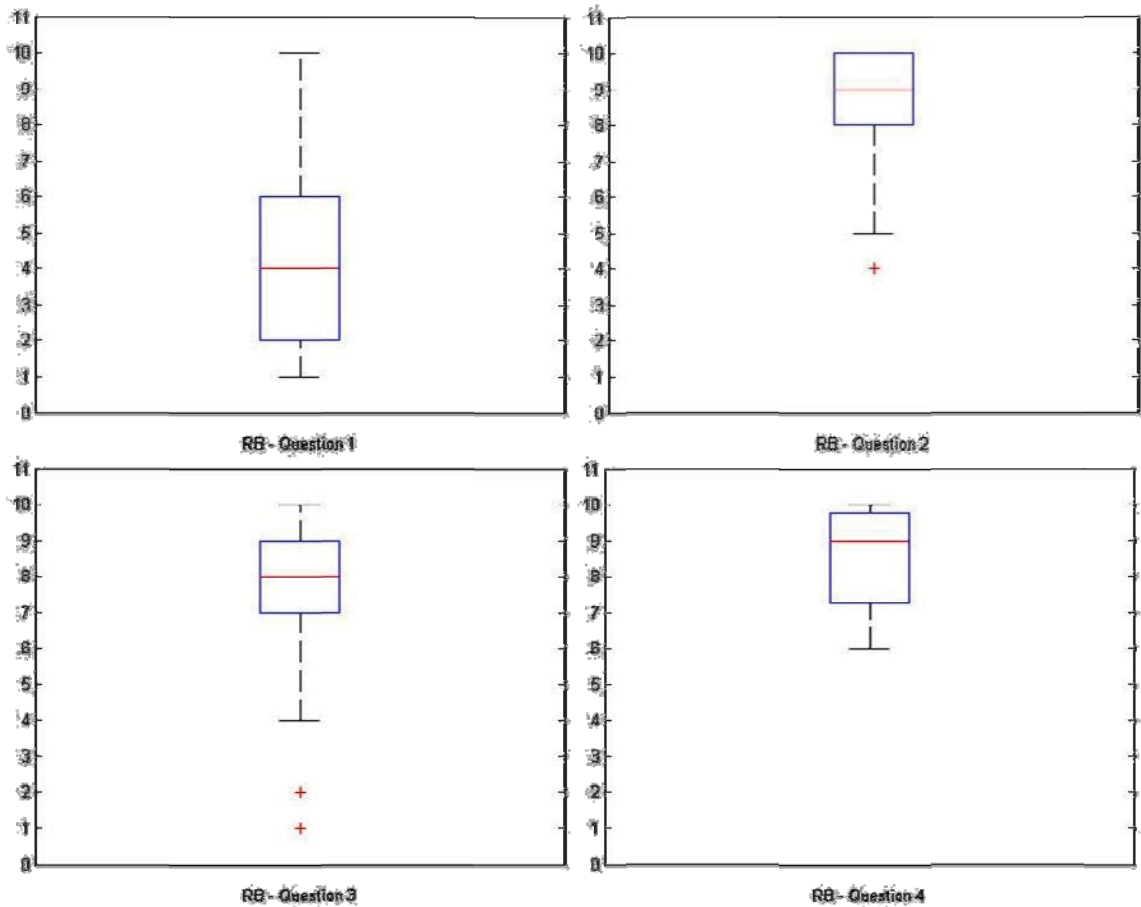

Figure 3.11 RB2 questions from the subject questionnaire form in Appendix B – Subject Questionnaire

Looking at question 3, rating the paradigm for spelling purposes, the subjects rated the RB2 paradigm the highest and the SC the lowest with the RC paradigm being slightly less than the RB2 paradigm. Finally, looking at the fourth question, the experiment with this paradigm was easy to use, the subjects again ranked the RB2 paradigm slightly above the RC paradigm while both are above the SC paradigm. The next page or so is the raw results to the fifth question on the subject questionnaire form, any specific thoughts. The results are in no order and the subjects that left this question blank were omitted from the results.

The following are the responses to the question “Any specific thoughts” for the SC paradigm:

- A.) It's easy but eyes get tired from staring at the letters for so long. Takes quite a bit of time to spell a word.
- B.) Don't use this algorithm. It is boring, slow, and poor at prediction.
- C.) My ADD kicked in watching 1 min for 1 letter. Is way too long.
- D.) Too long of time span between flashing the letter I wanted to choose-gave time to get distracted. Lg. black square left an after image-when switching to next letter I could see 2 images of black square.
- E.) Length of paradigm takes too long, focus is lost.
- F.) Accurate and easy to use; however, there were several times when my vision blurred and it was hard to concentrate because it took a long time per character.
- G.) This one was easiest on the eyes but required more attention than the other two but probably could have gone better if the numbers didn't flash randomly.
- H.) Too much flashing.

The following are the responses to the question “Any specific thoughts” for the RC paradigm:

- A.) Easy to select adjacent numbers.
- B.) Better than SC.
- C.) Black square leave distracting after image.
- D.) The flashing rows and columns were too distracting, making it hard to focus.
- E.) Actual words were easier to spell than the random characters.
- F.) This was fatiguing for my eyes more than anything else.
- G.) My eyes hurt.

H.) It doesn't work unless you're 100% focused.

The following are the responses to the question “Any specific thoughts” for the RB2 paradigm:

A.) Easy to separate the letter, less distractions from all of the flashing lights.

B.) Much better than other 2. May consider for use as a word selector (common words instead of letters).

C.) Does introducing color help?

D.) My brain likes grids better than hexagons.

E.) Easier to spell accurately than previous paradigm. Struggled most with numbers and symbols.

F.) I liked the regions. Made it easy to keep track of the letters/numbers/or symbols.

G.) This was much easier on my eyes than the row/column one.

H.) I liked having fewer potential characters at once.

Summarizing the opened ended results, it seems like the subjects liked the RB2 paradigm over the RC and SCS paradigms and RC over the SC paradigm. Also, a few of the subjects thought that the flash time was too long or there were too many flashes.

Another concern was when staring for an extended amount of time there is the chance of an afterimage when the subject blinks. There were many other concerns as well, mostly opinions about the individual paradigms.

The last piece of data to review is the brain computer interface subject questionnaire form that is filled out by every subject, the first half at the beginning of the test and the second half at the end of the test. The next two figures are showing the results from questions 1-

4 from the first half of the questionnaire. Figure 3.12 shows the results for only the first question, overall, how are you feeling today?, with 1 being the worst and 10 being the best.

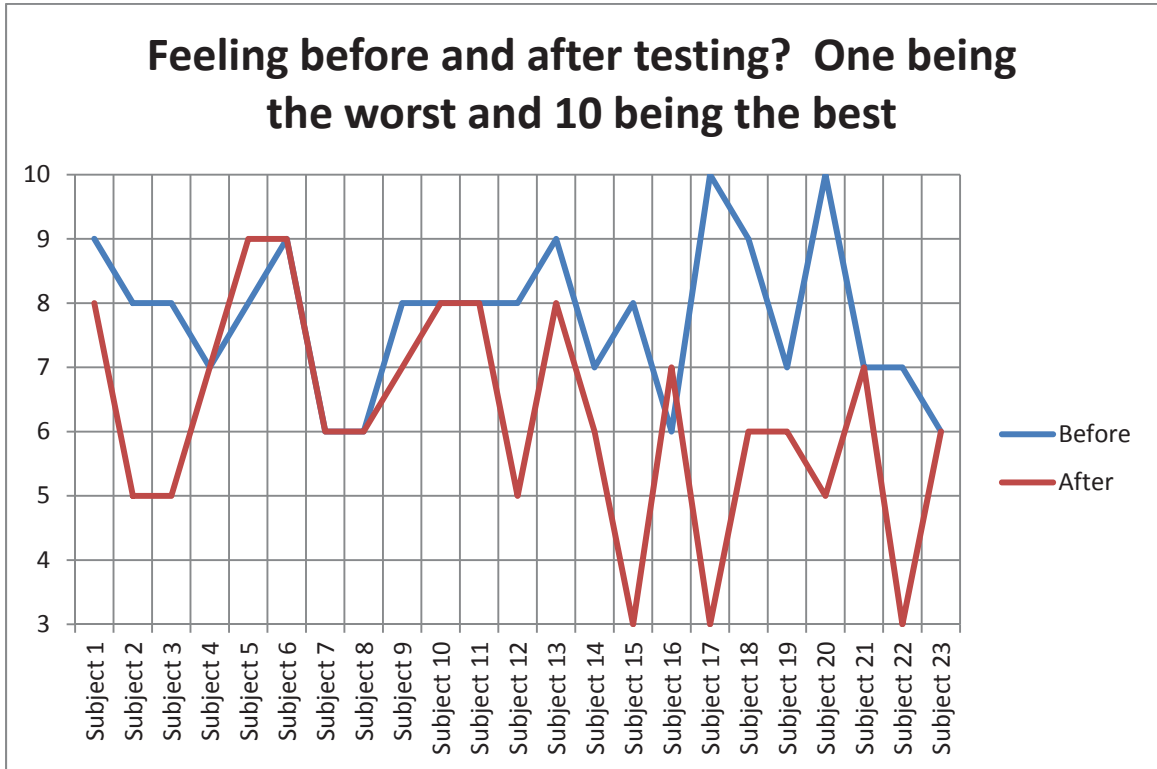

Figure 3.12 Results from question 1 and 7 of the brain computer interface subject questionnaire found in Appendix A – BCI Subject Questionnaire

Looking at the graph above the average subject was feeling pretty good the day of the test with an average rating of 7.78 out of 10. The average score for how the subject was feeling after the test was a 6.22 showing that most of the subjects were worn out over the testing period. This is important to consider if the subject has something else on their mind or is having a bad day they may not be able to perform as well on the tests.

The next graph shows the results to questions 2-4. The three questions are just to see if the subject feels stressed, if he or she is well rested, and if they can sit at a computer for

two hours. Most of the subjects said that they were well rested, not stressed out, and were able to sit at a computer for two hours.

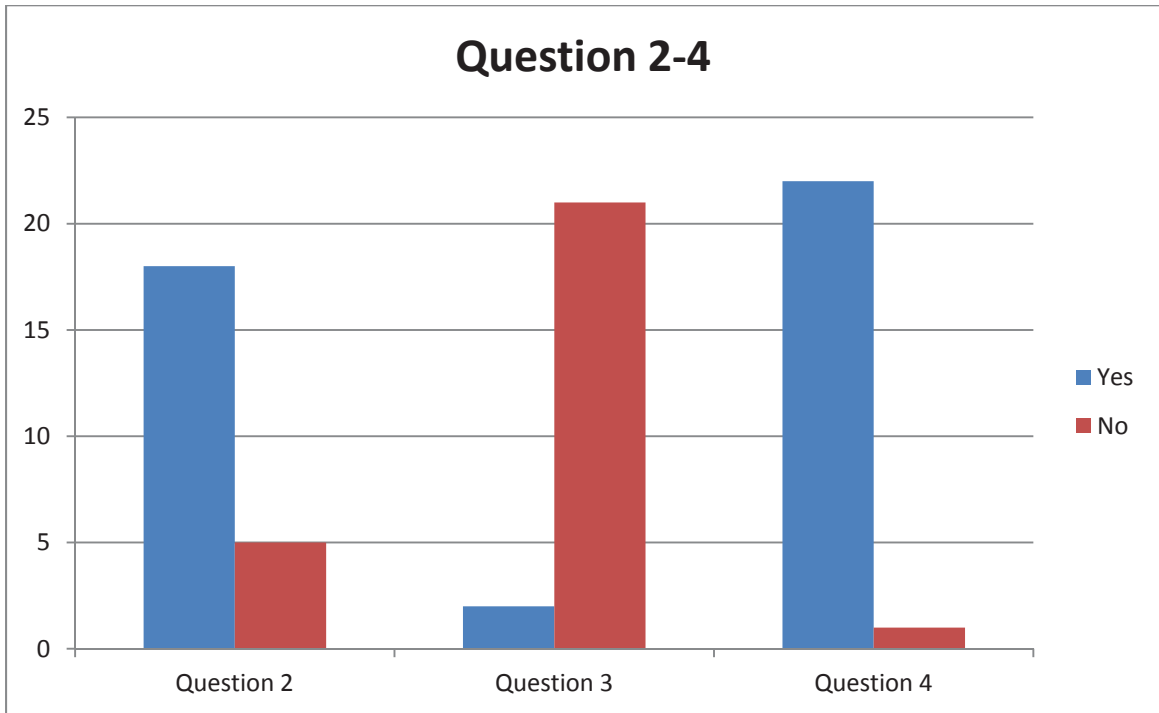

Figure 3.13 Results from question 2-4 of the brain computer interface subject questionnaire found in Appendix A – BCI Subject Questionnaire

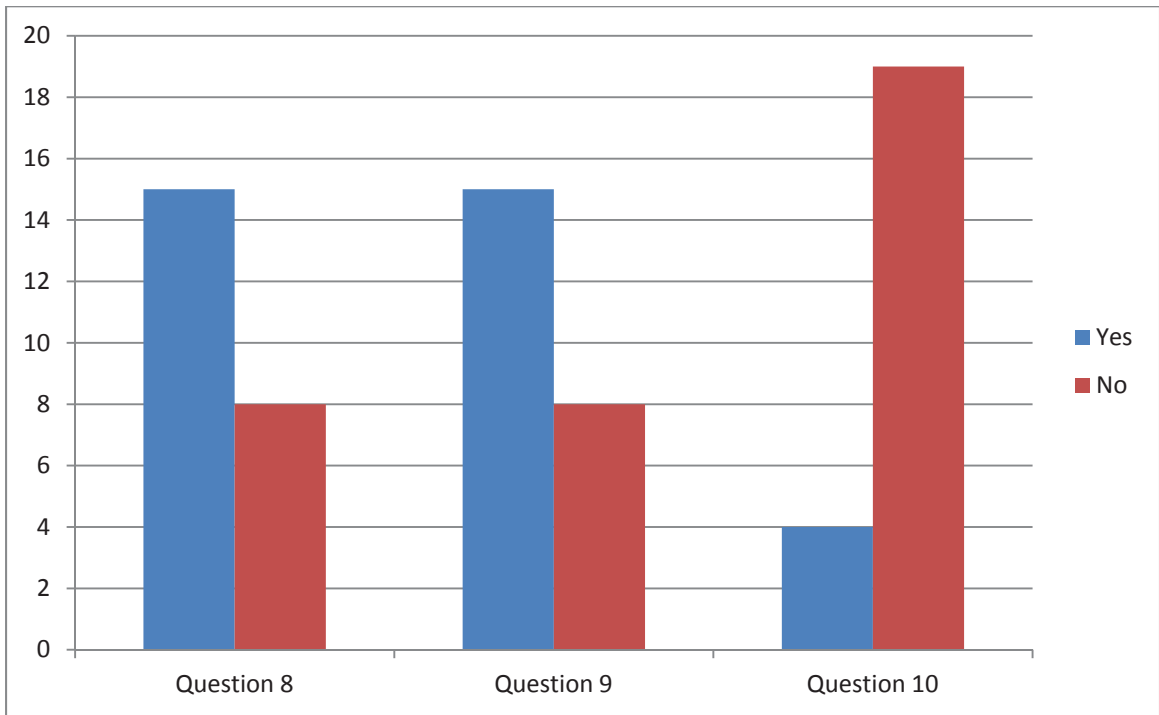

Figure 3.14 Results from question 8-10 of the brain computer interface subject questionnaire found in Appendix A – BCI Subject Questionnaire

The graph on the previous page is similar to the questions asked before the experiment. The questions were as follows: 8.) Are you feeling drowsy? 9.) are you feeling fatigued? 10.) Are you feeling stressed? Overall, most of the subjects were 2:1 on questions 8 and 9 favoring feeling drowsy and fatigued. While, most subjects said that they were not feeling stressed at the end of the experiments.

The following are the open ended results in no particular order, if a subject did not write anything in these sections nothing was recorded for them.

The following are the responses to the question “what changes would you make to the procedures?” in the brain computer interface subject questionnaire:

- A.) The first paradigm makes the eyes hurt quite a bit so a break between test would be helpful.
- B.) Remove single flash, test fatigue ruins concentration.
- C.) 2nd paradigm was too long (referring to the SC paradigm since it was the second when he took the test).
- D.) Get rid of the really long test.
- E.) Get rid of the single flashing letter test.
- F.) Take less time.
- G.) Singles letter speed up the process & slow down the letters with rows & columns.
Circle was right speed.
- H.) Nothing comes to mind.
- I.) The last test was over-tedious.
- J.) Full screen.

- K.) Shorter.
- L.) Make time for a break in the middle.
- M.) Make it go faster.
- N.) Not the last paradigm

The following are the responses to the question “were you easily distracted or unable to focus on the speller program” in the brain computer interface subject questionnaire:

- A.) At times, yes, but for the most part I was able to concentrate.
- B.) During test 1 (single flashes).
- C.) None.
- D.) None.
- E.) None.
- F.) Sometimes zoned the other letters out.
- G.) On the longer ones yes, shorter ones no.
- H.) Not really.
- I.) No.
- J.) No.
- K.) None.
- L.) Somewhat.
- M.) With the single letter it was hard to focus. Others were ok to focus on.
- N.) Yes, especially as the experiment progressed.
- O.) Yes.

P.) On the last one yes (referring to the SC paradigm since it was the last one when he took the test).

Q.) Yes.

R.) From time to time.

S.) Yes.

T.) Not really.

U.) Yes.

V.) Only the last paradigm (referring to the SC paradigm since it was the last one when she took the test).

W.) Yes, I would lose focus and think about stuff.

The following are the responses to the question “please write any other comments or suggestions here:” in the brain computer interface subject questionnaire:

A.) Speed up single letter program.

B.) Have it flash 3 times not 6

Overall, it seems like the subjects had a harder time concentrating on the SC paradigm since it took too long to complete. A lot of the changes that the subjects would have made would be to make the test shorter, have it flash less, or have it flash faster.

Looking over all the results it seems that the subjects preferred the RB2 paradigm, followed by the RC paradigm, and they really did not like the SC paradigm.

Chapter 4. Conclusion

4.1 Conclusion

Among all three experiments, it was found that the RC and RB paradigms outperformed the SC paradigm when it comes to accuracy and user friendliness. The RB paradigm did slightly better than the RC paradigm but not enough to show a significant difference. However, the key benefit of the RB over the RC is it was found to reduce the adjacency problem.

4.2 My Contributions

My contributions for this project were plentiful including programming the new paradigm, writing journal papers, attending conferences, poster presentations, and many other things. Detailed contributions that I made are listed as follows:

- 1) Working on the programming in MATLAB to make the region based paradigm ready for testing.
- 2) Tested 6 subjects comparing the SC, RC, RB1, and RB2 paradigms.
- 3) Changed the code for the region error experiment.
- 4) Tested 8 subjects for the region error experiment
- 5) Helped in writing, review, and testing for the “A comparison among several P300 Brain-Computer Interface Speller Paradigms” journal article.
- 6) Helped in writing, review, and testing for the “Determining the Region Accuracy of a Region-Based P300 Speller Paradigm.

- 7) Helped with the review and testing for the “P300-based Brain-Computer Interface Paradigm Design” paper.
- 8) Helped with the writing, testing, and review for submissions of conference papers.
 - a.) Patent Filed: “Device and method for rehabilitation and therapy using surface electromyography and biofeedback”, 2011. Inventors: A. V. Putnam, M. Dhawan, S. Gavett, C. Hahn, B. Lemke, R. Fazel-Rezai, #61/326,020, 2011.
 - b.) W. Ahmad, S. Gavett, R. Fazel-Rezai, “P300 Brain Computer Interface,” *2011 Design of Medical Devices Conference (DMD2011)*, April 12-14, 2011, Minneapolis, Minnesota, USA.
 - c.) W. Ahmad, S. Gavett, E. Schneider, R. Fazel-Rezai, “Determining the Region Accuracy of a Region-Based P300 Speller Paradigm,” *Journal of Medical Devices*, June 2011, vol. 5 (2), 027540.
 - d.) W. Ahmad, S. Gavett, and R. Fazel-Rezai, “Region-Based Hybrid Brain-Computer Interface Speller Paradigm,” *the Frank Low Research Day*, Grand Forks, ND, 2011.
 - e.) S. Gavett and R. Fazel-Rezai, “Evaluation of Paradigms for a P300 Based Brain Computer Interface Speller,” *the ND EPSCoR State Conference*, Fargo, ND, 2011.
 - f.) E. Schneider, S. Gavett, and R. Fazel-Rezai, “Virtual Keyboard based on P-300 Visual Evoked Potentials in Brain Signals,” *the ND EPSCoR State Conference*, Grand Forks, ND, 2010.
 - g.) W. Ahmad, S. Gavett, E. Schneider, and R. Fazel-Rezai, “Determining the Accuracy of Various Regions for a Brain-Computer Interface (BCI) Speller based on P300 Potentials,” *the ND EPSCoR State Conference*, Grand Forks, ND, 2010.
 - h.) W. Ahmad, S. Gavett, and R. Fazel-Rezai, “A new paradigm for brain-computer interface (BCI) speller based on p300 potentials,” *the Frank Low Research Day*, Grand Forks, ND, 2010.
 - i.) A. Putnam, S. Gavett, C. Hahn, M. Dhawan, and R. Fazel-Rezai, “EMC2 Muscle Maze: A Fun and Easy Way to Rehabilitate Muscles,” *the Frank Low Research Day*, Grand Forks, ND, 2010.

j.) S. Gavett, Z. Wygant, S. Amiri, and R. Fazel-Rezai, "Reducing Human Error in P300 Speller Paradigm for Brain-Computer Interface," *IEEE EMBS conference*, San Diego, CA, 2012

- 9) Have participated in multiple poster presentation, to name a few, Frank Low poster presentation, Engineering Research Summit, ND EPSCoR, and others.
- 10) Worked on but did not complete the coding for a predictive paradigm shown below in Figure 4.1.

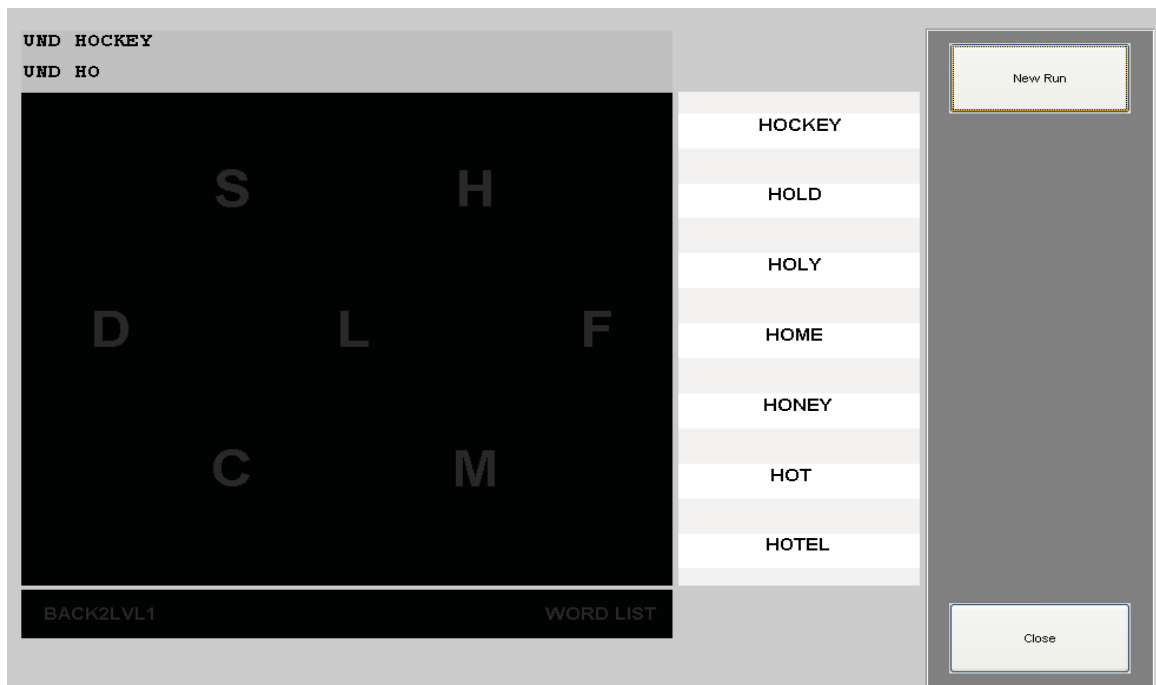

Figure 4.1 Predictive region based paradigm

- 11) Changed the code for the SC, RC, and RB2 paradigm experiment.
- 12) Tested 23 subjects and analyzed the results.

4.3 Future Works

In the future if someone were to continue this project I would like to see the predictive paradigm completed and tested. Comparing the RB-predictive with the regular RB and the RC paradigms. I would like to see a hybrid of the P300 based and SSVEP done with this experiment set up as well.

APPENDICES

APPENDIX A – BCI SUBJECT QUESTIONNAIRE

Subject ID: _____

Brain Computer Interface Subject Questionnaire

Please circle the best response. Questions 1-6 should be completed prior to testing.

1. Overall, how are you feeling today? One being the worst and 10 being the best.
1 2 3 4 5 6 7 8 9 10
 2. Do you feel well rested?
Yes No
 3. Do you feel stressed?
Yes No
 4. Can you sit at a computer performing tasks for up to 2 hours?
Yes No
 5. Do you have any pre-existing medical conditions that require specific medical attention?
Yes No
If yes, please explain _____
 6. Do you have any allergies?
Yes No
If yes, please list _____
-
-

To be completed after testing:

7. Overall, how are you feeling after testing? One being the worst and 10 being the best.
1 2 3 4 5 6 7 8 9 10
8. Are you feeling drowsy?
Yes No
9. Are you feeling fatigued?
Yes No
10. Are you feeling stressed?
Yes No
11. What changes would you make to the procedures?

12. Were you easily distracted or unable to focus on the speller program?

Please write any other comments or suggestions here:

Participant's Signature

Today's Date

APPENDIX B – SUBJECT QUESTIONNAIRE

Subject Questionnaire

Paradigm Name: _____
Date and Time: _____
Experiment No. _____
Subject ID: _____

All the questions are on the scale from 1 to 10, 1 being the worst and 10 being the best.

- 1. What was your level of fatigue after this experiment?
1 2 3 4 5 6 7 8 9 10
- 2. How comfortable were you in counting the flashing targets?
1 2 3 4 5 6 7 8 9 10
- 3. How would you rate this paradigm for spelling purposes?
1 2 3 4 5 6 7 8 9 10
- 4. The experiment with this paradigm was easy to use?
1 2 3 4 5 6 7 8 9 10
- 5. Any specific thoughts:

Subject Name:	N/A	Buffer Length [ms] - 800		Comments:	2 training runs with the row-column paradigm
Student ID:	N/A	Number of Flashes - 10			
Subject ID:	001	Mode - Copy Spelling			
Date:	7/29/2010	Flash Time [ms] - 100			
Time:		Dark Time [ms] - 60			
Start:	12:20 PM	Number of Channels - 8			
End:	2:40 PM	Order of paradigms - 3124			
Trial 1		Trial 2			
RBP1	W A T E R	RBP1	W A T E R		
Level 1	3 1 1 1 1	Level 1	3 1 1 1 1		W A T E R
Level 1 act	3 1 1 1 1	level 1 act	3 1 1 1 1		3 1 1 1 1
Level 2	5 3 2 1 6	Level 2	5 3 2 1 6		5 3 2 1 6
Level 2 act	5 1 2 1 6	Level 2 act	5 3 2 1 6		5 3 2 1 6
RBP1	L U C A S	RBP1	L U C A S		
Level 1	2 3 2 1 2	Level 1	2 3 2 1 2		L U C A S
Level 1 act	2 3 2 1 2	level 1 act	2 3 2 1 1		2 3 2 1 2
Level 2	4 1 6 3 1	Level 2	4 1 6 3 1		4 1 6 3 1
Level 2 act	4 1 6 3 1	Level 2 act	4 1 6 3 1		4 1 6 3 1
RBP2	W A T E R	RBP2	W A T E R		
Level 1	4 1 3 1 3	Level 1	4 1 3 1 3		W A T E R
Level 1 act	4 1 3 1 3	level 1 act	4 1 3 1 3		4 1 3 1 3
Level 2	2 1 6 5 4	Level 2	2 1 6 5 4		4 1 3 1 3
Level 2 act	2 1 6 5 4	Level 2 act	2 1 6 5 4		2 1 6 5 4
RBP2	L U C A S	RBP2	L U C A S		
Level 1	2 3 1 1 3	Level 1	2 3 1 1 3		L U C A S
Level 1 act	2 3 1 1 3	level 1 act	2 3 1 1 3		2 3 1 1 3
Level 2	5 7 3 1 5	Level 2	5 7 3 1 5		5 7 3 1 5
Level 2 act	5 7 3 1 5	Level 2 act	6 7 3 1 4		5 7 3 1 5



Subject Name:	N/A	Buffer Length [ms] - 800		Comments:	4 training sessions in row-column, 6 flashes for single character
Student ID:	N/A	Number of Flashes - 10			
Subject ID:	002	Mode - Copy Spelling			
Date:	7/29/2010	Flash Time [ms] - 100			
Time:		Dark Time [ms] - 60			
Start:	6:00 PM	Number of Channles - 8			
End:	8:15 PM	Order of paradigms - 4312			
Trial 1		Trial 2			
RBPI	W A T E R	RBPI	W A T E R		W A T E R
Level 1	3 1 1 1 1	Level 1	3 1 1 1 1		3 1 1 1 1
level 1 act	3 1 7 1 1	level 1 act	3 1 1 1 1		3 1 1 1 1
Level 2	5 3 2 1 6	Level 2	5 3 2 1 6		5 3 2 1 6
Level 2 act	5 3 2 1 6	Level 2 act	5 3 2 1 6		5 3 2 1 6
RBPI	L U C A S	RBPI	L U C A S		L U C A S
Level 1	2 3 2 1 2	Level 1	2 3 2 1 2		2 3 2 1 2
level 1 act	4 7 2 1 2	level 1 act	6 3 2 1 2		2 3 7 1 2
Level 2	4 1 6 3 1	Level 2	4 1 6 3 1		4 1 6 3 1
Level 2 act	4 7 6 3 1	Level 2 act	6 1 6 3 1		4 1 6 3 1
RBPI	W A T E R	RBPI	W A T E R		W A T E R
Level 1	4 1 3 1 3	Level 1	4 1 3 1 3		4 1 3 1 3
level 1 act	4 1 3 1 3	level 1 act	4 1 3 4 3		4 1 3 1 3
Level 2	2 1 6 5 4	Level 2	2 1 6 5 4		2 1 6 5 4
Level 2 act	2 1 6 5 4	Level 2 act	2 1 6 5 4		2 1 6 5 3
RBPI	L U C A S	RBPI	L U C A S		L U C A S
Level 1	2 3 1 1 3	Level 1	2 3 1 1 3		2 3 1 1 3
level 1 act	2 3 1 1 4	level 1 act	2 3 1 7 3		2 3 1 4 3
Level 2	5 7 3 1 5	Level 2	5 7 3 1 5		5 7 3 1 5
Level 2 act	5 3 4 1 5	Level 2 act	5 7 6 1 5		5 7 3 1 1



Subject Name:	N/A	Buffer Length [ms] - 800		Comments:	3 training sessions in row-column paradigm, 6 flashes in single character
Student ID:	N/A	Number of Flashes - 10			
Subject ID:	003	Mode - Copy Spelling			
Date:	7/30/2010	Flash Time [ms] - 100			
Time:		Dark Time [ms] - 60			
Start:	11:15 AM	Number of Channles - 8			
End:	1:00 PM	Order of paradigms - 4231			
Trial 1		Trial 2			
RBP1	W A T E R	RBP1	W A T E R		W A T E R
Level 1	3 1 1 1 1	Level 1	3 1 1 1 1		3 1 1 1 1
level 1 act	3 1 1 1 1	level 1 act	3 1 1 1 1		3 1 1 1 1
Level 2	5 3 2 1 6	Level 2	5 3 2 1 6		5 3 2 1 6
Level 2 act	5 3 2 1 6	Level 2 act	5 3 2 1 6		5 3 2 1 6
RBP1	L U C A S	RBP1	L U C A S		L U C A S
Level 1	2 3 2 1 2	Level 1	2 3 2 1 2		2 3 2 1 2
level 1 act	2 3 2 1 3	level 1 act	2 3 2 1 2		2 3 2 1 2
Level 2	4 1 6 3 1	Level 2	4 1 6 3 1		4 1 6 3 1
Level 2 act	4 1 6 3 1	Level 2 act	4 1 6 3 1		4 1 6 3 1
RBP2	W A T E R	RBP2	W A T E R		W A T E R
Level 1	4 1 3 1 3	Level 1	4 1 3 1 3		4 1 3 1 3
level 1 act	4 1 3 1 3	level 1 act	4 1 3 1 3		4 1 3 1 3
Level 2	2 1 6 5 4	Level 2	2 1 6 5 4		2 1 6 5 4
Level 2 act	2 1 6 5 4	Level 2 act	2 1 6 5 4		2 1 6 5 4
RBP2	L U C A S	RBP2	L U C A S		L U C A S
Level 1	2 3 1 1 3	Level 1	2 3 1 1 3		2 3 1 1 3
level 1 act	2 3 1 1 3	level 1 act	2 3 1 1 3		2 3 1 1 3
Level 2	5 7 3 1 5	Level 2	5 7 3 1 5		5 7 3 1 5
Level 2 act	5 7 3 1 5	Level 2 act	5 7 3 1 5		5 7 3 1 5



Subject Name:	N/A	Buffer Length [ms] - 800		Comments:		3 training sessions in row-column paradigm, 6 flashes for the single character	
Student ID:	N/A	Number of Flashes - 10					
Subject ID:	004	Mode - Copy Spelling					
Date:	7/30/2010	Flash Time [ms] - 100					
Time:		Dark Time [ms] - 60					
Start:	2:50 PM	Number of Channles - 8					
End:	4:50 PM	Order of paradigms - 1423					
Trial 1		Trial 2					
RBP1	W A T E R	RBP1	W A T E R			Trial 3	
Level 1	3 1 1 1 1	Level 1	3 1 1 1 1			RBP1	W A T E R
level 1 act	3 1 1 1 1	level 1 act	3 1 1 1 1			Level 1	3 1 1 1 1
Level 2	5 3 2 1 6	Level 2	5 3 2 1 6			level 1 act	
Level 2 act	5 3 2 1 6	Level 2 act	5 3 2 1 6			Level 2	5 3 2 1 6
						Level 2 act	
RBP1	L U C A S	RBP1	L U C A S				
Level 1	2 3 2 1 2	Level 1	2 3 2 1 2			RBP1	L U C A S
level 1 act	2 3 2 1 2	level 1 act	2 3 1 1 2			Level 1	2 3 2 1 2
Level 2	4 1 6 3 1	Level 2	4 1 6 3 1			level 1 act	2 3 2 1 2
Level 2 act	4 1 6 3 1	Level 2 act	4 1 5 3 1			Level 2	4 1 6 3 1
						Level 2 act	4 1 6 5 1
RBP2	W A T E R	RBP2	W A T E R				
Level 1	4 1 3 1 3	Level 1	4 1 3 1 3			RBP2	W A T E R
level 1 act	4 1 3 1 3	level 1 act	4 1 3 1 3			Level 1	4 1 3 1 3
Level 2	2 1 6 5 4	Level 2	2 1 6 5 4			level 1 act	4 1 3 1 3
Level 2 act	2 1 6 5 4	Level 2 act	2 1 6 5 4			Level 2	2 1 6 5 4
						Level 2 act	2 1 6 5 4
RBP2	L U C A S	RBP2	L U C A S				
Level 1	2 3 1 1 3	Level 1	2 3 1 1 3			RBP2	L U C A S
level 1 act	2 3 1 1 3	level 1 act	2 3 1 1 3			Level 1	2 3 1 1 3
Level 2	5 7 3 1 5	Level 2	5 7 3 1 5			level 1 act	2 3 1 1 3
Level 2 act	5 7 3 1 5	Level 2 act	5 7 3 1 5			Level 2	5 7 3 1 5
						Level 2 act	5 7 3 1 5



Subject Name:	N/A	Buffer Length [ms] - 800		Comments:	2 training sessions in row-column paradigm, 6 flashes for single character
Student ID:	N/A	Number of Flashes - 10			
Subject ID:	006	Mode - Copy Spelling			
Date:	7/30/2010	Flash Time [ms] - 100			
Time:		Dark Time [ms] - 60			
Start:	7:25 PM	Number of Channles - 8			
End:	9:12 PM	Order of paradigms - 2413			
Trial 1		Trial 2		Trial 3	
RBP1	W A T E R	RBP1	W A T E R	RBP1	W A T E R
Level 1	3 1 1 1 1	Level 1	3 1 1 1 1	Level 1	3 1 1 1 1
level 1 act	3 1 1 1 1	level 1 act	3 1 1 1 1	level 1 act	3 1 1 1 1
Level 2	5 3 2 1 6	Level 2	5 3 2 1 6	Level 2	5 3 2 1 6
Level 2 act	5 3 2 1 6	Level 2 act	5 3 2 1 6	Level 2 act	5 3 2 1 6
RBP1	L U C A S	RBP1	L U C A S	RBP1	L U C A S
Level 1	2 3 2 1 2	Level 1	2 3 2 1 2	Level 1	2 3 2 1 2
level 1 act	2 3 2 1 2	level 1 act	2 3 2 1 2	level 1 act	2 3 2 1 2
Level 2	4 1 6 3 1	Level 2	4 1 6 3 1	Level 2	4 1 6 3 1
Level 2 act	4 1 6 3 1	Level 2 act	4 1 6 3 1	Level 2 act	4 1 6 3 1
RBP2	W A T E R	RBP2	W A T E R	RBP2	W A T E R
Level 1	4 1 3 1 3	Level 1	4 1 3 1 3	Level 1	4 1 3 1 3
level 1 act	4 1 3 1 3	level 1 act	4 1 3 1 3	level 1 act	4 1 3 1 3
Level 2	2 1 6 5 4	Level 2	2 1 6 5 4	Level 2	2 1 6 5 4
Level 2 act	2 1 6 5 4	Level 2 act	2 1 6 5 4	Level 2 act	2 1 6 5 4
RBP2	L U C A S	RBP2	L U C A S	RBP2	L U C A S
Level 1	2 3 1 1 3	Level 1	2 3 1 1 3	Level 1	2 3 1 1 3
level 1 act	2 3 1 1 3	level 1 act	2 3 1 1 3	level 1 act	2 3 1 1 3
Level 2	5 7 3 1 5	Level 2	5 7 3 1 5	Level 2	5 7 3 1 5
Level 2 act	5 7 3 1 5	Level 2 act	5 7 3 1 5	Level 2 act	5 7 3 1 5



APPENDIX D –RESULTS FROM THE ERRORS PER REGION EXPERIMENT

Region Based testing the regions

Subject Name: _____ N/A _____ Date: __8/9/2010_____

Subject Student ID: _____ N/A _____ Subject ID: _____ 007 _____ Time: _____ 11:20 am _____

Trial 1										Trial 11									
Order	4	3	5	6	7	1	2	Percent		Order	3	4	5	6	1	2	7	Percent	
Actual	4	3	5	6	2	4	2	71.43%		Actual	3	7	6	6	1	2	7	71.43%	

Trial 2										Trial 12									
Order	5	2	3	1	7	4	6	Percent		Order	2	3	5	4	7	6	1	Percent	
Actual	5	4	3	2	7	4	1	57.14%		Actual	2	3	5	3	7	6	2	71.43%	

Trial 3										Trial 13									
Order	3	4	1	7	6	2	5	Percent		Order	3	6	5	1	7	2	4	Percent	
Actual	3	6	6	6	6	7	5	42.86%		Actual	3	6	5	1	7	2	4	100.00%	

Trial 4										Trial 14									
Order	1	6	5	2	3	4	7	Percent		Order	6	1	3	2	7	5	4	Percent	
Actual	1	6	5	2	3	4	2	85.71%		Actual	6	1	5	2	7	5	1	71.43%	

Trial 5										Trial 15									
Order	1	5	6	7	4	2	3	Percent		Order	1	7	5	2	3	4	6	Percent	
Actual	1	5	1	7	2	6	6	42.86%		Actual	6	7	5	2	3	4	6	85.71%	

Trial 6										Trial 16									
Order	4	2	6	5	1	3	7	Percent		Order	7	6	3	2	5	4	1	Percent	
Actual	4	2	1	6	1	7	7	57.14%		Actual	7	2	3	2	5	4	1	85.71%	

Trial 7										Trial 17									
Order	7	6	4	5	1	3	2	Percent		Order	3	2	7	4	6	5	1	Percent	
Actual	7	6	4	2	1	6	2	71.43%		Actual	3	2	7	4	6	5	1	100.00%	

Trial 8										Trial 18									
Order	3	2	5	6	1	7	4	Percent		Order	4	1	7	2	6	5	3	Percent	
Actual	3	2	5	7	1	7	4	85.71%		Actual	4	1	2	2	6	2	3	71.43%	

Trial 9										Trial 19									
Order	6	3	4	7	2	1	5	Percent		Order	4	1	6	7	2	3	5	Percent	
Actual	6	3	2	7	2	1	7	71.43%		Actual	4	3	6	7	2	3	5	85.71%	

Trial 10										Trial 20									
Order	6	1	5	4	7	3	2	Percent		Order	1	2	4	3	7	6	5	Percent	
Actual	6	1	5	5	7	3	1	71.43%		Actual	1	2	4	3	2	4	5	71.43%	

Region Based testing the regions																	
Subject Name: _____ N/A _____										Date: <u>8/10/2010</u>							
Subject Student ID: _____ N/A _____										Subject ID: <u>008</u>							
										Time: <u>10:35 am</u>							
Trial 1								Trial 11									
Order	3	7	1	5	4	2	6	Percent	Order	2	3	4	7	5	1	6	Percent
Actual	3	7	1	2	4	2	6	85.71%	Actual	2	6	3	6	4	4	6	28.57%
Trial 2								Trial 12									
Order	5	3	7	2	1	6	4	Percent	Order	4	7	2	6	5	1	3	Percent
Actual	5	2	7	2	3	6	4	71.43%	Actual	4	1	2	6	5	7	3	71.43%
Trial 3								Trial 13									
Order	5	3	6	7	2	4	1	Percent	Order	4	1	5	2	6	3	7	Percent
Actual	5	5	6	7	2	4	1	85.71%	Actual	4	1	5	2	3	1	7	71.43%
Trial 4								Trial 14									
Order	3	2	5	1	6	4	7	Percent	Order	4	2	3	5	7	6	1	Percent
Actual	3	2	5	1	6	4	5	85.71%	Actual	4	2	3	3	7	6	3	85.71%
Trial 5								Trial 15									
Order	6	5	4	7	2	1	3	Percent	Order	5	2	6	3	4	7	1	Percent
Actual	6	4	7	7	2	2	3	57.14%	Actual	5	2	3	3	3	5	1	57.14%
Trial 6								Trial 16									
Order	1	3	5	4	6	7	2	Percent	Order	5	1	7	2	4	3	6	Percent
Actual	1	3	1	7	4	7	2	57.14%	Actual	5	1	7	2	1	3	6	85.71%
Trial 7								Trial 17									
Order	3	2	1	5	4	7	6	Percent	Order	2	7	6	4	1	3	5	Percent
Actual	3	2	7	5	4	7	7	71.43%	Actual	2	7	2	3	1	1	2	42.86%
Trial 8								Trial 18									
Order	5	2	1	3	6	7	4	Percent	Order	7	6	3	4	5	1	2	Percent
Actual	5	7	1	3	6	4	4	71.43%	Actual	7	6	3	3	5	1	2	85.71%
Trial 9								Trial 19									
Order	1	2	6	7	4	3	5	Percent	Order	1	4	3	6	2	7	5	Percent
Actual	1	7	6	5	6	3	5	57.14%	Actual	1	4	3	6	2	7	5	100.00%
Trial 10								Trial 20									
Order	3	7	1	2	4	5	6	Percent	Order	5	2	6	4	7	3	1	Percent
Actual	5	7	5	2	4	5	6	71.43%	Actual	5	2	6	3	7	2	6	57.14%

Region Based testing the regions																	
Subject Name: <u> N/A </u>													Date: <u> 8/11/2010 </u>				
Subject Student ID: <u> N/A </u>										Subject ID: <u> 009 </u>			Time: <u> 10:15 am </u>				
Trial 1											Trial 11						
Order	6	3	7	5	1	2	4	Percent	Order	1	4	3	7	6	2	5	Percent
Actual	6	3	7	5	1	4	4	85.71%	Actual	1	4	3	7	6	2	5	100.00%
Trial 2											Trial 12						
Order	4	7	1	6	2	3	5	Percent	Order	7	2	5	6	4	3	1	Percent
Actual	4	7	1	6	2	3	5	100.00%	Actual	7	2	5	6	4	3	1	100.00%
Trial 3											Trial 13						
Order	2	3	7	5	1	4	6	Percent	Order	1	5	7	2	6	3	4	Percent
Actual	2	3	7	5	1	4	6	100.00%	Actual	1	5	7	2	6	3	4	100.00%
Trial 4											Trial 14						
Order	1	7	4	6	5	2	3	Percent	Order	1	3	7	5	2	6	4	Percent
Actual	1	7	4	6	5	2	3	100.00%	Actual	1	3	7	5	2	6	3	85.71%
Trial 5											Trial 15						
Order	4	6	7	2	5	1	3	Percent	Order	7	2	6	1	3	4	5	Percent
Actual	4	6	7	2	5	1	3	100.00%	Actual	7	2	6	1	3	4	5	100.00%
Trial 6											Trial 16						
Order	5	3	7	6	2	1	4	Percent	Order	7	3	1	5	4	2	6	Percent
Actual	5	3	7	6	2	1	4	100.00%	Actual	7	3	1	5	4	2	6	100.00%
Trial 7											Trial 17						
Order	3	5	4	6	7	1	2	Percent	Order	4	2	1	5	6	7	3	Percent
Actual	3	5	4	6	7	1	2	100.00%	Actual	4	2	1	5	3	7	3	85.71%
Trial 8											Trial 18						
Order	6	5	2	7	4	3	1	Percent	Order	1	7	3	2	5	4	6	Percent
Actual	6	5	2	7	4	3	1	100.00%	Actual	1	7	3	6	5	4	6	85.71%
Trial 9											Trial 19						
Order	4	6	2	7	3	5	1	Percent	Order	3	7	2	1	6	5	4	Percent
Actual	4	6	2	1	3	5	1	85.71%	Actual	3	7	2	1	6	5	4	100.00%
Trial 10											Trial 20						
Order	5	6	7	4	1	2	3	Percent	Order	7	4	2	6	3	1	5	Percent
Actual	5	6	7	4	1	2	3	100.00%	Actual	7	4	2	6	3	1	5	100.00%

Region Based testing the regions																	
Subject Name: _____ N/A _____							Date: <u>8/12/2010</u>										
Subject Student ID: _____ N/A _____							Subject ID: <u>010</u>				Time: <u>3:10 pm</u>						
Trial 1							Trial 11										
Order	6	3	7	5	1	2	4	Percent	Order	7	4	2	6	3	1	5	Percent
Actual	6	3	7	5	1	2	2	85.71%	Actual	7	4	2	6	3	1	1	85.71%
Trial 2							Trial 12										
Order	4	7	1	6	2	3	5	Percent	Order	1	4	3	7	6	2	5	Percent
Actual	4	7	1	6	2	3	5	100.00%	Actual	1	4	3	7	6	2	5	100.00%
Trial 3							Trial 13										
Order	2	3	7	5	1	4	6	Percent	Order	7	2	5	6	4	3	1	Percent
Actual	2	3	7	5	1	4	6	100.00%	Actual	7	2	5	6	4	3	1	100.00%
Trial 4							Trial 14										
Order	1	7	4	6	5	2	3	Percent	Order	1	5	7	2	6	3	4	Percent
Actual	1	7	4	6	5	7	3	85.71%	Actual	1	5	7	2	6	3	5	85.71%
Trial 5							Trial 15										
Order	4	6	7	2	5	1	3	Percent	Order	1	3	7	5	2	6	4	Percent
Actual	4	6	7	2	5	1	3	100.00%	Actual	1	3	7	5	2	6	4	100.00%
Trial 6							Trial 16										
Order	5	3	7	6	2	1	4	Percent	Order	7	2	6	1	3	4	5	Percent
Actual	5	3	7	6	2	1	4	100.00%	Actual	7	2	6	1	3	4	5	100.00%
Trial 7							Trial 17										
Order	3	5	4	6	7	1	2	Percent	Order	7	3	1	5	4	2	6	Percent
Actual	3	5	4	6	7	1	2	100.00%	Actual	7	3	1	5	4	2	6	100.00%
Trial 8							Trial 18										
Order	6	5	2	7	4	3	1	Percent	Order	4	2	1	5	6	7	3	Percent
Actual	6	5	2	7	4	3	1	100.00%	Actual	4	2	1	5	6	7	3	100.00%
Trial 9							Trial 19										
Order	4	6	2	7	3	5	1	Percent	Order	1	7	3	2	5	4	6	Percent
Actual	4	6	3	7	3	5	1	85.71%	Actual	1	7	3	2	5	4	6	100.00%
Trial 10							Trial 20										
Order	5	6	7	4	1	2	3	Percent	Order	3	7	2	1	6	5	4	Percent
Actual	5	6	7	1	1	2	3	85.71%	Actual	3	7	2	1	6	5	4	100.00%

Region Based testing the regions																	
Subject Name: <u> N/A </u>								Date: <u> 8/13/2010 </u>									
Subject Student ID: <u> N/A </u>								Subject ID: <u> 011 </u>				Time: <u> 1:50 pm </u>					
Trial 1								Trial 11									
Order	6	3	7	5	1	2	4	Percent	Order	7	4	2	6	3	1	5	Percent
Actual	7	3	7	5	1	2	4	85.71%	Actual	7	6	7	3	2	7	5	28.57%
Trial 2								Trial 12									
Order	4	7	1	6	2	3	5	Percent	Order	1	4	3	7	6	2	5	Percent
Actual	4	7	1	3	4	5	2	42.86%	Actual	7	4	2	4	4	2	7	28.57%
Trial 3								Trial 13									
Order	2	3	7	5	1	4	6	Percent	Order	7	2	5	6	4	3	1	Percent
Actual	2	3	2	3	6	4	6	57.14%	Actual	7	2	5	7	4	3	6	71.43%
Trial 4								Trial 14									
Order	1	7	4	6	5	2	3	Percent	Order	1	5	7	2	6	3	4	Percent
Actual	7	5	5	6	5	2	3	57.14%	Actual	1	5	7	2	6	3	4	100.00%
Trial 5								Trial 15									
Order	4	6	7	2	5	1	3	Percent	Order	1	3	7	5	2	6	4	Percent
Actual	4	6	2	4	4	7	3	42.86%	Actual	2	1	3	2	2	3	3	28.57%
Trial 6								Trial 16									
Order	5	3	7	6	2	1	4	Percent	Order	7	2	6	1	3	4	5	Percent
Actual	4	3	2	5	1	5	4	28.57%	Actual	7	2	1	4	3	4	5	71.43%
Trial 7								Trial 17									
Order	3	5	4	6	7	1	2	Percent	Order	7	3	1	5	4	2	6	Percent
Actual	4	5	4	7	7	3	2	57.14%	Actual	2	3	3	3	7	4	6	28.57%
Trial 8								Trial 18									
Order	6	5	2	7	4	3	1	Percent	Order	4	2	1	5	6	7	3	Percent
Actual	6	1	2	7	2	3	1	71.43%	Actual	7	6	6	6	5	7	7	14.29%
Trial 9								Trial 19									
Order	4	6	2	7	3	5	1	Percent	Order	1	7	3	2	5	4	6	Percent
Actual	6	6	5	7	3	5	6	57.14%	Actual	2	4	3	2	4	2	1	28.57%
Trial 10								Trial 20									
Order	5	6	7	4	1	2	3	Percent	Order	3	7	2	1	6	5	4	Percent
Actual	5	6	4	4	7	4	5	42.86%	Actual	2	4	1	5	4	5	5	14.29%

Region Based testing the regions																	
Subject Name: <u> N/A </u>													Date: <u> 8/19/2010 </u>				
Subject Student ID: <u> N/A </u>										Subject ID: <u> 012 </u>			Time: <u> 12:30 pm </u>				
Trial 1								Trial 11									
Order	3	5	6	1	4	2	7	Percent	Order	6	7	4	2	5	1	3	Percent
Actual	3	5	6	7	4	2	7	85.71%	Actual	7	1	4	3	4	1	3	42.86%
Trial 2								Trial 12									
Order	1	4	7	2	5	6	3	Percent	Order	1	6	4	7	5	2	3	Percent
Actual	1	7	7	2	2	6	3	71.43%	Actual	5	6	1	5	5	2	4	42.86%
Trial 3								Trial 13									
Order	2	4	5	7	1	6	3	Percent	Order	4	3	7	6	5	2	1	Percent
Actual	6	4	1	7	1	7	7	42.86%	Actual	7	3	3	2	5	7	1	42.86%
Trial 4								Trial 14									
Order	4	3	2	6	7	5	1	Percent	Order	6	5	7	3	4	1	2	Percent
Actual	4	3	2	6	7	5	1	100.00%	Actual	6	5	7	3	4	1	2	100.00%
Trial 5								Trial 15									
Order	2	6	7	3	1	5	4	Percent	Order	6	1	5	2	7	4	3	Percent
Actual	1	2	7	6	4	5	4	57.14%	Actual	6	3	5	5	7	4	3	71.43%
Trial 6								Trial 16									
Order	2	1	7	3	6	4	5	Percent	Order	4	7	6	5	2	3	1	Percent
Actual	5	6	7	2	6	4	1	42.86%	Actual	5	4	2	5	2	3	1	57.14%
Trial 7								Trial 17									
Order	4	2	3	5	6	7	1	Percent	Order	1	4	3	7	5	2	6	Percent
Actual	4	2	2	5	4	7	1	71.43%	Actual	1	4	3	7	2	2	6	100.00%
Trial 8								Trial 18									
Order	3	4	2	1	7	6	5	Percent	Order	6	2	4	5	1	7	3	Percent
Actual	3	4	2	1	1	6	5	85.71%	Actual	3	1	4	5	1	7	3	71.43%
Trial 9								Trial 19									
Order	3	1	2	7	6	5	4	Percent	Order	2	4	6	7	3	5	1	Percent
Actual	3	1	2	7	6	5	5	85.71%	Actual	1	2	6	7	3	5	1	71.43%
Trial 10								Trial 20									
Order	7	1	4	5	6	2	3	Percent	Order	3	7	1	2	5	4	6	Percent
Actual	7	5	4	5	6	2	5	71.43%	Actual	3	2	1	2	5	4	6	85.71%

Region Based testing the regions																	
Subject Name: <u> N/A </u>								Date: <u> 9/9/2010 </u>									
Subject Student ID: <u> N/A </u>								Subject ID: <u> 013 </u>				Time: <u> 3:35 pm </u>					
Trial 1								Trial 11									
Order	6	3	7	5	1	2	4	Percent	Order	7	4	2	6	3	1	5	Percent
Actual	6	3	7	5	1	2	4	100.00%	Actual	7	4	2	6	3	1	5	100.00%
Trial 2								Trial 12									
Order	4	7	1	6	2	3	5	Percent	Order	1	4	3	7	6	2	5	Percent
Actual	4	7	1	6	2	3	5	100.00%	Actual	1	4	3	7	6	2	5	100.00%
Trial 3								Trial 13									
Order	2	3	7	5	1	4	6	Percent	Order	7	2	5	6	4	3	1	Percent
Actual	2	5	7	5	1	4	6	85.71%	Actual	7	6	5	2	4	2	1	57.14%
Trial 4								Trial 14									
Order	1	7	4	6	5	2	3	Percent	Order	1	5	7	2	6	3	4	Percent
Actual	1	7	4	6	5	4	3	85.71%	Actual	2	5	7	2	6	3	4	85.71%
Trial 5								Trial 15									
Order	4	6	7	2	5	1	3	Percent	Order	1	3	7	5	2	6	4	Percent
Actual	4	6	7	2	1	1	2	71.43%	Actual	1	3	7	1	2	2	4	71.43%
Trial 6								Trial 16									
Order	5	3	7	6	2	1	4	Percent	Order	7	2	6	1	3	4	5	Percent
Actual	5	3	4	6	2	1	4	85.71%	Actual	7	2	6	1	3	4	5	100.00%
Trial 7								Trial 17									
Order	3	5	4	6	7	1	2	Percent	Order	7	3	1	5	4	2	6	Percent
Actual	3	5	1	6	7	1	2	85.71%	Actual	7	3	5	5	4	2	6	85.71%
Trial 8								Trial 18									
Order	6	5	2	7	4	3	1	Percent	Order	4	2	1	5	6	7	3	Percent
Actual	6	5	6	7	4	5	1	71.43%	Actual	4	5	1	4	5	7	1	42.86%
Trial 9								Trial 19									
Order	4	6	2	7	3	5	1	Percent	Order	1	7	3	2	5	4	6	Percent
Actual	4	6	2	7	5	2	1	71.43%	Actual	4	7	3	2	5	4	6	85.71%
Trial 10								Trial 20									
Order	5	6	7	4	1	2	3	Percent	Order	3	7	2	1	6	5	4	Percent
Actual	3	6	2	4	2	2	3	57.14%	Actual	3	7	2	1	5	5	5	71.43%

Region Based testing the regions																	
Subject Name: <u> N/A </u>													Date: <u> 10/21/2010 </u>				
Subject Student ID: <u> N/A </u>										Subject ID: <u> 014 </u>			Time: <u> 10:10 am </u>				
Trial 1								Trial 11									
Order	5	1	2	3	4	6	7	Percent	Order	1	7	2	4	6	3	5	Percent
Actual	5	1	2	1	2	1	7	57.14%	Actual	1	7	2	4	6	3	5	100.00%
Trial 2								Trial 12									
Order	6	3	5	2	1	7	4	Percent	Order	4	5	6	3	7	1	2	Percent
Actual	6	3	3	1	1	7	4	71.43%	Actual	4	5	5	1	7	1	2	71.43%
Trial 3								Trial 13									
Order	4	5	2	1	3	6	7	Percent	Order	5	4	1	6	7	2	3	Percent
Actual	1	5	3	1	3	6	2	57.14%	Actual	5	4	1	6	7	2	3	100.00%
Trial 4								Trial 14									
Order	6	7	2	3	4	1	5	Percent	Order	6	3	4	1	2	5	7	Percent
Actual	7	7	2	3	3	1	5	71.43%	Actual	6	3	4	1	2	5	7	100.00%
Trial 5								Trial 15									
Order	1	7	5	6	4	2	3	Percent	Order	4	5	2	7	3	1	6	Percent
Actual	1	7	5	6	1	2	3	85.71%	Actual	6	5	2	7	3	1	6	85.71%
Trial 6								Trial 16									
Order	4	2	5	6	3	1	7	Percent	Order	2	7	6	3	1	4	5	Percent
Actual	5	2	5	6	6	1	2	57.14%	Actual	2	7	2	3	3	4	1	57.14%
Trial 7								Trial 17									
Order	1	7	5	6	4	3	2	Percent	Order	2	6	7	5	3	4	1	Percent
Actual	1	7	5	6	7	5	3	57.14%	Actual	2	6	7	5	3	1	1	85.71%
Trial 8								Trial 18									
Order	6	1	2	5	4	7	3	Percent	Order	5	3	1	7	6	2	4	Percent
Actual	6	1	2	5	3	7	4	71.43%	Actual	5	3	1	7	6	2	4	100.00%
Trial 9								Trial 19									
Order	2	1	5	7	6	4	3	Percent	Order	7	5	6	2	1	4	3	Percent
Actual	2	1	5	7	6	4	3	100.00%	Actual	7	5	6	1	1	4	6	71.43%
Trial 10								Trial 20									
Order	6	1	7	4	2	3	5	Percent	Order	1	4	3	6	7	2	5	Percent
Actual	6	1	4	4	2	3	5	85.71%	Actual	1	4	3	6	7	2	5	100.00%

APPENDIX E – RESULTS FROM THE COMPARISON OF SC, RC, AND RB2 PARADIGMS

Subject Name: N/A
 Student ID: N/A
 Subject ID: 001
 Date: 1/12/2012
 Time:
 Start: 5:30 PM
 End: 7:30 PM
 Signed IRB consent form Yes No

Trial 1		Trial 2		Trial 3	
RBP2	P E B B L E I	RBP2	P E B B L E I	RBP2	P E B B L E I
Level 1	3 1 3 3 2 1 7	Level 1	3 1 3 3 2 1 7	Level 1	3 1 3 3 2 1 7
level 1 act	3 1 3 3 2 1 7	level 1 act	3 1 3 3 2 1 3	level 1 act	3 1 3 2 2 1 7
Level 2	4 1 6 6 4 1 2	Level 2	4 1 6 6 4 1 2	Level 2	4 1 6 6 4 1 2
Level 2 act	4 1 6 6 4 1 2	Level 2 act	4 1 6 6 5 5 1	Level 2 act	4 1 5 6 4 1 2

Trial 1		Trial 2		Trial 3	
RBP2	M X 8 5 + Z &	RBP2	M X 8 5 + Z &	RBP2	M X 8 5 + Z &
Level 1	2 4 5 5 6 4 7	Level 1	2 4 5 5 6 4 7	Level 1	2 4 5 5 6 4 7
level 1 act	2 4 5 5 6 4 7	level 1 act	2 4 5 5 6 4 6	level 1 act	2 4 5 5 6 4 7
Level 2	7 2 6 3 5 5 7	Level 2	7 2 6 3 5 5 7	Level 2	7 2 6 3 5 5 7
Level 2 act	7 2 6 3 5 5 7	Level 2 act	7 2 6 3 5 5 7	Level 2 act	7 2 6 3 5 5 7

Paradigm:	Paradigm #	Trial 1		Trial 2		Trial 3	
		Intended	%	Intended	%	Intended	%
Single Character (SCP)	1	PEBBLE!	100%	PEBBLE!	86%	PEBBLE!	71%
		MX85+Z&	71%	MX85+Z&	86%	MX85+Z&	71%
Row/Column (RCP)	2	Intended	%	Intended	%	Intended	%
		PEBBLE!	71%	PEBBLE!	86%	PEBBLE!	100%
		MX85+Z&	71%	MX85+Z&	86%	MX8&+Y&	71%
Region Based 2 (RBP2)	3	Intended	%	Intended	%	Intended	%
		PEBBLE!	100%	PEBBLE!	57%	PEBBLE!	86%
		MX85+Z&	100%	MX85+Z&	100%	MX85+Z&	100%

Order of Paradigms: 123

Buffer Length [ms]: 800 Number of Flashes: 6 Mode: Copy Spelling Dark Time [ms]: 150
 Male or Female (please circle one) Flash Time [ms]: 100 Number of Channels: 8
 Age: 24 Do you wear corrective lens? Y or N (please circle one)

Subject Name: N/A
Student ID: N/A
Subject ID: 002
Date: 1/13/2012
Time:
Start: 11:45 AM
End: 2:15 PM
Signed IRB consent form Yes No

Trial 1
RBP2
 Level 1
 level 1 act
 Level 2
 Level 2 act
RBP2
 Level 1
 level 1 act
 Level 2
 Level 2 act

P E B B L E I
 3 1 3 3 2 1 7
 3 1 3 3 2 1 4
 4 1 6 6 4 1 2
 1 1 6 6 6 1 2
 M X 8 5 + Z &
 2 4 5 5 6 4 7
 2 4 5 5 7 4 7
 7 2 6 3 5 5 7
 4 2 6 3 5 1 7

Trial 2
RBP2
 Level 1
 level 1 act
 Level 2
 Level 2 act
RBP2
 Level 1
 level 1 act
 Level 2
 Level 2 act

P E B B L E I
 3 1 3 3 2 1 7
 5 1 3 3 2 1 3
 4 1 6 6 4 1 2
 6 4 6 6 4 1 2
 M X 8 5 + Z &
 2 4 5 5 6 4 7
 2 4 5 5 6 4 7
 7 2 6 3 5 5 7
 7 2 5 3 5 5 7

Trial 3
RBP2
 Level 1
 level 1 act
 Level 2
 Level 2 act
RBP2
 Level 1
 level 1 act
 Level 2
 Level 2 act

P E B B L E I
 3 1 3 3 2 1 7
 3 1 4 3 2 1 7
 4 1 6 6 4 1 2
 1 1 6 6 4 1 4
 M X 8 5 + Z &
 2 4 5 5 6 4 7
 2 7 5 5 6 4 7
 7 2 6 3 5 5 7
 7 2 6 3 5 5 7

Paradigm:	Paradigm #	Trial 1	Trial 2	Trial 3
Single Character (SCP)	1	Actual CR1B1E3 MX8Y+Z& 29% 71%	Actual PKBBAE+ MRNO+ZX 57% 43%	Actual AEBXLE! M98R+Z& 71% 71%
Row/Column (RCP)	2	Actual PEBBLE! MX85+Z& 100% 71%	Actual DEBBFEC MX85+Z& 57% 100%	Actual PEBBLE! MV85+T& 100% 71%
Region Based 2 (RBP2)	3	Actual UEBBCE! LX85+K& 71% 71%	Actual BOBBLE! MX75+Z& 71% 86%	Actual UEBBLE# MX85+Z& 71% 100%

Order of Paradigms ___213___
 Buffer Length [ms] 800 Number of Flashes: 6 Mode: Copy Spelling Dark Time [ms]: 150
 Male or Female (please circle one) Flash Time [ms]: 100 Number of Channels: 8
 Age: ___23___ Do you wear corrective lens? Y or N (please circle one)

Subject Name: N/A
Student ID: N/A
Subject ID: 003

Date: 1/13/2012
Time:
Start: 5:00 PM
End: 7:00 PM

Signed IRB consent form Yes No

Trial 1
RBP2
 Level 1
 level 1 act
 Level 2
 Level 2 act

RBP2
 Level 1
 level 1 act
 Level 2
 Level 2 act

P E B B L E I
 3 1 3 3 2 1 7
 3 1 3 3 2 1 7
 4 1 6 6 4 1 2
 4 1 6 6 4 1 2

 M X 8 5 + Z &
 2 4 5 5 6 4 7
 2 4 5 5 6 4 7
 7 2 6 3 5 5 7
 7 2 6 3 5 5 7

Trial 2
RBP2
 Level 1
 level 1 act
 Level 2
 Level 2 act

RBP2
 Level 1
 level 1 act
 Level 2
 Level 2 act

P E B B L E I
 3 1 3 3 2 1 7
 3 1 3 3 2 1 7
 4 1 6 6 4 1 2
 4 1 7 6 4 1 2

 M X 8 5 + Z &
 2 4 5 5 6 4 7
 2 4 5 5 6 4 7
 7 2 6 3 5 5 7
 7 2 6 3 5 5 7

Trial 3
RBP2
 Level 1
 level 1 act
 Level 2
 Level 2 act

RBP2
 Level 1
 level 1 act
 Level 2
 Level 2 act

P E B B L E I
 3 1 3 3 2 1 7
 3 1 3 3 2 1 7
 4 1 6 6 4 1 2
 4 1 6 6 2 1 2

 M X 8 5 + Z &
 2 4 5 5 6 4 7
 2 4 5 5 6 4 7
 7 2 6 3 5 5 7
 7 2 6 3 5 5 7

Paradigm:	Paradigm #	Trial 1	Trial 2	Trial 3
Single Character (SCP)	1	Intended: PEBBLE! Actual: PEBJFE! Intended: MX85+Z& Actual: M3859Z! %: 71%	Intended: PEBBLE! Actual: PESELED Intended: MX85+Z& Actual: V&C7TYH %: 57%	Intended: PEBBLE! Actual: OZ8EMEZ Intended: MX85+Z& Actual: MX85+Z& %: 14%
Row/Column (RCP)	2	Intended: PEBBLE! Actual: PEBBL87 Intended: MX85+Z& Actual: MF8&+Z& %: 71%	Intended: PEBBLE! Actual: PEBBLE! Intended: MX85+Z& Actual: MX25+Z& %: 100%	Intended: PEBBLE! Actual: PEBBFE! Intended: MX85+Z& Actual: SX75+Z& %: 86%
Region Based 2 (RBP2)	3	Intended: PEBBLE! Actual: PEBBLE! Intended: MX85+Z& Actual: MX85+Z& %: 100%	Intended: PEBBLE! Actual: PEVBLE! Intended: MX85+Z& Actual: MX85+Z& %: 86%	Intended: PEBBLE! Actual: PEBBHE! Intended: MX85+Z& Actual: MX85+Z& %: 100%

Order of Paradigms _____ 123 _____

 Buffer Length [ms] 800 Number of Flashes: 6 Mode: Copy Spelling Dark Time [ms]: 150
 Male or Female (please circle one) Flash Time [ms]: 100 Number of Channels: 8
 Age: ____29____ Do you wear corrective lens? Y or N (please circle one)

Subject Name: N/A
Student ID: N/A
Subject ID: 004

Date: 2/15/2012
Time:
Start: 4:00 PM
End: 6:00 PM

Signed IRB consent form Yes No

Trial 1
RBP2
 Level 1
 level 1 act
 Level 2
 Level 2 act

RBP2
 Level 1
 level 1 act
 Level 2
 Level 2 act

P E B B L E I
 3 1 3 3 2 1 7
 1 2 4 2 2 1 7
 4 1 6 6 4 1 2
 3 3 6 2 4 1 6

 M X 8 5 + Z &
 2 4 5 5 6 4 7
 1 2 5 1 6 4 7
 7 2 6 3 5 5 7
 1 2 1 1 5 5 4

Trial 2
RBP2
 Level 1
 level 1 act
 Level 2
 Level 2 act

RBP2
 Level 1
 level 1 act
 Level 2
 Level 2 act

P E B B L E I
 3 1 3 3 2 1 7
 3 1 1 3 2 1 7
 4 1 6 6 4 1 2
 5 7 2 5 4 1 2

 M X 8 5 + Z &
 2 4 5 5 6 4 7
 2 6 5 5 4 4 5
 7 2 6 3 5 5 7
 7 2 7 1 5 5 4

Trial 3
RBP2
 Level 1
 level 1 act
 Level 2
 Level 2 act

RBP2
 Level 1
 level 1 act
 Level 2
 Level 2 act

P E B B L E I
 3 1 3 3 2 1 7
 3 1 3 3 2 1 7
 4 1 6 6 4 1 2
 4 4 2 6 4 3 2

 M X 8 5 + Z &
 2 4 5 5 6 4 7
 2 1 5 5 7 4 7
 7 2 6 3 5 5 7
 4 7 1 1 5 5 4

Paradigm:	Paradigm #	Trial 1	Trial 2	Trial 3
Single Character (SCP)	1	Intended: PEBBLE! Actual: PEBAYEG Intended: MX85+Z& Actual: HP89+Z& %: 57%	Intended: PEBBLE! Actual: QCFBT9D Intended: MX85+Z& Actual: GRRX+V& %: 43%	Intended: PEBBLE! Actual: FLCBAES Intended: MX85+Z& Actual: MM35SHZW %: 29%
Row/Column (RCP)	2	Intended: PEBBLE! Actual: PCBELEY Intended: MX85+Z& Actual: RX25+N& %: 57%	Intended: PEBBLE! Actual: NEBBLEU Intended: MX85+Z& Actual: MX8&9J& %: 71%	Intended: PEBBLE! Actual: PEBBLD& Intended: MX85+Z& Actual: PXX5+Z& %: 71%
Region Based 2 (RBP2)	3	Intended: PEBBLE! Actual: YABGLE% Intended: MX85+Z& Actual: SX33+Z# %: 43%	Intended: PEBBLE! Actual: WIGWLE! Intended: MX85+Z& Actual: MX93+Z# %: 57%	Intended: PEBBLE! Actual: POGBLA! Intended: MX85+Z& Actual: L233+Z# %: 57%

Order of Paradigms _____ 231 _____

 Buffer Length [ms] 800 Number of Flashes: 6 Mode: Copy Spelling Dark Time [ms]: 150
 Male or Female (please circle one) Flash Time [ms]: 100 Number of Channels: 8
 Age: ____21____ Do you wear corrective lens? Y or N (please circle one)

Subject Name: N/A
Student ID: N/A
Subject ID: 005

Date: 2/16/2012
Time:
Start: 11:20 AM
End: 1:20 PM

Signed IRB consent form Yes No

Trial 1
RBP2
 Level 1
 level 1 act
 Level 2
 Level 2 act

RBP2
 Level 1
 level 1 act
 Level 2
 Level 2 act

P E B B L E I
 3 1 3 3 2 1 7
 3 1 3 3 2 1 7
 4 1 6 6 4 1 2
 4 1 6 6 4 1 2

 M X 8 5 + Z &
 2 4 5 5 6 4 7
 2 4 5 5 6 4 7
 7 2 6 3 5 5 7
 6 2 6 3 5 5 7

Trial 2
RBP2
 Level 1
 level 1 act
 Level 2
 Level 2 act

RBP2
 Level 1
 level 1 act
 Level 2
 Level 2 act

P E B B L E I
 3 1 3 3 2 1 7
 3 1 3 3 2 1 7
 4 1 6 6 4 1 2
 4 1 6 6 4 1 2

 M X 8 5 + Z &
 2 4 5 5 6 4 7
 2 4 5 5 6 4 7
 7 2 6 3 5 5 7
 7 2 6 3 5 5 7

Trial 3
RBP2
 Level 1
 level 1 act
 Level 2
 Level 2 act

RBP2
 Level 1
 level 1 act
 Level 2
 Level 2 act

P E B B L E I
 3 1 3 3 2 1 7
 3 4 3 3 2 1 7
 4 1 6 6 4 1 2
 4 1 6 6 4 1 2

 M X 8 5 + Z &
 2 4 5 5 6 4 7
 2 4 5 5 6 4 7
 7 2 6 3 5 5 7
 7 2 3 3 5 5 7

Paradigm:	Paradigm #	Trial 1	Trial 2	Trial 3
Single Character (SCP)	1	Intended PEBBLE! MX85+Z&	Actual PEBBLE! MX8H++&	Intended PEBBLE! MX85+Z&
Row/Column (RCP)	2	Intended PEBBLE! MX85+Z&	Actual PEBBLE! MX85+Z&	Intended PEBBLE! MX85+Z&
Region Based 2 (RBP2)	3	Intended PEBBLE! CX85+Z&	Actual PEBBLE! MX85+Z&	Intended PEBBLE! MX85+Z&

Order of Paradigms _____ 312 _____
 Buffer Length [ms] 800 Number of Flashes: 6 Mode: Copy Spelling Dark Time [ms]: 150
 Male or Female (please circle one) Flash Time [ms]: 100 Number of Channels: 8
 Age: ____21____ Do you wear corrective lens? Y or N (please circle one)

Subject Name: N/A
Student ID: N/A
Subject ID: 006
Date: 2/21/2012
Time:
Start: 4:00 PM
End: 6:15 PM
Signed IRB consent form Yes No

Trial 1
RBP2
 Level 1
 level 1 act
 Level 2
 Level 2 act
RBP2
 Level 1
 level 1 act
 Level 2
 Level 2 act

P E B B L E I
 3 1 3 3 2 1 7
 3 5 7 4 4 6 7
 4 1 6 6 4 1 2
 4 1 7 3 7 1 1
 M X 8 5 + Z &
 2 4 5 5 6 4 7
 2 3 5 3 5 4 7
 7 2 6 3 5 5 7
 1 2 6 4 5 6 7

Trial 2
RBP2
 Level 1
 level 1 act
 Level 2
 Level 2 act
RBP2
 Level 1
 level 1 act
 Level 2
 Level 2 act

P E B B L E I
 3 1 3 3 2 1 7
 3 3 3 3 2 3 7
 4 1 6 6 4 1 2
 4 1 3 6 4 1 2
 M X 8 5 + Z &
 2 4 5 5 6 4 7
 2 1 5 5 6 3 7
 7 2 6 3 5 5 7
 7 2 5 3 5 7 7

Trial 3
RBP2
 Level 1
 level 1 act
 Level 2
 Level 2 act
RBP2
 Level 1
 level 1 act
 Level 2
 Level 2 act

P E B B L E I
 3 1 3 3 2 1 7
 3 2 4 3 4 3 6
 4 1 6 6 4 1 2
 4 1 6 7 4 7 6
 M X 8 5 + Z &
 2 4 5 5 6 4 7
 7 4 5 5 6 4 3
 7 2 6 3 5 5 7
 3 2 2 6 1 7 3

Paradigm:	Paradigm #	Trial 1	Trial 2	Trial 3
Single Character (SCP)	1	Actual: BRBWDR2 Intended: PEBBLE! %: 14%	Actual: +EBB&E! Intended: PEBBLE! %: 71%	Actual: 3WD8LK! Intended: PEBBLE! %: 29%
Row/Column (RCP)	2	Actual: M18KPW& Intended: MX85+Z& %: 43%	Actual: BM7IQB8 Intended: MX85+Z& %: 0%	Actual: C!EFNBW Intended: MX85+Z& %: 0%
Region Based 2 (RBP2)	3	Actual: PEBBLA! Intended: PEBBLE! %: 86%	Actual: 1EBDHE! Intended: PEBBLE! %: 57%	Actual: PEBBLE! Intended: PEBBLE! %: 100%
		Actual: MX85SZ8 Intended: MX85+Z& %: 71%	Actual: MX85+Z! Intended: MX85+Z& %: 86%	Actual: EX85M80 Intended: MX85+Z& %: 43%
		Actual: PEVYME" Intended: PEBBLE! %: 43%	Actual: PEYBLE! Intended: PEBBLE! %: 86%	Actual: PEBVLI% Intended: PEBBLE! %: 57%
		Actual: SZ86+1& Intended: MX85+Z& %: 57%	Actual: MX75+2& Intended: MX85+Z& %: 71%	Actual: DX4802@ Intended: MX85+Z& %: 14%

Order of Paradigms _____ 231 _____
 Buffer Length [ms] 800 Number of Flashes: 6 Mode: Copy Spelling Dark Time [ms]: 150
 Male or Female (please circle one) Flash Time [ms]: 100 Number of Channels: 8
 Age: ____21____ Do you wear corrective lens? Y or N (please circle one)

Subject Name: N/A
Student ID: N/A
Subject ID: 007

Date: 2/22/2012
Time:
Start: 3:15 PM
End: 5:30 PM

Signed IRB consent form Yes No

Trial 1
RBP2
 Level 1
 level 1 act
 Level 2
 Level 2 act

RBP2
 Level 1
 level 1 act
 Level 2
 Level 2 act

P E B B L E I
 3 1 3 3 2 1 7
 3 7 3 3 2 1 7
 4 1 6 6 4 1 2
 4 1 7 6 4 4 2

 M X 8 5 + Z &
 2 4 5 5 6 4 7
 2 4 5 5 6 4 7
 7 2 6 3 5 5 7
 6 2 7 7 5 5 7

Trial 2
RBP2
 Level 1
 level 1 act
 Level 2
 Level 2 act

RBP2
 Level 1
 level 1 act
 Level 2
 Level 2 act

P E B B L E I
 3 1 3 3 2 1 7
 3 5 3 3 2 7 7
 4 1 6 6 4 1 2
 6 1 6 6 5 1 2

 M X 8 5 + Z &
 2 4 5 5 6 4 7
 4 4 5 5 4 7
 7 2 6 3 5 5 7
 7 2 4 3 5 5 7

Trial 3
RBP2
 Level 1
 level 1 act
 Level 2
 Level 2 act

RBP2
 Level 1
 level 1 act
 Level 2
 Level 2 act

P E B B L E I
 3 1 3 3 2 1 7
 3 1 3 3 2 7 7
 4 1 6 6 4 1 2
 5 1 6 6 4 1 2

 M X 8 5 + Z &
 2 4 5 5 6 4 7
 2 4 5 5 6 4 7
 7 2 6 3 5 5 7
 7 2 4 7 5 5 7

Paradigm: Paradigm # Trial 1 Trial 2 Trial 3

Single Character (SCP)	Intended	Actual	%	Intended	Actual	%	Intended	Actual	%
1	PEBBLE!	PV+O&Q!	29%	PEBBLE!	P+BELLS	43%	PEBBLE!	PL&E7D!	29%
	MX85+Z&	OXXZYS&	29%	MX85+Z&	3G857ZO	43%	MX85+Z&	M3UJIT&	29%

Row/Column (RCP)	Intended	Actual	%	Intended	Actual	%	Intended	Actual	%
2	PEBBLE!	PEBBLE!	100%	PEBBLE!	PQBBLE!	86%	PEBBLE!	PEBBLE!	100%
	MX85+Z&	MR85+Z&	86%	MX85+Z&	MX85+ZO	86%	MX85+Z&	MX85+Z&	100%

Region Based 2 (RBP2)	Intended	Actual	%	Intended	Actual	%	Intended	Actual	%
3	PEBBLE!	PEVBLO!	71%	PEBBLE!	BEBFFE!	71%	PEBBLE!	WEBBLE!	86%
	MX85+Z&	CX99+Z&	57%	MX85+Z&	MX65+Z&	86%	MX85+Z&	MX69+Z&	71%

Order of Paradigms _____ 231 _____
 Buffer Length [ms] 800 Number of Flashes: 6 Mode: Copy Spelling Dark Time [ms]: 150
 Male or Female (please circle one) Flash Time [ms]: 100 Number of Channels: 8
 Age: ____22____ Do you wear corrective lens? Y or N (please circle one)

Subject Name: N/A
Student ID: N/A
Subject ID: 008
Date: 2/22/2012
Time:
Start: 7:00 PM
End: 9:00 PM
Signed IRB consent form Yes No

Trial 1
RBP2
 Level 1
 level 1 act
 Level 2
 Level 2 act
RBP2
 Level 1
 level 1 act
 Level 2
 Level 2 act

P E B B L E I
 3 1 3 3 2 1 7
 3 3 3 3 1 2 7
 4 1 6 6 4 1 2
 4 1 2 6 4 1 2
 M X 8 5 + Z &
 2 4 5 5 6 4 7
 2 4 5 5 6 4 7
 7 2 6 3 5 5 7
 7 2 6 3 5 5 7

Trial 2
RBP2
 Level 1
 level 1 act
 Level 2
 Level 2 act
RBP2
 Level 1
 level 1 act
 Level 2
 Level 2 act

P E B B L E I
 3 1 3 3 2 1 7
 3 1 1 3 2 1 7
 4 1 6 6 4 1 2
 4 1 6 6 4 1 4
 M X 8 5 + Z &
 2 4 5 5 6 4 7
 2 1 5 4 3 4 7
 7 2 6 3 5 5 7
 4 3 7 6 5 5 7

Trial 3
RBP2
 Level 1
 level 1 act
 Level 2
 Level 2 act
RBP2
 Level 1
 level 1 act
 Level 2
 Level 2 act

P E B B L E I
 3 1 3 3 2 1 7
 3 1 3 3 2 1 7
 4 1 6 6 4 1 2
 5 1 5 3 4 1 2
 M X 8 5 + Z &
 2 4 5 5 6 4 7
 2 4 5 5 6 4 7
 7 2 6 3 5 5 7
 7 2 7 3 7 5 7

Paradigm:	Paradigm #	Trial 1	Trial 2	Trial 3
Single Character (SCP)	1	Intended: PEBBLE! Actual: PEBBLE! Intended: MX85+Z& Actual: MX85YZ& %: 71% %: 86%	Intended: PEBBLE! Actual: PEBBLE! Intended: MX85+Z& Actual: MQZS+Z+ %: 86% %: 43%	Intended: PEBBLE! Actual: PEBBLE! Intended: MX85+Z& Actual: MX85+Z& %: 86% %: 86%
Row/Column (RCP)	2	Intended: PEBBLE! Actual: PETBLE! Intended: MX85+Z& Actual: MX85SZ& %: 86% %: 86%	Intended: PEBBLE! Actual: PEBBLE! Intended: MX85+Z& Actual: MX85+Z7 %: 100% %: 86%	Intended: PEBBLE! Actual: PEABLEY! Intended: MX85+Z& Actual: MX85+Z& %: 71% %: 100%
Region Based 2 (RBP2)	3	Intended: PEBBLE! Actual: PEBBLE! Intended: MX85+Z& Actual: MX85+Z& %: 86% %: 100%	Intended: PEBBLE! Actual: PEBBLE# Intended: MX85+Z& Actual: LJ98+Z& %: 86% %: 43%	Intended: PEBBLE! Actual: WEWYLE! Intended: MX85+Z& Actual: MX95Z& %: 57% %: 71%

Order of Paradigms _____ 213 _____
 Buffer Length [ms] 800 Number of Flashes: 6 Mode: Copy Spelling Dark Time [ms]: 150
 Male or Female (please circle one) Flash Time [ms]: 100 Number of Channels: 8
 Age: ___22___ Do you wear corrective lens? Y or N (please circle one)

Subject Name: N/A
Student ID: N/A
Subject ID: 009
Date: 2/23/2012
Time:
Start: 12:30 PM
End: 2:30 PM
Signed IRB consent form Yes No

Trial 1
RBP2
 Level 1
 level 1 act
 Level 2
 Level 2 act
RBP2
 Level 1
 level 1 act
 Level 2
 Level 2 act

P E B B L E I
 3 1 3 3 2 1 7
 3 1 3 3 2 1 7
 4 1 6 6 4 1 2
 4 1 6 6 7 1 2
 M X 8 5 + Z &
 2 4 5 5 6 4 7
 2 4 5 5 6 4 7
 7 2 6 3 5 5 7
 7 2 6 3 3 5 7

Trial 2
RBP2
 Level 1
 level 1 act
 Level 2
 Level 2 act
RBP2
 Level 1
 level 1 act
 Level 2
 Level 2 act

P E B B L E I
 3 1 3 3 2 1 7
 3 1 3 3 2 1 7
 4 1 6 6 4 1 2
 4 1 1 6 4 1 2
 M X 8 5 + Z &
 2 4 5 5 6 4 7
 2 4 5 5 6 4 7
 7 2 6 3 5 5 7
 7 2 6 3 1 5 2

Trial 3
RBP2
 Level 1
 level 1 act
 Level 2
 Level 2 act
RBP2
 Level 1
 level 1 act
 Level 2
 Level 2 act

P E B B L E I
 3 1 3 3 2 1 7
 3 1 3 3 2 1 7
 4 1 6 6 4 1 2
 4 1 6 6 4 1 2
 M X 8 5 + Z &
 2 4 5 5 6 4 7
 2 4 5 5 6 4 7
 7 2 6 3 5 5 7
 4 1 6 3 5 5 7

Paradigm:	Paradigm #	Trial 1	Trial 2	Trial 3
Single Character (SCP)	1	Intended: PEBBLE! Actual: PEBBLD! Intended: MX85+Z& Actual: MW5PHZ& %: 86%	Intended: PEBBLE! Actual: PMBBL8O Intended: MX85+Z& Actual: MX8PMZ5 %: 57%	Intended: PEBBLE! Actual: PEBBLW! Intended: MX85+Z& Actual: MX85PZ& %: 86%
Row/Column (RCP)	2	Intended: PEBBLE! Actual: PEBBLE! Intended: MX85+Z& Actual: MX85+Z& %: 100%	Intended: PEBBLE! Actual: PEBBLE! Intended: MX85+Z& Actual: MX85+Z& %: 100%	Intended: PEBBLE! Actual: PEBBLE! Intended: MX85+Z& Actual: MX85+Z& %: 100%
Region Based 2 (RBP2)	3	Intended: PEBBLE! Actual: PEBBME! Intended: MX85+Z& Actual: MX85*Z& %: 86%	Intended: PEBBLE! Actual: PEUBLE! Intended: MX85+Z& Actual: MX85OZ! %: 71%	Intended: PEBBLE! Actual: PEBBLE! Intended: MX85+Z& Actual: LK85+Z& %: 71%

Order of Paradigms _____ 312 _____
 Buffer Length [ms] 800 Number of Flashes: 6 Mode: Copy Spelling Dark Time [ms]: 150
 Male or Female (please circle one) Flash Time [ms]: 100 Number of Channels: 8
 Age: ___22___ Do you wear corrective lens? Y or N (please circle one)

Subject Name: N/A
Student ID: N/A
Subject ID: 010

Date: 2/23/2012
Time:
Start: 4:15 PM
End: 6:15 PM

Signed IRB consent form Yes No

Trial 1
RBP2
 Level 1
 level 1 act
 Level 2
 Level 2 act

RBP2
 Level 1
 level 1 act
 Level 2
 Level 2 act

P E B B L E I
 3 1 3 3 2 1 7
 3 1 3 3 2 1 7
 4 1 6 6 4 1 2
 4 3 3 6 4 1 7

 M X 8 5 + Z &
 2 4 5 5 6 4 7
 2 4 5 5 3 4 7
 7 2 6 3 5 5 7
 7 2 6 3 5 5 7

Trial 2
RBP2
 Level 1
 level 1 act
 Level 2
 Level 2 act

RBP2
 Level 1
 level 1 act
 Level 2
 Level 2 act

P E B B L E I
 3 1 3 3 2 1 7
 3 7 3 3 2 1 1
 4 1 6 6 4 1 2
 4 1 4 6 4 1 2

 M X 8 5 + Z &
 2 4 5 5 6 4 7
 2 4 5 5 6 4 3
 7 2 6 3 5 5 7
 5 2 6 3 5 5 7

Trial 3
RBP2
 Level 1
 level 1 act
 Level 2
 Level 2 act

RBP2
 Level 1
 level 1 act
 Level 2
 Level 2 act

P E B B L E I
 3 1 3 3 2 1 7
 6 1 3 3 2 1 3
 4 1 6 6 4 1 2
 1 4 6 6 4 1 2

 M X 8 5 + Z &
 2 4 5 5 6 4 7
 1 5 5 2 6 7 2
 7 2 6 3 5 5 7
 3 6 3 1 3 5 7

Paradigm: Paradigm # Trial 1 Trial 2 Trial 3

Single Character (SCP)	Intended	Actual	%	Intended	Actual	%	Intended	Actual	%
1	PEBBLE!	S\8QNO	0%	PEBBLE!	KCQ3SVY	0%	PEBBLE!	O7B5CO5	14%
	MX85+Z&	B9KM/SLM	0%	MX85+Z&	NA2MXPX	0%	MX85+Z&	JFWHLR	0%

Row/Column (RCP)	Intended	Actual	%	Intended	Actual	%
2	PEBBLE!	PEBBLE!	100%	PEBBLE!	PEIEL82	43%
	MX85+Z&	M385+ZZ	71%	MX85+Z&	MX8Z9ZU	57%

Region Based 2 (RBP2)	Intended	Actual	%	Intended	Actual	%
3	PEBBLE!	PAYBLE&	57%	PEBBLE!	PEBBLE!	86%
	MX85+Z&	MX85+Z&	100%	MX85+Z&	FX85+Z&	86%

Order of Paradigms _____ 231 _____

Buffer Length [ms] 800 Number of Flashes: 6 Mode: Copy Spelling Dark Time [ms]: 150
 Male or Female (please circle one) Flash Time [ms]: 100 Number of Channels: 8
 Age: 27 Do you wear corrective lens? Y or N (please circle one)
 Comments: EEG LOOKED FINE FOR THE S/C PARADIGM BUT SUBJECT STILL HAD VERY LOW MARKS

Subject Name: N/A
Student ID: N/A
Subject ID: 011

Date: 2/24/2012
Time:
Start: 9:45 AM
End: 11:45 AM

Signed IRB consent form Yes No

Trial 1
RBP2
 Level 1 P E B B L E I
 Level 1 act 3 1 3 3 2 1 7
 Level 2 3 1 3 3 2 1 7
 Level 2 act 4 1 6 6 4 1 2
 Level 2 act 4 1 6 6 1 1 2

Trial 2
RBP2
 Level 1 P E B B L E I
 Level 1 act 3 1 3 3 2 1 7
 Level 2 3 1 3 3 2 1 7
 Level 2 act 4 1 6 6 4 1 2
 Level 2 act 4 1 6 6 4 1 2

Trial 3
RBP2
 Level 1 P E B B L E I
 Level 1 act 3 1 3 3 2 1 7
 Level 2 3 1 3 3 2 1 7
 Level 2 act 4 1 6 6 4 1 2
 Level 2 act 4 1 6 6 4 1 2

Paradigm: Paradigm # Trial 1 Trial 2 Trial 3

Single Character (SCP) 1
Intended PEBBLE!
Actual PEEBL2!
% 71%
Intended MX85+Z&
Actual MX&5+X&
% 71%

Row/Column (RCP) 2
Intended PEBBLE!
Actual PESBLEZ
% 71%
Intended MX85+Z&
Actual GXX59Z7
% 43%

Region Based 2 (RBP2) 3
Intended PEBBLE!
Actual PEBBSE!
% 86%
Intended MX85+Z&
Actual MX85+Z&
% 100%

Order of Paradigms _____ 312 _____

Buffer Length [ms] 800 **Number of Flashes:** 6 **Mode:** Copy Spelling **Dark Time [ms]:** 150
Male or **Female** (please circle one) **Flash Time [ms]:** 100 **Number of Channels:** 8
Age: ____21____ **Do you wear corrective lens?** **Y** or **N** (please circle one)

Subject Name: N/A
Student ID: N/A
Subject ID: 012
Date: 2/24/2012
Time:
Start: 4:15 PM
End: 6:30 PM
Signed IRB consent form Yes No

Trial 1
RBP2
 Level 1
 level 1 act
 Level 2
 Level 2 act
RBP2
 Level 1
 level 1 act
 Level 2
 Level 2 act

P E B B L E I
 3 1 3 3 2 1 7
 3 1 6 4 7 1 7
 4 1 6 6 4 1 2
 7 1 7 3 5 6 2
 M X 8 5 + Z &
 2 4 5 5 6 4 7
 2 3 5 5 6 4 7
 7 2 6 3 5 5 7
 7 3 6 3 5 2 7

Trial 2
RBP2
 Level 1
 level 1 act
 Level 2
 Level 2 act
RBP2
 Level 1
 level 1 act
 Level 2
 Level 2 act

P E B B L E I
 3 1 3 3 2 1 7
 3 1 6 4 7 1 7
 4 1 6 6 4 1 2
 4 1 6 6 7 2 2
 M X 8 5 + Z &
 2 4 5 5 6 4 7
 7 5 5 4 6 4 7
 7 2 6 3 5 5 7
 7 3 6 3 5 5 4

Trial 3
RBP2
 Level 1
 level 1 act
 Level 2
 Level 2 act
RBP2
 Level 1
 level 1 act
 Level 2
 Level 2 act

P E B B L E I
 3 1 3 3 2 1 7
 3 1 4 3 4 1 5
 4 1 6 6 4 1 2
 7 7 5 3 6 1 2
 M X 8 5 + Z &
 2 4 5 5 6 4 7
 7 7 5 3 6 1 2
 7 2 6 3 5 5 7
 2 6 7 2 3 6 6

Paradigm:	Paradigm #	Trial 1	Trial 2	Trial 3
Single Character (SCP)	1	Intended: PEBBLE! Actual: 8E+BJE! Intended: MX85+Z& Actual: SX8E7HZ	Intended: PEBBLE! Actual: SK5OL8Q Intended: MX85+Z& Actual: YU8G5I+	Intended: PEBBLE! Actual: U8VAG7V Intended: MX85+Z& Actual: SVZPAGK
Row/Column (RCP)	2	Intended: PEBBLE! Actual: NEFFJ!! Intended: MX85+Z& Actual: S95X8V5	Intended: PEBBLE! Actual: VK8B3E3 Intended: MX85+Z& Actual: QILD2V+	Intended: PEBBLE! Actual: OPG5RQV Intended: MX85+Z& Actual: NX9&I98
Region Based 2 (RBP2)	3	Intended: PEBBLE! Actual: VEYFR! Intended: MX85+Z& Actual: MJ85+X&	Intended: PEBBLE! Actual: PEBBM!! Intended: MX85+Z& Actual: MJ85+Z#	Intended: PEBBLE! Actual: VIWYCE! Intended: MX85+Z& Actual: MK86+Z&

Order of Paradigms _____ 321 _____
 Buffer Length [ms] 800 Number of Flashes: 6 Mode: Copy Spelling Dark Time [ms]: 150
 Male or Female (please circle one) Flash Time [ms]: 100 Number of Channels: 8
 Age: ____24____ Do you wear corrective lens? Y or N (please circle one)

Subject Name: N/A
Student ID: N/A
Subject ID: 013

Date: 2/25/2012
Time:
Start: 1:45 PM
End: 3:45 PM

Signed IRB consent form Yes No

Trial 1
RBP2
 Level 1
 level 1 act
 Level 2
 Level 2 act

RBP2
 Level 1
 level 1 act
 Level 2
 Level 2 act

P E B B L E I
 3 1 3 3 2 1 7
 7 2 1 3 2 1 7
 4 1 6 6 4 1 2
 4 3 1 2 4 7 5

 M X 8 5 + Z &
 2 4 5 5 6 4 7
 4 7 5 6 6 7
 7 2 6 3 5 5 7
 1 5 6 2 3 3 5

Trial 2
RBP2
 Level 1
 level 1 act
 Level 2
 Level 2 act

RBP2
 Level 1
 level 1 act
 Level 2
 Level 2 act

P E B B L E I
 3 1 3 3 2 1 7
 3 7 7 1 6 3 7
 4 1 6 6 4 1 2
 4 6 6 4 3 1 6

 M X 8 5 + Z &
 2 4 5 5 6 4 7
 4 3 5 1 6 6 3
 7 2 6 3 5 5 7
 3 6 1 1 5 1 7

Trial 3
RBP2
 Level 1
 level 1 act
 Level 2
 Level 2 act

RBP2
 Level 1
 level 1 act
 Level 2
 Level 2 act

P E B B L E I
 3 1 3 3 2 1 7
 7 7 3 4 4 1 1
 4 1 6 6 4 1 2
 4 1 4 6 1 1 7

 M X 8 5 + Z &
 2 4 5 5 6 4 7
 3 4 1 5 3 5 5
 7 2 6 3 5 5 7
 3 2 4 5 2 7 7

Paradigm:	Paradigm #	Trial 1	Trial 2	Trial 3
Single Character (SCP)	1	Intended: PEBBLE! Actual: UAL7IU&+I&1XET %: 0%	Intended: PEBBLE! Actual: PJB8GV9 %: 29%	Intended: PEBBLE! Actual: D997GPC %: 0%
Row/Column (RCP)	2	Intended: MX85+Z& Actual: ZQB1RGF %: 14%	Intended: MX85+Z& Actual: HIBQOKC %: 14%	Intended: MX85+Z& Actual: PE1CEZO %: 29%
Region Based 2 (RBP2)	3	Intended: MX85+Z& Actual: PAUGLI\$ %: 29%	Intended: MX85+Z& Actual: PRBPDE% %: 43%	Intended: MX85+Z& Actual: PEPBSE& %: 57%
		Intended: MX85+Z& Actual: SZ84*J\$ %: 14%	Intended: MX85+Z& Actual: D133+K& %: 29%	Intended: MX85+Z& Actual: DX67/2& %: 29%

Order of Paradigms _____ 312 _____

 Buffer Length [ms] 800 Number of Flashes: 6 Mode: Copy Spelling Dark Time [ms]: 150
 Male or Female (please circle one) Flash Time [ms]: 100 Number of Channels: 8
 Age: ____22____
 Do you wear corrective lens? Y or N (please circle one)

Subject Name: N/A
Student ID: N/A
Subject ID: 014
Date: 2/25/2012
Time:
Start: 4:30 PM
End: 6:30 PM
Signed IRB consent form Yes No

Trial 1
RBP2
 Level 1
 level 1 act
 Level 2
 Level 2 act
RBP2
 Level 1
 level 1 act
 Level 2
 Level 2 act

P E B B L E I
 3 1 3 3 2 1 7
 3 1 3 3 2 1 7
 4 1 6 6 4 1 2
 4 1 6 6 4 4 2
 M X 8 5 + Z &
 2 4 5 5 6 4 7
 2 4 5 5 6 7 7
 7 2 6 3 5 5 7
 7 2 1 4 6 5 2

Trial 2
RBP2
 Level 1
 level 1 act
 Level 2
 Level 2 act
RBP2
 Level 1
 level 1 act
 Level 2
 Level 2 act

P E B B L E I
 3 1 3 3 2 1 7
 3 1 3 3 2 1 7
 4 1 6 6 4 1 2
 4 1 5 6 4 6 2
 M X 8 5 + Z &
 2 4 5 5 6 4 7
 2 7 5 5 6 4 7
 7 2 6 3 5 5 7
 5 2 6 3 5 5 4

Trial 3
RBP2
 Level 1
 level 1 act
 Level 2
 Level 2 act
RBP2
 Level 1
 level 1 act
 Level 2
 Level 2 act

P E B B L E I
 3 1 3 3 2 1 7
 3 1 3 3 2 5 7
 4 1 6 6 4 1 2
 4 1 6 6 4 1 6
 M X 8 5 + Z &
 2 4 5 5 6 4 7
 1 4 5 5 6 4 6
 7 2 6 3 5 5 7
 3 2 1 3 5 5 7

Paradigm:	Paradigm #	Trial 1	Trial 2	Trial 3
Single Character (SCP)	1	Intended: PEBBLE! Actual: PEBBLE! Intended: MX85+Z& Actual: MX85+Z& %: 100%	Intended: PEBBLE! Actual: PEBBLE! Intended: MX85+Z& Actual: MZ85+Z& %: 86%	Intended: PEBBLE! Actual: PEBBLE! Intended: MX85+Z& Actual: MW85+Z& %: 100%
Row/Column (RCP)	2	Intended: PEBBLE! Actual: ODBALK! Intended: MX85+Z& Actual: GW7&+B+ %: 43%	Intended: PEBBLE! Actual: PEABLE! Intended: MX85+Z& Actual: GX&5+Z& %: 86%	Intended: PEBBLE! Actual: PEBBKE! Intended: MX85+Z& Actual: MX85+NB& %: 86%
Region Based 2 (RBP2)	3	Intended: PEBBLE! Actual: PEBBLO! Intended: MX85+Z& Actual: MX36.ZI %: 86%	Intended: PEBBLE! Actual: PEWBRL! Intended: MX85+Z& Actual: FX85+Z# %: 71%	Intended: PEBBLE! Actual: PEBBLE# Intended: MX85+Z& Actual: DX35+Z& %: 71%

Order of Paradigms _____ 231 _____
 Buffer Length [ms] 800 Number of Flashes: 6 Mode: Copy Spelling Dark Time [ms]: 150
 Male or Female (please circle one) Number of Channels: 8
 Age: ____24____ Do you wear corrective lens? Y or N (please circle one)

Subject Name: N/A
Student ID: N/A
Subject ID: 015

Date: 3/27/2012
Time:
Start: 1:15 PM
End: 3:30 PM

Signed IRB consent form Yes No

Trial 1
RBP2
 Level 1 P E B B L E I
 level 1 act 3 1 3 3 2 1 7
 Level 2 1 1 1 3 2 1 2
 Level 2 act 4 1 6 6 4 1 2
 Level 2 act 4 1 6 6 4 3 2

Trial 2
RBP2
 Level 1 P E B B L E I
 level 1 act 3 1 3 3 2 1 7
 Level 2 3 4 3 4 1 1 7
 Level 2 act 4 1 6 6 4 1 2
 Level 2 act 2 2 6 6 4 4 2

Trial 3
RBP2
 Level 1 P E B B L E I
 level 1 act 3 1 3 3 2 1 7
 Level 2 3 4 3 4 1 1 7
 Level 2 act 4 1 6 6 4 1 2
 Level 2 act 4 1 7 6 4 6 2

Paradigm: Paradigm # Trial 1 Trial 2 Trial 3

Single Character (SCP) 1 Intended PEBBLE! Actual QEBNEE1 % 43%
 Intended MX85+Z& Actual PUMSDZB % 29%
 Intended PEBBLE! Actual 8359LLU % 14%
 Intended MX85+Z& Actual IXM+XIE % 14%

Row/Column (RCP) 2 Intended PEBBLE! Actual PEBBLE! % 71%
 Intended MX85+Z& Actual +X85Y5& % 57%
 Intended PEBBLE! Actual PETALK1 % 43%
 Intended MX85+Z& Actual AX8B+Z5 % 57%

Region Based 2 (RBP2) 3 Intended PEBBLE! Actual PEBBLA! % 86%
 Intended MX85+Z& Actual MX95+Z@ % 71%
 Intended PEBBLE! Actual GTBBLO! % 57%
 Intended MX85+Z& Actual MX35+Q& % 71%

Order of Paradigms _____ 231 _____
 Buffer Length [ms] 800 Number of Flashes: 6 Mode: Copy Spelling Dark Time [ms]: 150
 Male or Female (please circle one) Flash Time [ms]: 100 Number of Channels: 8
 Age: ____21____ Do you wear corrective lens? Y or N (please circle one)

Subject Name: N/A
Student ID: N/A
Subject ID: 016
Date: 3/27/2012
Time:
Start: 3:35 PM
End: 5:55 PM
Signed IRB consent form Yes No

Trial 1
RBP2
 Level 1
 level 1 act
 Level 2
 Level 2 act
RBP2
 Level 1
 level 1 act
 Level 2
 Level 2 act

P E B B L E I
 3 1 3 3 2 1 7
 3 1 3 3 4 1 7
 4 1 6 6 4 1 2
 4 1 6 6 4 1 2
 M X 8 5 + Z &
 2 4 5 5 6 4 7
 2 4 5 5 6 4 7
 7 2 6 3 5 5 7
 7 2 6 3 5 5 7

Trial 2
RBP2
 Level 1
 level 1 act
 Level 2
 Level 2 act
RBP2
 Level 1
 level 1 act
 Level 2
 Level 2 act

P E B B L E I
 3 1 3 3 2 1 7
 3 1 3 3 2 1 7
 4 1 6 6 4 1 2
 4 2 6 6 4 1 4
 M X 8 5 + Z &
 2 4 5 5 6 4 7
 2 4 5 5 6 4 7
 7 2 6 3 5 5 7
 7 2 6 3 5 5 7

Trial 3
RBP2
 Level 1
 level 1 act
 Level 2
 Level 2 act
RBP2
 Level 1
 level 1 act
 Level 2
 Level 2 act

P E B B L E I
 3 1 3 3 2 1 7
 3 1 3 3 2 1 7
 4 1 6 6 4 1 2
 4 1 6 6 4 1 2
 M X 8 5 + Z &
 2 4 5 5 6 4 7
 2 4 5 5 6 4 7
 7 2 6 3 5 5 7
 7 2 6 3 5 5 7

Paradigm:	Paradigm #	Trial 1	Trial 2	Trial 3
Single Character (SCP)	1	Actual: PEBBRE& Intended: YXR+Z& %: 71%	Actual: HEBBQE! Intended: MX85+Z& %: 100%	Actual: PEBXBE2 Intended: MX15FA& %: 57%
Row/Column (RCP)	2	Actual: PEBBLE! Intended: MX85+Z7 %: 100%	Actual: PEBBLE! Intended: MX85+Z& %: 100%	Actual: PEBBLE! Intended: MX85+Z& %: 100%
Region Based 2 (RBP2)	3	Actual: PEBBLE! Intended: MX85+Z& %: 100%	Actual: PTBBLE# Intended: MX85+Z& %: 71%	Actual: PEBBLE! Intended: MX857Z& %: 100%

Order of Paradigms _____ 321 _____
 Buffer Length [ms] 800 Number of Flashes: 6 Mode: Copy Spelling Dark Time [ms]: 150
 Male or Female (please circle one) Flash Time [ms]: 100 Number of Channels: 8
 Age: ____22____ Do you wear corrective lens? Y or N (please circle one)

Subject Name: N/A
Student ID: N/A
Subject ID: 017

Date: 3/27/2012
Time:
Start: 6:00 PM
End: 8:15 PM

Signed IRB consent form Yes No

Trial 1
RBP2
 Level 1
 level 1 act
 Level 2
 Level 2 act

RBP2
 Level 1
 level 1 act
 Level 2
 Level 2 act

P E B B L E I
 3 1 3 3 2 1 7
 3 1 3 3 2 1 7
 4 1 6 6 4 1 2
 4 1 6 3 4 1 2

 M X 8 5 + Z &
 2 4 5 5 6 4 7
 2 4 5 2 4 7
 7 2 6 3 5 5 7
 7 2 7 3 5 3 7

Trial 2
RBP2
 Level 1
 level 1 act
 Level 2
 Level 2 act

RBP2
 Level 1
 level 1 act
 Level 2
 Level 2 act

P E B B L E I
 3 1 3 3 2 1 7
 3 1 3 3 2 1 7
 4 1 6 6 4 1 2
 4 1 1 6 4 4 3

 M X 8 5 + Z &
 2 4 5 5 6 4 7
 2 4 5 5 6 4 7
 7 2 6 3 5 5 7
 7 2 6 3 4 5 7

Trial 3
RBP2
 Level 1
 level 1 act
 Level 2
 Level 2 act

RBP2
 Level 1
 level 1 act
 Level 2
 Level 2 act

P E B B L E I
 3 1 3 3 2 1 7
 3 1 3 3 2 1 7
 4 1 6 6 4 1 2
 4 1 6 6 4 2 2

 M X 8 5 + Z &
 2 4 5 5 6 4 7
 2 4 5 5 6 4 7
 7 2 6 3 5 5 7
 7 2 6 3 5 5 7

Paradigm: Paradigm # Trial 1 Trial 2 Trial 3

Single Character (SCP) 1
Intended PEBBLE!
Actual PEKFLQ!
% 57%
Intended MX85+Z&
Actual MXDXZ10
% 29%

Row/Column (RCP) 2
Intended PEBBLE!
Actual PEEBLE!
% 86%
Intended MX85+Z&
Actual MF&5+Z&
% 71%

Region Based 2 (RBP2) 3
Intended PEBBLE!
Actual PEBYLE!
% 86%
Intended MX85+Z&
Actual MX95+J&
% 71%

Actual 9EBXLEE
% 57%
Intended PEBBLE!
Actual MO85BZ7
% 57%
Intended MX85+Z&
Actual PCBDLD!
% 57%
Intended MX85+Z&
Actual MX85MZ&
% 86%
Intended PEBBLE!
Actual PEUBLO@
% 57%
Intended MX85+Z&
Actual MX85+Z&
% 86%
Intended PEBBLE!
Actual PEBBLT!
% 86%
Intended MX85+Z&
Actual MX85+Z&
% 100%

Order of Paradigms _____ 231 _____
 Buffer Length [ms] 800 Number of Flashes: 6 Mode: Copy Spelling Dark Time [ms]: 150
 Male or Female (please circle one) Number of Channels: 8
 Age: _____ 27 _____
 Do you wear corrective lens? Y or N (please circle one)

Subject Name: N/A
Student ID: N/A
Subject ID: 018
Date: 3/27/2012
Time:
Start: 8:30 PM
End: 10:50 PM
Signed IRB consent form Yes No

Trial 1
RBP2
 Level 1
 level 1 act
 Level 2
 Level 2 act
RBP2
 Level 1
 level 1 act
 Level 2
 Level 2 act

P E B B L E I
 3 1 3 3 2 1 7
 7 1 1 2 6 7 7
 4 1 6 6 4 1 2
 2 6 4 7 5 2 4
 M X 8 5 + Z &
 2 4 5 5 6 4 7
 6 6 3 3 4 7 2
 7 2 6 3 5 5 7
 5 2 2 1 7 1 3

Trial 2
RBP2
 Level 1
 level 1 act
 Level 2
 Level 2 act
RBP2
 Level 1
 level 1 act
 Level 2
 Level 2 act

P E B B L E I
 3 1 3 3 2 1 7
 7 5 5 1 3 7 5
 4 1 6 6 4 1 2
 5 2 3 2 2 1 1
 M X 8 5 + Z &
 2 4 5 5 6 4 7
 2 6 1 6 2 4 1
 7 2 6 3 5 5 7
 3 1 6 4 6 7 1

Trial 3
RBP2
 Level 1
 level 1 act
 Level 2
 Level 2 act
RBP2
 Level 1
 level 1 act
 Level 2
 Level 2 act

P E B B L E I
 3 1 3 3 2 1 7
 4 6 5 7 1 5 6
 4 1 6 6 4 1 2
 6 1 6 3 5 5 5
 M X 8 5 + Z &
 2 4 5 5 6 4 7
 1 6 3 3 3 4 6
 7 2 6 3 5 5 7
 3 7 5 6 2 7 3

Paradigm:	Paradigm #	Trial 1	Trial 2	Trial 3
Single Character (SCP)	1	Intended: PEBBLE! Actual: PEB8+E7 Intended: MX85+Z& Actual: ML9Z5JL %: 57% Intended: PEBBLE! Actual: W+VHNXO %: 0% Intended: MX85+Z& Actual: SC&TSVX %: 0%	Intended: PEBBLE! Actual: W+VHNXO Intended: MX85+Z& Actual: SC&TSVX %: 0% Intended: PEBBLE! Actual: R&MCUW+ %: 0% Intended: MX85+Z& Actual: TR9ER3& %: 14%	Intended: PEBBLE! Actual: LI9PHO2 Intended: MX85+Z& Actual: Z9O53M1 %: 0% Intended: PEBBLE! Actual: &3MKDJW %: 0% Intended: MX85+Z& Actual: Q598O1P %: 0%
Row/Column (RCP)	2	Intended: PEBBLE! Actual: +JNE!F3 Intended: MX85+Z& Actual: AQS8W8O %: 0% Intended: PEBBLE! Actual: PEBBLE! %: 0% Intended: MX85+Z& Actual: MX85+Z& %: 0%	Intended: PEBBLE! Actual: PEBBLE! Intended: MX85+Z& Actual: TR9ER3& %: 14%	Intended: PEBBLE! Actual: &3MKDJW Intended: MX85+Z& Actual: Q598O1P %: 0%
Region Based 2 (RBP2)	3	Intended: PEBBLE! Actual: GRPVFJ# Intended: MX85+Z& Actual: FX43?K@ %: 14%	Intended: PEBBLE! Actual: WTYGHE" Intended: MX85+Z& Actual: DX86.2" %: 14%	Intended: PEBBLE! Actual: BEBYFN\$ Intended: MX85+Z& Actual: D278/2@ %: 29% Intended: PEBBLE! Actual: D278/2@ %: 0%

Order of Paradigms _____123_____

Buffer Length [ms] 800 Number of Flashes: 6 Mode: Copy Spelling Dark Time [ms]: 150
 Male or Female (please circle one) Flash Time [ms]: 100 Number of Channels: 8
 Age: _____24_____ Do you wear corrective lens? Y or N (please circle one)

Comments: EEG LOOKED FINE, SUBJECT JUST DID POORLY

Subject Name: N/A
Student ID: N/A
Subject ID: 019

Date: 3/28/2012
Time:
Start: 9:20 AM
End: 11:30 AM

Signed IRB consent form Yes No

Trial 1		Trial 2		Trial 3	
RBP2	PEBBLE I	RBP2	PEBBLE I	RBP2	PEBBLE I
Level 1	3 1 3 3 2 1 7	Level 1	3 1 3 3 2 1 7	Level 1	3 1 3 3 2 1 7
Level 1 act	3 1 3 3 2 1 7	Level 1 act	3 1 3 3 2 1 7	Level 1 act	3 1 3 3 2 1 7
Level 2	4 1 6 6 4 1 2	Level 2	4 1 6 6 4 1 2	Level 2	4 1 6 6 4 1 2
Level 2 act	4 1 6 6 4 1 2	Level 2 act	4 1 6 6 4 1 2	Level 2 act	4 1 6 6 4 1 2

Trial 1		Trial 2		Trial 3	
RBP2	PEBBLE I	RBP2	PEBBLE I	RBP2	PEBBLE I
Level 1	2 4 5 5 6 4 7	Level 1	2 4 5 5 6 4 7	Level 1	2 4 5 5 6 4 7
Level 1 act	2 4 5 5 6 4 7	Level 1 act	2 4 5 5 6 4 7	Level 1 act	2 4 5 5 6 4 7
Level 2	7 2 6 3 5 5 7	Level 2	7 2 6 3 5 5 7	Level 2	7 2 6 3 5 5 7
Level 2 act	7 2 6 3 5 5 7	Level 2 act	7 2 6 3 5 5 7	Level 2 act	7 2 6 3 5 5 7

Trial 1		Trial 2		Trial 3	
RBP2	PEBBLE I	RBP2	PEBBLE I	RBP2	PEBBLE I
Level 1	2 4 5 5 6 4 7	Level 1	2 4 5 5 6 4 7	Level 1	2 4 5 5 6 4 7
Level 1 act	2 4 5 5 6 4 7	Level 1 act	2 4 5 5 6 4 7	Level 1 act	2 4 5 5 6 4 7
Level 2	7 2 6 3 5 5 7	Level 2	7 2 6 3 5 5 7	Level 2	7 2 6 3 5 5 7
Level 2 act	7 2 6 3 5 5 7	Level 2 act	7 2 6 3 5 5 7	Level 2 act	7 2 6 3 5 5 7

Paradigm:	Paradigm #	Trial 1	Trial 2	Trial 3							
Single Character (SCP)	1	Intended	PEBBLE!	Actual	PEBBLE!	Intended	PEBBLE!	Actual	5EBBLE!	%	86%
		Intended	MX85+Z&	Actual	MX85+Z&	Intended	MX85+Z&	Actual	MX85+Z&	%	100%
		Intended	PEBBLE!	Actual	PEBBLE!	Intended	PEBBLE!	Actual	PEBBLE!	%	100%
Row/Column (RCP)	2	Intended	PEBBLE!	Actual	PEBBLE!	Intended	PEBBLE!	Actual	PEBBLE!	%	100%
		Intended	MX85+Z&	Actual	MX85+Z&	Intended	MX85+Z&	Actual	MX85+Z&	%	100%
		Intended	PEBBLE!	Actual	PEBBLE!	Intended	PEBBLE!	Actual	PEBBLE!	%	100%
Region Based 2 (RBP2)	3	Intended	PEBBLE!	Actual	PEBBLE!	Intended	PEBBLE!	Actual	PEBBLE!	%	100%
		Intended	MX85+Z&	Actual	MX85+Z&	Intended	MX85+Z&	Actual	MX85+Z&	%	100%
		Intended	PEBBLE!	Actual	PEBBLE!	Intended	PEBBLE!	Actual	PEBBLE!	%	100%

Order of Paradigms _____ 231 _____
 Buffer Length [ms] 800 Number of Flashes: 6 Mode: Copy Spelling Dark Time [ms]: 150
 Male or Female (please circle one) Flash Time [ms]: 100 Number of Channels: 8
 Age: _____ 23 _____ Do you wear corrective lens? Y or N (please circle one)

Subject Name: N/A
Student ID: N/A
Subject ID: 020

Date: 3/28/2012
Time:
Start: 12:45 PM
End: 2:50 PM

Signed IRB consent form Yes No

Trial 1
RBP2
 Level 1
 level 1 act
 Level 2
 Level 2 act

RBP2
 Level 1
 level 1 act
 Level 2
 Level 2 act

P E B B L E I
 3 1 3 3 2 1 7
 3 1 3 3 2 1 7
 4 1 6 6 4 1 2
 4 1 6 3 4 1 2

 M X 8 5 + Z &
 2 4 5 5 6 4 7
 2 4 5 2 4 7
 7 2 6 3 5 5 7
 7 2 6 3 5 5 7

Trial 2
RBP2
 Level 1
 level 1 act
 Level 2
 Level 2 act

RBP2
 Level 1
 level 1 act
 Level 2
 Level 2 act

P E B B L E I
 3 1 3 3 2 1 7
 3 1 3 3 2 1 7
 4 1 6 6 4 1 2
 4 1 6 6 4 1 2

 M X 8 5 + Z &
 2 4 5 5 6 4 7
 2 4 5 5 6 4 7
 7 2 6 3 5 5 7
 7 2 6 3 5 5 7

Trial 3
RBP2
 Level 1
 level 1 act
 Level 2
 Level 2 act

RBP2
 Level 1
 level 1 act
 Level 2
 Level 2 act

P E B B L E I
 3 1 3 3 2 1 7
 3 1 3 3 2 1 7
 4 1 6 6 4 1 2
 4 1 6 6 4 1 2

 M X 8 5 + Z &
 2 4 5 5 6 4 7
 2 4 5 5 6 4 7
 7 2 6 3 5 5 7
 7 2 6 3 5 5 7

Paradigm: Paradigm # Trial 1 Trial 2 Trial 3

Single Character (SCP) 1
Intended PEBBLE!
Actual PEBBLE5
% 86%
Intended MX85+Z&
Actual LX85+Z&
% 86%

Row/Column (RCP) 2
Intended PEBBLE!
Actual PEBFE!
% 71%
Intended MX85+Z&
Actual MX85+Z&
% 100%

Region Based 2 (RBP2) 3
Intended PEBBLE!
Actual PEBYLE!
% 86%
Intended MX85+Z&
Actual MX85+Z&
% 100%

Order of Paradigms _____ 213 _____

Buffer Length [ms] 800 **Number of Flashes:** 6 **Mode:** Copy Spelling **Dark Time [ms]:** 150
Male or **Female** (please circle one) **Flash Time [ms]:** 100 **Number of Channels:** 8
Age: ____22____ **Do you wear corrective lens?** Y or N (please circle one)

Subject Name: N/A
Student ID: N/A
Subject ID: 021

Date: 3/29/2012
Time:
Start: 2:40 PM
End: 4:50 PM

Signed IRB consent form Yes No

Trial 1
RBP2
 Level 1
 level 1 act
 Level 2
 Level 2 act

RBP2
 Level 1
 level 1 act
 Level 2
 Level 2 act

P E B B L E I
 3 1 3 3 2 1 7
 6 4 6 3 2 1 7
 4 1 6 6 4 1 2
 4 2 2 6 4 1 2

 M X 8 5 + Z &
 2 4 5 5 6 4 7
 2 4 5 5 1 2 7
 7 2 6 3 5 5 7
 2 2 2 3 5 5 7

Trial 2
RBP2
 Level 1
 level 1 act
 Level 2
 Level 2 act

RBP2
 Level 1
 level 1 act
 Level 2
 Level 2 act

P E B B L E I
 3 1 3 3 2 1 7
 3 1 3 3 2 1 7
 4 1 6 6 4 1 2
 4 1 6 6 2 1 3

 M X 8 5 + Z &
 2 4 5 5 6 4 7
 6 4 5 5 2 4 7
 7 2 6 3 5 5 7
 7 2 6 3 7 5 7

Trial 3
RBP2
 Level 1
 level 1 act
 Level 2
 Level 2 act

RBP2
 Level 1
 level 1 act
 Level 2
 Level 2 act

P E B B L E I
 3 1 3 3 2 1 7
 3 1 3 3 2 1 7
 4 1 6 6 4 1 2
 4 6 6 6 4 5 1

 M X 8 5 + Z &
 2 4 5 5 6 4 7
 2 4 5 5 2 4 7
 7 2 6 3 5 5 7
 7 2 7 3 3 5 3

Paradigm:	Paradigm #	Trial 1	Trial 2	Trial 3
Single Character (SCP)	1	Intended: PEBBLE! Actual: PKB28X8 %: 29%	Intended: PEBBLE! Actual: 8UBXSBZ %: 14%	Intended: PEBBLE! Actual: REFHMEH %: 29%
Row/Column (RCP)	2	Intended: PEBBLE! Actual: MX85+Z& %: 14%	Intended: PEBBLE! Actual: YXKV5ZK %: 29%	Intended: PEBBLE! Actual: IX9EZI& %: 29%
Region Based 2 (RBP2)	3	Intended: PEBBLE! Actual: HX45+Z& %: 71%	Intended: PEBBLE! Actual: MX85GZU %: 71%	Intended: PEBBLE! Actual: MX9T+B& %: 57%

Order of Paradigms _____ 213 _____
 Buffer Length [ms] 800 Number of Flashes: 6 Mode: Copy Spelling Dark Time [ms]: 150
 Male or Female (please circle one) Flash Time [ms]: 100 Number of Channels: 8
 Age: ___19___ Do you wear corrective lens? Y or N (please circle one)

Subject Name: N/A
Student ID: N/A
Subject ID: 022

Date: 3/29/2012
Time:
Start: 5:00 PM
End: 7:15 PM

Signed IRB consent form Yes No

Trial 1		Trial 2		Trial 3	
RBP2	PEBBLE I	RBP2	PEBBLE I	RBP2	PEBBLE I
Level 1	3 1 3 3 2 1 7	Level 1	3 1 3 3 2 1 7	Level 1	3 1 3 3 2 1 7
Level 1 act	1 6 3 2 2 4 1	level 1 act	3 1 3 3 2 1 7	level 1 act	3 1 3 3 2 1 7
Level 2	4 1 6 6 4 1 2	Level 2	4 1 6 6 4 1 2	Level 2	4 1 6 6 4 1 2
Level 2 act	1 3 7 4 2 4 7	Level 2 act	4 1 6 6 4 1 2	Level 2 act	4 1 6 6 4 1 2

Trial 1		Trial 2		Trial 3	
RBP2	PEBBLE I	RBP2	PEBBLE I	RBP2	PEBBLE I
Level 1	2 4 5 5 6 4 7	Level 1	2 4 5 5 6 4 7	Level 1	2 4 5 5 6 4 7
Level 1 act	2 4 5 5 6 4 7	level 1 act	2 4 5 5 6 4 7	level 1 act	2 4 5 5 6 4 7
Level 2	7 2 6 3 5 5 7	Level 2	7 2 6 3 5 5 7	Level 2	7 2 6 3 5 5 7
Level 2 act	7 2 6 3 5 5 7	Level 2 act	7 2 6 3 5 5 7	Level 2 act	7 2 6 3 5 5 7

Trial 1		Trial 2		Trial 3	
RBP2	PEBBLE I	RBP2	PEBBLE I	RBP2	PEBBLE I
Level 1	2 4 5 5 6 4 7	Level 1	2 4 5 5 6 4 7	Level 1	2 4 5 5 6 4 7
Level 1 act	2 4 5 5 6 4 7	level 1 act	2 4 5 5 6 4 7	level 1 act	2 4 5 5 6 4 7
Level 2	7 2 6 3 5 5 7	Level 2	7 2 6 3 5 5 7	Level 2	7 2 6 3 5 5 7
Level 2 act	7 2 6 3 5 5 7	Level 2 act	7 2 6 3 5 5 7	Level 2 act	7 2 6 3 5 5 7

Paradigm:	Paradigm #	Trial 1		Trial 2		Trial 3	
Single Character (SCP)		Intended	Actual	%	Intended	Actual	%
1		PEBBLE!	PEBBLE!	100%	PEBBLE!	PEBBLE!	100%
		MX85+Z&	MX85+Z&	100%	MX8H+Z&	MX85+Z&	86%
2		Intended	Actual	%	Intended	Actual	%
		PEBBLE!	PEBBLE!	100%	PEBBLE!	PEBYLK!	71%
		MX85+Z&	MX85+Z&	100%	MX85+Z&	NX8&&Z+	43%
3		Intended	Actual	%	Intended	Actual	%
		PEBBLE!	UAVPKO&	0%	PEBBLE!	PEBBLE!	100%
		MX85+Z&	MX85+Z&	100%	MX85+Z&	MX85+Z&	100%

Order of Paradigms _____ 231 _____
 Buffer Length [ms] 800 Number of Flashes: 6 Mode: Copy Spelling Dark Time [ms]: 150
 Male or Female (please circle one) Flash Time [ms]: 100 Number of Channels: 8
 Age: _____ 21 Do you wear corrective lens? Y or N (please circle one)
 Comment: TRIAL 1 RBP2 AN ELECTRODE LOST CONNECTION ONLY FOR WORD PEBBLE!, IT WAS FIXED FOR MX85+Z&

Subject Name: N/A
Student ID: N/A
Subject ID: 023

Date: 3/30/2012
Time:
Start: 8:20 AM
End: 10:25 AM

Signed IRB consent form Yes No

	Trial 1	Trial 2	Trial 3	P E B B L E I	P E B B L E I	P E B B L E I
RBP2	RBP2	RBP2	RBP2	3 1 3 3 2 1 7	3 1 3 3 2 1 7	3 1 3 3 2 1 7
Level 1	Level 1	Level 1	Level 1	3 1 3 3 2 1 7	3 1 3 3 2 1 7	3 1 3 3 2 1 7
Level 1 act	level 1 act	level 1 act	level 1 act	3 2 3 3 2 1 7	3 1 3 3 2 1 7	3 1 3 7 2 1 7
Level 2	Level 2	Level 2	Level 2	4 1 6 6 4 1 2	4 1 6 6 4 1 2	4 1 6 6 4 1 2
Level 2 act	Level 2 act	Level 2 act	Level 2 act	4 1 6 6 4 1 2	4 1 4 6 4 2 2	4 1 6 6 4 1 2
RBP2	RBP2	RBP2	RBP2	M X 8 5 + Z &	M X 8 5 + Z &	M X 8 5 + Z &
Level 1	Level 1	Level 1	Level 1	2 4 5 5 6 4 7	2 4 5 5 6 4 7	2 4 5 5 6 4 7
Level 1 act	level 1 act	level 1 act	level 1 act	2 4 5 5 6 4 7	2 4 5 5 6 4 7	2 4 5 5 4 4 7
Level 2	Level 2	Level 2	Level 2	7 2 6 3 5 5 7	7 2 6 3 5 5 7	7 2 6 3 5 5 7
Level 2 act	Level 2 act	Level 2 act	Level 2 act	7 2 6 3 5 5 7	7 2 6 3 5 5 7	1 2 6 3 5 5 7

Paradigm:	Paradigm #	Trial 1	Trial 2	Trial 3
Single Character (SCP)	1	Intended PEBBLE! MX85+Z&	Intended PEBBLE! MX85+Z&	Intended PEBBLE! MX85+Z&
		Actual PEBBLE! MX85+Z&	Actual PE&LE! FX85+Z&	Actual PEBBLE! 8X85+Z&
		% 100%	% 100%	% 71% 86%
Row/Column (RCP)	2	Intended PEBBLE! MX85+Z&	Intended PEBBLE! MX85+Z&	Intended PEBBLE! MX85+Z&
		Actual P8BBLE! MX85+Z&	Actual PEBZLE! MX859Z&	Actual PEBDLE! MX85+Z&
		% 86%	% 86%	% 86%
Region Based 2 (RBP2)	3	Intended PEBBLE! MX85+Z&	Intended PEBBLE! MX85+Z&	Intended PEBBLE! MX85+Z&
		Actual PEBBLE! MX85+Z&	Actual PEPBLT! MX85+Z&	Actual PEBBLE! SX85+Z&
		% 100%	% 100%	% 71% 100%

Order of Paradigms _____ 231 _____
 Buffer Length [ms] 800 Number of Flashes: 6 Mode: Copy Spelling Dark Time [ms]: 150
 Male or Female (please circle one) Flash Time [ms]: 100 Number of Channels: 8
 Age: _____ 22 _____
 Do you wear corrective lens? Y or N (please circle one)

APPENDIX F – INFORMED CONSENT

Informed Consent

Research Project Title: Brain-Computer Interface (BCI)

Researchers: Dr. Reza Fazel-Rezai, Scott Gavett, Zachary Wygant, Setare Amiri, Christopher Cunningham

This consent form, a copy of which will be left with you for your records and reference, is only part of the process of informed consent. It should give you the basic idea of what the research is about and what your participation will involve. If you would like more detail about something mentioned here, or information not included here, you should feel free to ask. Please take the time to read this carefully and to understand any accompanying information.

a. Purpose of the research:

The purpose of this study is to spell the characters / numbers using BCI speller. This will be accomplished by recording electroencephalogram (EEG) signals (brain signals) from a control group in a normal, everyday setting on a predetermined computer and running the program called p300 based BCI speller, and will be monitored by qualified professionals (University of North Dakota faculty). This research will help determine the speed and accuracy of a speller program based on p300 potentials as well as provides a new visual paradigm towards brain-computer interface research. The overall accuracy and speed of typing would be increased based on this research and beneficial to the people with disabilities to spell faster and less hectic way.

b. Research procedures:

Before starting the test you should sit on a chair in front of a computer screen and we will explain the experimental process to you as well as the tasks you should perform before the test. The task is to simply looking at the seven regions consisting of seven different sets of letters, characters and numbers, while each character set / region is being flashed or intensified for a particular amount of time. Later, we place the electrode cap on your head and the experiment begins whenever you confirm that you are completely comfortable and ready to begin

Participant's initial _____

Page 1 of 4

testing. During the experiment, the characters/ letters which you want to spell will be flashed on a computer screen distributed over seven regions, in a random sequence, and you will count how many times your particular character set flashes. Meanwhile, your brain signals are captured and transferred to the computer for further analysis. There are only four variations of these tests, each one resulting in a minimum duration of 20-30 minutes. The tests are carried out until the last character set flashes on the screen. The preparation time for the instruments takes about 10 – 15 minutes and the whole procedure takes about 90 – 120 minutes. Before and after the experiments you would be asked to complete a questionnaire form which includes multiple choice questions and questions regarding the comfort level during the experiment and any other suggestions you may have to improve the process. The questionnaire form should take approximately 5 – 10 minutes to be answered. The questionnaire explores the strength and weakness of the experiment from the user's point of view and it gives us the scope of improvement in a very short span of time. However, you are not obligated to complete the questionnaire form or the experiment. You may inform us to stop the test and let you exit the laboratory under any circumstances. Furthermore, in the case where the data is corrupt, your decision to retest is voluntary.

c. Risks and Benefits:

In this experiment the brain signals are recorded and transferred to the computer. This process will be done using "g.tec P300 Spelling Device with g.USBamp and Simulink V2.09a." (www.gtec.at/) hardware and software which have been guaranteed to protect subjects from all types of power related hazards. Very minor risks are involved in this study. After completing a segment of testing, you may feel fatigued, drowsy, claustrophobic and or frustrated. On the other hand, this research has the benefit of improving the accuracy and speed of the spelling device for paraplegic persons.

d. Recording devices:

In this study, we will use the g.tec's newest high-end and high performance active electrode system for non-invasive electrophysiological derivations called g.GAMMAbox® which collects your brain signal activity during testing. These signals will be stored on a computer's hard disk anonymously and will be analyzed later.

Participant's initial _____

Page 2 of 4

e. Assurance of Confidentiality:

In this experiment, the data including the recorded signals and questionnaires will be collected and stored separately in confidential and safe place at our laboratory and advisor's office for a minimum of three years. Your information will never be shared anywhere unless with your written permission.

We have one computer in our laboratory located in Harrington Hall 120 D specifically for our research purpose where the digital data will be stored. This computer is password-protected and nobody has access to it except the main researchers. The paper forms including the letters of consent and questionnaires will be kept safely in a cabinet (which is locked by the faculty advisor, Dr. Reza Fazel) located in the primary investigator's office. Our lab is also safely equipped by a key entry with limited access.

The title of data will be the date and the time of running the experiment. However, in case of giving the feedback we need to know whose subject the data associates with. For this purpose, we will specify the subject's name corresponding to the data in a different file and store it somewhere in our password-protected and absolutely safe computer.

All of the data will be completely destroyed at the end of the research. However, they will be kept at least for a minimum of 3 years. Data means paper forms and digital raw data which will be shredded by a paper shredder and will respectively be erased from the computer and only the results will be kept. Results, on the other hand, only include the final outcome of the research, the number of subjects, their average age and their gender.

f. Feedback

We can provide you the results of the experiment upon your request after analyzing the data. It is not possible to give you any feedback immediately after the test. In case of need of feedback, you may complete the "feedback request" form to request a summary of the results of your experiment. The feedback will be printed on paper with the "University of North Dakota" letterhead.

g. Assurance of Voluntary Participation

Participant's initial _____

Page 3 of 4

Your participation in this research is voluntary. Therefore, you can withdraw from the project at anytime without any consequence. You can contact us via one of the emails mentioned below to withdraw from the test any time prior to the experiment. Furthermore, you can stop the administration of the test in the middle of it through verbal communication to the supervising researcher.

Your signature on this form indicates that you have understood, to your satisfaction, the information regarding participation in the research project and agree to participate as a subject. You are free to withdraw from the study at any time, and /or refrain from answering any questions you prefer to omit, without prejudice or consequence. Your continued participation should be as informed as your initial consent, so you should feel free to ask for clarification or new information throughout your participation. If you have any questions or concerns, please contact the principal researcher, Dr. Reza Fazel-Rezai:

Reza Fazel-Rezai, Ph.D., EIT, IEEE Senior Member
Assistant Professor
Address: Department of Electrical Engineering
Upton Hall II Room 160 N
243 Centennial Drive Stop 7165
Grand Forks, ND 58202
Email: rezafazel@mail.und.edu
URL: <http://www.ee.und.edu/html/research/biomed.html>
Phone: 1-701-777-3368

This research has been approved by the University of North Dakota Institutional Review Board (IRB). If you have any concerns or complaints about this project you may contact the above-named person or the IRB Secretariat at (701) 777-4279. A copy of this consent form has been given to you to keep for your records and reference.

Participant's Signature _____ Date _____

Researcher and/or Delegate's Signature _____ Date _____

Participant's initial _____

APPENDIX G – BCI TEST PLAN

BCI Test plan

Have subject read and sign the consent form and fill out the first half of the questionnaire.

1. Put EEG cap on subject and plug in the electrodes
 - 1.A. FPZ goes to GND
 - 1.B. Ear clip goes to right mastoid
 - 1.C. Fz goes to Channel 1
 - 1.D. Cz goes to Channel 2
 - 1.E. P3 goes to Channel 3
 - 1.F. Pz goes to Channel 4
 - 1.G. P4 goes to Channel 5
 - 1.H. PO7 goes to Channel 6
 - 1.I. Oz goes to Channel 7
 - 1.J. PO8 goes to Channel 8
2. Use abrasive gel and Q-tips in each electrode
3. Use the conductive gel from the syringe to put gel under the electrodes
4. Open MATLAB
5. Locate the 8 channel RC paradigm and open the file
 - 5.A. Make sure the settings are correct
 - 5.A.i. Double click on the Signal processing box and check to see if the following are correct
 - 5.A.i.a. Buffer length [ms] – 800ms
 - 5.A.i.b. Number of flashes - 6
 - 5.A.i.c. Number of channels – 8
 - 5.A.i.d. Classification method – Linear Discrimination Analysis
 - 5.A.ii. Double click on the RowCol Character Speller box and check to see if the following are correct
 - 5.A.ii.a. Mode – Copy Spelling
 - 5.A.ii.b. Flash time [ms] – 100
 - 5.A.ii.c. Dark time [ms] – 150

5.B. Click on the start simulation button

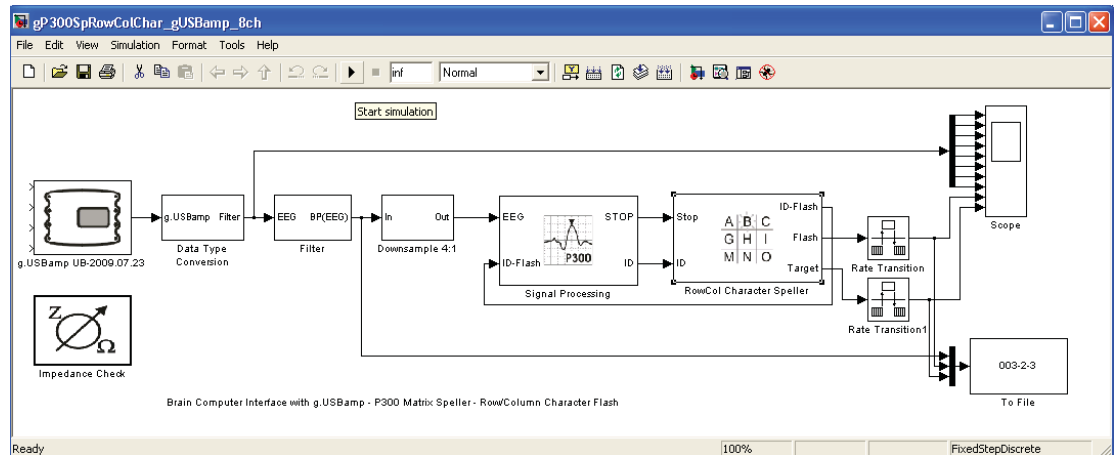

5.C. Click on the characters to spell the word ‘WATER’ or ‘LUCAS’ (these words are for calibration only)

5.D. Click ‘START’

5.E. Have the subject try not to blink too often or grind their teeth this interferes with the EEG, have the subject sit 1 meter from the computer screen

5.F. Show the subject their EEG and show them what happens when they blink and grind their teeth. (this also is the time to see that all the electrodes have a good connection)

5.G. For this calibration period have the subject spell the word ‘WATER’ and ‘LUCAS’ three times then you will load the .mat file for the calibration process.

5.H. Type in ‘gbsanalyze’

5.H.i. File >> Load Data >> 0xx-t.mat

5.H.ii. Sampling rate [Hz] – 256

5.H.iii. User >> P300_LDA_MultiFile_Batch_8ch_256Hz

5.H.iv. User >> P300_LDA_SingleFile_Batch_8ch_256Hz

5.H.v. Wait for the files to load then close the window

6. Type in randperm(3) into MATLAB

6.A. Record the order of paradigms of the record sheet

7. Locate the correct paradigm and make sure the settings are correct

7.A. Type in the first word ‘PEBBLE!’ then start the test

7.B. Record what was actually spelt

7.B.i. If the RB2 paradigm make sure to record the regions that were selected these can be found after the word is spelt in the main MATLAB command window

7.C. After the two words have been spelt ‘PEBBLE!’ and ‘MX85+Z&’ then stop the paradigm by clicking the end simulation button.

7.D. Change the mat file name

7.D.i. The mat files should all read 0xx-1-1, 0xx-1-2, 0xx-1-3, 0xx-2-1, 0xx-2-2, 0xx-2-3, 0xx-3-1, 0xx-3-2, 0xx-3-3

- 7.D.ii. The file format is subject ID – paradigm number – trial number
- 7.E. After each word is tested three times for the paradigm have the subject fill out one of the Subject questionnaires.
- 7.F. Open up next paradigm
8. Repeat this until all paradigms are tested
- After each paradigm have the subject fill out the subject questionnaire
 - At the end of the testing have the subject fill out the second half of the questionnaire and have him/her sign it
 - Make sure all papers are filled out and put them in the subject's folder
 - Clean the EEG cap and let it dry for the next use

Location of MATLAB files for testing

C:\Documents and Settings\Admin\My
Documents\MATLAB\gP300SpSingleChar_gUSBamp_8ch_region1.mdl
C:\Documents and Settings\Admin\My
Documents\MATLAB\gP300_8ch\gP300SpSingleChar_gUSBamp_8ch.mdl
C:\Documents and Settings\Admin\My
Documents\MATLAB\gP300_8ch\gP300SpRowColChar_gUSBamp_8ch.mdl

REFERENCES

- [1] "MedicineNet," 27 April 2011. [Online]. Available: <http://www.medterms.com/script/main/art.asp?articlekey=7785>.
- [2] "Genetics Home Reference," 27 February 2011. [Online]. Available: <http://ghr.nlm.nih.gov/glossary=myelinsheath>.
- [3] W. A. MacKay and H. L. Atwood, *Essentials of neurophysiology*, Toronto: B.C. Decker, 1989.
- [4] D. S. Auld and R. Robitaille, "Glial Cells and Neurotransmission," *Neuron*, vol. 40, no. 2, pp. 389-400, 2003.
- [5] S. Sanei and J. A. Chambers, *EEG Signal Processing*, Cardiff University, UK: John Wiley & Sons, 2007.
- [6] L. F. Haas, "Hans Berger (1873–1941), Richard Caton (1842–1926), and electroencephalography," *Journal of Neurology, Neurosurgery & Psychiatry*, vol. 74, no. 1, 2003.
- [7] K. X. Charand, "Hyper Physics," 2002. [Online]. Available: <http://hyperphysics.phy-astr.gsu.edu/hbase/biology/actpot.html>.
- [8] T. W. Picton, "The P300 wave of the human event-related potential," *Journal of Clinical Neurophysiology*, vol. 9, no. 4, pp. 456-479, 1992.
- [9] R. J. Jr., "On the neural generators of the P300 component of the event-related potential," *Psychophysiology*, vol. 30, no. 1, pp. 90-97, 1993.
- [10] P. J. L. Howard and A. Starr, "Effects of Age on the P300 Component of the Event-related Potential From Auditory Stimuli: Peak Definition, Variation, and Measurement," *The Journal of Gerontology*, vol. 40, no. 6, pp. 721-726, 1985.
- [11] J. Wolpaw, N. Birbaumer, W. Heetderks, D. McFarland, P. Peckham, G. Schalk, E. Donchin, L. Quatrano, C. Robinson and T. Vaughan, "Brain-computer interface technology: a review of the first international meeting," *IEEE Transactions on Rehabilitation Engineering*, vol. 8, no. 2, pp. 164-173, June 2000.
- [12] J. J. Vidal, "Toward Direct Brain-Computer Communication," *Annual Review of Biophysics and Bioengineering*, vol. 2, pp. 157-180, 1973.
- [13] L. A. Farwell and E. Donchin, "Talking off the top of your head: toward a mental prosthesis utilizing event-related brain potentials," *Electroencephalography and Clinical Neurophysiology*, vol. 70, no. 6, pp. 510-523, 1988.

- [14] C. Guger, S. Daban, E. Sellers, C. Holzner, G. Krausz, R. Carabalona, F. Gramatica and G. Edlinger, "How many people are able to control a P300-based brain-computer interface (BCI)?," *Neuroscience Letters*, vol. 462, no. 1, pp. 94-98, 2009.
- [15] E. W. Sellers, D. J. Krusienski, D. J. McFarland, T. M. Vaughan and J. R. Wolpaw, "A P300 event-related potential brain-computer interface (BCI): The effects of matrix size and inter stimulus interval on performance," *Biological Psychology*, vol. 73, no. 3, pp. 242-252, 2006.
- [16] M. Salvaris and F. Sepulveda, "Visual modifications on the P300 speller BCI paradigm," *Journal of Neural Engineering*, vol. 6, no. 4, 2009.
- [17] R. Fazel-Rezai, "P300-Based Speller Brain-Computer Interface," in *Recent Advances in Biomedical Engineering*, InTech, 2009, pp. 137-148.
- [18] G. G. Celesia and M. Brigell, "Event-related potentials," *Current Opinion in Neurology & Neurosurgery*, vol. 5, no. 5, 1992.
- [19] M. Rangaswamy and B. Porjesz, "From Event-Related Potentials to Oscillations," *National Institute on Alcohol Abuse and Alcoholism (NIAAA)*, pp. 238-242.
- [20] S. Debener, S. Makeig, A. Delorme and A. K. Engel, "What is novel in the novelty oddball paradigm? Functional significance of the novelty P3 event-related potential as revealed by independent component analysis," *Brain Research. Cognitive Brain Research*, pp. 309-321, 2005.
- [21] G. Townsend, B. K. LaPallo, C. B. Boulay, D. J. Krusienski, G. E. Frye, C. K. Hauser, N. E. Schwartz, T. M. Vaughan, J. R. Wolpaw and E. W. Sellers, "A novel P300-based brain-computer interface stimulus presentation paradigm: moving beyond rows and columns," *Clinical Neurophysiology*, 2010.
- [22] R. Fazel-Rezai and K. Abhari, "A region-based P300 speller for brain-computer interface," *Canadian Journal of Electrical and Computer Engineering*, vol. 34, no. 3, pp. 81-85, 2009.
- [23] R. Fazel-Rezai, S. Gavett, W. Ahmad, A. Rabbi and E. Schneider, "A Comparison Among Several P300 Brain-Computer Interface Speller Paradigms," *Journal of Clinical EEG & Neuroscience*, vol. 42, no. 4, pp. 209-213, 2011.
- [24] R. Fazel-Rezai, "Human Error in P300 Speller Paradigm for Brain-Computer Interface," in *International Conference of the IEEE Engineering in Medicine and Biology Society*, Lyon, 2007.
- [25] R. Fazel-Rezai and W. Ahmad, "P300-based Brain-Computer Interface Paradigm Design," in *Recent Advances in Brain-Computer Interface Systems*, InTech, 2011.
- [26] J. L. M. Perez and A. B. Cruz, "Linear Discriminant Analysis on Brain Computer Interface," *Intelligent Signal Processing*, pp. 1-6, 2007.
- [27] H. Mirghasemi, R. Fazel-Rezai and M. B. Shamsollahi, "Analysis of p300 classifiers in brain computer interface speller," in *International Conference of IEEE Engineering in Medicine and Biology Society*, New York, 2006.
- [28] M. Kaper, P. Meinicke, U. Grosse-kathoefer, T. Lingner and H. Ritter, "BCI competition 2003-data set IIb: support vector machines for the P300 speller paradigm," *IEEE Transactions on Biomedical Engineering*, vol. 51, no. 6, pp. 1073 - 1076, 2004.

- [29] B. Blankertz, F. Popescu, M. Krauledat, S. Fazli, M. Tangermann and K.-R. Müller, "Challenges for Brain-Computer Interface Research for Human-Computer Interaction Applications," in *ACM SIGCHI*, Florence, Italy, 2008.
- [30] "Brain Tag," [Online]. Available: <http://www.mat.ucsb.edu/~g.legrady/academic/courses/10f200a/bt/background.htm>.
- [31] C. Feng, Y. Jiang and S. He, "Horizontal and vertical asymmetry in visual spatial crowding effects," *Journal of Vision*, vol. 7, no. 2, pp. 1-10, 2007.
- [32] J. T. Cacioppo, R. E. Petty, M. E. Losch and S. L. Crites, "Psychophysiological approaches to attitudes: Detecting affective dispositions when people won't say, can't say, or don't even know," in *Persuasion: Psychological insights and perspectives*, New York, Allyn & Bacon, 1994, pp. 43-69.
- [33] L. A. Farwell and S. S. Smith, "Using Brain MERMER Testing to Detect Knowledge Despite Efforts to Conceal," *Journal of Forensic Sciences*, vol. 46, no. 1, pp. 1-9, 2001.
- [34] C. Guger, C. Holzner, C. Grönegress, G. Edlinger and M. Slater, "Brain-Computer Interface for Virtual Reality Control," in *European Symposium on Artificial Neural Networks*, Belgium, 2009.
- [35] D. J. Krusienski, E. W. Sellers, F. Cabestaing, S. Bayouth, D. J. McFarland, T. M. Vaughan and J. R. Wolpaw, "A comparison of classification techniques for the P300 speller," *Journal of Neural Engineering*, vol. 3, no. 4, pp. 299-305, 2006.
- [36] U. Herwig, P. Satrapi and C. Schönfeldt-Lecuona, "Using the International 10-20 EEG System for Positioning of Transcranial Magnetic Stimulation," *Brain Topography*, vol. 16, no. 2, pp. 95-99, 2003.
- [37] "UND Institutional Review Board," UND, [Online]. Available: <http://und.edu/research/research-economic-development/institutional-review-board/>.