



5-1988

# A Study of the Effects of Polyethylene Glycol on Interactions Between Glycolytic Enzymes and F-Actin, and Among Glycolytic Enzymes

Julie L. Walsh

Follow this and additional works at: <https://commons.und.edu/theses>

 Part of the [Psychology Commons](#)

---

## Recommended Citation

Walsh, Julie L., "A Study of the Effects of Polyethylene Glycol on Interactions Between Glycolytic Enzymes and F-Actin, and Among Glycolytic Enzymes" (1988). *Theses and Dissertations*. 821.  
<https://commons.und.edu/theses/821>

This Dissertation is brought to you for free and open access by the Theses, Dissertations, and Senior Projects at UND Scholarly Commons. It has been accepted for inclusion in Theses and Dissertations by an authorized administrator of UND Scholarly Commons. For more information, please contact [zeinebyousif@library.und.edu](mailto:zeinebyousif@library.und.edu).

A STUDY OF THE EFFECTS OF POLYETHYLENE GLYCOL ON  
INTERACTIONS BETWEEN GLYCOLYTIC ENZYMES AND F-ACTIN,  
AND AMONG GLYCOLYTIC ENZYMES

by

Julie L. Walsh

Bachelor of Arts, Carleton College, 1983

A Dissertation

Submitted to the Graduate Faculty

of the

University of North Dakota

in partial fulfillment of the requirements

for the degree of

Doctor of Philosophy

Grand Forks, North Dakota

May

1988

T1988  
W168

This dissertation submitted by Julie L. Walsh in partial fulfillment of the requirements of the Degree of Doctor of Philosophy from the University of North Dakota has been read by the Faculty Advisor Committee under whom the work has been done, and is hereby approved.

---

(Chairperson)

---

---

---

---

---

This dissertation meets the standards for appearance and conforms to the style and format requirements of the Graduate School of the University of North Dakota, and is hereby approved.

---

Dean of the Graduate School

Permission

Title A Study of the Effects of Polyethylene Glycol on  
the Interactions Between Glycolytic Enzymes and F-  
Actin and Among the Glycolytic Enzymes

Department Biochemistry and Molecular Biology

Degree Doctor of Philosophy

In presenting this dissertation in partial fulfillment of the requirements for a graduate degree from the University of North Dakota, I agree that the Library of the University shall make it freely available for inspection. I further agree that permission for extensive copying for scholarly purposes may be granted by the professor who supervised my dissertation work or, in his absence, by the Chairman of the Department or the Dean of the Graduate School. It is understood that any copying or publication or other use of this dissertation or part thereof for financial gain shall not be allowed without my written permission. It is also understood that due recognition shall be given to me and to the University of North Dakota in any scholarly use which may be made of any material in my dissertation.

Signature \_\_\_\_\_

Date \_\_\_\_\_

## TABLE OF CONTENTS

LIST OF ILLUSTRATIONS . . . . .	vi
LIST OF TABLES . . . . .	vii
ACKNOWLEDGEMENTS . . . . .	ix
ABSTRACT . . . . .	x
INTRODUCTION . . . . .	1
Microtrabecular Lattice . . . . .	1
Existence of the Microtrabecular Lattice . . . . .	1
Composition of the Microtrabecular Lattice . . . . .	5
Protein Phase of the Cytoplasm . . . . .	6
Glycolytic Enzymes and the Microtrabecular Lattice . . . . .	6
Interactions of Glycolytic Enzymes with Actin . . . . .	7
Interactions of Glycolytic Enzymes with Glycolytic Enzymes . . . . .	17
'Piggy-Backing' . . . . .	21
The Effects of Enzyme Complexes and Enzyme- F-actin Complexes on Metabolism . . . . .	21
Water Phase of the Cytoplasm . . . . .	24
Cellular Water Content . . . . .	24
Simulation of <u>In Vivo</u> Water by PEG . . . . .	26
Statement of the Problem . . . . .	28
MATERIALS AND METHODS . . . . .	30
Materials . . . . .	30
Reagents . . . . .	30
Equipment . . . . .	31
Methods . . . . .	33
Protein Preparations . . . . .	33
Protein Determinations . . . . .	33
Desalting of Enzymes and Myogen . . . . .	33
Spectrophotometric Enzyme Assays . . . . .	34
The Pelleting of Glycolytic Enzymes in the Presence or Absence of F-actin and/or PEG and/or KCl . . . . .	34
The Pelleting of Purified Glycolytic Enzymes in the Presence of Other Purified Glycolytic Enzymes and PEG . . . . .	36
Statistical Comparisons . . . . .	37
RESULTS . . . . .	38
The Pelleting of Fluorescein, a Measure of Pellet Volume . . . . .	39
The Pelleting of Glycolytic Enzymes in the Presence or Absence of F-actin and/or PEG and/or KCl . . . . .	40

TPI and PGM . . . . .	40
PGK and Enolase . . . . .	46
GPI . . . . .	52
Aldolase and GAPDH . . . . .	56
PK and LDH . . . . .	63
The Pelleting of Purified Glycolytic Enzymes in the Presence of Other Purified Glycolytic Enzymes and PEG . . . . .	74
Units of Enzyme Activity Per Sample . . . . .	79
DISCUSSION . . . . .	81
The Pelleting of Glycolytic Enzymes in the Presence or Absence of F-actin and/or PEG and/or KCl . . . . .	81
TPI and PGM . . . . .	84
PGK and Enolase . . . . .	85
GPI . . . . .	86
Aldolase and GAPDH . . . . .	87
PK and LDH . . . . .	89
The Pelleting of Purified Glycolytic Enzymes in the Presence of Other Purified Glycolytic Enzymes and PEG . . . . .	90
Units of Enzyme Activity Per Sample . . . . .	91
Relationship of the Observed Interactions to the Microtrabecular Lattice . . . . .	92
Summary of the Discussion and Future Areas of Research . . . . .	96
APPENDICES . . . . .	101
APPENDIX A. KEY TO ABBREVIATIONS USED IN TEXT . . . . .	102
REFERENCES . . . . .	104

## LIST OF ILLUSTRATIONS

Figure	Page
1. The microtrabecular lattice according to Porter . . . . .	3
2. The microtrabecular lattice and aqueous cytoplasm as depicted by Clegg . . . . .	8
3. The reactions of the glycolytic pathway . . . . .	22
4. Isometric graph of the percent of total activities of TPI found in the pellet fraction . . . . .	42
5. Isometric graph of the percent of total activities of PGM found in the pellet fraction . . . . .	42
6. Isometric graph of the percent of total activities of PGK found in the pellet fraction . . . . .	48
7. Isometric graph of the percent of total activities of enolase found in the pellet fraction . . . . .	48
8. Isometric graph of the percent of total activities of GPI found in the pellet fraction . . . . .	53
9. Isometric graph of the percent of total activities of aldolase found in the pellet fraction . . . . .	59
10. Isometric graph of the percent of total activities of GAPDH found in the pellet fraction . . . . .	59
11. Isometric graph of the percent of total activities of PK found in the pellet fraction . . . . .	70
12. Isometric graph of the percent of total activities of LDH found in the pellet fraction . . . . .	70
13. Isometric graph of the percent of total activities of combinations of purified glycolytic enzymes found in the pellet fraction . . . . .	76
14. Model of the microtrabecular lattice anchored to an actin filament . . . . .	93

## LIST OF TABLES

Table	Page
1. Percent of the total absorbance of fluorescein at 473 nm found in the pellet fraction . . . . .	39
2. Results of the statistical analysis of the pelleting of TPI . . . . .	44
3. Results of the statistical analysis of the pelleting of PGM . . . . .	45
4. Results of the statistical analysis of the pelleting of PGK . . . . .	50
5. Results of the statistical analysis of the pelleting of enolase . . . . .	51
6. Results of the statistical analysis of the pelleting of GPI . . . . .	55
7. Results of the statistical analysis of the pelleting of aldolase . . . . .	61
8. Results of the statistical analysis of the pelleting of GAPDH . . . . .	62
9. Percents of the total activities of PK found in the pellet fraction at 14 percent PEG . . . . .	66
10. Results of the statistical analysis of the pelleting of PK at 14 percent PEG . . . . .	67
11. Percents of the total activities of LDH found in the pellet fraction at 14 percent PEG . . . . .	68
12. Results of the statistical analysis of the pelleting of LDH at 14 percent PEG . . . . .	69
13. Results of the statistical analysis of the pelleting of PK at 11 percent PEG . . . . .	72
14. Results of the statistical analysis of the pelleting of LDH at 11 percent PEG . . . . .	73
15. Percents of the total activities of purified LDH found in the pellet fraction when prepared in combination with other purified glycolytic enzymes and 14 percent PEG . . . . .	75



16.	Results of the statistical analysis of the pelleting of purified glycolytic enzymes in the presence of other purified glycolytic enzymes and 14 percent PEG . . . . .	78
17.	Units of enzyme activity . . . . .	80

## ACKNOWLEDGEMENTS

I am very grateful to Dr. Harvey Knull who not only provided expert technical advice but also maintained a positive attitude and offered many encouraging words throughout this study and other experiments. I thank the members of my graduate committee, Dr. Martin Jones, Dr. David Lambeth, Dr. Robert Nordlie, Dr. Jean Oberpriller, and Dr. James Stewart, for their willingness to be involved.

I am indebted to Dawn Korynta for her skillful technical assistance especially the assaying of many, many enzymes. I would also like to thank Trudy Jacoby, Susan Laursen, and RoxAnn Karkhoff-Schweizer, who not only introduced me to useful laboratory techniques but also offered friendly advice and discussion.

Dale Simmons not only gave expert assistance and advice regarding computers but was also very supportive, understanding, and occasionally delivered tasty meals to the lab. Thanks.

This work was financially supported by grant number 17711 from the National Institutes of Health and I appreciate their assistance. I also thank the Graduate School and the Department of Biochemistry and Molecular Biology for making life as a graduate student economically feasible.

## ABSTRACT

Many studies of the protein interactions that compose the microtrabecular lattice have been done in dilute solutions. However, solutions containing inert polymers such as polyethylene glycol (PEG) more effectively mimic the crowded interior of the cell. Therefore, the interactions of D-glyceraldehyde-3-phosphate ketol-isomerase (TPI, EC 5.3.1.1), D-phosphoglycerate 2,3-phosphomutase (PGM, EC 5.4.2.1), ATP:3-phospho-D-glycerate 1-phosphotransferase (PGK, EC 2.7.2.3), 2-phospho-D-glycerate hydro-lyase (enolase, EC 4.2.1.11), D-fructose-1,6-bisphosphate D-glyceraldehyde-3-phosphate lyase (aldolase, 4.1.2.13), D-glyceraldehyde-3-phosphate:NAD<sup>+</sup> oxidoreductase (GAPDH, EC 5.3.1.1), D-glucose-6-phosphate ketol-isomerase (GPI, EC 5.3.1.9), (S)-lactate:NAD<sup>+</sup> oxidoreductase (LDH, EC 1.1.1.27), and ATP:Pyruvate O<sup>2</sup>-phosphotransferase (PK, EC 2.7.1.40) with each other, with ATP:D-fructose-6-phosphate 1-phosphotransferase (PFK, EC 2.7.1.11) and with F-actin have been studied in the presence of PEG. Rabbit muscle glycolytic enzymes, either purified or as in myogen, were centrifuged in the presence or absence of F-actin and/or PEG and/or KCl for 35 minutes at 145,000 x g. The supernate and pellet were then assayed.

In the absence of PEG and F-actin, the enzymes did not

pellet. PEG and/or F-actin increased and KCl decreased the pelleting of all enzymes studied. A significant increase in pelleting with the addition of PEG and/or F-actin along with a decrease with the addition of KCl indicates the presence of an ionic interaction which is enhanced by PEG. For all of the enzymes tested, an ionic interaction with F-actin that was enhanced by the presence of PEG was evident. GPI, aldolase, GAPDH, PK, and LDH also were tested for the specificity of this interaction by using TPI as a control. All five enzymes demonstrated a specific interaction with F-actin, which for GPI, GAPDH, and PK was enhanced by PEG. More myogen than purified enolase, GPI, aldolase, GAPDH, PK, and LDH pelleted under several conditions. Greater pelleting in samples prepared with myogen than in those prepared with purified enzyme suggests an interaction of the enzyme with the proteins of myogen. Therefore, purified enolase, GAPDH, aldolase, GPI, and LDH were also tested for pelleting with other purified enzymes in the presence of PEG. Aldolase pelleted the most with PK and LDH; GPI, enolase, and GAPDH pelleted the most with PFK; and LDH showed no differences in pelleting with the various enzymes.

## INTRODUCTION

The interior of a cell is classically considered in textbooks as an unorganized solution of proteins with an array of vesicles and organelles. Recently, however, the interior of a cell has been described as a highly organized system with the intracellular organelles, plasma membrane, and cytoskeleton all connected via a network of cytoplasmic proteins termed the microtrabecular lattice. Such a structured cytoplasm implies that proteins, such as the glycolytic enzymes, which are classically considered to be in solution, are actually components of a protein network. Evidence for the existence of the microtrabecular lattice, and, specifically, for glycolytic enzymes as components of the microtrabecular lattice will be presented. The effects that such a structure has on metabolism and on cellular water also will be presented.

### Microtrabecular Lattice

#### Existence of the Microtrabecular Lattice

What is now known as the microtrabecular lattice was first observed by differential interference and electron microscopy and was described as "a continuous, three-dimen-

sional network, composed of threadlike elements" in the axoplasm of the giant nerve fiber of the squid (1,2). Additionally, these threadlike structures were observed to be wound around microtubules (2), which are components of the cytoskeletal system. Another early report, in 1971, described the ultrastructure of growth cones and axons of cultured nerve cells. The ultrastructure in the periphery of growth cones was described as a filamentous network which extended to the axons where it interconnected neurofilaments, vesicles, microtubules, and the plasma membrane (3).

This filamentous structure was first called the microtrabecular lattice by Wolosewicz and Porter in 1976 (4). These researchers refined some high-voltage electron microscopy techniques for studying whole cultured cells derived from lung tissues and described microtubules, microfilaments, ribosomes and vesicles of the endoplasmic reticulum as being contained within the material of the microtrabecular lattice as depicted in Figure 1 (4). That the microtrabecular lattice was not merely an artifact was established by the work of Wolosewicz and Porter who, by using various procedures for fixation, drying, and embedding, and by studying model systems, demonstrated that the microtrabecular lattice took on different forms when cells were exposed to different temperatures (5,6).

Further observations, supporting the existence of the

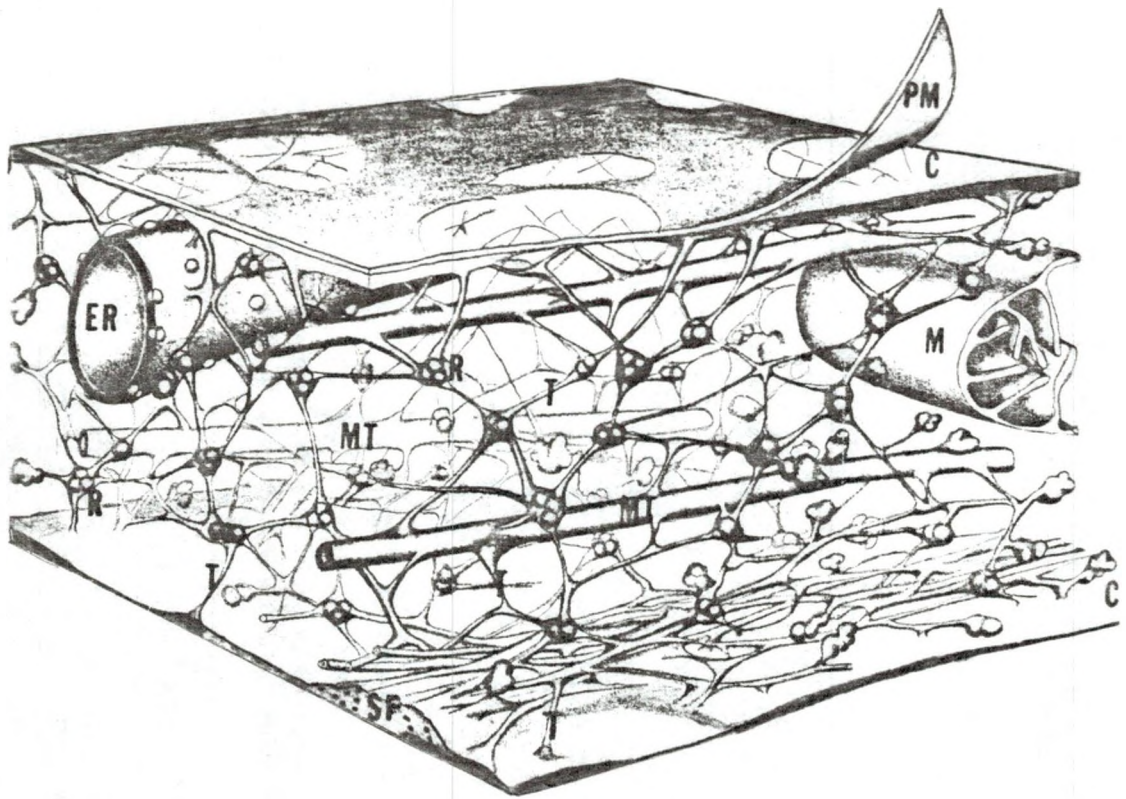

microtrabecular lattice, were made by earlier investigators using procedures such as centrifugation, exposure to various temperatures, introduction and subsequent movement of particles, and microsurgery to study cell structure (7). The general conclusions drawn from these studies were that the cytoplasm could be a liquid or a gel depending on the treatment, that it was able to transform between the two states, and that it had elasticity (7).

#### Composition of the Microtrabecular Lattice

The composition and stability of the microtrabecular lattice to detergent extraction also was studied by Porter's group. Treatment of cells with the detergent Brij 58 removed the plasmalemma and membrane-bound organelles but did not remove other cytoplasmic proteins and left the microtrabecular lattice essentially intact (8). Treatment with the detergent Triton X-100, however, resulted in the release of cytoplasmic proteins and the loss of structural components as judged by electron microscopy (8). A third observation was that actin filaments, which are cytoskeletal components and are not solubilized by Triton X-100, were only susceptible to decoration by meromyosin subfragment 1 after the cells were treated with Triton X-100, suggesting that Triton X-100 removed cytoplasmic proteins that were bound to actin filaments (8).

The existence of the microtrabecular lattice connotes



that the cytoplasm is made up of two phases: 1. a polymeric protein phase composing the microtrabecular lattice and cytoskeleton, and 2. a water phase in which small metabolites are dissolved (8). This structural format of the cytoplasm provokes questions about which proteins are involved, what their organization might be within the microtrabecular lattice, and what effects this structure and its organization have on cellular metabolism.

### Protein Phase of the Cytoplasm

#### Glycolytic Enzymes and the Microtrabecular Lattice

The microtrabecular lattice, as discussed above, seems to be composed of cytoplasmic proteins which, upon subcellular fractionation, are enriched in the cytosol. This suggests that the glycolytic enzymes, which fractionate with the cytosol, may be components of the microtrabecular lattice. Extractions similar to those performed by Porter's group (above) also have been performed on brain slices and cell cultures (9). The results from these experiments revealed that glycolytic enzymes were not extracted nearly as well with Brij 58 as they were when tissues were exposed to Triton X-100 (9), further substantiating the implication that glycolytic enzymes were indeed components of the microtrabecular lattice as observed by electron microscopy. Since the microtrabecular lattice is associated with the cytoskeleton and permeates throughout the cytoplasm, at

least two types of interactions of glycolytic enzymes are implicated: 1. interactions with actin and other cytoskeletal proteins and 2. interactions with other cytoplasmic proteins including the glycolytic enzymes themselves. Both types are depicted in Clegg's schematic drawing of the microtrabecular lattice as shown in Figure 2.

#### Interactions of Glycolytic Enzymes with Actin

Early reports of the association of glycolytic enzymes with the cellular ultrastructure were based on comparisons of enzyme activities in tissue press juices. In these studies, higher LDH<sup>1</sup> and aldolase activities in extracts of minced skeletal muscle as compared to whole skeletal muscle, and their full extraction in phosphate buffer, were interpreted as demonstrating an association of LDH and aldolase with the skeletal muscle ultrastructure (10). Follow-up studies utilizing histochemical and immunofluorescent techniques indicated colocalization of GAPDH, LDH, GPI, aldolase, and TPI with the isotropic bands of rabbit muscle (11-14).

Consequently, the associations of glycolytic enzymes with actin have been investigated by using a variety of methods including activation and inhibition of enzyme

---

<sup>1</sup>A key to the abbreviations used in the text is presented in Appendix A.

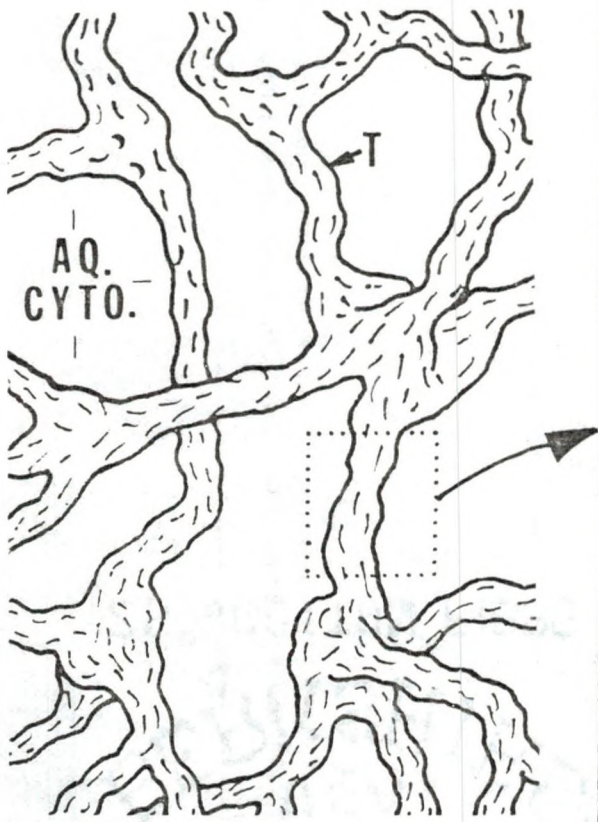

MTL

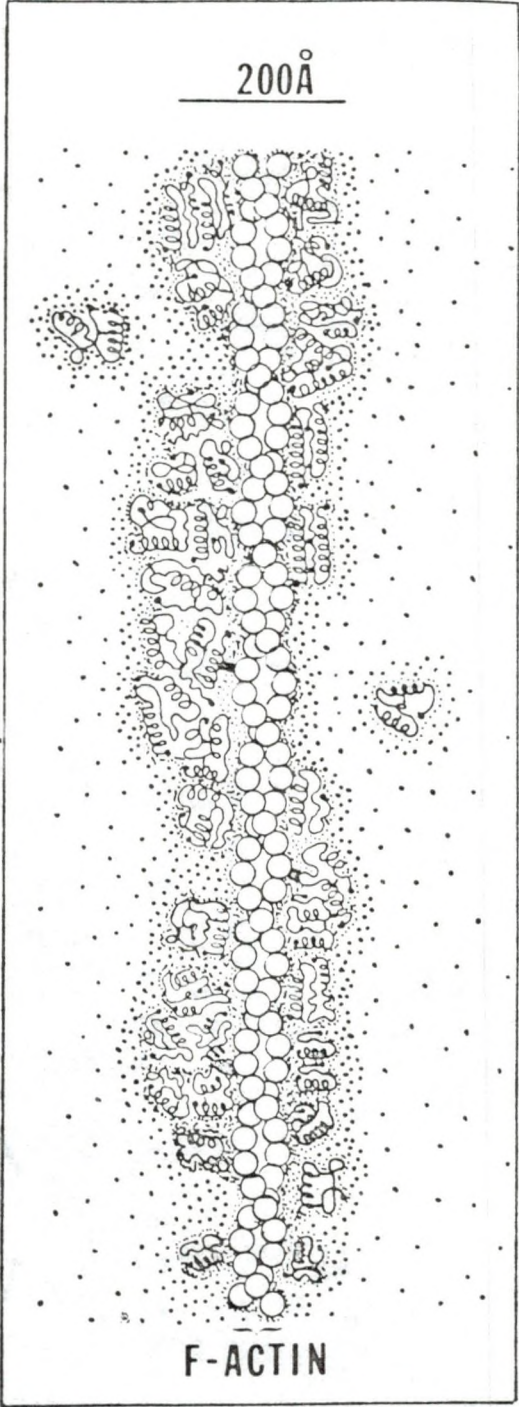

F-ACTIN

activities by actin, coelectrophoresis in agarose gels, counter-current distribution, cosedimentation and partition equilibrium, ease of extraction from muscle tissue, affinity chromatography, and electron microscopy.

F-actin has been shown to stimulate the activities of aldolase and GAPDH, and to inhibit the activity of LDH (16). Agarose gel electrophoresis has shown that GAPDH and aldolase comigrate with F-actin (17). Both techniques indicate interactions between the enzymes studied and F-actin.

Although several changes were only slight, enolase, aldolase, TPI, GAPDH, PGK, PGM, PK, and LDH all changed their counter-current distribution patterns on the addition of actin filaments (18). The latter studies, although suggesting interactions between these glycolytic enzymes and F-actin, were not quantitative. The extent of change of distribution varied among the enzymes with the smallest amount of interaction shown by GAPDH, an enzyme that demonstrated relatively strong interactions in other studies. Furthermore, a different concentration of enzyme was used for each enzyme studied making the comparison of extents of altered distribution difficult.

Affinity chromatography was performed by application of muscle myogen, a high speed supernatant fraction containing the glycolytic enzymes, to an affinity column composed of F-actin-tropomyosin complexes cross-linked to

Sepharose (19). In these experiments, GAPDH, LDH, and aldolase had the greatest affinities; intermediate affinities were shown for PK, PFK, PGK, and PGM; slight affinities of TPI and GPI were detected; and no enolase was retained by the column (19). Additionally, purified muscle aldolase, GAPDH, PGK, LDH, and PK all demonstrated affinities for the column while PGM only showed an affinity for the column after preloading with LDH. Additional experiments were carried out by this same group of researchers, with brain aldolase, GAPDH, and LDH showing an affinity for the F-actin-tropomyosin affinity column (20).

Arnold and Pette (21) studied the cosedimentation of aldolase with F-actin, myosin, actomyosin, and stroma protein from rabbit muscle. The greatest amount of aldolase cosedimenting with F-actin and reversal of binding was achieved with 150 mM KCl (21). Similarly, GAPDH, PGK, PK, and LDH cosedimented with F-actin. In a quantitative comparison of the binding of the glycolytic enzymes, these same researchers found that aldolase, PK, and TPI bound relatively strongly to F-actin; LDH and PGK had less affinity; and PGM and enolase did not bind to F-actin (22). Additionally, analysis of the associations of aldolase and PK revealed two binding sites on F-actin for each and also a complex formation between aldolase and G-actin (22).

Cosedimentation experiments also revealed that GAPDH cosedimented with the particulate fraction of chicken

skeletal muscle (23). This cosedimentation was reversed with increasing ionic strength, increasing pH, or addition of either glyceraldehyde 3-phosphate or 2,3-bisphosphoglycerate (23).

The interactions of sheep muscle glycolytic enzymes, in a myogen preparation, with F-actin or F-actin-troponin-tropomyosin also have been studied by cosedimentation (24). Aldolase, LDH, PK, GAPDH, and GPI demonstrated greater pelleting than did TPI, PGK, PGM, or enolase (24). Higher concentrations of myogen resulted in greater pelleting of the enzymes (24). The greater pelleting could have been due to the crowding effect of a high protein concentration, interactions among the proteins in myogen, or both.

Cosedimentation was also used to determine the extent of glycolytic enzyme binding in brain tissue. The results demonstrate slight cosedimentation of aldolase, GAPDH, and PK with particulate matter at 0°C (25). Cosedimentation increased when the experiment was performed at 37°C (25). The increase in cosedimentation could have been due to the presence of tubulin, which polymerizes and, therefore, pellets more extensively at 37°C. However, actin-depleted samples were also prepared and these demonstrated less sedimentation of the enzymes, indicating that actin was at least in part responsible for the temperature-sensitive sedimentation of these enzymes (26).

Centrifugation also has been used to study the propor-

tions of soluble and bound GAPDH, LDH, and aldolase in skeletal muscle, brain, liver, and kidney at different developmental stages of mice (26-28). Amounts of soluble and bound enzyme varied with the enzyme, tissue, and developmental stage of the animal (26-28). Changes in the binding properties of enzymes during development may reflect an altered cellular ultrastructure due to changes in metabolic emphasis taking place during development (26-28).

Of all the glycolytic enzymes, the association of aldolase with actin has been the most vigorously studied. As mentioned above, the interaction between aldolase and actin has been demonstrated by histochemical colocalization, cosedimentation, and affinity chromatography procedures. Additional histochemical studies have revealed that aldolase could be extracted from rabbit muscle myofibrils by phosphate, reabsorbed to the myofibrils, and localized again in the I-bands (29). Other studies have been carried out on the relative ease of extraction of aldolase from muscle tissue. The extent of extraction of aldolase from muscle depends on the ionic strength of the solution being used (21). Extraction with low ionic strength solutions solubilized 60 to 70 percent of the total activity and complete extraction was obtained with solutions of ionic strength greater than 0.2 (21). These results indicate the association of aldolase with muscle proteins but not

specifically with actin.

In a cosedimentation study, the relative affinities of aldolase isozymes for brain particulate fractions was investigated. These experiments demonstrate that enzyme tetramers containing the A isozyme have a higher affinity for brain particulate fractions than tetramers containing the C isozyme with tetramers completely composed of A having the highest and tetramers completely composed of C having the lowest affinity (30).

The association of aldolase with F-actin has been studied further with the use of electron microscopy (31). In these studies, aggregates formed in mixtures containing aldolase and either F-actin, F-actin-tropomyosin, F-actin-tropomyosin-troponin-I, F-actin-tropomyosin-troponin-T, or F-actin-tropomyosin-troponin-IC (31). Furthermore, a two dimensional lattice structure formed on mixing aldolase with F-actin-tropomyosin-troponin-IT (31).

Additionally, the interaction of aldolase with myofibrils (F-actin containing) has been studied with the use of partition equilibrium (32). These studies demonstrated three characteristics of the association between aldolase and myofibrils: 1. Both rabbit muscle and bovine muscle aldolase bound to myofibrils prepared from bovine cardiac muscle, indicating that there was no species specificity of the interaction; 2. Skeletal muscle myofibrils had a higher affinity for aldolase than did cardiac muscle myofibrils;



3. Serum albumin used to exclude volume (a concept that will be discussed later) increased the apparent binding constant (32). Further studies by Kuter et al. (33) demonstrated that this association was competitively inhibited by phosphate, indicating that the active site of aldolase may be involved in this interaction.

Finally, attempts have been made to identify the specific site on aldolase that is involved in the association with actin. Kinetic studies suggest either that aldolase activity is competitively inhibited by adsorption onto myofibrils (a preparation containing actin) or that fructose 1,6-bisphosphate is a competitive inhibitor of enzyme binding (34). These kinetic effects could also be attributed to conformational changes occurring on binding and do not necessarily localize the site on aldolase responsible for binding to myofibrils at the same site responsible for enzyme activity. An attempt to identify the specific spacial location of the binding site has been made, by studying the effects of partial proteolysis of aldolase on its binding to actin and on the binding of substrates. The authors concluded that the substrate and actin binding sites were distinct (35).

Topographical localization of the site on GAPDH responsible for binding also has been performed. In these experiments, the effect of limited proteolysis on the association of GAPDH with actin and on enzyme activity was

studied (36). The results indicate that the site responsible for association with actin is different from the parts of the protein responsible for kinetic activity (36).

The binding of PFK to actin also has been given particular attention. Several approaches have been used to delineate the interaction between PFK and F-actin in addition to affinity chromatography which was mentioned earlier. The site responsible for binding to actin has been demonstrated, by the use of limited proteolysis, to be distinct from sites responsible for enzyme activity (36). The subcellular distribution of PFK in bovine cardiac muscle has been studied by extraction and by studying interactions with cardiac myofibrils (37). PFK bound to particulate fractions at low ionic strength and was solubilized with either the addition of salt or substrates (37). Comparison of cardiac muscle studies with cardiac myofibril studies led to the conclusion that myofibrils were responsible for the association of PFK with the particulate fractions of cardiac muscle (37). Furthermore, the binding of PFK to the myofibrils resulted in activation of the enzyme (37). This observation is consistent with the findings of other researchers of the activation of rabbit muscle PFK by actin (38,39). The phosphorylated form of rabbit muscle PFK is much more sensitive to actin activation than is the dephosphorylated form (38,39). These two findings, along with the observation that stimulation of

muscle contraction results in phosphorylation of the enzyme, indicate a possible physiologic sequence of events: a) stimulation of contraction b) phosphorylation of the enzyme c) association with actin filaments and d) subsequent activation of PFK a time when the myofibrils would have a need for energy.

#### Interactions of Glycolytic Enzymes with Glycolytic Enzymes

Although the existence of interactions among glycolytic enzymes has been disputed by de Duve (40), several interactions have been demonstrated by other investigators. Evidence in support of a glycolytic enzyme complex has accumulated, not only through demonstration of specific interactions such as PFK with several other enzymes; aldolase with GAPDH and with TPI; and GAPDH with PGK, but also through general enzyme aggregation. Many of these interactions have been summarized and ordered into a supramolecular complex by Kurganov, et al. (41).

PFK immobilized on agarose gel has been demonstrated to form complexes with several enzymes including GPI, aldolase, GAPDH, enolase, PK, and LDH (42). In this study, a rabbit muscle extract was applied to a column of PFK-agarose gel and bound enzymes were eluted with an increasing KCl gradient (42). However, in other studies, GPI and aldolase had no effect on the kinetic behavior of PFK which was affected by fructose-1,6-bisphosphatase (43).

These results, in contrast to the studies using the PFK-agarose gel, led to the conclusion that there was no interaction between either GPI and PFK or aldolase and PFK (43).

An interaction between aldolase and GAPDH has been demonstrated by three different methods in four different investigations. The first method is the study of the kinetics of the enzymes. The stimulation of tuna muscle aldolase by tuna muscle GAPDH suggested that a complex was formed between the enzymes (44). The reduced  $K_m$  value observed for glyceraldehyde-3-phosphate in a coupled aldolase-GAPDH system not only supported the formation of an enzyme complex but also suggested that the complex formation resulted in direct transfer of the metabolite from aldolase to GAPDH (45). The second method used to study the aldolase-GAPDH interaction was polarized fluorescence which indicated the formation of a complex containing two aldolase tetramers bound per tetramer of GAPDH with an apparent dissociation constant of  $3 \times 10^{-7}$  M (46). A third method involved the production of an inactivating aldehyde intermediate by aldolase which lost reactivity on diffusion into solvent. However, the intermediate inactivated the aldolase molecule that produced it and also inactivated GAPDH when the reaction was carried out in the presence of both enzymes (47). This inactivation of GAPDH could only result from a direct transfer of the product from aldolase to GAPDH which suggests complex formation (47).

Evidence for an interaction between aldolase and TPI has also been reported. Aldolase and TPI demonstrated mutual protection against denaturation by perchloric acid (48). Also, the fluorescence anisotropy of fluorescently-labeled TPI increased in the presence of aldolase with an apparent dissociation constant of  $1.7 \mu\text{M}$ , both indicating complex formation (48). The inhibition of aldolase activity by TPI also suggested complex formation (49).

The demonstration of aldolase complex formation with GAPDH and TPI prompted questions about the relative extents of formation of these complexes and their possible effects on glycolytic flux in vivo. One investigation used fluorescence anisotropy and kinetic studies to demonstrate that a TPI-GAPDH complex was not being formed, that the amount of aldolase-GAPDH complex was reduced in the presence of TPI, and that TPI actually decreased the steady-state velocity of the coupled aldolase-GAPDH reaction (50). These results led to the conclusion that GAPDH and TPI may alternately bind to aldolase and that the conformation may affect the rate of glycolytic flux (50).

The possibility of an interaction between GAPDH and PGK has been investigated using several techniques and several different sources of enzyme. A possible interaction between pig muscle GAPDH and PGK has been investigated by kinetic analysis, fluorescence anisotropy, and gel chromatography, leading to the conclusion that there was no

interaction (51). However, kinetic studies of halibut muscle GAPDH and PGK indicate that while a direct enzyme interaction may not occur, a complex may form via 1,3-bisphosphoglycerate, the common intermediate (52). Furthermore, studies of yeast enzymes indicated: that an interaction between GAPDH and PGK exists; that the substrate, 1,3-bisphosphoglycerate is necessary for this interaction but is also released into solution and so is not the link between the two enzymes; and that binding of PGK to GAPDH results in loss of cooperativity among the four GAPDH subunits (53,54).

General enzyme aggregation has been suggested by an investigation of the effects of PEG on the rate of glycolysis. PEG, the effects of which will be discussed in detail in a separate section, increased the rate of lactate production from glucose in a rat liver extract (55). A general enzyme complex also was formed in samples prepared with myogen, a high speed supernatant fraction of muscle tissue (56). These studies demonstrated the formation of a complex which contained LDH, aldolase, PK, and PFK (56). The complex formation was dependent on the absence of metabolites, appropriate pH, low ionic strength, and the presence of myosin, a protein component of the myogen preparation (56).

### 'Piggy-Backing'

'Piggy-backing' is the term used by Clarke et al. (57) to describe the interaction of an enzyme with a second enzyme which is bound to F-actin. An example is the interaction of PGM with an F-actin-tropomyosin affinity column only after it had been pre-loaded with LDH (19). 'Piggy backing' also has been demonstrated for the interaction of rabbit muscle TPI with either aldolase or GAPDH bound to muscle myofibrils (58). No interaction of TPI with muscle myofibrils took place unless either aldolase, GAPDH, or both were also present (58).

### The Effects of Enzyme Complexes and Enzyme-F-actin Complexes on Metabolism

Several authors have reviewed the advantages that an organized multienzyme system, such as the organization of the glycolytic enzymes (glycolysis is shown in Figure 3) along an actin filament, would have on cellular metabolism (59-63). The following list by Srere (62) encompasses the discussions of the other reviewers as well.

1. If the substrates can be transferred directly from one active site to another (channeling) so that the substrate's concentration in the microenvironment of the second site is kept relatively high compared to the average bulk concentration of that substrate, then one spares the limited solvation capacity of cellular water.
2. In these situations one achieves high concentrations of substrates [in the vicinity of the appropriate enzymes] with fewer substrate molecules.
3. When the input into a sequence of metabolic reactions is changed [such as a change in the sub-

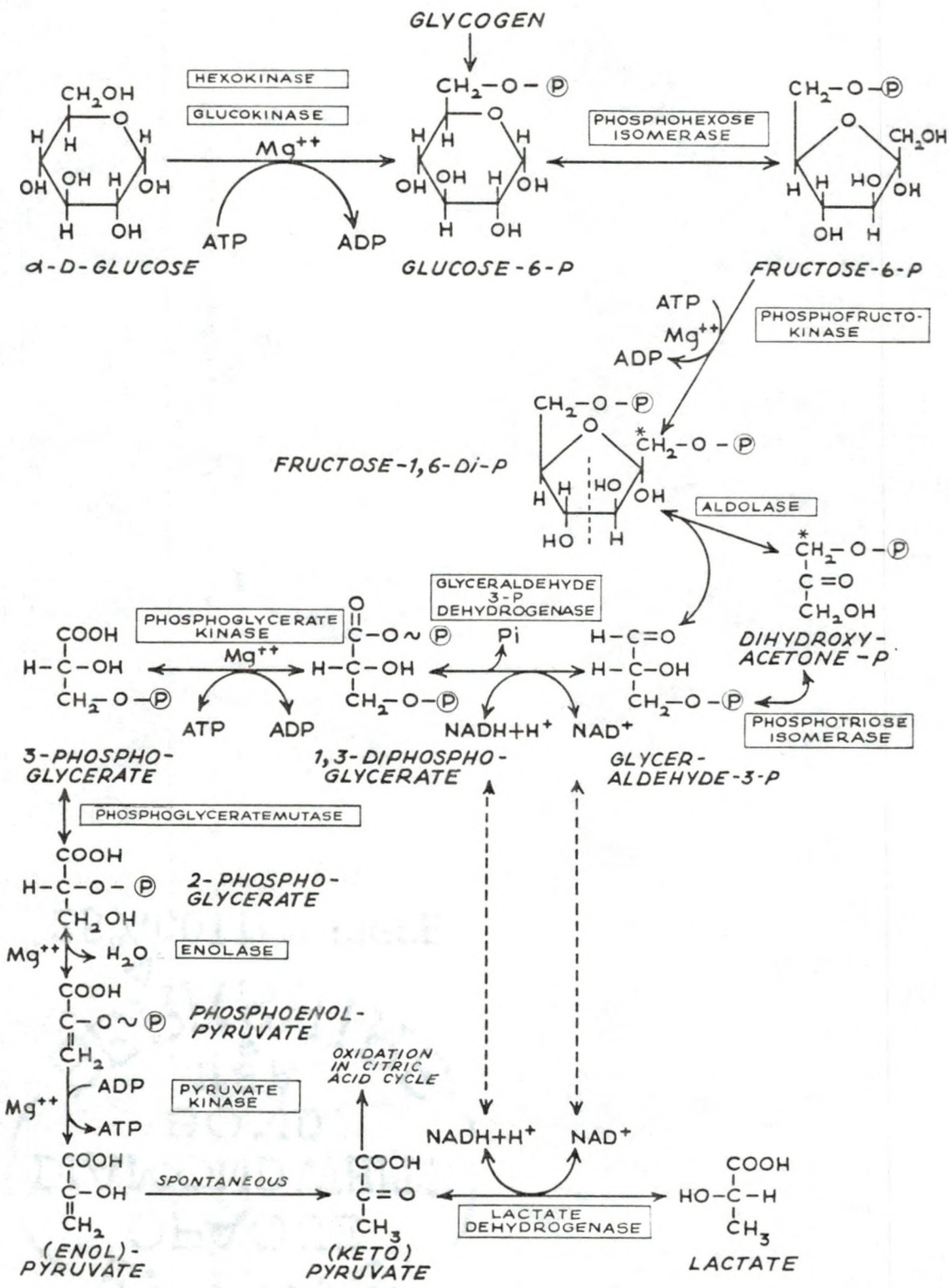



strate level for the first enzyme of the sequence], then the transient time for the attainment of a new steady state is reached faster for a multienzyme complex than for comparable enzyme activities free in solution. 4. If substrates are unstable in aqueous environments or if they can be acted on by other enzymes, then direct transfer to a successive active site is a mechanism for their preservation. 5. Interactions between the sequential proteins have been shown to have allosteric (thus regulatory) effects on the activities involved. 6. Such complexes, if they are attached to or are part of cellular structural elements or macromolecules, would have the advantage that the diffusion of their enzymatic components could possibly take place in two dimensions or one dimension rather than three dimensions (62).

### Water Phase of the Cytoplasm

#### Cellular Water Content

By electron microscopic study of the microtrabecular lattice, Wolosewick and Porter (5) estimate that approximately 80 percent of the cytoplasmic volume is comprised of intratrabecular space which varies with the cell type and method of fixation. Since the cytoplasm is made of two phases, one proteinaceous and the other mostly water, these intratrabecular spaces would be filled with water in a living cell. The actual water content of cells is difficult to determine because there is variability between cell types and because viable cells are not necessarily fully hydrated.

In studies by Clegg (65) using *Artemia* cysts, metabolism proceeded at a rate dependent on water content in cells containing between 0.65 and 0.8 g of water per g dry weight of cells and was independent of water content

between 0.8 and 1.4 g water per g dry weight of cells (65). Other cells have also been shown to be viable after loss of 50 to 80 percent of the total cell water (65). An interesting point made by Lechene (66) regarding cellular water and the cytoplasm is that a gel state is favorable because it allows the cell to avoid osmotic swelling and dehydration more effectively than a soluble state would. By using Gershon's (67) estimate that the surface area of the microtrabecular lattice and cytoskeleton is 50,000-100,000  $\mu\text{m}^2$ , and the values of  $3 \times 10^{-4}$   $\mu\text{m}$  for the thickness of one water molecule and 50 percent for the water content of the cell, Clegg (65) estimates that a monolayer of water covering only the microtrabecular lattice and cytoskeleton would require 2-4 percent of the total cellular water (65). Proteinaceous structures may influence the structure of water up to 17 layers away (65). This estimate implies that the microtrabecular lattice and cytoskeleton may impose structural restrictions on 34 to 68 percent of the total cellular water. This estimate does not include the surface areas of all of the other cytoplasmic structures such as membranes, granules, and ribosomes (65). The amount of cellular water that is free to diffuse throughout the cell without being affected by a structural component must be exceedingly small. This is in sharp contrast with the conditions of many in vitro studies which are done in dilute solutions composed mainly of bulk water.

Concomitantly, the amount of water present in the cell influences protein structures. As mentioned above, *Artemia* cysts begin metabolizing at 65 percent water (65) which is also the approximate water content of red blood cells (68). Protein crystals are approximately 40 percent water or solvent by weight (68). Therefore, the proteins in a cell more closely approximate crystalline structures than the structures formed in dilute solutions which are 99.9 percent water (68). This lack of sufficient water to keep the cytoplasmic contents soluble also favors protein interactions. Interactions of proteins involve associations of protein surfaces which would increase entropy by release of water that formerly was involved in hydration of the surfaces now in contact (69).

#### Simulation of In Vivo Water by PEG

In light of the fact that cellular water does not behave the same as the bulk water composing most solutions, inert molecules, such as PEG, have been added to solutions to more accurately mimic the interior of the cell. The presence of an inert molecule in a protein solution will enhance protein associations due to "the exclusion of protein from that fraction of solution volume occupied by polymer" (70). This phenomenon is known as volume exclusion, volume occupancy, steric exclusion or crowding (70-72). Whether or not PEG is an inert molecule has not

been established. By assuming that proteins and PEG are hard-spherical particles (which is very unlikely), Minton's calculations suggest that there is an attractive interaction between PEG and some proteins, but not between molecules of PEG (70). However, Nichol et al. (72) prefer to treat PEG as an inert polymer and conclude that, in vitro, PEG mimics the concentrated macromolecular condition in vivo. Furthermore, Arakawa and Timasheff (73) also studied the interaction of PEG with B-lactoglobulin and concluded that the major effect of PEG was steric exclusion and that B-lactoglobulin was preferentially hydrated (PEG was preferentially excluded from the domain of the protein compared to water).

PEG has been used in several studies of interactions between the various enzymes of the Krebs tricarboxylic acid cycle and between these enzymes and the inner mitochondrial membrane. PEG at a concentration of 14 percent did not change the nature of the interaction between malate dehydrogenase and the inner mitochondrial membrane but did allow the interaction to be observed at higher ionic strength (74). The interaction between citrate synthase and mitochondrial malate dehydrogenase was also studied in the presence of 14 percent PEG which, when combined with centrifugation, resulted in sedimentation of the complex (75). Citrate synthase also coprecipitates with thiolase in the presence of 12 percent PEG (76) and with the pyruvate

dehydrogenase complex in the presence of 5 percent PEG (77). Succinate thiokinase and the alpha-ketoglutarate dehydrogenase complex also form a precipitable complex in the presence of 5 percent PEG (78).

The effect of PEG on the enzyme activity of a few glycolytic enzymes has also been studied. Several kinetic parameters of pyruvate kinase from rat liver were affected by the presence of 10 percent PEG while neither pyruvate kinase from rabbit muscle nor fructose-1,6-bisphosphatase from rat liver were affected (79).

#### Statement of the Problem

As presented above, the cytoplasm is a structured and organized system containing the microtrabecular lattice as one of its components. The microtrabecular lattice is made up of proteins contained in the cytoplasm, but the elucidation of the multitude of specific interactions necessary to compose this structure has barely begun. After considering the concentration of water and protein in cells, it is evident that studies done in dilute solutions do not reflect the cellular ratios of protein to free water. Intracellular conditions can be more effectively mimicked by the addition of inert polymers, such as PEG, to the protein solutions under study. Therefore it was of interest to study the effects of PEG on the interactions of glycolytic enzymes with F-actin and with other glycolytic

enzymes. This study may lead to a better understanding of the types of interactions that occur within the micro-trabecular lattice. The interactions were studied by testing purified glycolytic enzymes and a mixture of glycolytic enzymes, as found in myogen, for cosedimentation with F-actin in the presence and absence of PEG at various ionic strengths. Cosedimentation of combinations of purified glycolytic enzymes in the presence of PEG also was tested.

## MATERIALS AND METHODS

### Materials

#### Reagents

PEG with an approximate molecular weight of 8000, sodium phosphate, Hepes, DTT, BSA (fatty acid free), ethylenediaminetetraacetic acid (free acid), NADP, Tris base, Coomassie Brilliant Blue G, triethanolamine, nicotinamide adenine dinucleotide (both reduced and oxidized forms), fluorescein (sodium salt), pyruvate (sodium salt), L-lactate, phosphoenolpyruvate (trisodium salt), fructose 6-phosphate (disodium salt), fructose 1,6-bisphosphate (trisodium salt), glyceraldehyde 3-phosphate (free acid), 2-phosphoglyceric acid (sodium salt), 3-phosphoglyceric acid (disodium salt), 2,3-diphosphoglyceric acid (pentacyclohexylammonium salt), adenosine 5'-triphosphate (disodium salt), sodium carbonate, and all commercially purified glycolytic enzymes, including GPI, aldolase, GAPDH, TPI, PGM, PGK, enolase, PK, LDH, PFK, glycerophosphate dehydrogenase-TPI, and glycerophosphate dehydrogenase, were obtained from Sigma Chemical Company, St. Louis, Missouri, and were used without further purification. All glycolytic enzymes used as coupling enzymes in enzyme assays were isolated from rabbit muscle except LDH

which was isolated from bovine heart and PGK which was isolated from yeast. All glycolytic enzymes used for studying interactions were isolated from rabbit muscle.

Sodium hydroxide and nitric acid were purchased from Fisher Scientific Co., Pittsburgh, Pennsylvania. Thymol was obtained from the J. T. Baker Company, Phillipsburg, New Jersey. Ammonium sulfate was purchased from Bio-Rad Laboratories, Richmond, California. Hydrochloric acid was obtained from Harleco, Philadelphia, Pennsylvania. Potassium chloride, potassium phosphate, phosphoric acid (85 percent), magnesium chloride, acetone, calcium chloride, and magnesium sulfate were purchased from Mallinckrodt Chemical Works, St. Louis, Missouri. Ethanol (95 percent) was purchased from USI Chemicals Co., Rolling Meadows, Illinois. All solutions were made to volume with Q water (distilled water which was further purified with a Milli-Q Water Purification System, Millipore Water Systems, Millipore Corporation, Bedford, Massachusetts).

### Equipment

Solutions were adjusted to the desired pH as measured with a Selectromark Analyzer and combination pH/reference electrode from Markson Science Inc., Del Mar, California, with either hydrochloric acid or sodium hydroxide.

Enzyme assays were performed in 0.5 ml quartz cuvettes using a Beckman DU spectrophotometer, updated with a



Gilford power supply, photometer, and automatic cuvette positioner, which was interfaced with a Beckman recorder and equipped with a Haake circulating water bath.

Ultracentrifugations were carried out in either a Beckman model L or L8-80 centrifuge using either a Type 70 Ti, Type 50 Ti, or Type 80 Ti rotor with appropriate size polycarbonate centrifuge tubes all from Beckman. Slow speed centrifugations were accomplished with the use of either a Sorvall RC-5B centrifuge with Sorvall GSA and SS-34 rotors or a Beckman model J-6 centrifuge with a TY JS-5.2 rotor.

Hamilton syringes, polypropylene microcentrifuge tubes, and other miscellaneous supplies were purchased from American Scientific Products, McGaw Park, Illinois. Micro pipettors were obtained either from the Rainin Instrument Company, Woburn, Massachusetts, or from Denville Scientific Inc., Denville, New Jersey. Sartorius balances were used when solid samples were measured. Polyethylene supports for desalting columns were cut from polyethylene purchased from Bel-Art Products, Pequannock, New Jersey. The following equipment was purchased from the companies indicated: a meat grinder from Sears; a Tissumizer from the Tekmar Company, Cincinnati, Ohio; a Vortex-Genie from Scientific Industries, Inc. Bohemia, New York; and plastic disposable syringes from Becton, Dickinson and Company, Rutherford, New Jersey.

## Methods

### Protein Preparations

Acetone-dried muscle powder was prepared by the method of Katz (80) and stored frozen at  $-20^{\circ}\text{C}$ . F-actin was purified from the acetone-dried muscle powder by the three polymerization-depolymerization cycle method of Katz (80). Purified F-actin was stored refrigerated in the presence of thymol and was used within three weeks. Rabbit muscle myogen was prepared as described by Bronstein and Knull (19) and was stored refrigerated as an ammonium sulfate suspension. Commercially purified enzyme preparations were used without further purification.

### Protein Determinations

Protein concentrations were estimated using the dye-binding method of Bradford (81) with BSA as a standard. The concentration of the BSA was estimated by measuring absorbance at 280 nm and using an extinction coefficient of 6.6 for a 1 percent solution (81).

### Desalting of Enzymes and Myogen

Samples were desalted by a modification of the procedure of Neal and Florini (82). Sephadex G-25-300 columns were prepared by filling either 5 or 10 ml plastic disposable syringes with preswollen Sephadex and preequilibrating with 10 volumes of desired buffer. The

column was then placed in a centrifuge tube and centrifuged at 1500 RPM for 5 min. using a Beckman model J-6 refrigerated centrifuge. The ammonium sulfate suspensions were diluted 1 to 10 in the desired buffer and placed on top of the prepared column which was again spun as described above. The desalted protein was collected in the centrifuge tube.

#### Spectrophotometric Enzyme Assays

Aldolase, GAPDH, LDH, GPI, PGK, PGM, TPI, and enolase were assayed according to the procedures described by Bergmeyer et al. (83), with the aldolase assay modified by using Hepes rather than triethanolamine as the buffer. PK was assayed according to Tamir et al. (84). All assays were conducted at 30°C and either the disappearance of NADH or the appearance of NADPH was followed by measuring the change in absorbance at 340 nm. One unit of enzyme activity is defined as that amount catalyzing the conversion of 1  $\mu$ mole of substrate to product per minute.

#### The Pelleting of Glycolytic Enzymes in the Presence or Absence of F-actin and/or PEG and/or KCl

The buffer used in the interaction experiments consisted of 45 mM Hepes and 5 mM sodium phosphate (pH 7.0) and, since it is the only buffer used, will be referred to simply as buffer. All enzyme, PEG, and DTT solutions were made with buffer. Samples and solutions were kept on ice at

all times except 28 percent PEG which was not kept on ice due to its observed crystallization. Enzyme preparations in ammonium sulfate suspensions, including myogen, GPI, GAPDH, enolase, and PGM were dissolved in buffer and desalted. Enzyme preparations purchased as lyophilized powders were dissolved in buffer. Samples contained either 130  $\mu\text{g}$  of myogen or  $7 \times 10^{-11}$  moles of purified enzyme; with or without 300  $\mu\text{g}$  of F-actin; either 0, 0.15, or 0.30 M KCl; and/or 75  $\mu\text{l}$  of 28 percent PEG for a final concentration of 14 percent. Each sample was brought to a final volume of 150  $\mu\text{l}$  with buffer in a 1.9 ml polycarbonate microcentrifuge tube. DTT was added to 0.5 mM in samples containing GAPDH. Pelleting of LDH and PK were also tested in the presence of 11 percent PEG.

Samples were mixed by vortex action in 1.9 ml microcentrifuge tubes which were then placed in 11 ml polycarbonate centrifuge tubes and immediately centrifuged at  $140,000 \times g$  for 35 min at  $4^{\circ}\text{C}$ . Supernates were decanted from pellets. To remove any supernate adhering to the centrifuge tube, pellets were washed with 150  $\mu\text{l}$  of buffer which was discarded. The pellets were then resuspended in 7 percent PEG, 0.2 M KCl, and buffer to a final volume of 150  $\mu\text{l}$ . To avoid misleading results due to the alteration of enzyme activity by PEG, all supernates were diluted to 7 percent PEG. Additionally, supernates from samples prepared with GAPDH were also adjusted to 0.2 M KCl. Supernatant and

pellet fractions were then assayed for enzymatic activity.

Preparations containing purified aldolase, GPI, GAPDH, PK, and LDH were tested for specificity of pelleting by measuring their pelleting in samples prepared with TPI instead of F-actin. These samples contained  $7 \times 10^{-11}$  moles of purified enzyme, as in other preparations, and contained 430  $\mu\text{g}$  of TPI, an amount equivalent to the protein content of samples containing F-actin (300  $\mu\text{g}$ ) and myogen (130  $\mu\text{g}$ ).

The amount of enzyme randomly trapped in the pellet due to the pellet volume was estimated by preparing samples containing fluorescein and the various amounts of F-actin, PEG, and KCl.

#### The Pelleting of Purified Glycolytic Enzymes in the Presence of Other Purified Glycolytic Enzymes and PEG

Enzyme-enzyme interactions were investigated by the same general procedure described above for the interactions of glycolytic enzymes with F-actin. Samples were prepared with  $7 \times 10^{-11}$  moles of each of two purified glycolytic enzymes, a final concentration of 14 percent PEG, 0.5 mM DTT and were brought to a final volume of 150  $\mu\text{l}$  with buffer. F-actin was omitted from all samples. All supernatant and pellet fractions were adjusted to a final concentration of 7 percent PEG and 0.2 M KCl prior to enzyme assay. Purified phosphofructokinase, purchased and stored as a precipitate in 3.2 M ammonium sulfate, was dissolved in stabilization buffer (85) and desalted over columns preequilibrated with the same buffer.

### Statistical Comparisons

Pairwise multiple comparisons of the groups of data for a particular enzyme were performed using the MCPAIR program, which is part of the BIOM statistical programs (86), and the accompanying text, Biometry (87), and statistical tables (88). All samples sizes were  $\geq 3$ . For interactions among glycolytic enzymes, the Tukey-Kramer, GT2, and T' statistics were all considered. However, due to limited tabulated values, only the Tukey-Kramer statistic was considered for evaluation of the interactions of glycolytic enzymes with F-actin. In the following sections, a difference, increase, or decrease refers to a difference that is statistically significant with  $p \leq 0.05$  unless otherwise specified. In accordance with common statistical procedures, the values signified in the tables representing the results of statistical analyses are as follows: not significant is denoted by ns; significantly different is denoted by \*; and highly significantly different is denoted by \*\*.

## RESULTS

The results will be reported in the following four sections. First, the results of the pelleting of fluorescein as a measurement of pellet volume will be presented, and second will be the results of the pelleting of the glycolytic enzymes. In the first two sections, results will be presented under the following four conditions: condition 1 representing the absence of both F-actin and PEG, condition 2 representing the absence of F-actin and presence of PEG, condition 3 representing the presence of F-actin and absence of PEG, and condition 4 representing the presence of both F-actin and PEG. The results of the pelleting of the glycolytic enzymes will be presented in the following groups: TPI and PGM which are represented in Figures 4 and 5; PGK and enolase which are represented in Figures 6 and 7; GPI which is represented in Figure 8, aldolase and GAPDH which are represented in Figures 9 and 10; and PK and LDH which are represented in Figures 11 and 12. Third, the results of glycolytic enzyme pelleting in combination with other specific glycolytic enzymes will be presented. Fourth, the units of enzyme activities in samples prepared with purified enzyme versus samples prepared with myogen will be presented.

The Pelleting of Fluorescein,  
a Measure of Pellet Volume

Pellet volume, measured by the presence of fluorescein in the pellet fraction, ranged from 0 to 7 percent of the total sample volume (table 1). No fluorescein pelleted in the absence of both PEG and F-actin nor in the presence of PEG and absence of F-actin. Slight pelleting of fluorescein occurred in the presence of F-actin and absence of PEG. The most pelleting occurred in the presence of both F-actin and PEG. Pellet volume was considered to be negligible and, therefore, the results for the pelleting of the glycolytic enzymes were not adjusted for nonspecific activity in the pellet due to pellet volume.

---

Table 1: Percent of the total absorbance of fluorescein at 473 nm found in the pellet fraction. Samples were prepared as described in the Materials and Methods section. All values are means  $\pm$  S.E.

---

	<u>Cond. 1<sup>a</sup></u>	<u>Cond. 2<sup>b</sup></u>	<u>Cond. 3<sup>c</sup></u>	<u>Cond. 4<sup>d</sup></u>
<u>M KCl</u>				
0	0 $\pm$ 0	0 $\pm$ 0	2 $\pm$ 0.5	7 $\pm$ 2
0.15	0 $\pm$ 0	0 $\pm$ 0	2 $\pm$ 0.6	3 $\pm$ 0.9
0.30	0 $\pm$ 0	0 $\pm$ 0	3 $\pm$ 0.3	3 $\pm$ 0.7

---

<sup>a</sup> Cond. 1 represents the absence of both PEG and F-actin.

<sup>b</sup> Cond. 2 represents the presence of 14 percent PEG and absence of F-actin.

<sup>c</sup> Cond. 3 represents the absence of PEG and presence of F-actin.

<sup>d</sup> Cond. 4 represents the presence of both PEG and F-actin.



The Pelleting of Glycolytic Enzymes in the Presence or

Generally, as is evident from Figures 4 to 12, the pelleting of the glycolytic enzymes was least in the absence of F-actin and PEG, increased in the presence of either F-actin or PEG, was greatest in the presence of both F-actin and PEG, and decreased with the addition of KCl.

TPI and PGM

The amounts of TPI and PGM found in the pellet fractions are shown in Figures 4 and 5. Pelleting increased with the addition of F-actin and/or PEG. However, the percent of activity found in the pellet fraction never exceeded 20 percent of the total enzyme activity. Results of the statistical analyses of the pelleting are shown in tables 2 and 3.

TPI demonstrates reduced pelleting with increasing ionic strength. Pelleting of TPI increased with F-actin in the presence of PEG and also increased with PEG in the presence of F-actin and absence of KCl. Virtually no differences between the pelleting of purified and myogen TPI were observed.

PGM demonstrates diminished pelleting with the addition of salt for the purified enzyme in the presence of both F-actin and PEG. Increased pelleting with F-actin, in the presence of PEG and absence of salt for both purified and myogen enzymes and for the purified enzyme in the

absence of PEG and presence of 0.30 M salt also is evident. Pelleting of PGM in samples prepared with myogen increased with PEG in the presence of F-actin and absence of salt. Purified PGM demonstrated slightly more pelleting than PGM in samples prepared with myogen in the absence of both F-actin and PEG, and in the presence of F-actin and absence of PEG, but these differences were not significant.

### TRIOSE-PHOSPHATE ISOMERASE

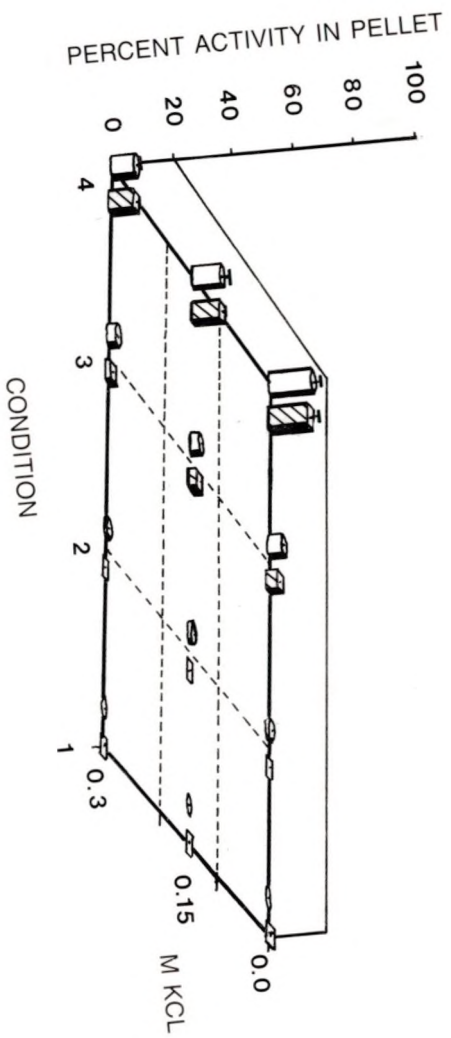

### PHOSPHOGLYCERATE MUTASE

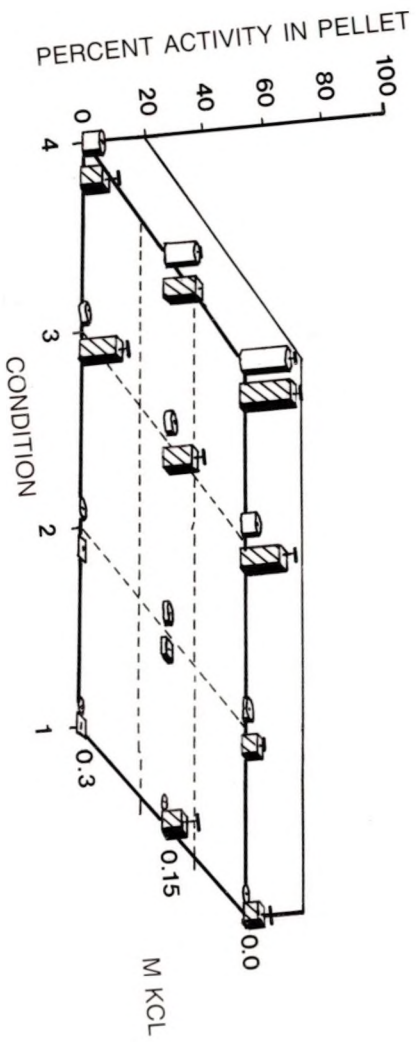

Table 2. Results of the statistical analysis of the pelleting of TPI. The results of TPI pelleting as shown in Figure 4 were statistically analyzed as described in the Materials and Methods section.

<u>Effect of KCl (none vs indicated concentration)</u>								
Enzyme:	<u>pure</u>				<u>myogen</u>			
Condition:	<u>1</u>	<u>2</u>	<u>3</u>	<u>4</u>	<u>1</u>	<u>2</u>	<u>3</u>	<u>4</u>
<u>Salt</u>								
0.15 M	ns	ns	ns	**	ns	ns	ns	ns
0.30 M	ns	ns	ns	*	ns	ns	ns	**

<u>Effect of F-actin (presence vs absence)</u>					
Enzyme:	<u>pure</u>			<u>myogen</u>	
PEG:	<u>0%</u>	<u>14%</u>		<u>0%</u>	<u>14%</u>
Condition:	<u>1,3</u>	<u>2,4</u>		<u>1,3</u>	<u>2,4</u>
<u>Salt</u>					
0 M	ns	**		ns	**
0.15 M	ns	*		ns	**
0.30 M	ns	**		ns	**

Enzyme:	<u>pure</u>		<u>myogen</u>	
Protein:	<u>F-actin</u>	<u>none</u>	<u>F-actin</u>	<u>none</u>
Condition:	<u>3,4</u>	<u>1,2</u>	<u>3,4</u>	<u>2,4</u>
<u>Salt</u>				
0 M	**	ns	**	ns
0.15 M	ns	ns	**	ns
0.30 M	ns	ns	ns	ns

<u>Effect of Myogen (pure vs myogen)</u>					
Actin:	<u>none</u>		<u>300 <math>\mu</math>g</u>		
PEG:	<u>0</u>	<u>14%</u>	<u>0</u>	<u>14%</u>	
Condition:	<u>1</u>	<u>2</u>	<u>3</u>	<u>4</u>	
<u>Salt</u>					
0 M	ns	ns	ns	ns	
0.15 M	ns	ns	ns	ns	
0.30 M	ns	ns	ns	ns	

Table 3. Results of the statistical analysis of the pelleting of PGM. The results of PGM pelleting as shown in Figure 5 were statistically analyzed as described in the Materials and Methods section.

<u>Effect of KCl (none vs indicated concentration)</u>								
Enzyme:	<u>pure</u>				<u>myogen</u>			
Condition:	<u>1</u>	<u>2</u>	<u>3</u>	<u>4</u>	<u>1</u>	<u>2</u>	<u>3</u>	<u>4</u>
<u>Salt</u>								
0.15 M	ns	ns	ns	ns	ns	ns	ns	ns
0.30 M	ns	ns	ns	*	ns	ns	ns	ns

<u>Effect of F-actin (presence vs absence)</u>					
Enzyme:	<u>pure</u>			<u>myogen</u>	
PEG:	<u>0%</u>	<u>14%</u>		<u>0%</u>	<u>14%</u>
Condition:	<u>1,3</u>	<u>2,4</u>		<u>1,3</u>	<u>2,4</u>
<u>Salt</u>					
0 M	ns	**		ns	**
0.15 M	ns	ns		ns	ns
0.30 M	*	ns		ns	ns

<u>Effect of PEG (0 vs 14%)</u>					
Enzyme:	<u>pure</u>		<u>myogen</u>		
Protein:	<u>F-actin</u>	<u>none</u>	<u>F-actin</u>	<u>none</u>	
Condition:	<u>3,4</u>	<u>1,2</u>	<u>2,4</u>	<u>1,2</u>	
<u>Salt</u>					
0 M	ns	ns	*	ns	
0.15 M	ns	ns	ns	ns	
0.30 M	ns	ns	ns	ns	

<u>Effect of Myogen (pure vs myogen)</u>					
Actin:	<u>none</u>		<u>300 <math>\mu</math>g</u>		
PEG:	<u>0</u>	<u>14%</u>	<u>0</u>	<u>14%</u>	
Condition:	<u>1</u>	<u>2</u>	<u>3</u>	<u>4</u>	
<u>Salt</u>					
0 M	ns	ns	ns	ns	
0.15 M	ns	ns	ns	ns	
0.30 M	ns	ns	ns	ns	

PGK and Enolase

The percentages of PGK and Enolase found in the pellet fraction are shown in Figures 6 and 7. The results of the statistical analysis of the pelleting of PGK is presented in table 4. The pelleting of PGK decreased with the addition of salt in the presence of both F-actin and PEG both for samples containing purified enzyme and samples containing myogen. The sedimentation of PGK with F-actin increased in the presence of PEG both for samples containing purified enzyme and samples prepared with myogen. The pelleting of PGK increased with PEG in the presence of F-actin. Although the pelleting of myogen PGK in the presence of both F-actin and PEG and absence of KCl was slightly higher than the pelleting of purified enzyme, no significant differences between samples prepared with myogen and those prepared with purified enzyme were evident.

The results of the statistical analysis of the pelleting of enolase is presented in table 5. Although the pelleting of enolase decreased with increasing KCl concentrations in all cases, significant decreases were only apparent for samples containing purified enzyme in the presence of F-actin and absence of PEG, and for samples prepared with myogen in the presence of PEG with or without F-actin. F-actin increased the pelleting of enolase in all cases, with significant increases observed for purified

enzyme in the absence of salt, and for myogen preparations in the presence of PEG and absence of salt. PEG only increased the pelleting of enolase in the myogen preparation in the absence of KCl, and has no effect on the pelleting in samples containing purified enolase. This effect of PEG is also reflected in the statistics comparing samples prepared with purified enzyme to those prepared with myogen which showed differences in the presence of PEG.

### PHOSPHOGLYCERATE KINASE

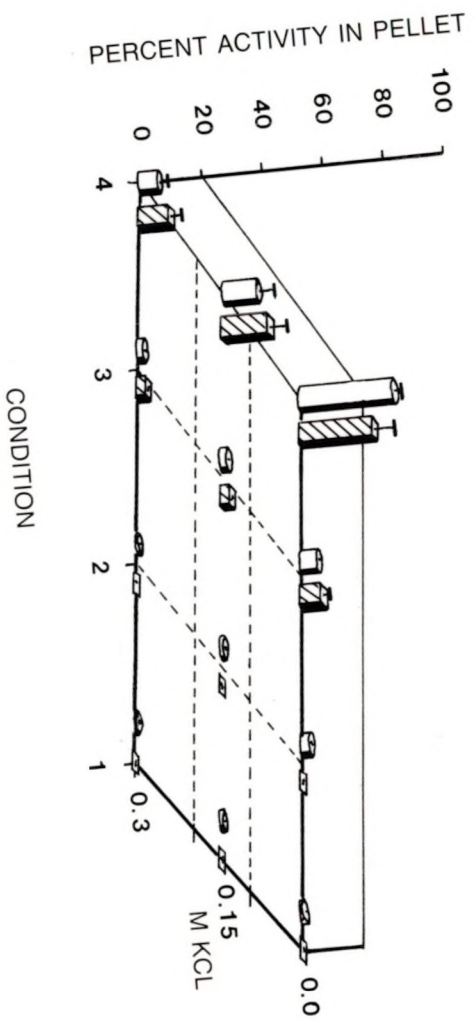

### ENOLASE

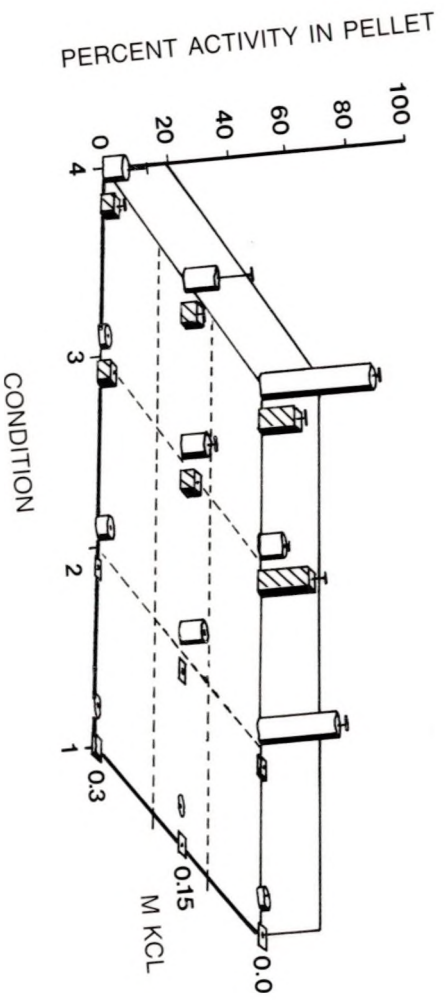



Table 4. Results of the statistical analysis of the pelleting of PGK. The results of PGK pelleting as shown in Figure 6 were statistically analyzed as described in the Materials and Methods section.

<u>Effect of KCl (none vs indicated concentration)</u>								
<u>Enzyme:</u>	<u>pure</u>				<u>myogen</u>			
<u>Condition:</u>	<u>1</u>	<u>2</u>	<u>3</u>	<u>4</u>	<u>1</u>	<u>2</u>	<u>3</u>	<u>4</u>
<u>Salt</u>								
0.15 M	ns	ns	ns	ns	ns	ns	ns	**
0.30 M	ns	ns	ns	**	ns	ns	ns	**

<u>Effect of F-actin (presence vs absence)</u>					
<u>Enzyme:</u>	<u>pure</u>			<u>myogen</u>	
<u>PEG:</u>	<u>0%</u>		<u>14%</u>	<u>0%</u>	<u>14%</u>
<u>Condition:</u>	<u>1,3</u>		<u>2,4</u>	<u>1,3</u>	<u>2,4</u>
<u>Salt</u>					
0 M	ns		**	ns	**
0.15 M	ns		**	ns	ns
0.30 M	ns		ns	ns	ns

<u>Effect of PEG (0 vs 14%)</u>				
<u>Enzyme:</u>	<u>pure</u>		<u>myogen</u>	
<u>Protein:</u>	<u>F-actin</u>	<u>none</u>	<u>F-actin</u>	<u>none</u>
<u>Condition:</u>	<u>3,4</u>	<u>1,2</u>	<u>3,4</u>	<u>1,2</u>
<u>Salt</u>				
0 M	**	ns	**	ns
0.15 M	*	ns	ns	ns
0.30 M	ns	ns	ns	ns

<u>Effect of Myogen (pure vs myogen)</u>				
<u>Actin:</u>	<u>none</u>		<u>300 <math>\mu</math>g</u>	
<u>PEG:</u>	<u>0</u>	<u>14%</u>	<u>0</u>	<u>14%</u>
<u>Condition:</u>	<u>1</u>	<u>2</u>	<u>3</u>	<u>4</u>
<u>Salt</u>				
0 M	ns	ns	ns	ns
0.15 M	ns	ns	ns	ns
0.30 M	ns	ns	ns	ns

Table 5. Results of the statistical analysis of the pelleting of enolase. The results of enolase pelleting as shown in Figure 7 were statistically analyzed as described in the Materials and Methods section.

<u>Effect of KCl (none vs indicated concentration)</u>									
<u>Enzyme:</u>		<u>pure</u>				<u>myogen</u>			
<u>Condition:</u>		<u>1</u>	<u>2</u>	<u>3</u>	<u>4</u>	<u>1</u>	<u>2</u>	<u>3</u>	<u>4</u>
<u>Salt</u>									
0.15 M		ns	ns	**	ns	ns	**	ns	**
0.30 M		ns	ns	**	ns	ns	**	ns	**

<u>Effect of F-actin (presence vs absence)</u>					
<u>Enzyme:</u>		<u>pure</u>		<u>myogen</u>	
<u>PEG:</u>		<u>0%</u>	<u>14%</u>	<u>0%</u>	<u>14%</u>
<u>Condition:</u>		<u>1,3</u>	<u>2,4</u>	<u>1,3</u>	<u>2,4</u>
<u>Salt</u>					
0	M	**	*	ns	*
0.15	M	ns	ns	ns	ns
0.30	M	ns	ns	ns	ns

<u>Effect of PEG (0 vs 14%)</u>					
<u>Enzyme:</u>		<u>pure</u>		<u>myogen</u>	
<u>Protein:</u>		<u>F-actin</u>	<u>none</u>	<u>F-actin</u>	<u>none</u>
<u>Condition:</u>		<u>2,4</u>	<u>1,4</u>	<u>2,4</u>	<u>1,4</u>
<u>Salt</u>					
0	M	ns	ns	**	**
0.15	M	ns	ns	ns	ns
0.30	M	ns	ns	ns	ns

<u>Effect of Myogen (pure vs myogen)</u>					
<u>Actin</u>		<u>none</u>		<u>300 <math>\mu</math>g</u>	
<u>PEG:</u>		<u>0</u>	<u>14%</u>	<u>0</u>	<u>14%</u>
<u>Condition:</u>		<u>1</u>	<u>2</u>	<u>3</u>	<u>4</u>
<u>Salt</u>					
0	M	ns	**	ns	**
0.15	M	ns	ns	ns	ns
0.30	M	ns	ns	ns	ns

GPI

The percentages of GPI found in the pellet fraction are plotted in Figure 8 and the results of the statistical analysis of that pelleting is shown in table 6. Sedimentation decreased with the addition of KCl in the presence of both F-actin and PEG both for samples containing purified enzyme and for samples containing myogen. F-actin increased the pelleting in samples containing purified enzyme in the presence of PEG under all concentrations of KCl, and the pelleting of enzyme in samples prepared with myogen in the presence of PEG and absence of KCl. PEG increased the pelleting of GPI in samples containing purified enzyme in the presence of F-actin and for samples prepared with myogen in both the presence and absence of F-actin.

Since more than 50 percent of GPI activity was found in the pellet fraction in the presence of both F-actin and PEG and absence of salt, the protein specificity for cosedimentation was tested. TPI pelleted the least of all glycolytic enzymes, therefore, it was used as the control protein. More GPI pelleted in the presence of F-actin when compared to TPI for samples containing purified enzyme in the absence of PEG and salt, and in the presence of PEG at all salt concentrations. A higher percentage of activity pelleted in samples prepared with myogen than in those prepared with purified enzyme in the presence of PEG and absence of KCl.



Table 6. Results of the statistical analysis of the pelleting of GPI. The results of GPI pelleting as shown in Figure 8 were statistically analyzed as described in the Materials and Methods section.

<u>Effect of KCl (none vs indicated concentration)</u>										
Enzyme:	pure				myogen				pure + TPI	
Condition:	<u>1</u>	<u>2</u>	<u>3</u>	<u>4</u>	<u>1</u>	<u>2</u>	<u>3</u>	<u>4</u>	<u>3</u>	<u>4</u>
Salt										
0.15 M	ns	ns	ns	**	ns	ns	ns	**	ns	ns
0.30 M	ns	ns	ns	**	ns	ns	ns	**	ns	ns

<u>Effect of F-actin (presence vs absence)</u>					
Enzyme:	pure		myogen		
PEG:	<u>0%</u>	<u>14%</u>	<u>0%</u>	<u>14%</u>	
Condition:	<u>1,3</u>	<u>2,4</u>	<u>1,3</u>	<u>2,4</u>	
Salt					
0 M	ns	**	ns	**	
0.15 M	ns	**	ns	ns	
0.30 M	ns	**	ns	ns	

<u>Effect of PEG (0 vs 14%)</u>						
Enzyme:	pure		myogen		pure	
Protein:	<u>F-actin</u>	<u>none</u>	<u>F-actin</u>	<u>none</u>	<u>TPI</u>	
Condition:	<u>3,4</u>	<u>1,2</u>	<u>3,4</u>	<u>1,2</u>		
Salt						
0 M	**	ns	**	**	ns	
0.15 M	ns	ns	**	ns	ns	
0.30 M	ns	ns	ns	ns	ns	

<u>Protein Specificity (F-actin vs TPI)</u>				
Enzyme:	pure			
PEG:	<u>0</u>	<u>14%</u>		
Condition:	<u>3</u>	<u>4</u>		
Salt				
0 M	*	**		
0.15 M	ns	*		
0.30 M	ns	**		

<u>Effect of Myogen (pure vs myogen)</u>				
Actin:	none		300 $\mu$ g	
PEG:	<u>0</u>	<u>14%</u>	<u>0</u>	<u>14%</u>
Condition:	<u>1</u>	<u>2</u>	<u>3</u>	<u>4</u>
Salt				
0 M	ns	**	ns	ns
0.15 M	ns	ns	ns	ns
0.30 M	ns	ns	ns	ns

Aldolase and GAPDH

As shown in Figures 9 and 10, the pelleting of aldolase and GAPDH increased with the addition of F-actin and/or PEG and usually decreased with the addition of salt. Both enzymes pelleted greater than 50 percent in the presence of both F-actin and PEG and absence of salt and therefore, were tested for protein specificity of cosedimentation using TPI as a control protein. The results of the statistical analysis of the pelleting of aldolase is shown in table 7 and of the pelleting of GAPDH is shown in table 8.

Aldolase was partially solubilized with the addition of KCl under all conditions except for samples containing purified enzyme in the presence of both F-actin and PEG. Slight increases in sedimentation which were insignificant were observed on the addition of KCl in samples containing purified aldolase, F-actin, and PEG. The addition of KCl decreased the pelleting in samples containing purified aldolase in the presence of F-actin, and in samples containing myogen in the presence of PEG with or without F-actin. F-actin increased the amount of aldolase activity found in the pellet for samples prepared with purified enzyme and for samples prepared with myogen in the presence of PEG at all salt concentrations, and for samples containing purified enzyme in the absence of both PEG and KCl. The presence of PEG increased the pelleting of

purified aldolase in the presence of F-actin and KCl, and in the presence of TPI and absence of KCl. PEG also increased the pelleting of aldolase in samples containing the myogen preparation in the presence of F-actin at all salt concentrations, and in the absence of F-actin and KCl. More aldolase in samples prepared with purified enzyme pelleted in the presence of F-actin than in the presence of TPI when in the presence of PEG, and in the absence of PEG and KCl. Comparison of samples containing myogen to those containing purified aldolase reveals variability in the extent of pelleting. In the presence of PEG, absence of F-actin, and absence of KCl, a higher percentage of enzyme activity pelleted in samples prepared with myogen than in samples prepared with purified enzyme. Less enzyme activity pelleted in samples containing myogen than in those containing purified enzyme in the presence of PEG, F-actin, and 0.30 M KCl, and in the presence of F-actin and absence of PEG and KCl.

The pelleting of GAPDH decreased with the addition of KCl under all conditions except where the pelleting of GAPDH in the absence of KCl was less than or equal to 12 percent (samples containing purified enzyme in either the presence of PEG or TPI, and samples containing purified enzyme and samples containing myogen in the absence of both F-actin and PEG). Although the presence of F-actin generally increased the pelleting of GAPDH, differences

were demonstrated only for purified enzyme in the presence of PEG or in the absence of KCl. The presence of PEG increased the percentage of GAPDH found in the pellet fraction in the presence of F-actin in samples containing either the purified enzyme or the myogen preparation. PEG also increased pelleting in the absence of F-actin for samples containing myogen with 0 and 0.15 M KCl, and for samples containing purified GAPDH with TPI but without salt. The greatest difference between samples containing myogen and purified GAPDH was demonstrated in the presence of PEG and absence of KCl. A higher percentage of GAPDH activity in samples prepared with myogen than in samples prepared with purified enzyme pelleted in the presence of PEG at 0 and 0.15 M KCl, while more pelleted in samples prepared with purified GAPDH than those prepared with myogen in the presence of F-actin and absence of KCl.



### ALDOLASE

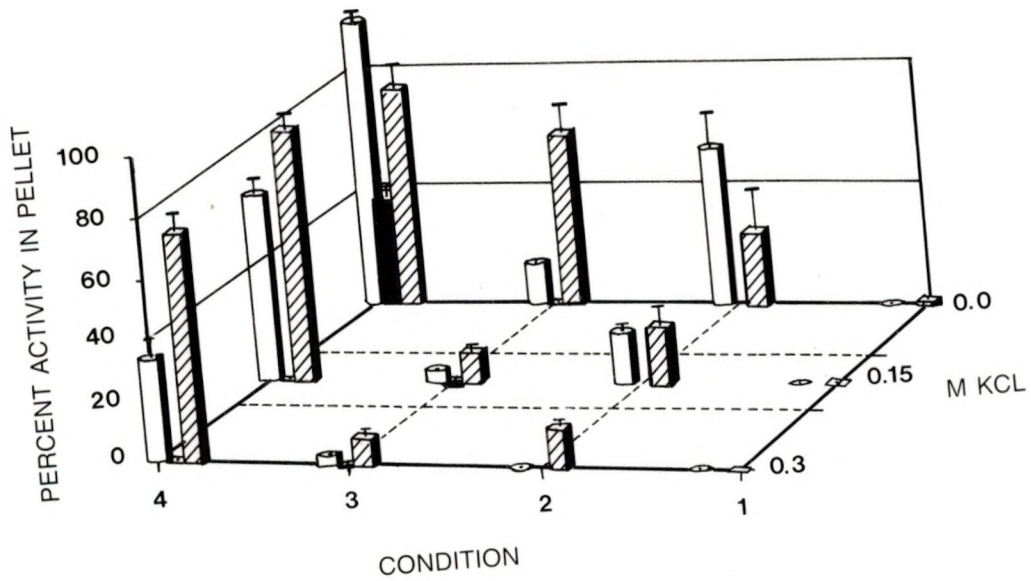

### GLYCERALDEHYDE-3-PHOSPHATE DEHYDROGENASE

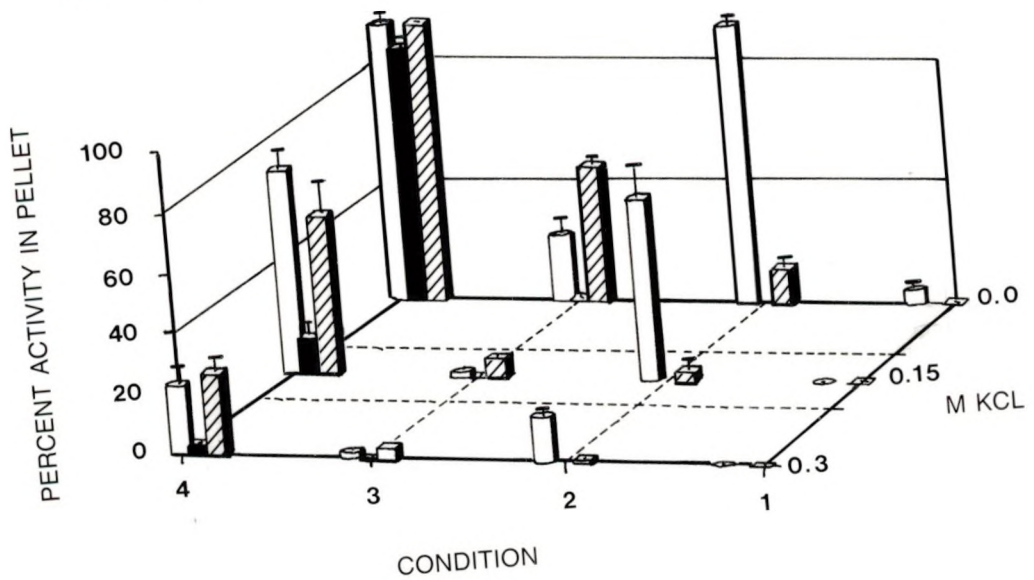

Table 7. Results of the statistical analysis of the pelleting of aldolase. The results of aldolase pelleting as shown in Figure 9 were statistically analyzed as described in the Materials and Methods section.

Effect of KCl (none vs indicated concentration)

Enzyme:	pure				myogen				pure + TPI	
	<u>1</u>	<u>2</u>	<u>3</u>	<u>4</u>	<u>1</u>	<u>2</u>	<u>3</u>	<u>4</u>	<u>3</u>	<u>4</u>
Salt										
0.15 M	ns	ns	**	ns	ns	**	ns	**	ns	*
0.30 M	ns	ns	**	ns	ns	**	ns	**	ns	*

Effect of F-actin (presence vs absence)

Enzyme:	pure		myogen	
	<u>0%</u>	<u>14%</u>	<u>0%</u>	<u>14%</u>
PEG:				
Condition:	<u>1,3</u>	<u>2,4</u>	<u>1,3</u>	<u>2,4</u>
Salt				
0 M	**	**	ns	**
0.15 M	ns	**	ns	**
0.30 M	ns	**	ns	**

Enzyme:	pure		myogen		pure TPI
	<u>F-actin</u>	<u>none</u>	<u>F-actin</u>	<u>none</u>	
Protein:					
Condition:	<u>3,4</u>	<u>1,2</u>	<u>3,4</u>	<u>1,2</u>	
salt					
0 M	ns	ns	**	**	**
0.15 M	**	ns	**	ns	ns
0.30 M	**	ns	**	ns	ns

Protein Specificity (F-actin vs TPI)

Enzyme:	pure	
	<u>0</u>	<u>14%</u>
PEG:		
Condition:	<u>3</u>	<u>4</u>
salt		
0 M	**	**
0.15 M	ns	**
0.30 M	ns	**

Effect of Myogen (pure vs myogen)

Actin:	none		300 $\mu$ g	
	<u>0</u>	<u>14%</u>	<u>0</u>	<u>14%</u>
PEG:				
Condition:	<u>1</u>	<u>2</u>	<u>3</u>	<u>4</u>
salt				
0 M	ns	**	**	*
0.15 M	ns	ns	ns	ns
0.30 M	ns	ns	ns	**

Table 8. Results of the statistical analysis of the pelleting of GAPDH. The results of GAPDH pelleting as shown in Figure 10 were statistically analyzed as described in the Materials and Methods section.

Effect of KCl (none vs indicated concentration)

Enzyme:	pure				myogen				pure + TPI	
	<u>1</u>	<u>2</u>	<u>3</u>	<u>4</u>	<u>1</u>	<u>2</u>	<u>3</u>	<u>4</u>	<u>3</u>	<u>4</u>
Condition:										
Salt										
0.15 M	ns	ns	**	**	ns	**	*	**	ns	**
0.30 M	ns	ns	**	**	ns	**	*	**	ns	**

Effect of F-actin (presence vs absence)

Enzyme:	pure		myogen	
	<u>0%</u>	<u>14%</u>	<u>0%</u>	<u>14%</u>
Condition:	<u>1,3</u>	<u>2,4</u>	<u>1,3</u>	<u>2,4</u>
Salt				
0 M	**	**	ns	ns
0.15 M	ns	**	ns	ns
0.30 M	ns	**	ns	ns

Effect of PEG (0 vs 14%)

Enzyme:	pure		myogen		pure TPI
	<u>F-actin</u>	<u>none</u>	<u>F-actin</u>	<u>none</u>	
Condition:	<u>3,4</u>	<u>1,2</u>	<u>3,4</u>	<u>1,2</u>	
salt					
0 M	**	ns	**	**	**
0.15 M	**	ns	**	**	ns
0.30 M	*	ns	*	ns	ns

Protein Specificity (F-actin vs TPI)

Enzyme:	pure	
	<u>0</u>	<u>14%</u>
Condition:	<u>3</u>	<u>4</u>
salt		
0 M	**	ns
0.15 M	ns	**
0.30 M	ns	**

Effect of Myogen (pure vs myogen)

Actin:	none		300 $\mu$ g	
	<u>0</u>	<u>14%</u>	<u>0</u>	<u>14%</u>
Condition:	<u>1</u>	<u>2</u>	<u>3</u>	<u>4</u>
salt				
0 M	ns	**	**	ns
0.15 M	ns	**	ns	ns
0.30 M	ns	ns	ns	ns

PK and LDH

The pelleting of PK and LDH followed the normal pattern of increasing in the presence of F-actin and/or PEG and decreasing with the addition of KCl. However, a large percentage of activity found in the pellet fraction suggested that 14 percent PEG may have caused precipitation of these enzymes. Therefore, both purified and myogen PK and LDH were tested for pelleting under the usual conditions not only in the presence of 14 percent PEG but also in the presence of 11 percent PEG, as shown in Figures 11 and 12 and tables 9 and 11. The results of the statistical analyses of the pelleting are shown in tables 10, 12, 13, and 14.

The pelleting of PK decreased with the addition of KCl for samples containing purified enzyme under all conditions except either in the absence of both F-actin and PEG, in the presence of both F-actin and 14 percent PEG, or in the presence of TPI. The pelleting of PK in samples prepared with myogen decreased with increased KCl in the presence of either 11 percent or 14 percent PEG with or without the addition of F-actin. F-actin increased the pelleting of PK both for samples containing purified enzyme and those containing myogen in the absence of PEG and KCl. Pelleting in samples containing purified enzyme increased with the addition of F-actin in the presence of 11 percent PEG at 0 and 0.15 M KCl and in the presence of 14 percent PEG at

0.15 and 0.30 M KCl. F-actin also increased the pelleting in samples prepared with myogen in the presence of 14 percent PEG at 0.15 and 0.30 M KCl.

PEG at 11 percent increased the percentage of PK found in the pellet fraction both for samples containing purified enzyme and for samples prepared with myogen under all conditions in the absence of added salt, in the presence of F-actin at 0.15 M KCl, and in the presence of TPI and absence of KCl. The pelleting in samples containing myogen increased with the addition of 11 percent PEG in the absence of F-actin and presence of 0.15 M KCl. The presence of 14 percent PEG increased the pelleting in samples prepared both with purified enzyme and with myogen in the presence and absence of F-actin at 0 and 0.15 M KCl. PEG at 14 percent also increased the pelleting of PK in samples prepared with purified enzyme at 0.30 M KCl. The pelleting in samples containing purified PK was greater in the presence of F-actin than in the presence of TPI in either the presence or absence of 11 percent PEG and the absence of KCl. The pelleting of PK in samples prepared with purified enzyme and those prepared with myogen was very similar, with only one difference which occurred in the presence of 11 percent PEG and absence of both F-actin and KCl.

The addition of KCl generally decreased the percentage of LDH found in the pellet fraction. Reduction in pelleting

was achieved in samples containing purified enzyme in the presence of F-actin with or without either 11 or 14 percent PEG, in the absence of F-actin and presence of 14 percent PEG, and in the presence of both TPI and 11 percent PEG. Sedimentation was also reduced in samples containing the myogen preparation in the presence of either 11 or 14 percent PEG with or without F-actin.

F-actin increased the percentage of LDH found in the pellet fraction for samples containing purified enzyme in either the absence of both PEG and KCl, in the presence of 11 percent PEG at 0 and 0.15 M KCl, or in the presence of 14 percent PEG at all salt concentrations. Samples prepared with myogen showed an increase in pelleting with the addition of F-actin in the presence of 14 percent PEG at 0.15 and 0.30 M KCl.

PEG at 11 percent increased the percentage of LDH found in the pellet fraction for samples containing purified enzyme in the absence of salt and the presence of either F-actin or TPI. PEG at 11 percent also increased the pelleting of LDH in samples containing myogen in the presence or absence of F-actin and absence of KCl. Pelleting increased with the addition of PEG at 14 percent both for samples prepared with purified enzyme and those prepared with myogen in the presence of F-actin at all salt concentrations and in the absence of both F-actin and KCl. An increase in pelleting with the addition of 14 percent

PEG was also evident in samples prepared with myogen at 0.15 M KCl. Greater pelleting of purified LDH was demonstrated in the presence of F-actin and absence of KCl than in the presence of TPI and absence of KCl. Samples prepared with myogen showed a greater percentage of LDH in the pellet fraction than samples containing purified enzyme in the presence of either 11 or 14 percent PEG and the absence of F-actin.

---

Table 9. Percentages of the total activities of PK found in the pellet fraction at 14 percent PEG. Samples were prepared as described in the Materials and Methods section. Values represent means  $\pm$  S.E.

---

	<u>Condition 2<sup>a</sup></u>		<u>Condition 4<sup>b</sup></u>	
	<u>Purified</u>	<u>Myogen</u>	<u>Purified</u>	<u>Myogen</u>
<u>M KCl</u>				
0	90 $\pm$ 6	95 $\pm$ 3	86 $\pm$ 6	100 $\pm$ 0
0.15	46 $\pm$ 14	56 $\pm$ 10	98 $\pm$ 0.3	93 $\pm$ 3
0.30	17 $\pm$ 5	26 $\pm$ 6	91 $\pm$ 3	71 $\pm$ 6

<sup>a</sup> Condition 2 represents the presence of 14 percent PEG.

<sup>b</sup> Condition 4 represents the presence of both F-actin and 14 percent PEG.

Table 10. Results of the statistical analysis of the pelleting of PK at 14 percent PEG. The results of the pelleting of PK as shown in Figure 11 (conditions 1 and 3) and in table 9 were statistically analyzed as described in the Materials and Methods section.

Effect of KCl (none vs indicated concentration)

Enzyme:	pure				myogen			
	1	2	3	4	1	2	3	4
Salt								
0.15 M	ns	**	**	ns	ns	**	ns	ns
0.30 M	ns	**	**	ns	ns	**	ns	*

Effect of F-actin (presence vs absence)

Enzyme:	pure		myogen	
	0%	14%	0%	14%
PEG:				
Condition:	1,3	2,4	1,3	2,4
Salt				
0 M	**	ns	*	ns
0.15 M	ns	**	ns	**
0.30 M	ns	**	ns	**

Effect of PEG (0 vs 14%)

Enzyme:	pure		myogen	
	F-actin	none	F-actin	none
Protein:				
Condition:	3,4	1,2	3,4	1,2
Salt				
0 M	**	**	**	**
0.15 M	**	**	**	**
0.30 M	**	ns	**	ns

Effect of Myogen (pure vs myogen)

Actin:	none		300 $\mu$ g	
	0	14%	0	14%
PEG:				
Condition:	1	2	3	4
Salt				
0 M	ns	ns	ns	ns
0.15 M	ns	ns	ns	ns
0.30 M	ns	ns	ns	ns



Table 11. Percentage of the total activities of LDH found in the pellet fraction at 14 percent PEG. Values represent means  $\pm$  S.E.

	<u>Condition 2<sup>a</sup></u>		<u>Condition 4<sup>b</sup></u>	
	<u>Purified</u>	<u>Myogen</u>	<u>Purified</u>	<u>Myogen</u>
<u>M KCl</u>				
0	35 $\pm$ 17	96 $\pm$ 3	99 $\pm$ 3	100 $\pm$ 0.1
0.15	35 $\pm$ 8	37 $\pm$ 2	90 $\pm$ 3	87 $\pm$ 2
0.30	5 $\pm$ 0.4	10 $\pm$ 0.8	40 $\pm$ 8	56 $\pm$ 6

<sup>a</sup> Condition 2 represents the presence of 14 percent PEG.

<sup>b</sup> Condition 4 represents the presence of both F-actin and 14 percent PEG.

Table 12. Results of the statistical analysis of the pelleting of LDH at 14 percent PEG. The results of the pelleting of LDH as shown in Figure 12 (conditions 1 and 3) and in table 11 were statistically analyzed as described in the Materials and Methods section.

Effect of KCl (none vs indicated concentration)

Enzyme:	pure				myogen			
	1	2	3	4	1	2	3	4
Condition:								
Salt								
0.15 M	ns	ns	**	ns	ns	**	ns	ns
0.30 M	ns	*	**	**	ns	**	ns	**

Effect of F-actin (presence vs absence)

Enzyme:	pure		myogen	
	0%	14%	0%	14%
Condition:	1,3	2,4	1,3	2,4
Salt				
0 M	**	**	ns	ns
0.15 M	ns	**	ns	**
0.30 M	ns	**	ns	**

Effect of PEG (0 vs 14%)

Enzyme:	pure		myogen	
	F-actin	none	F-actin	none
Condition:	3,4	1,2	3,4	1,2
Salt				
0 M	**	*	**	**
0.15 M	**	ns	**	**
0.30 M	**	ns	**	ns

Effect of Myogen (pure vs myogen)

Actin:	none		300 $\mu$ g	
	0	14%	0	14%
Condition:	1	2	3	4
Salt				
0 M	ns	**	ns	ns
0.15 M	ns	ns	ns	ns
0.30 M	ns	ns	ns	ns

## PYRUVATE KINASE

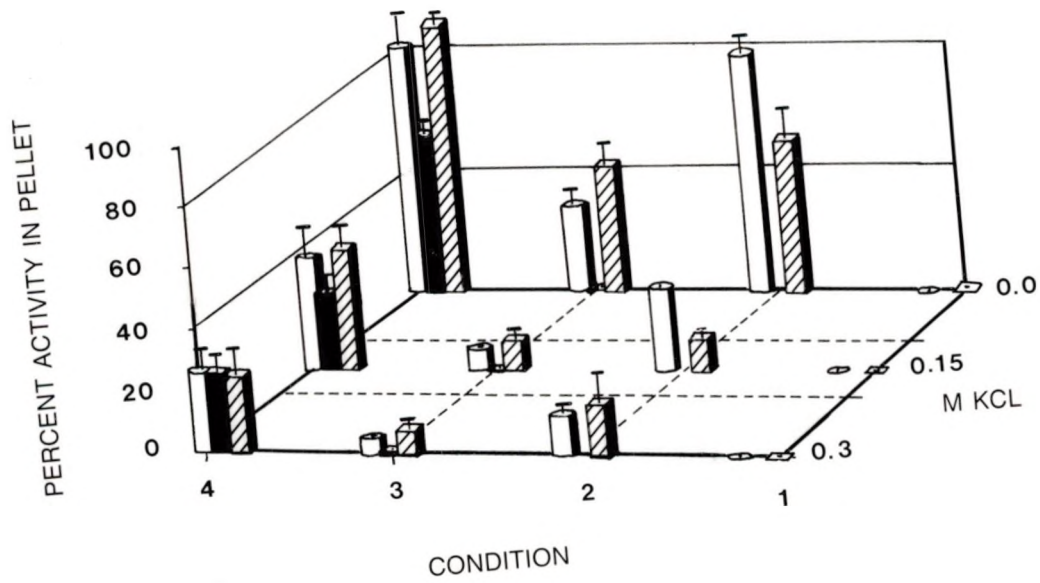

## LACTATE DEHYDROGENASE

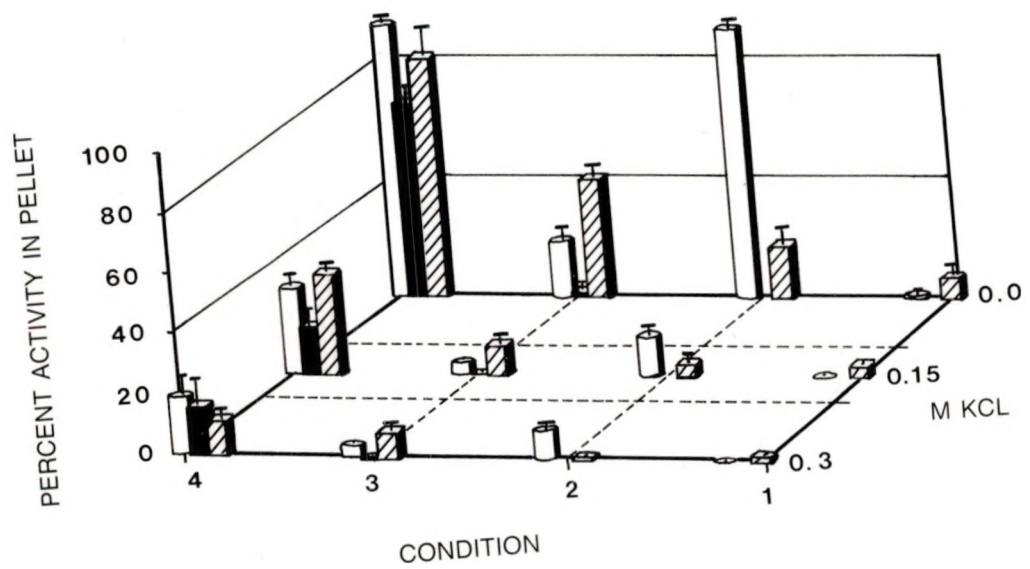

Table 13. Results of the statistical analysis of the pelleting of PK at 11 percent PEG. The results of PK pelleting as shown in Figure 11 were statistically analyzed as described in the Materials and Methods section.

Effect of KCl (none vs indicated concentration)

Enzyme:	pure				myogen				pure + TPI	
	<u>1</u>	<u>2</u>	<u>3</u>	<u>4</u>	<u>1</u>	<u>2</u>	<u>3</u>	<u>4</u>	<u>3</u>	<u>4</u>
Salt										
0.15 M	ns	**	**	**	ns	**	ns	**	ns	*
0.30 M	ns	**	**	**	ns	**	ns	**	ns	*

Effect of F-actin (presence vs absence)

Enzyme:	pure		myogen	
	<u>0%</u>	<u>11%</u>	<u>0%</u>	<u>11%</u>
Condition:	<u>1,3</u>	<u>2,4</u>	<u>1,3</u>	<u>2,4</u>
Salt				
0 M	**	**	*	ns
0.15 M	ns	*	ns	ns
0.30 M	ns	ns	ns	ns

Effect of PEG (0 vs 11%)

Enzyme:	pure		myogen		pure TPI
	<u>F-actin</u>	<u>none</u>	<u>F-actin</u>	<u>none</u>	
Condition:	<u>3,4</u>	<u>1,2</u>	<u>3,4</u>	<u>1,2</u>	
Salt					
0 M	**	**	**	**	**
0.15 M	*	ns	*	*	ns
0.30 M	ns	ns	ns	ns	ns

Enzyme:	pure	
PEG:	<u>0</u>	<u>11%</u>
Condition:	<u>3</u>	<u>4</u>
Salt		
0 M	**	**
0.15 M	ns	ns
0.30 M	ns	ns

Effect of Myogen (pure vs myogen)

Actin:	none		300 $\mu$ g	
	<u>0</u>	<u>11%</u>	<u>0</u>	<u>11%</u>
Condition:	<u>1</u>	<u>2</u>	<u>3</u>	<u>4</u>
Salt				
0 M	ns	**	ns	ns
0.15 M	ns	ns	ns	ns
0.30 M	ns	ns	ns	ns

Table 14. Results of the statistical analysis of the pelleting of LDH at 11 percent PEG. The results of LDH pelleting as shown in Figure 12 were statistically analyzed as described in the Materials and Methods section.

<u>Effect of KCl (none vs indicated concentration)</u>										
Enzyme:	pure				myogen				pure + TPI	
Condition:	<u>1</u>	<u>2</u>	<u>3</u>	<u>4</u>	<u>1</u>	<u>2</u>	<u>3</u>	<u>4</u>	<u>3</u>	<u>4</u>
Salt										
0.15 M	ns	ns	**	**	ns	**	ns	**	ns	**
0.30 M	ns	ns	**	**	ns	**	ns	**	ns	**

<u>Effect of F-actin (presence vs absence)</u>					
Enzyme:	pure			myogen	
PEG:	<u>0%</u>		<u>11%</u>	<u>0%</u>	<u>11%</u>
Condition:	<u>1,3</u>		<u>2,4</u>	<u>1,3</u>	<u>2,4</u>
Salt					
0 M	**		**	ns	ns
0.15 M	ns		**	ns	ns
0.30 M	ns		ns	ns	ns

<u>Effect of PEG (0 vs 11%)</u>						
Enzyme:	pure		myogen		pure	
Protein:	<u>F-actin</u>		<u>F-actin</u>		<u>TPI</u>	
Condition:	<u>3,4</u>		<u>3,4</u>		<u>1,2</u>	
salt						
0 M	**	ns	**	**	**	
0.15 M	ns	ns	ns	ns	ns	
0.30 M	ns	ns	ns	ns	ns	

<u>Protein Specificity (F-actin vs TPI)</u>			
Enzyme:	pure		
PEG:	<u>0</u>	<u>11%</u>	
Condition:	<u>3</u>	<u>4</u>	
salt			
0 M	**	ns	
0.15 M	ns	ns	
0.30 M	ns	ns	

<u>Effect of Myogen (pure vs myogen)</u>				
Actin:	none		300 $\mu$ g	
PEG:	<u>0</u>	<u>11%</u>	<u>0</u>	<u>11%</u>
Condition:	<u>1</u>	<u>2</u>	<u>3</u>	<u>4</u>
salt				
0 M	ns	**	ns	ns
0.15 M	ns	ns	ns	ns
0.30 M	ns	ns	ns	ns

The Pelleting of Purified Glycolytic Enzymes in the Presence of Other Purified Glycolytic Enzymes and PEG

In some cases, a larger percentage of enzyme activity pelleted in samples prepared with myogen than in samples prepared with purified enzymes in the presence of PEG and absence of F-actin. Such a result will be interpreted as indicating an interaction between the enzyme and some other protein in the myogen preparation. Since enolase, GPI, aldolase, GAPDH, and LDH pelleted 25 percent more in samples prepared with myogen than in samples prepared with purified enzyme, these enzymes were tested for pelleting with each other and with PK and PFK which also were present in myogen but not with themselves. As Figure 13, table 15, and the statistical analysis in table 16 show, the sedimentation of the glycolytic enzymes tested was affected to varying degrees by the presence of other glycolytic enzymes with the exception of LDH.

GAPDH, aldolase, GPI, and enolase pelleted more in the presence of PFK than in the presence of at least one other enzyme. For GAPDH, pelleting in the presence of PFK was greater than in the presence of either aldolase or LDH. Aldolase pelleted the most in the presence of either LDH or PK, an intermediate amount pelleted in the presence of either PFK or GAPDH, and the least amount pelleted in the presence of either GPI or enolase. Differences were noted between the pelleting of aldolase in the presence of GAPDH, LDH, PK, or PFK compared to the presence of enolase, and

pelleting in the presence of LDH and PK compared to GPI.

GPI sedimented the most in the presence of PFK. Differences were demonstrated in the sedimentation of GPI when pelletting in the presence of PFK was compared to pelletting in the presence of each of the other glycolytic enzymes tested. Enolase demonstrated the most pelletting in the presence of PFK, an intermediate amount of pelletting in the presence of PK, and the least amount of pelletting in the presence of LDH, GAPDH, or aldolase. Differences in the pelletting of enolase were evident when pelletting in the presence of PFK was compared to pelletting in the presence of either aldolase, GAPDH, or LDH. LDH also demonstrated the greatest pelletting in the presence of PFK (table 15). However, no significant differences were evident on comparison of the amounts of LDH activity found in the pellet fraction in the presence of the various glycolytic enzymes tested.

---

Table 15. Percents of the total activities of purified LDH found in the pellet fraction when prepared in combination with other purified glycolytic enzymes and 14 percent PEG. Samples were prepared as described in the Materials and Methods section. Values are means  $\pm$  S.E.

---

<u>Combination Enzyme</u>	<u>Percent LDH in Pellet</u>
Enol	78 $\pm$ 9
GPI	76 $\pm$ 7
Ald	67 $\pm$ 3
GAPDH	64 $\pm$ 8
PK	75 $\pm$ 13
PFK	92 $\pm$ 3

---

# ENZYME - ENZYME INTERACTIONS

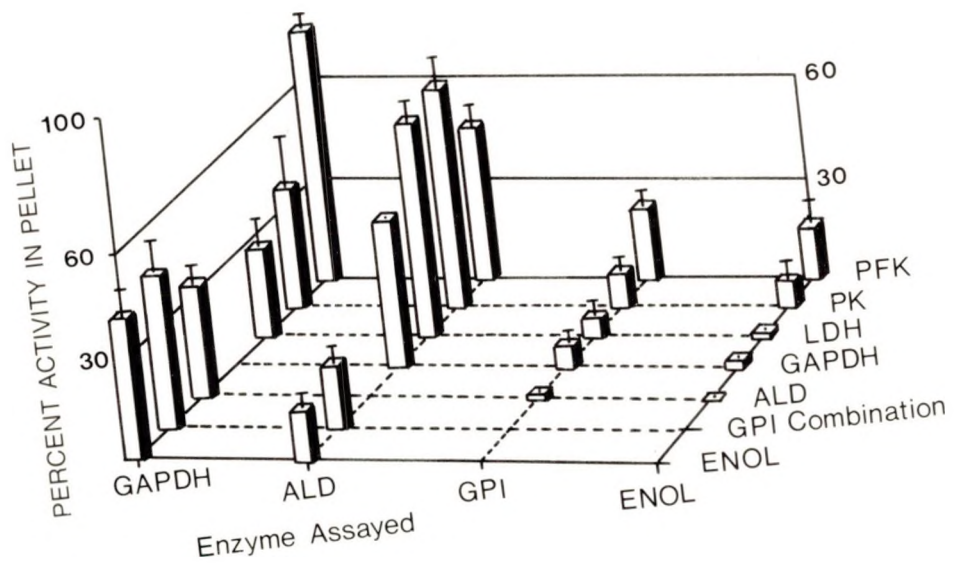



Table 16. Results of the statistical analysis of the pelleting of purified glycolytic enzymes in the presence of other purified glycolytic enzymes and 14 percent PEG. The enzyme assayed is represented in the heading and the combination enzymes are represented horizontally (a) and vertically (b). The values represent differences in the amount of the enzyme assayed found in the pellet fraction when in combination with enzyme a compared to pelleting when in combination with enzyme b. The results were statistically analyzed as described in the Materials and Methods section.

		<u>GAPDH</u>					
<u>b</u> \a:	Enol	GPI	Ald	LDH	PK	PFK	
Enol	-	ns	ns	ns	ns	ns	ns
GPI	-	-	ns	ns	ns	ns	ns
Ald	-	-	-	ns	ns	*	
LDH	-	-	-	-	ns	*	
PK	-	-	-	-	-	ns	

		<u>Aldolase</u>					
<u>b</u> \a:	Enol	GPI	GAPDH	LDH	PK	PFK	
Enol	-	ns	*	**	**	*	
GPI	-	-	ns	**	**	ns	
GAPDH	-	-	-	ns	ns	ns	
LDH	-	-	-	-	ns	ns	
PK	-	-	-	-	-	ns	

		<u>GPI</u>				
<u>b</u> \a:	Ald	GAPDH	LDH	PK	PFK	
Ald	-	ns	ns	ns	**	
GAPDH	-	-	ns	ns	**	
LDH	-	-	-	ns	**	
PK	-	-	-	-	*	

		<u>Enolase</u>				
<u>b</u> \a:	Ald	GAPDH	LDH	PK	PFK	
Ald	-	ns	ns	ns	*	
GAPDH	-	-	ns	ns	*	
LDH	-	-	-	ns	*	
PK	-	-	-	-	ns	

		<u>LDH</u>				
<u>b</u> \a:	Enol	GPI	Ald	GAPDH	PK	PFK
Enol	-	ns	ns	ns	ns	ns
GPI	-	-	ns	ns	ns	ns
Ald	-	-	-	ns	ns	ns
GAPDH	-	-	-	-	ns	ns
PK	-	-	-	-	-	ns

Units of Enzyme Activity Per Sample

The units of enzyme activity both for samples containing myogen and for those containing purified enzyme are presented in table 17. The units of activity are quite variable between the purified enzyme and myogen preparation. Samples containing more units of purified enzyme activity than samples prepared with myogen are those containing GAPDH, which has an 18-fold difference, GPI, which has a 14-fold difference, and TPI, which shows a 7-fold difference. Samples containing more units of activity in myogen than purified enzyme preparations are aldolase which has a 12-fold difference, LDH and PK with 2-fold differences, enolase which has a 3-fold difference, and PGM with an 8-fold difference. PGK demonstrated approximately equal units of activity in samples containing purified enzyme and the myogen preparation.

Table 17. Units of enzyme activity per sample. Samples were prepared and units were calculated as described in the Materials and Methods section. Values represent means  $\pm$  S.E.

Preparation: <u>Enzyme</u>	<u>pure</u>	<u>myogen</u>
GAPDH	0.29 $\pm$ 0.009	0.016 $\pm$ 0.001
Ald	0.068 $\pm$ 0.005	0.80 $\pm$ 0.03
LDH	1.9 $\pm$ 0.1	3.7 $\pm$ 0.2
PK	1.1 $\pm$ 0.07	1.9 $\pm$ 0.08
GPI	2.3 $\pm$ 0.1	0.17 $\pm$ 0.04
Eno1	0.017 $\pm$ 0.001	0.045 $\pm$ 0.007
PGK	0.19 $\pm$ 0.008	0.20 $\pm$ 0.004
PGM	0.24 $\pm$ 0.02	2.0 $\pm$ 0.04
TPI	5.7 $\pm$ 0.2	0.79 $\pm$ 0.02

## DISCUSSION

Textbooks classically consider the glycolytic enzymes as soluble components of the cytoplasm, and the cytoplasm has been depicted as a solution of intracellular components excluding intracellular vesicles and the cytoskeleton. With the increasing evidence for the existence of the microtrabecular lattice, the view of the cytoplasm must change to that of an ordered array of proteins permeating throughout the cytoplasm and in contact with vesicular and cytoskeletal components and the plasma membrane. The glycolytic enzymes must be members of this ordered array. The present study investigated specific interactions, which may occur within the microtrabecular lattice, between the glycolytic enzymes and F-actin and between different glycolytic enzymes and the effects of PEG on these interactions.

### The Pelleting of Glycolytic Enzymes in the Presence or

Interpretations of the results relative to the types of interactions indicated will be followed by application of the interpretation to the actual results obtained for each of the glycolytic enzymes studied. The effect of

increasing the concentration of KCl will be presented first, followed by the effects of protein concentration, the effect of PEG, and the differences between myogen and purified enzymes.

Increasing the concentration of KCl concomitantly increases the ionic strength of the solution and hinders ionic interactions. Reversal of protein associations with an increase in ionic strength has been interpreted as indicating that the interactions are electrostatic in nature (30). Therefore, an increase in the pelleting of a glycolytic enzyme with the addition of F-actin, which decreased with increased ionic strength under at least one set of conditions, is considered to indicate an electrostatic interaction between the enzyme and F-actin.

The pelleting of the enzymes in the presence of TPI probably represents non-specific pelleting due to the 'crowding' effect of increased protein concentration. Therefore, enzymes are considered to demonstrate a specific interaction with F-actin when the percent of enzyme activity pelleting in the presence of F-actin is greater than that pelleting in the presence of TPI.

Increased pelleting in the presence of PEG is probably due to its 'crowding' effect as described in the Introduction. That this effect was decreased with the addition of KCl demonstrates that electrostatic interactions were taking place. If PEG were causing precipitation of the

enzyme due to lack of enough water for solvation of the enzyme, the pelleting should be increased by the addition of salt. Therefore, an increase in the pelleting of enzyme activity in the presence of PEG, compared to its absence, along with a decrease in pelleting on the addition of KCl is interpreted as the promotion of an ionic interaction between proteins by PEG.

Differences in pelleting between samples prepared with myogen and those prepared with purified enzyme will be interpreted as follows: A smaller percent of enzyme activity in the pellet fraction of samples containing myogen than of samples containing purified enzyme suggests competition for a common binding site between the enzyme assayed and the components of myogen. A larger percent of enzyme activity found in the pellet fraction in samples containing myogen than of samples containing purified enzyme indicates interactions of the enzyme assayed with the proteins present in myogen. Such a change occurring only in the presence of F-actin would suggest that F-actin induced 'piggy-back' interactions. While interactions occurring among proteins in the myogen preparation in either the presence or absence of F-actin do not exclude the possibility of 'piggy-back' interactions, their occurrence is not specifically indicated. These interpretations will now be applied to the results obtained for each enzyme studied.

TPI and PGM

Although the overall percentages of TPI and PGM activities found in the pellet fraction are the smallest of all of the glycolytic enzymes studied, differences in pelleting under the various conditions were observed. With respect to the interpretation guidelines presented above, TPI and PGM both demonstrate an ionic interaction with F-actin that is found only in the presence of PEG. The TPI and PGM interactions with F-actin also have been observed with the use of counter-current distribution and affinity chromatography but not by cosedimentation (18,19,22). Virtually no differences are evident when the pelleting of TPI and PGM in samples containing myogen and in samples containing purified enzyme are compared, suggesting that neither enzyme interacts with the components of myogen. These results are surprising in light of the results of other studies. An interaction between TPI and aldolase has been reported by Salerno and Ovadi (48) and by Orosz et al. (49), suggesting that TPI should have pelleted more in the samples containing myogen than in samples containing purified enzyme. PGM also was expected to pellet more in samples prepared with myogen via 'piggy-backing' with LDH since such an interaction has been demonstrated by affinity chromatography (19).

### PGK and Enolase

PGK, along with TPI and PGM, demonstrates an ionic interaction with F-actin in the presence of PEG. This is in agreement with the results obtained by other researchers using counter-current distribution, affinity chromatography, and cosedimentation (18,19,22). Evidently PGK did not participate in interactions with myogen proteins under the conditions tested in the present study. However, PGK may play a vital role in the microtrabecular lattice structure. The lack of an interaction is not altogether surprising, since substrates were not added. Addition of substrates was necessary for the detection of complex formation between halibut muscle and yeast forms of GAPDH and PGK (52,53).

The interactions of enolase are more difficult to interpret. Samples containing the purified enzyme demonstrated an ionic interaction with F-actin in the absence of PEG. These results are in agreement with counter-current distribution studies but not with affinity chromatographic or cosedimentation studies carried out by other researchers (18,19,22). The addition of PEG enhanced the pelleting, which was dependent on ionic strength, of enolase in samples prepared with myogen but not in samples containing purified enzyme. Additionally, the pelleting of enolase in samples containing myogen was significantly greater than in samples containing purified enzyme in the presence of PEG.



These results suggest that PEG specifically enhanced an ionic interaction between enolase and one or more of the components of myogen and/or F-actin. Since pelleting in samples containing myogen was greater than pelleting in samples containing purified enzyme in the absence of F-actin, enolase may have participated in a 'piggy-back' type interaction.

### GPI

GPI demonstrated a specific ionic interaction with F-actin that was enhanced by the presence of PEG which agrees with the results of the affinity chromatography studies of Bronstein and Knull (19) and with the cosedimentation studies of Clarke and Masters (24). PEG also enhanced an interaction between GPI and the components of myogen, which was especially evident in the absence of F-actin. Therefore, the pelleting of GPI in the presence of F-actin in samples containing myogen cannot solely be attributed to an interaction with F-actin, but probably reflects both interactions with F-actin and with the components of myogen. However, there was no difference in the pelleting of GPI when comparing samples containing purified enzyme and those prepared with myogen. This does not rule out 'piggy-backing' interactions but does demonstrate that the presence of both F-actin and the components of myogen did not increase the total number of apparent interactions of

GPI. The results suggest that while the components of myogen provide binding sites, they also may occupy binding sites that were available to GPI on F-actin in the absence of the myogen components.

#### Aldolase and GAPDH

The interaction of aldolase with F-actin has been extensively studied. As mentioned in the Introduction, interactions between aldolase and F-actin have been demonstrated by effects on enzyme activity, histochemical colocalization, counter-current distribution, cosedimentation, affinity chromatography, ease of extraction, cosedimentation, and electron microscopy (13,16,18,19,22,24,25,27,29-35,62). Aldolase, in samples containing the purified enzyme, demonstrated a specific ionic interaction with F-actin in the absence of PEG. In samples containing the myogen preparation, aldolase demonstrated an ionic interaction with F-actin in either the presence or absence of PEG. In the absence of F-actin, PEG apparently enhanced ionic interactions of aldolase with the components of myogen. These interactions are apparently responsible for the greater pelleting of aldolase in samples containing myogen, F-actin, and PEG in the absence of KCl when compared to samples containing purified enzyme. However, in the presence of F-actin, PEG, and 0.30 M KCl, samples containing purified aldolase sedimented more than samples

containing myogen. Since hydrophobic interactions would be enhanced with increasing ionic strength, the results suggest that some sort of hydrophobic interaction occurs between aldolase and F-actin at 0.30 M KCl in the presence of PEG. The difference in the pelleting of aldolase in samples containing the purified and myogen enzymes in the presence of F-actin and absence of PEG and KCl suggests that aldolase may compete with some components of myogen for sites of interaction with F-actin.

Various methods have demonstrated an interaction between GAPDH and F-actin including effects on enzyme activity, counter-current distribution, affinity chromatography, and cosedimentation (16,18,19,22-26). GAPDH, in samples containing purified enzyme, demonstrated an ionic interaction with F-actin that was enhanced by PEG. This interaction was specific for F-actin in the presence or absence of both KCl and PEG. GAPDH also demonstrated an apparently ionic interaction with the components of myogen which was enhanced by PEG. The amount of pelleting of GAPDH in samples containing F-actin and myogen was not different from samples containing myogen in the absence of F-actin. Therefore, no interpretation can be made about the type of interactions taking place, such as 'piggy-backing'. The lower pelleting in samples containing myogen when compared to samples containing purified enzyme in the presence of F-actin and the absence of PEG and KCl suggests that GAPDH is

competing with one or more components of myogen for binding sites.

#### PK and LDH

PK demonstrated an ionic interaction with F-actin which was specific for F-actin in the absence of KCl and was enhanced by 11 percent PEG. Interactions between PK and F-actin have also been demonstrated by counter-current distribution, affinity chromatography, and cosedimentation (18,19,22,24,25). An ionic interaction between PK and the components of myogen which was enhanced by 11 percent PEG also was evident. In the presence of 14 percent PEG, an ionic interaction between the PK present in myogen and F-actin is apparent. However, since there are no differences demonstrated between samples prepared with purified enzyme and samples prepared with myogen at 14 percent PEG, the type of interaction taking place, whether directly with F-actin, or 'piggy-backing' cannot be determined.

LDH demonstrated an ionic interaction with F-actin which was enhanced by the presence of 11 percent PEG and was specific for F-actin in the absence of PEG and KCl. An interaction between LDH and F-actin has been demonstrated by other researches using the effect of the interaction on enzyme activity, affinity chromatography, and cosedimentation (16,18,19,22,24,25). LDH demonstrated an ionic interaction with the components of myogen which was

only evident in the presence of either 11 or 14 percent PEG. Although no difference between the pelleting of LDH present in samples containing myogen when comparing the presence of 11 percent PEG to the presence of F-actin and 11 percent PEG, a difference of the presence of 14 percent PEG with the presence of F-actin and 14 percent PEG is evident at 0.15 and 0.30 M KCl. However, these differences do not correspond with the difference between samples prepared with purified enzyme and those prepared with myogen which is only evident at 0 M KCl. Once again, the type of interaction taking place whether directly with F-actin or 'piggy-backing' is obscured.

#### The Pelleting of Purified Glycolytic Enzymes in the Presence of Other Purified Glycolytic Enzymes and PEG

The pelleting of enzymes in myogen preparations in the absence of F-actin suggests that interactions may occur among the glycolytic enzymes. The results from pelleting of specific enzyme combinations suggest that PFK interacts with GAPDH, aldolase, GPI, and enolase. This is in agreement with the results of Gerlach and Hofer (42) who not only observed interactions of PFK with these enzymes but also with PK and LDH. However, no evidence of an interaction between PFK and either aldolase or GPI was found in kinetic studies by Ovadi et al. (43). Aldolase apparently interacted with PK, LDH, and GAPDH. However, aldolase did not induce a greater amount of pelleting of

GAPDH than did other enzymes. This latter observation could be due to the relatively large amount of GAPDH that pelleted regardless of the combination enzyme, thus preventing interpretation of the data. An interaction between aldolase and GAPDH has been observed by several other researchers (44-47).

#### Units of Enzyme Activity Per Sample

The differences in the amount of enzyme present in the samples could be the cause of differences in results seen when comparing samples containing purified enzyme with those containing myogen due to saturation of binding sites in one preparation but not in the other. For the enzymes GAPDH, GPI, and TPI, more units of purified enzyme than myogen were present in each sample. Therefore, the greater percentage of myogen than purified enzyme found in the pellet fraction for GAPDH and GPI, in some instances, may be explained as saturation of the available binding sites and thus a lower percent of the total activity in the pellet fraction for samples prepared with purified enzyme compared to samples containing myogen. Samples with aldolase, LDH, PK, enolase, and PGM contained more units of enzyme activity per sample when prepared with myogen than those prepared with purified enzyme. Therefore, assuming an equal and finite number of binding sites per sample, the results for these enzymes should demonstrate a lower

percentage of pelleting in samples prepared with myogen than in those prepared with purified enzyme. However, for LDH, PK, enolase, and PGM the amount of enzyme pelleting was either nearly equal for the two types of samples or was greater in the samples containing myogen, indicating interactions of these enzymes with myogen proteins and the possibility of 'piggy-back' interactions. The larger amount of pelleting in samples containing purified aldolase than aldolase in myogen preparation observed under certain conditions may be attributed to the saturation of binding sites in samples prepared with myogen.

#### Relationship of the Observed Interactions to the Microtrabecular Lattice

Interactions between glycolytic enzymes and F-actin, among glycolytic enzymes, and possibly between glycolytic enzymes and unidentified components of myogen may take place within the microtrabecular lattice. Associations with F-actin suggest that actin filaments may provide a structural base upon which the microtrabecular lattice is built and may contribute to the organization of the sections of the microtrabecular lattice located near the actin filaments. As depicted in Figure 14, the trabeculae, composed of glycolytic enzymes and other cytosolic but not cytoskeletal proteins, may radiate away from anchoring sites such as actin filaments, and permeate throughout the cytoplasm. This latter view differs from Clegg's model

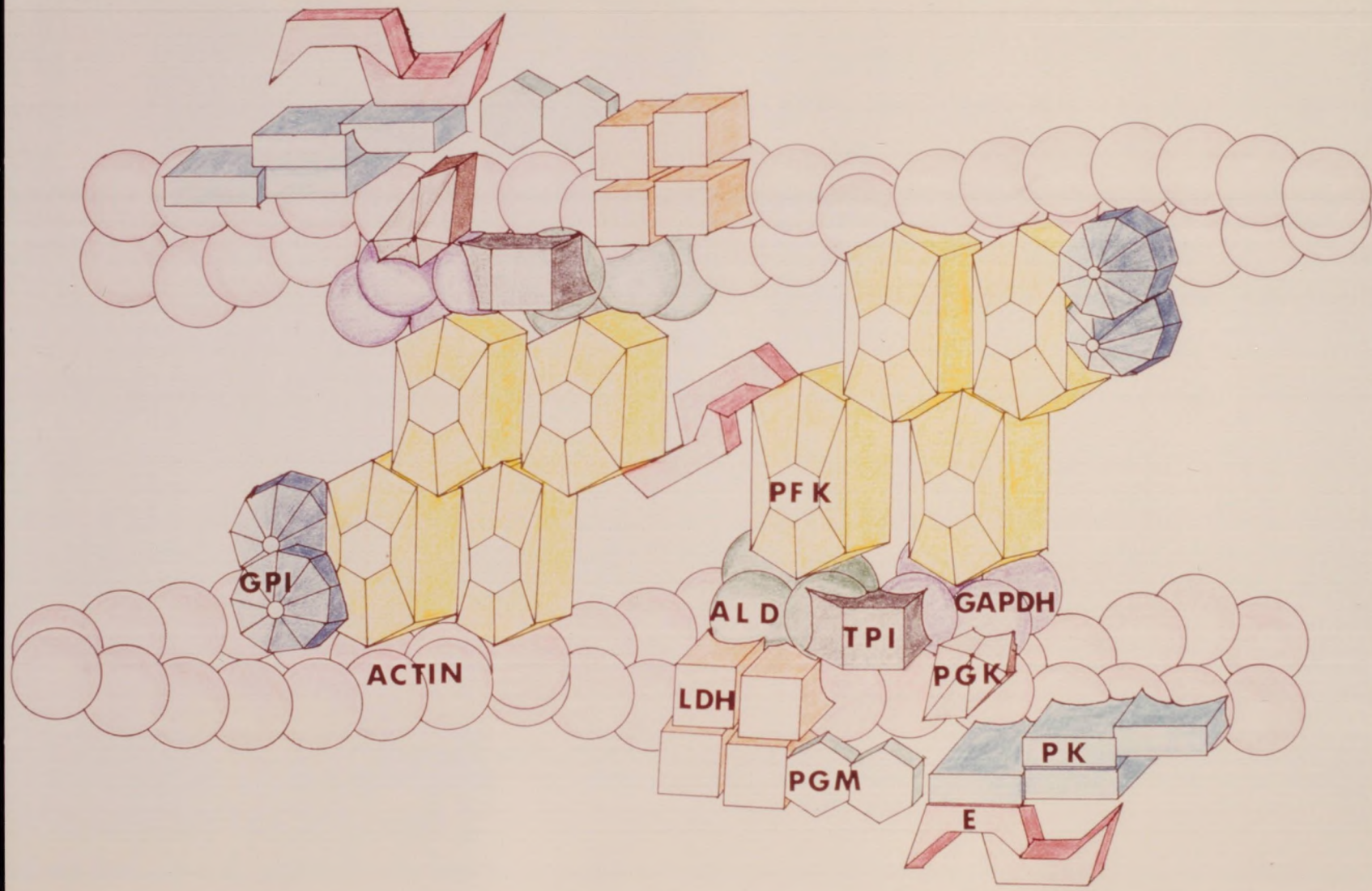



(shown in Figure 2) in which the trabeculae are composed of actin filaments with glycolytic enzymes bound along the filaments. Figure 14 does not take into consideration the relative concentrations of the enzymes or the percentages of the enzymes that would be soluble versus bound. Molar concentrations of the glycolytic enzymes present in skeletal muscle have been calculated by Clarke and Masters (89). From the molar concentrations, the molar ratios are calculated to be: 0.4 GPI: 1 PGM or PK: 2 LDH or enolase: 3 PGK, aldolase, or TPI: 6 GAPDH.

The sensitivity of the interactions demonstrated herein to the concentration of KCl suggests that the protein interactions necessary for the existence of the microtrabecular lattice may be manipulated by changes in intracellular ionic strength. Changes in intracellular concentrations of specific ions, metabolites, or other effectors also are possible mediators of changes in the microtrabecular structure which may be necessary for cellular adaptation to changes in the extracellular environment. Such structural changes could be advantageous to the cell by allowing control of the overall rate of metabolism due to changes in efficiency of metabolic channeling via interactions between enzymes which catalyze sequential reactions.

Summary of the Discussion and Future Areas of Research

Interactions of glycolytic enzymes with F-actin and with other glycolytic enzymes were studied in the presence of PEG, which acted as a crowding agent to more effectively mimic intracellular conditions. Cosedimentation was used as an indication of the interactions studied, which must take place within the structure of the microtrabecular lattice and between the microtrabecular lattice and the cytoskeleton. The results indicate that several interactions may take place and that any one protein may associate with any of several other proteins which are present in the cytoplasm. This extensive network of interacting proteins would allow for rapid control of a sequence of reactions such as glycolysis and would also allow for rapid communication between all parts of the cell. This communication system may be involved in the overall control of metabolism which may change in response to an extracellular effector. This network also allows for compartmentalization of specific proteins responsible for a sequence of events and for local control over the activity of these compartmentalized proteins. Control over the cellular metabolism could easily be achieved by changing intracellular conditions such as availability of substrate or a change in the concentration of an ion. As demonstrated here, changes in ionic strength result in changes in protein interactions, and PEG allowed the detection of these interactions at high

ionic strengths which may reflect the enhancement and stabilization of ionic protein interactions that normally occur in the crowded interior of the cell.

Future research aimed at further definition of the structure and function of the microtrabecular lattice would enhance our understanding of cellular structure and metabolism. Studies of the interactions of the glycolytic enzymes with other cytoskeletal elements, such as microtubules and intermediate filaments, or with proteins associated with membranes, such as receptors or ion channels or pumps, may reveal anchoring sites for the microtrabecular lattice. The effects of metabolites on specific interactions and the effects that binding may have on enzyme activity may give insights to intracellular metabolic controls.

The binding of a substrate by an enzyme may lead to an indirect interaction with another enzyme via a 'substrate bridge' (as presented in the Introduction for an interaction between GAPDH and PGK) which not only has structural implications but also indicates that channeling could occur. 'Substrate bridges' could also be involved in other interactions, especially for enzymes that did not demonstrate much binding in the present study such as TPI, PGM, and enolase. The binding of a substrate by an enzyme may induce a conformational change which may result in the exposure or concealment of a domain responsible for the

association with another protein. Similar effects may be produced by allosteric effectors or phosphorylation of the protein. Therefore, the effects that substrates, allosteric effectors, and phosphorylation have on specific interaction also should be studied.

These interactions and metabolic effects may vary with the type of cell being studied due to the expression of different genes and the resultant production of different isomers of the proteins under study. Therefore, studies comparing the interactions that occur between the proteins obtained from different tissues, along with analyses of the structural domains involved, would further our knowledge of what protein structures are involved in interactions, what determines the extent or strength of the interaction.

Comparisons of the domains involved in the binding of different proteins to a common protein, and whether or not they compete for a common binding domain on the common protein, as suggested by apparent competition of some enzymes in this study for a common binding site on F-actin, also may give insights as to what types of interactions occur and what protein structures are involved. The specific protein domains involved in a specific interaction also could be determined by studying the interaction following partial proteolysis (as done for aldolase and GAPDH (35,36)), application of monoclonal antibodies specific for certain protein domains, and chemical

modification. Additionally, the type of interaction occurring may be characterized by studying the effects of PEG, salt, glycerol, or 2-methyl-2,4-pentanediol on the interaction. PEG should enhance the interaction, salt should reduce an ionic interaction, glycerol should promote hydrophobic interactions, and 2-methyl-2,4-pentanediol should promote ionic interactions (73).

Finally, the effects that extracellular effectors have on the microtrabecular lattice could be determined. Treatment of cells with various extracellular effectors followed by electron microscopy, by observing the movement of a labeled macromolecule, or by measuring the rate of release of specific proteins after treatment with Brij 58, as presented in the Introduction, may reveal differences in the structure. If the structure of the microtrabecular lattice is altered in response to extracellular effectors, there must be some point at which the microtrabecular lattice, or that part of it involved in the response, goes through a transition or reorganization period similar to 'melting' and 'refreezing' or at least detachment and reattachment of some proteins. During such a reorganization period, the microtrabecular lattice may either disappear or appear distorted when viewed with electron microscopy. If the reorganization involves 'melting' of some areas, a labeled macromolecule should demonstrate more freedom of movement within the cell during this period. Furthermore,

such solubilization of the component proteins could be followed in cells treated with Brij 58 which should show an increase in the release of the component proteins from the cells.

APPENDICES

## APPENDIX A

### KEY TO ABBREVIATIONS USED IN TEXT

#### Enzymes

Ald or Aldolase	D-fructose-1,6-bisphosphate D-glycer-aldehyde-3-phosphate lyase, EC 4.1.2.13
Enol or Enolase	2-phospho-D-glycerate hydro-lyase, EC 4.2.1.11
Fructose-1,6-bisphosphatase	D-Fructose-1,6-bisphosphate 1-phosphohydrolase, EC 3.1.3.11
GAPDH or Glycer-aldehyde-3-phosphate Dehydrogenase	D-glyceraldehyde-3-phosphate:NAD <sup>+</sup> oxidoreductase (phosphorylating), EC 1.2.1.12
Glycero-phosphate Dehydrogenase	sn-Glycerol-3-phosphate:NAD <sup>+</sup> 2-oxidoreductase, EC 1.1.1.8
GPI or Glucose-6-phosphate Isomerase	D-glucose-6-phosphate ketol-isomerase, EC 5.3.1.9
LDH or Lactate Dehydrogenase	(S)-lactate:NAD <sup>+</sup> oxidoreductase, EC 1.1.1.27
PFK or 6-phospho-fructokinase	ATP:D-fructose-6-phosphate 1-phosphotransferase, EC 2.7.1.11
PGK or Phospho-glycerate Kinase	ATP:3-phospho-D-glycerate 1-phosphotransferase, EC 2.7.2.3
PGM or Phospho-glycerate Mutase	D-phosphoglycerate 2,3-phosphomutase, EC 5.4.2.1
PK or Pyruvate Kinase	ATP:Pyruvate O <sup>2</sup> -phosphotransferase, EC 2.7.1.40
TPI or Triose-phosphate isomerase	D-glyceraldehyde-3-phosphate ketol-isomerase, EC 5.3.1.1

#### Reagents

BSA	Bovine serum albumin
DTT	Dithiothreitol



Hepes	4-(2-hydroxyethyl)-1-piperazine-ethanesulfonic acid
KCl	Potassium chloride
NADH	Nicotinamide adenine dinucleotide, reduced form
NADP	Nicotinamide adenine dinucleotide phosphate
PEG	Polyethylene glycol
Tris	tris(hydroxymethyl)aminomethane

Units

g	gram
g	force of gravity
M	molar
min	minute
ml	milliliter
mM	millimolar
nm	nanometer
RPM	revolutions per minute
S.E.	standard error
$\mu$ g	microgram
$\mu$ l	microliter
$\mu$ mole	micromole
$^{\circ}$ C	degrees Centigrade

## REFERENCES

1. Metzuzals, J. and Izard, C.S. (1969) *J. Cell Biol.* 43, 456-479.
2. Metzuzals, J. (1969) *J. Cell Biol.* 43, 480-505.
3. Yamada, K.M., Spooner, B.S., and Wessells, N.K. (1971) *J. Cell Biol.* 49, 614-635.
4. Wolosewick, J.J. and Porter, K.R. (1976) *Am. J. Anat.* 147, 303-324.
5. Wolosewick, J.J. and Porter, K.R. (1979) *J. Cell Biol.* 82, 114-139.
6. Wolosewick, J.J. and Porter, K.R. (1977) *J. Cell Biol.* 75, 275a.
7. Porter, K.R. (1984) *J. Cell Biol.* 99, 3s-12s.
8. Schliwa, M., van Blerkom, J., and Porter, K.R. (1981) *Proc. Natl. Acad. Sci.* 78, 4329-4333.
9. Knull, H.R. (1985) *J. Neurochem.* 45, 1433-1440.
10. Amberson, W.R., Roisen, F.J., and Bauer, A.C. (1965) *J. Cell. and Comp. Physiol.* 66, 71-90.
11. Pette, D. and Brandau, H. (1962) *Biochem. Biophys. Res. Comm.* 9, 367-370.
12. Fahimi, H.D. and Amarasingham, C.R. (1964) *J. Cell Biol.* 22, 29-48.
13. Sigel, P. and Pette, D. (1969) *F. Histochem. Cytochem.* 17, 225-237.
14. Dolken, G., Leisner, E., and Pette, D. (1975) *Histochemistry* 43, 113-121.
15. Clegg, J.S. (1984) *J. Cell Biol.* 99, 167s-171s.
16. Poglazov, B.F. and Lovanova, N.B. (1986) *Adv. Enzyme Regul.* 25, 297-305.
17. Karkhoff-Schweizer, R.R. (1988) PhD dissertation, University of North Dakota, Grand Forks, ND.
18. Westrin, H. and Backman, L. (1983) *Eur. J. Biochem.* 136, 407-411.
19. Bronstein, W.W. and Knull, H.R. (1981) *Can. J. Biochem.* 59, 494-499.

20. Knull, H.R., Bronstein, W.W., DesJardins, P., and Niehaus, W.G. Jr. (1980) *J. Neurochem.* 34, 222-225.
21. Arnold, H. and Pette, D. (1968) *Eur. J. Biochem.* 6, 163-171.
22. Arnold, H., Henning, R., and Pette, D. (1971) *Eur. J. Biochem.* 22, 121-126.
23. Dagher, S. and Hulton, H.O. (1975) *Eur. J. Biochem.* 55, 185-192.
24. Clarke, F.M. and Masters, C.J. (1975) *Biochim. Biophys. Acta* 381, 37-46.
25. Clarke, F.M. and Morton, D.J. (1982) *Biochem. Biophys. Res. Comm.* 109, 388-393.
26. Reid, S. and Masters, C. (1986) *Mech. Aging Dev.* 35, 209-219.
27. Reid, S. and Masters, C. (1985) *Mech. Aging Dev.* 30, 299-317.
28. Reid, S. and Masters, C. (1985) *Mech. Aging Dev.* 31, 69-87.
29. Arnold, H., Nolte, J., and Pette, D. (1969) *J. Histochem. Cytochem.* 17, 314-320.
30. Clarke, F.M. and Masters, C.J. (1972) *Arch. Biochem. Biophys.* 153, 258-265.
31. Morton, D.J., Clarke, F.M., and Masters, C.J. (1977) *J. Cell Biol.* 74, 1016-1023.
32. Harris, S.J. and Winzor, D.J. (1985) *Arch. Biochem. Biophys.* 243, 598-604.
33. Kuter, M.R., Masters, C.J., and Winzor, D.J. (1983) *Arch. Biochem. Biophys.* 225, 384-389.
34. Humphreys, L., Reid, S., and Masters, C. (1986) *Int. J. Biochem.* 18, 7-13.
35. Harris, S.J. and Winzor, D.J. (1987) *Biochim. Biophys. Acta* 911, 121-126.
36. Humphreys, L., Reid, S., and Masters, C. (1986) *Int. J. Biochem.* 18, 445-451.

37. Choate, G.L., Lan, L., and Mansour, T.E. (1985) *J. Biol. Chem.* 260, 4815-4822.
38. Kuo, H.J., Malencik, D.A., Liou, R.S., and Anderson, S.R. (1986) *Biochemistry* 25, 1278-1286.
39. Luther, M.A. and Lee, J.C. (1986) *J. Biol. Chem.* 261, 1753-1759.
40. de Duve, C. (1972) in Structure and Function of Oxidation Reduction Enzymes (Keson, A.A. and Ehreberg, A. eds) pp. 715-728, Pergamon Press, Oxford.
41. Kurganov, B.I., Sugrobova, N.P., and Mil'man, L.S. (1985) *J. theor. Biol.* 116, 509-526.
42. Gerlach, G. and Hofer, H.W. (1986) *Biochim. Biophys. Acta* 881, 398-404.
43. Ovadi, J., Aragon, J.J., and Sols, A. (1986) *Biochem. Biophys. Res. Comm.* 135, 852-856.
44. Kwon, T.W., and Olcott, H.S. (1965) *Biochem. Biophys. Res. Comm.* 19, 300-305.
45. Ovadi, J. and Keleti, T. (1978) *Eur. J. Biochem.* 85, 157-161.
46. Ovadi, J., Salerno, C., Keleti, T., and Fasella, P. (1978) *Eur. J. Biochem.* 90, 499-503.
47. Patthy, L. and Vas, M. (1978) *Nature* 276, 94-95.
48. Salerno, C. and Ovadi, J. (1982) *FEBS Letts.* 138, 270-272.
49. Orosz, F., Nuridsany, M., and Ovadi, J. (1986) *J. Biochem. Biophys. Methods* 13, 325-332.
50. Orosz, F. and Ovadi, J. (1986) *Eur. J. Biochem.* 160, 615-619.
51. Vas, M. and Batke, J. (1981) *Biochim. Biophys. Acta* 660, 193-198.
52. Weber, J.P. and Bernhard, S.A. (1982) *Biochemistry* 21, 4189-4194.
53. Ashmarina, L.I., Muronetz, V.I., and Nagradova, N.K. (1985) *Eur. J. Biochem.* 149, 67-72.

54. Ashmarina, L.I., Muronetz, V.I., and Nagradova, N.K. (1984) *Biochem. Int.* 9, 511-521.
55. Rodriguez-Fernandez, J.L., Frias, I., Perez, J.A., and Siverio, J.M. (1987) *Biochem. Int.* 14, 539-545.
56. Clarke, F.M. and Masters, C.J. (1974) *Biochim. Biophys. Acta* 358, 193-207.
57. Clarke, F., Stephan, P., Morton, D., and Weidemann, J. (1983) in Actin: Structure and Function in Muscle and non-muscle cells (Barden, J. and Dos Remedios, C., eds.) pp. 249-257, Academic Press, Australia.
58. Stephan, P., Clarke, F., and Morton, D. (1986) *Biochim. Biophys. Acta* 873, 127-135.
59. Welch, G.R. (1977) *Prog. Biophys. molec. Biol.* 32, 103-191.
60. Ottaway, J.H. and Mowbray, J. (1977) *Curr. Top. Cell. Regul.* 12, 107-208.
61. Clarke, F., Stephan, P., Morton, D., and Weidemann, J. (1985) in CRC Regulation of Carbohydrate Metabolism (Beitner, R. ed) Vol. 2, pp. 1-31, CRC Press, Boca Raton.
62. Srere, P.A. (1987) *Ann. Rev. Biochem.* 56, 89-124.
63. Srivastava, D.K. and Bernhard, S.A. (1986) *Curr. Top. Cell. Regul.* 28, 1-68.
64. Harper, H.A. (1969) in Review of Physiological Chemistry p. 244 Lange Medical Publications, Los Altos, CA.
65. Clegg, J.S. (1984) *Am. J. Physiol.* 246, R133-R151.
66. Lechene, C. (1985) *Biol. Cell* 55, 177-180.
67. Gershon, N.D., Porter, K.R., and Trus, B.L. (1982) *J. Cell Biol.* 95, 406a.
68. Fulton, A.B. (1982) *Cell* 30, 345-347.
69. Clegg, J.S. (1981) *Cold Spring Harbor Symp.* 46, 23-37.
70. Minton, A. (1983) *Mol. Cell. Biochem.* 55, 119-140.
71. Minton, A.P. (1981) *Biopolymers* 20, 2093-2120.

72. Nichol, L.W., Ogston, A.G., and Wills, P.R. (1981) FEBS Letts. 126, 18-20.
73. Arakawa, R. and Timasheff, S.N. (1985) Biochemistry 24, 6756-6762.
74. Robinson, J.B. Jr. and Srere, P.A. (1985) Biochem. Med. 33, 149-157.
75. Halper, L.A. and Srere, P.A. (1977) Arch. Biochem. Biophys. 184, 529-534.
76. Sumegi, B., Bilbert, H.F., and Srere, P.A. (1985) J. Biol. Chem. 260, 188-190.
77. Sumegi, B. and Alkonyi, I. (1983) Biochim. Biophys. Acta 749, 163-171.
78. Porpaczy, Z., Sumegi, B., and Alkonyi, I. (1983) Biochim. Biophys. Acta 749, 172-179.
79. Medina, R., Aragon, J.J., and Sols, A. (1985) FEBS Letts. 180, 77-80.
80. Katz, A.M. (1971) in Methods in Pharmacology (Schwartz, A., ed.) pp. 389-430, Plenum Press, New York.
81. Bradford, M.M. (1976) Anal. Biochem. 72, 248-254.
82. Neal, M.W. and Florini, J.R. (1973) Anal. Biochem. 55, 328-330.
83. Bergmeyer, H.V., Gawehn, K., and Grassel, M. (1974) Methods in Enzymatic Analysis, 2nd Ed, pp. 430-515, Academic Press, Inc., New York.
84. Tamir, H., Kaufman, H., and Rapport, M.M. (1972) J. Neurochem. 19, 1759-1768.
85. Clarke, F.M., Shaw, F.D., and Morton, D.J. (1980) Biochem. J. 186, 105-109.
86. Rohlf, F.J. (1986) Biom. A Package of STATISTICAL PROGRAMS to accompany the text BIOMETRY. Applied Biostatistics, Inc. Setauket, N.Y.
87. Sokal, R.R., and Rohlf, R.J. (1981) Biometry. The Principles and Practice of Statistics in Biological Research. pp. 242-262, W.H. Freeman and Co., San Francisco.