



University of North Dakota  
UND Scholarly Commons

---

Undergraduate Theses and Senior Projects

Theses, Dissertations, and Senior Projects

---

2011

# Investigation of In-Situ Stresses in Rocks via Acoustic Emission and the Kaiser Effect.

Derrick J. Blanksma

Follow this and additional works at: <https://commons.und.edu/senior-projects>

---

## Recommended Citation

Blanksma, Derrick J., "Investigation of In-Situ Stresses in Rocks via Acoustic Emission and the Kaiser Effect." (2011). *Undergraduate Theses and Senior Projects*. 107.

<https://commons.und.edu/senior-projects/107>

This Senior Project is brought to you for free and open access by the Theses, Dissertations, and Senior Projects at UND Scholarly Commons. It has been accepted for inclusion in Undergraduate Theses and Senior Projects by an authorized administrator of UND Scholarly Commons. For more information, please contact [zeineb.yousif@library.und.edu](mailto:zeineb.yousif@library.und.edu).

GEOLOGICAL ENGINEERING DESIGN 485

*Investigation of In-Situ Stresses in Rocks  
via Acoustic Emission and the Kaiser  
Effect*

**Derrick Jay Blanksma**

**Spring 2011**

A Geological Engineering Senior Design proposal submitted to the faculty of the University of North Dakota in partial fulfillment of the requirements for the degree of Bachelor of Science in Geological Engineering

## **Acknowledgements**

The author would like to thank the following for their support:

Prof. Zheng-Wen “Zane” Zeng and the Petroleum Engineering Laboratory staff for their guidance and support.

As well as,

US DOE through contract DE-FC26-08NT0005643 (Bakken Geomechanics)

North Dakota Industry Commission together with five industrial sponsors (Denbury Resources Inc., Hess Corporation, Marathon Oil Company, St. Mary Land & Exploration Company, and Whiting Petroleum Corporation) under contract NDIC-G015-031

North Dakota Department of Commerce through UND’s Petroleum Research, Education and Entrepreneurship Center of Excellence (PREEC).

## Table of Contents

List of Figures.....	3
List of Tables and Graphs .....	4
Executive Summary .....	5
1. Introduction .....	6
2. Problem Definition .....	6
3. Theory .....	7
3.1 Empirical Evidence .....	7
3.2 Physical Models for the Kaiser Effect.....	11
4. Preliminary Analysis .....	12
4.1 Design Constraints.....	12
4.2 Software .....	14
4.3 Preliminary Design Options.....	15
4.4 Selected Design .....	16
4.5 Procedure .....	19
5. Work Plan.....	26
5.1 Cost Estimates .....	26
5.2 Schedule for the Design Process .....	27
6. Data and Analysis.....	28
Conclusion .....	31
Appendices .....	32
Appendix A .....	32
Appendix B .....	41
Appendix C.....	46
References .....	47

## List of Figures

Figure 1.	Two loading cycles showing AE counts versus stress.	9
Figure 2.	A graph of the Cumulative AE hits versus Stress for two loading cycles subject to uniaxial compression.	10
Figure 3.	Inflection in the Cumulative AE hits versus Stress graph indicates the previous maximum stress state	10
Figure 4.	AE hit rate versus stress reveals the Kaiser point at the bifurcation of the two different loading cycles	10
Figure 5.	Microcrack model for Acoustic Emission	11
Figure 6.	Rock sample showing direction of vertical stress and attachment of ART's (Acoustic Receiving Transducers)	15
Figure 7.	A close-up picture of the Uniaxial Loading Method	16
Figure 8.	A layout of the 816 Rock Test System (MTS)	17
Figure 9.	A picture of the Preamplifier and Analog to Digital Conversion System	18

## **List of Tables and Graphs**

Table 1.	A list of physical properties of Hinckley Sandstone	19
Table 2.	Cost Estimate Sheet	26
Chart 1.	Schedule for the design process	28
Graph 1.	Cumulative AE versus Stress for 126 acoustic events	29
Graph 2.	Cumulative AE versus Stress for 1800+ acoustic events	30

## **Executive Summary**

This paper is a proposal for designing the Kaiser In-Situ Stress (KISS) System. The KISS System's goal is to determine in-situ stresses in rock formations and other subsurface rocks by means of compression-induced Acoustic Emission (AE) and the Kaiser effect. The KISS System is a non-destructive method of in-situ stress determination and has received much attention in the past. To fully understand AE, the Kaiser Effect and how it relates to stress determination this paper will present the necessary theoretical background, past experimentation and results from the authors own experimentation to investigate the plausibility of AE and the Kaiser Effect for in-situ stress determination. The final goal of the design is to investigate the uniaxial compression induced AE and the Kaiser Effect in rock to determine the fundamental process of the Kaiser Effect. Once confirmation of the Kaiser Effect from the uniaxial compression method is obtained, based on experimentation, more sophisticated experimentation with triaxial compression-induced AE and the Kaiser Effect can be analyzed.

Besides only proposing the KISS System as a theoretical design this paper also presents results from an initial design/prototype KISS System. In order to find out the plausibility of using AE and the Kaiser Effect for in-situ stress determination, experimentation had to be conducted using fundamental processes. Theoretical work on AE and the Kaiser effect has been investigated extensively and the only way to determine scientific plausibility is by empirical observation and analysis. The process investigates uniaxial compression induced AE to determine the presence of the Kaiser effect. By actually performing the experiments that quantify physical phenomena comparisons can be made to see if uniaxial compression induced AE can determine in-situ stresses and be developed further to determine true states of in-situ stress.

## **1. Introduction**

Drilling for oil, creating underground and open pit mines, and building earthen foundations all require a thorough understanding of rock mechanics. In order to effectively and economically drill, dig, blast, haul etc... sophisticated rock analysis techniques are required. In industry there are numerous techniques for measuring rock properties both on site and in the lab. However, these techniques may be inaccurate expensive and even dangerous. Rock analysis by means of induced AE and the Kaiser Effect may offer an alternative, inexpensive and non-intrusive method to determine rock properties; information that is essential to a wide variety of rock engineering disciplines.

## **2. Problem Definition**

Current methods for determining rock in-situ stresses used today fall into two categories:

- 1) Destructive Methods - Measurement methods that disturb the in-situ rock conditions, i.e. inducing strain, deformations or crack openings.
- 2) Non-Destructive Methods - Methods that are based on observation of the rock behavior without major influence on the rock.

The proposed plan will focus on Category 2 by developing a method to determine in-situ stresses in rock that is inexpensive, non-evasive and relatively accurate, based on the fundamental idea of induced acoustic emission.

The plan contains three stages:

- 1) Development of the Kaiser In-situ Stress (KISS) System
- 2) Testing and Improving
- 3) Determination of In-situ stresses



In the first stage the goal is to develop the system based on the theoretical framework of acoustic emission and the Kaiser effect. This stage also includes hardware set up and software design. Another goal in this step is to become familiar with coding the data acquisition system for the KISS System. National Instruments *LabVIEW* will be utilized for data acquisition and data analysis. Since substantial knowledge is required to use *LabVIEW*, designing the data acquisition code offers the opportunity to learn and use a powerful program. In addition, knowing how to code programs using different software is a vital part of all engineering disciplines.

Once the in-situ stresses are experimentally obtained by the KISS System, stress transformation equations will be implemented to determine the principle stress tensor. The stress tensor contains the magnitude of the principal stresses and well as the direction cosines for each stress.

The second stage involves all the testing and calibration of the hardware and software. Different rock samples that represent different oil containing formations will be analyzed to compare one against the other. Because the system relies on analog to digital processing, large amounts of data will need to be stripped down to reveal the physical properties that are useful to this design.

The third stage will focus on using the KISS System as if it was intended to produce results for a paying customer. After the development and testing of the KISS System is accomplished, the third stage focuses on real-world engineering scenarios and it will investigate whether or not the KISS System can produce informative results.

## **3. Theory**

### **3.1 Empirical Evidence**

The Kaiser effect is a physical phenomenon prevalent in many materials as wells as rocks. The theoretical foundation of the Kaiser Effect can be demonstrated by many different physical

phenomena including electromagnetic waves, seismic waves and important to this study, induced acoustic waves. AE (acoustic waves) is a property of wave mechanics and is the propagation of a lateral compression wave through a medium that is produced by an energetic event such as cracking or sudden deformation. The energy of the wave can range greatly. For example, large scale waves travelling through a rock mass are the source of what is commonly known as earthquakes. However, small scale waves are also produced by small strain. These small waves are nowhere near the magnitude of an earthquake, but the idea is logical that some induced AE waves represent “miniature” earthquakes travelling through a rock mass.

Depending on the rate of change in the volume of a rock mass relative to its original volume, i.e. strain rate, energy may be transformed into a pressure wave travelling through the rock mass if cracking occurs. The propagating wave is identified as AE and it directly indicates an amount of damage in a rock specimen from the formation of a crack.

The Kaiser effect can be produced empirically numerous ways. One method for identifying damage in rock is to count acoustic events and look for any changes in time; changes of the number of AE in time represent an increase or decrease in crack growth. The empirical method that exploits the Kaiser effect takes place in rocks and materials subjected to cyclic loading/unloading. In the simplest case of cyclic, uniaxial loading with the cycles peak stress increasing from cycle to cycle, the acoustic emission is zero or close to the background level as long as the current stress remains below the largest previously reached stress value. As this peak stress value is attained, the AE activity increases dramatically (Lavrov A. , 2003). The change in AE activity at the point of previously applied maximum stress is the Kaiser Effect. A graph in Fig. 1 of AE versus time for two cycles illustrates the concept.

The rate of AE is a function of stress on a rock and most importantly the time the rock has been under stress. Because of this relationship rock *may* have the ability to “remember” the largest previous stress that had once acted upon it. The theory is that the first cycle of compression is actually the in-situ stress state of a rock in the subsurface and by extracting a sample of the rock and reloading can be completed in a lab to determine the previously applied maximum stress. This maximum “memorized” stress is a direct consequence of the Kaiser effect and *may* be determined experimentally. By verifying that the memorized stress is in fact the maximum previously applied stress may allow for determination of the entire in-situ stress regime of the rock.

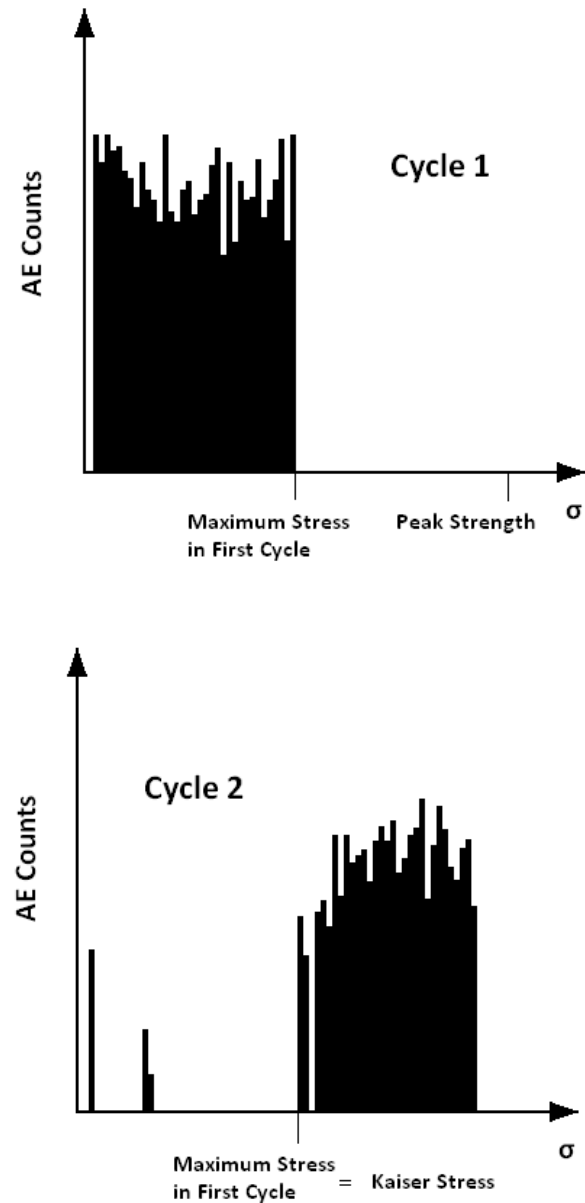

Fig. 1. Two loading cycles showing AE counts versus stress. The absence of AE in cycle 2 indicates the Kaiser Effect.

Determining the “memorized” stress ( $\sigma_m$ ) requires mathematical analysis of the second cycle cumulative AE hits versus stress. The Kaiser effect can be recognized as an inflection point (change in slope) on the graph of cumulative AE versus stress (Lavrov A. , 2003). Fig. 2 and 3 show the location of  $\sigma_m$ . Finding the inflection point can be performed by bilinear regression, or by drawing tangents to the two parts of the curve and searching for their intersection (Lavrov A. , 2003)

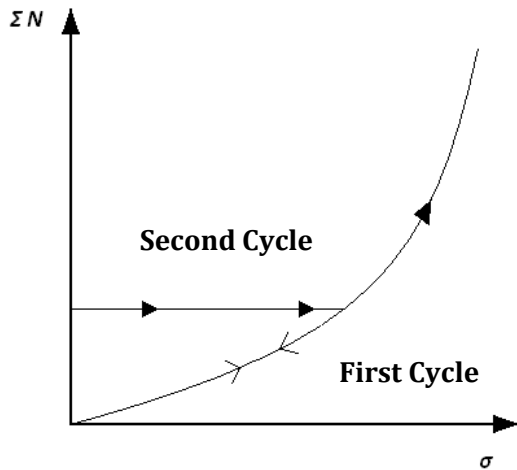

Fig. 2. A graph of the cumulative AE hits ( $\Sigma N$ ) versus stress ( $\sigma$ ) for two loading cycles subject to uniaxial compression

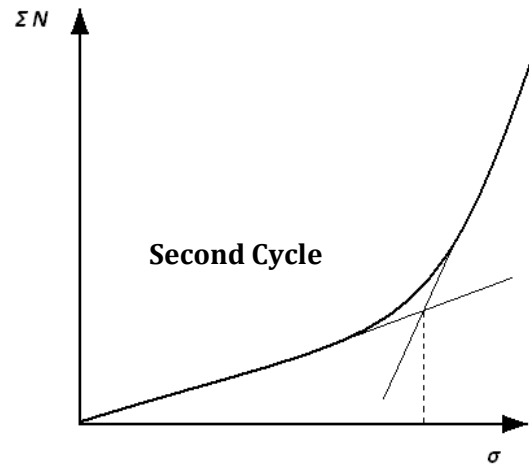

Fig. 3. Inflection in the cumulative AE hits ( $\Sigma N$ ) versus stress ( $\sigma$ ) graph indicates the previous maximum stress state.

Determining the inflection point as the peak memorized stress level requires high resolution equipment and therefore is not always evident when comparing cumulative AE hits versus stress. A technique developed by Yoshikawa and Mogi (1989) can be used by comparing the AE hit *rate* versus stress. Fig. 4 gives a graphical example of this method. This graph shows a better indication of where the Kaiser point is located. The Kaiser point will be indicated by the separation of the two lines corresponding to different loading cycles. In the first cycle AE hit rate increases as stress increases. In the second cycle AE hit rate will be the same as in cycle one. However, once the stress level in cycle two reaches the previous applied stress level in cycle one, AE hit rate will no longer be the same for both cycle one and two. The bifurcation point is the Kaiser point.

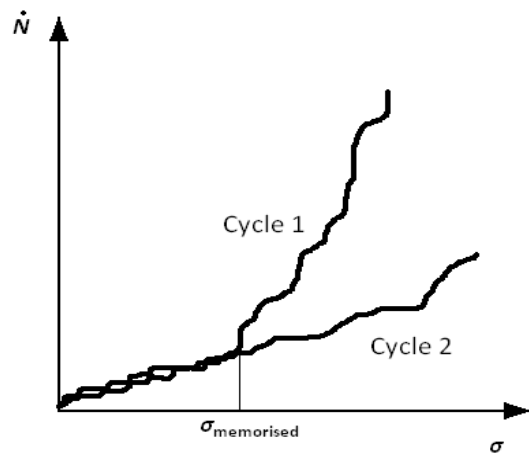

Fig. 4. AE hit rate versus stress ( $\sigma$ ) reveals the Kaiser point at the bifurcation of the two different loading cycles.

### 3.2 Physical Models for the Kaiser Effect

Empirical evidence for the Kaiser effect clearly shows the physical phenomenon and has been extensively investigated prior to the 1980's. However an accepted physical model was not fully developed until much later and still receives changes to this day. The Kaiser effect was first investigated by Joseph Kaiser in the early 1950's. His initial experiments were conducted on metals, woods and sandstones (Kaiser, 1953). Since the work of Joseph Kaiser many physical models have been suggested to explain the Kaiser effect.

For practical purposes the physical model that best explains AE and the Kaiser effect is analogous to the mechanics of an earthquake. During an earthquake deformation of crustal material occurs rapidly and releases energy in the form of shearing (S-waves) and compression (P-waves) waves. In small rock mass, on the order of inches and feet, rapid deformation takes place when exposed to a force. The deformation exists in the form of microcracks. The microcracks can be related to earthquakes but

have orders of magnitude less energy. Fig. 5 shows a schematic of the microcrack model.

Many more sophisticated models have been investigated for AE and the Kaiser effect. Stevens and Holcomb (1980) presented a sliding crack model to account for stress memory in rock.

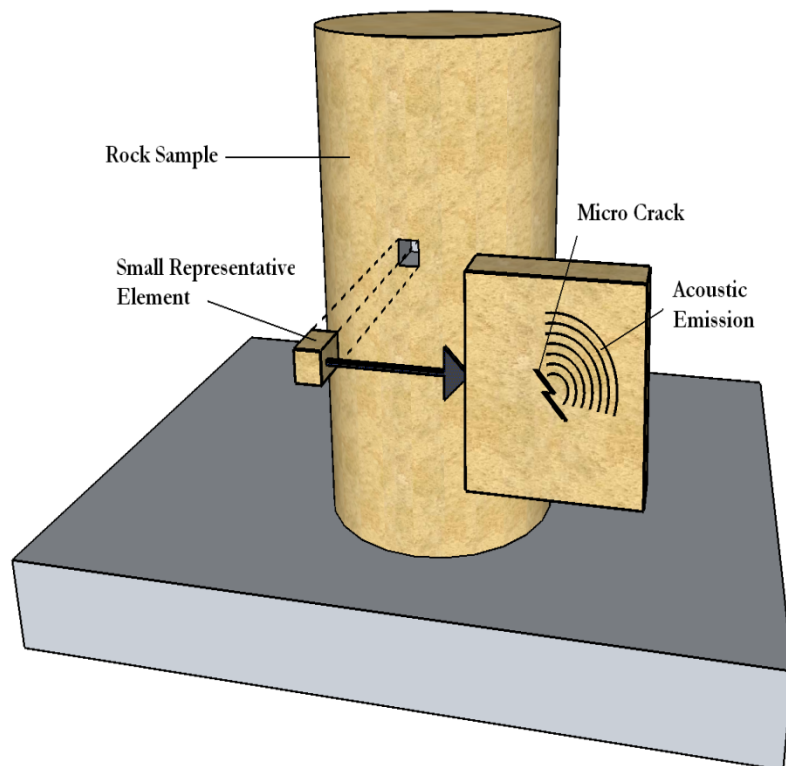

Fig. 5. The microcrack model for AE

Holcomb (1980) also suggested a reversible Griffith crack model to explain the Kaiser effect. Later suggested models by Lavrov (1997) used Fairhurst-Cook wing crack models to interpret the Kaiser effect in uniaxial compression (cycle 2) after true triaxial compression (cycle 1).

## **4. Preliminary Analysis**

### **4.1 Design Constraints**

Obtaining a rock specimen that has been cored from a rock formation can be accomplished directly or indirectly. Direct coring of a rock formation, especially oil containing rock formation is expensive and problematic for the KISS system. For example core from the Bakken Formation in North Dakota is highly valuable and difficult to obtain. Also, obtaining core samples directly disturbs the in-situ stress on the rock and results in damage caused by tensile and shear stresses near the drill bit, thus complicating any Kaiser Effect observation on the sample core (Lavrov A. , 2003). An indirect approach can be considered by using rock with known characteristics that resemble oil containing rocks. Acquiring these rocks is usually inexpensive; however the accuracy of the results depends completely on the similarity of the rock being tested to oil bearing rock. In this study indirect measurement on various rock types will be implemented to ensure the system works properly, if oil containing core can be obtained it will be tested by the KISS System.

Rock type has a profound effect on AE. Most Kaiser effect experiments were performed on brittle rocks because they produce more micro cracks upon compression and thus have a higher AE frequency compared to softer rocks. Results obtained by Filimonov et al. (2002) on rock salt, a very ductile rock, revealed a well pronounced Kaiser effect. Results by Dunning et al. (1989) revealed a clear Kaiser effect on sandstone if the sample was preloaded to about 60% of its peak strength and inclined at an angle to simulate a fault zone.

After obtaining a suitable core sample to test, time is of the essence. Like humans, the ability for a rock to retain its memorized stress history fades with time. Once the rock is removed from the rock mass, AE activity decays exponentially to the point where the Kaiser Effect is indistinguishable (Lavrov , 2003). The reason for the crack “healing” has been an issue that needs further investigation. By receiving a core sample as soon as it is cored will result in a better analysis of the in-situ stresses in the rock formation.

Another issue that must be addressed is the type of testing. When the Kaiser effect was first being investigated most lab measurements involved a uniaxial compression test on the sample. However, Holcomb (1993) showed that it is impossible to determine a rock’s stress history by uniaxial compression when it was stressed in a triaxial environment. The only way a Uniaxial Load Method (ULM) will work effectively in determining stress history is if the primary principle stress ( $\sigma_1$ ) during reloading is parallel by no more than  $10^\circ$  to the primary principle stress during preloading (Lavrov , 2003). This requires an estimate of which direction  $\sigma_1$  acted on the rock sample while it was in-situ. In the case of the KISS System and in most lab methods  $\sigma_1$  is considered to be in the vertical direction, as a result of the overlying rock mass. If obtaining the preloaded  $\sigma_1$  stress direction is accomplished and the sample is reloaded by the ULM, the very best results are only a linear combination of the in-situ stress tensor of the rock in question (Lavrov , 2003).

After determining which method of compression is better suited for the experiment, determining how to conduct the experiment is crucial. During the cyclic loading test it is best to ensure that the preloading cycle does to reach the maximum strength of the rock. The closer the preloading stress to the ultimate strength of the rock, the less pronounced the Kaiser effect is during reloading (Kurita & Fujii, 1979). According to Lavrov, “In order to obtain a well – pronounced Kaiser effect, the preload stress should be in a range from about 30% to about 80% of the ultimate strength (Lavrov, 2003).

Experiments have shown that the longer the duration of loading on soft rocks in the first cycle creates a clearer Kaiser effect in the reloading cycle (Michihiro, Yoshioka, & Hata, 1989). On brittle rocks experiments have shown little influence of the duration of loading on the Kaiser effect (Yoshikawa & Mogi, 1989). However, a study on brittle rocks has found that if the loading rate in the first cycle is fast compared to that of the second cycle, then the Kaiser effect occurred at 67% of the peak stress of the first cycle. When the order was reversed (first cycle slow, second cycle fast) the Kaiser effect occurred at the peak stress of the first cycle. The dependency of the Kaiser Effect on the loading rate has not been determined for soft rocks and plastic rocks (Lavrov, 2001).

The KISS System is intended to provide a more cost effective rock in-situ stress testing method than its predecessors without sacrificing accuracy. For example, in the majority of rock testing methods used today an expensive piece of equipment has to be placed down the borehole into the rock formation and analyzed on site. These methods do work; however, the KISS System eliminates the need to send equipment into the borehole. The KISS System requires only obtaining core samples of the rock formation that can then be brought back to a lab for analysis.

## **4.2 Software**

Software is a crucial component of the KISS System. While many programs exist for other rock testing systems the KISS System is unique in the way that it will need its own data acquisition program. Creating a program for the KISS System will require substantial knowledge about coding. In industry, a practical solution may be to hire a software engineer or computer scientist. However, in an industry that also hinges on technical application and economic practicality, being able to create your own code for projects that require customized data acquisition eliminates the need to hire a software engineer or computer scientist.

All programs in this system have been designed by the author. Proficiency in coding for data acquisition and correlation is necessary to create and understand programs that record reliably.



The software used in the KISS System is National Instruments LabVIEW 8.2. Because of its superior data analysis and ease of coding using G-language, LabVIEW is excellent software for coding customizable programs. The three important programs for the KISS System include; 1 – The data acquisition program that will be used during experimentation, 2 – a waveform analysis program to determine AE and its corresponding times and, 3 – a correlating program to match force data with AE data to construct a cumulative AE versus stress/force graph.

### 4.3 Preliminary Design Options

The KISS system can be designed two ways: The first using the uniaxial load method (ULM), and the second using a triaxial load method. The ULM requires applying a load along the axis of the rock sample in a direction that is no more than 10 degrees different from the in-situ principal stress direction (Lavrov A. , 2003). The method relies on the estimation that the in-situ principal stress is directed along the vertical axis (see Fig.

6) of the rock sample. Upon loading, acoustic transducers will record analog signals of the AE activity and run the signal to a high-speed digitizer. The digital signals will be recorded and analyzed by signal analyzing software. At the same time the uniaxial compression system will also have force transducers to record the stress data along with the corresponding time of each stress level. By comparing the stress values and acoustic emission values with the

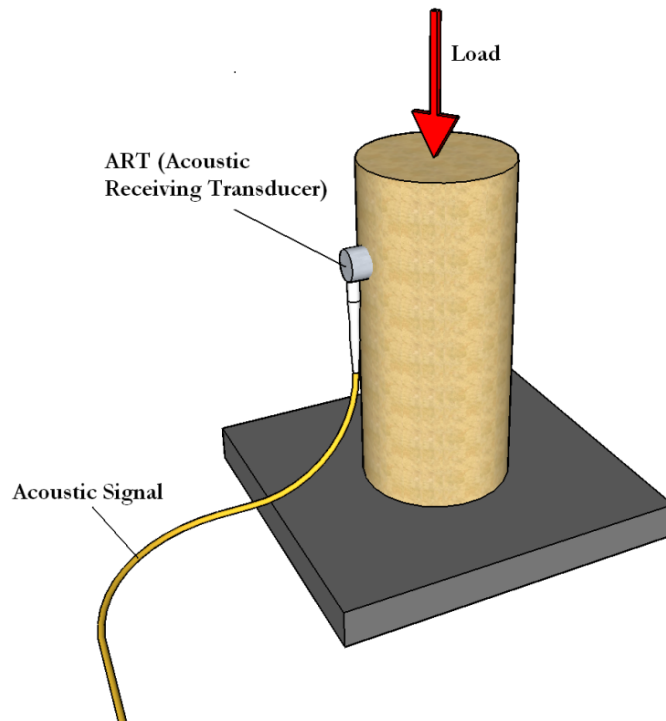

**Fig. 6. Rock sample showing direction of vertical stress and attachment of ART's (Acoustic Receiving Transducers)**

corresponding times, the memorized stress level can be deduced on principles described in the Section 3. However, the limit of finding the memorized stress level for the ULM is only a linear combination and the entire stress tensor can never be achieved using the ULM, as described in Section 4.1.

The triaxial design option includes similar but much more sophisticated waveform analysis software, and very different hardware. A triaxial load method requires a compression machine that can achieve three degrees of pressure. In the case of a triaxial KISS system, axisymmetric ( $\sigma_1 > \sigma_2 = \sigma_3$ ) or true triaxial ( $\sigma_1 > \sigma_2 > \sigma_3$ ) compression is needed to exploit the Kaiser Effect. Operating a triaxial compression machine that can be either axisymmetric or triaxial requires a high degree of operating knowledge and maintenance.

However, finding the complete stress tensor requires a device that can achieve true triaxial compression (Holcomb, 1993).

#### 4.4 Selected Design

The KISS System will use the Uniaxial Loading Method (see Fig. 7). While using a triaxial compression machine is ideal, the fundamental concept of uniaxial compression and the Kaiser Effect needs to be experimentally evaluated before triaxial experimentation can continue. An MTS 816 Rock Mechanics Testing system will provide the uniaxial compression. This rock testing system was chosen because it provides servo-controlled loading for highly stabilized loading rates.

The components of the uniaxial rock testing system include a pump which controls the compression hydraulics, the uniaxial compression machine, two acoustic receiving transducers

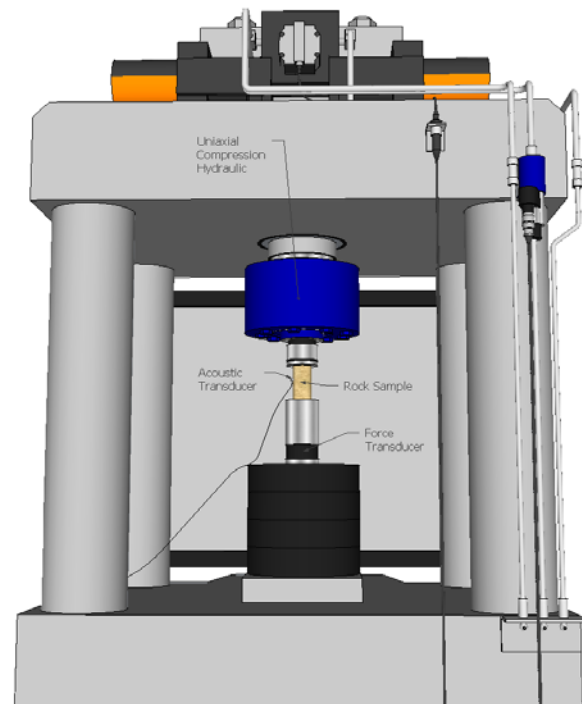
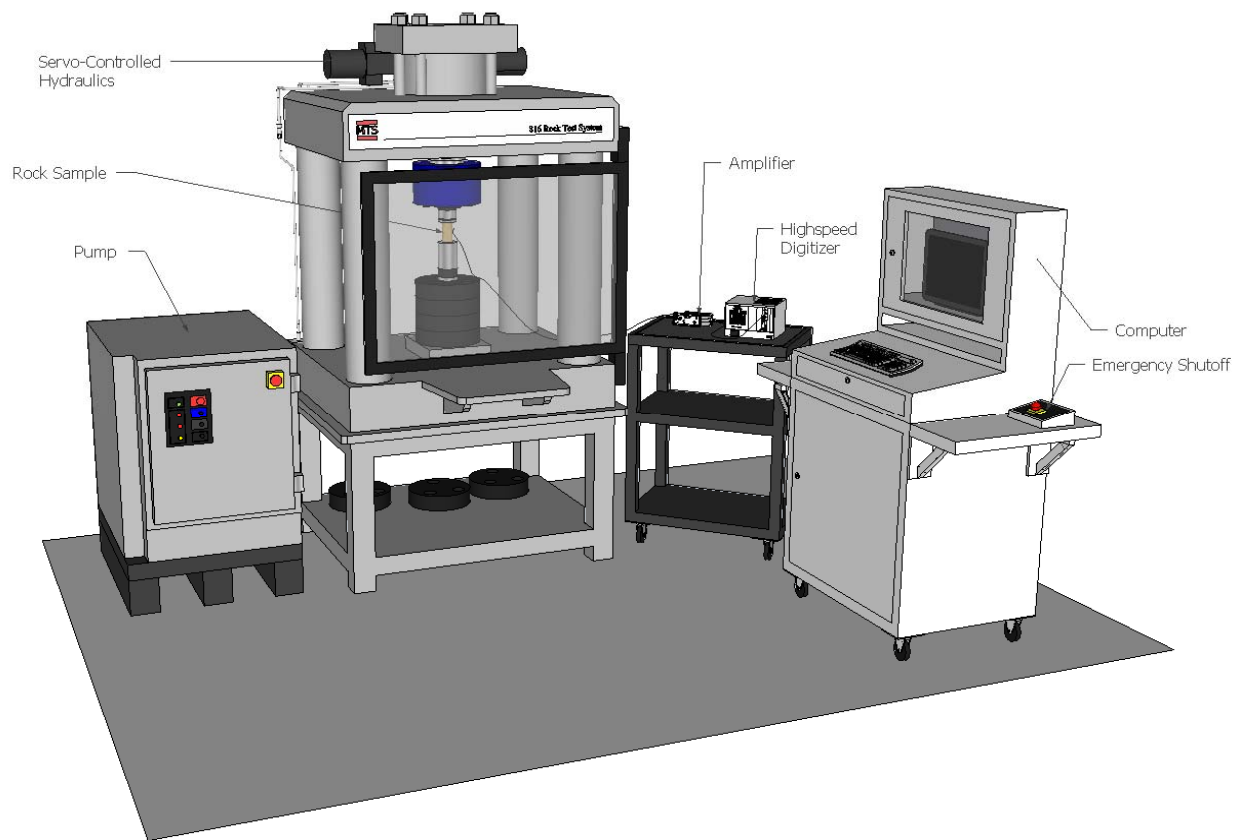

Fig. 7. A close-up picture of the Uniaxial Loading Method

(ARTS), a pre-amplifier, a high-speed digitizer, and two computers; one to control the uniaxial compression machine and the other for the AE acquisition.

For more information on the 816 Rock Test System consult Appendix A. A schematic of the entire MTS 816 Rock Testing System is shown below in Fig. 8.



**Fig. 8.** A layout of the 816 Rock Test System (MTS). Other components include an amplifier and a High-Resolution Digitizer. This system uses a uniaxial loading method on the rock sample.

Another reason the ULM has been chosen is because one of the KISS System goals is to investigate the possibility of using the ULM in a new way. A way that may result in determining the entire in-situ stress tensor rather than just a linear combination of the principal in-situ stresses. The new method hinges on the idea that if the orientation of the maximum principal in-situ stress is known, the in-situ stress tensor can be determined from four different specimens cut at four different orientations from one another that are cut from a single core sample (Fa, et al., 2010).

Appendix C shows how the sample would be cut. Mathematical techniques for determining the principal in-situ stresses are given in Appendix C as well.

The data acquisition portion of the KISS System includes Acoustic Receiving Transducers (ARTs) that will receive waveforms generated during AE activity that send analog signals to a wide band width AE Amplifier. After signal amplification a *National Instruments* high-speed Digitizer will convert all incoming analog signals into digital signals that the selected software can receive and analyze. The selected software will be National Instruments *LabVIEW* because of its ease of graphical coding and signal analysis capabilities.

The high-speed digitizer has a resolution of 16 bit to 24 bit. The advantage of having variable resolution allows a higher sampling rate at a lower resolution or a lower sampling rate at a higher resolution (Fa, et al., 2010). This becomes important when different kinds of rocks are tested.

Section 4.1 explained that brittle rocks have more frequent AE events than soft rocks. Therefore, the sampling rate can be lowered to allow for higher resolution for soft rocks that require higher resolution to detect any AE

activity, and a higher sampling rate for brittle rocks that do not require such high resolution. A picture of the data acquisition components is given in Fig. 9 and the specifications of the high speed digitizer, computer controlled interface and amplifier are given in Appendix B.

In the first stage of experimentation the KISS System will test Hinckley Sandstone, obtained from Hinckley Minnesota. Some of the physical characteristics of Hinckley sandstone are shown in Table 1.

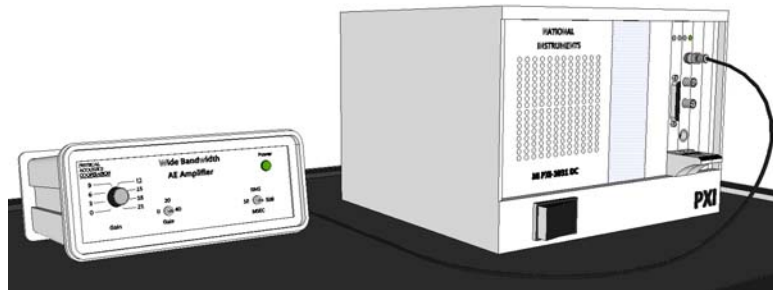

**Fig. 9. Wide Band Width Amplifier (left) and NI Chassis (right) with a High-Resolution Digitizer and Interface card installed.**

**Table 1**

<b>Physical Properties of Hinckley Sandstone</b>	
Porosity	10.57%
Degree of Saturation	3.85%
Point Load Strength	0.0386 (lbf/mm <sup>2</sup> )
Uniaxial Compressive Strength	2500 psi
Young's Modulus	6250000 (psi)
Cohesion Coefficient	722 psi
Internal Angle of Friction	31 °

The sandstone is a good representation for sandstone oil reservoirs and past experimentation has shown sandstone to have a well pronounced Kaiser point (Dunning, et al., 1989). Since the Hinckley sandstone has not been under any forces for a long period of time it will serve as a good control and calibration experiment for the KISS System to verify the ULM for AE and the Kaiser effect. By preloading the sandstone to a desired point below its ultimate strength the KISS System will attempt to replicate the previous known stress via the AE detection rates outlined in Section 4. If the determined Kaiser stress in the second loading cycle correlates with the known stress in the first cycle, then the KISS System is functional and may be expanded further to triaxial testing.

#### **4.5 Procedure**

A detailed procedure guide for the KISS System conducted in uniaxial compression is outlined below:

1. Sample Preparation

- a. Core out a cylindrical sample. Coring is completed in sample preparation lab. The diameter of the sample should be approximately 1 inch and the length of the sample approximately 2 inches. Record the length and diameter with calipers.
  - b. Ensure the samples are cut smoothly and equally as possible. Also, be sure there are no undesired joints or fractures that may create a plane of weakness when the sample is loaded.
  - c. Use a file or sand paper to create a flattened surface on one of the side of the rock sample and 180 degrees on the other side of the sample. This is where the ART's attach. Be sure to not sand off too much rock material as it may diminish the structural integrity of the rock sample.
2. Hardware Setup
- a. Set up the digitizer, computer and amplifier as illustrated in Fig. 8 and 9 (Note that the DAQ program coded in *LabVIEW* is on a different computer than the one that controls the 816 Rock Compression Machine).
  - b. Two ART's need to be attached to the sample. Usually the ART's are attached with super glue located at the area's that have been slightly flattened. A rubber band is also a good way to attach the ART's to the rock sample.
  - c. For connecting the ART's choose Channel 0 as the trigger channel and connect one of the ART's directly to the digitizer port labeled CH 0. Connect the second ART to the amplifier at the location entitled, "Preamplifier". Then connect a cable from the "AE Out" port on the amplifier to the Ch 1 port on the digitizer.  
  
\* If pre amplification is undesired ignore connect each ART directly to the digitizer.
  - d. Once the setup in part c is complete turn on the NI Digitizer followed by the computer with the *LabVIEW* DAQ program (The computer will not recognize the digitizer if it is turned on before the digitizer).

### 3. Running a Test

*\*\*\* remember this is a two cycle test. The first cycle simply loads the rock specimen to a desired stress level, but below its peak strength. The only necessary piece of information in the first cycle is obtaining the maximum stress reached in cycle 1.*

Note: recording AE activity in cycle 1 is not necessary, however, it is a good idea to record AE activity in cycle 1 to get an idea of the sensitivity for the AE in the experiment. All rocks are different, especially for brittle versus ductile rocks.

- a. 793.61 Rock Mechanics Software
  - i. For detailed instruction on using the 793.61 Rock Mechanics Software refer to the user manual.
  - ii. The main concept to keep in mind is that this experiment requires two cycles. The first cycle to pre-stress the rock and the second cycle to analyze acoustic events. Be sure to save the MTS/Force data for later analysis.

*\*\*\* Cycle 2 requires all of the following processes – all programs can be found on the desktop in the folder labeled KISS*

- b. Acoustic Detection Program – *LabVIEW*
  - i. Open the LabVIEW program entitled *DAQ\_Kaiser\_effect.vi* on the computer that is connected to the NI Digitizer. Once the program is open the Front Panel diagram displays the data acquisition program.
  - ii. Using the *DAQ\_Kaiser\_effect.vi*:
    - i. In the *Input* window select Dev: 5922 under *Resources Name*. This will initialize the NI digitizer.
    - ii. In the *Vertical Range* window leave all values as their default values.

- iii. In the *Trigger* window only change the triggering level to the desired level. A smaller trigger level will detect smaller acoustic events. However, too small of a trigger level will trigger from background noise and frictional sliding not AE produced by microcracks.
- iv. In the *Horizontal Range* window change the *Sample Rate* and the number of *Samples per Group* to the desired number. Notice that *Sample Rate/Samples per Group* gives the amount of time the program collects samples after a trigger. Common ranges for the sample rate include high resolution at 500 kS/s and lower resolution at 15 MS/s. See Appendix B for more information.
- v. If all the hardware is setup correctly you are ready for a test.

c. Testing

- i. Prepare the 816 Rock system by moving the compression platen to the point where it just touches the rock sample. DO NOT apply a load at this point to the rock sample.
- ii. Click the run icon on the Front Panel of the *DAQ\_Kaiser\_effect.vi* program. You will be asked to select or create a TDMS file to save your data to. Create the file and select OK.
- iii. Once you have created the file the program will not start acquiring data until an acoustic signal is passed. **IMPORTANT:** Begin the procedure of loading the rock sample with the 793.61 Rock Mechanics Software AND at the same time tap the rock sample with a pen or pencil to initiate data acquisition at the same time that loading begins.



- iv. Monitor the program as it is running. Once the second cycle of compression is completed, click STOP on the Front Panel of the *DAQ\_Kaiser\_effect.vi*.  
IMPORTANT: the program will not terminate until an acoustic signal is passed after selecting STOP. Use your pencil or pen to tap the rock sample to create an acoustic event that will terminate the program.
- v. A window will appear asking if you would like to view your data in the TDMS viewer. Select cancel to end the test or OK to view your data in the *TDMSviewer.vi*.

#### 4. Analyzing the Data

- a. Open the file *Waveform\_Analysis.vi* in LabVIEW.
  - i. On the Front Panel under the *Waveform* tab select which channel to analyze under *Use Channels*. Select the TDMS file created during testing for analysis under *TDMS file*.
  - ii. In the *Time Delay* option select how fast the program runs through the data. For large amounts of data leave the slider at the default value of zero.
  - iii. Optional:
    - **Peak Detection** – If analyzing data based on entire waveform select the OK button under “use Peak Detect vi” on the *Waveform* tab.
    - Under the *Peak Detection* tab select the peak threshold. This finds all peaks in the waveform above the given value and may eliminate unwanted background noise and allows the user to distinguish what is an acoustic event.
- b. Run the program

Upon running the program you will be asked to create an *AE Time file*. The file is a row of all the times in seconds that an acoustic event has taken place. The file can be

viewed in any text or tab delimited viewing software, such as Excel. The program takes only moments to complete *for small amounts of data* and the group number and total number of samples is displayed on the Front Panel.

c. Analyzed Data

Under the *Array* tab is located an array entitled *Group Time Array*. This array contains the times in seconds of each acoustic signal that has been determined as an acoustic event. The first event at time 0 s is not considered since that event initiated the program.

\* If using *Peak Detection* option the time array will be located under the *Peak Detection* tab in the *Locations (Elapsed Time)* array. This data will be saved to the *AE Time file* you created.

5. Correlating AE data and Stress Data – *Datafilter.vi*

- a. Open the file *Datafilter.vi* in the Kaiser Test folder. Select the **AE Time file** and input the file created in the *Waveform\_Analysis.vi*. Also select the **MTS Force/Time file** button and find the created file from the 793.61 Rock Mechanics Software that contains all the time, force and stress and strain data from the experiment.
  - i. These two sets of data contain both time data in seconds. The program searches the MTS Force/Time file for the corresponding times from the AE Time file and returns a file with all the correlated data at times that are within a range of 0.001 seconds.
- b. Run the program – You will be asked to create a *Correlated Time file*. This file contains all the necessary information to construct a cumulative AE graph versus time.
- c. Since both the AE data and the Stress data are functions of time the cumulative number of acoustic events in cycle 2 can be plotted against the stress data. The

resulting graph will be similar to Figure 9. The Kaiser stress is indicated as the inflection point.

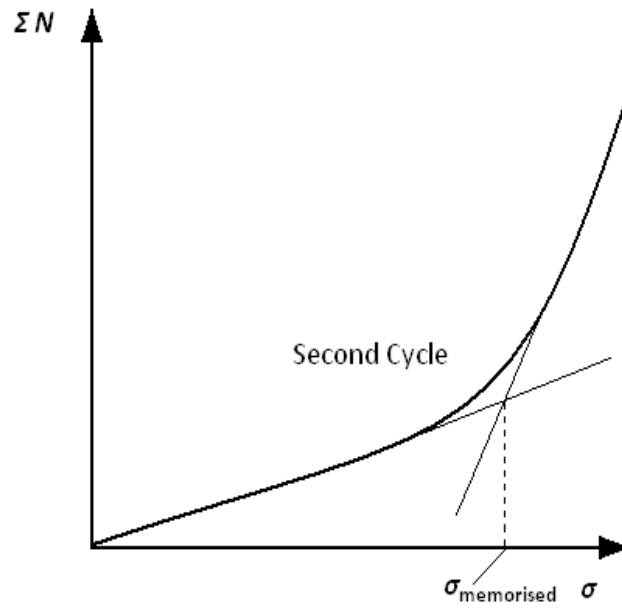

Fig. 10. Inflection in the cumulative AE hits ( $\Sigma N$ ) versus stress ( $\sigma$ ) graph indicates the previous maximum stress state.

## 5. Work Plan

### 5.1 Cost Estimates

#### KAISER IN-SITU STRESS (KISS) SYSTEM COST ESTIMATES

Category	Estimated Quantity	Estimated Cost	Estimated Subtotal
<u>Software/DAQ Equipment</u>			
Acoustic Receiving Transducers (ART)	2	\$ 500.00	\$ 1,000.00
National Instruments LabVIEW Professional	1	\$ 4,299.00	\$ 4,299.00
National Instruments PXI - 1031 DC 4-Slot Chassis	1	\$ 999.00	\$ 999.00
National Instruments PXI - 5922 High Resolution Digitizer	1	\$ 9,499.00	\$ 9,499.00
AE2A Wide Bandwidth Acoustic Emission Amplifier	1	\$ 2,000.00	\$ 2,000.00
NI PXI-8360, MXI-Express Interface	1	\$ 529.00	\$ 529.00
<b>Total</b>			<b>\$ 18,326.00</b>
<u>Hardware</u>			
MTS (Mechanics Testing Systems) 816 Rock Testing System*	1	\$ 300,000.00	\$ 300,000.00
Micellaneous (cables, carts, chairs, tables etc...)		\$ 1,000.00	\$ 1,000.00
<b>Total</b>			<b>\$ 301,000.00</b>

<u>Research</u>				
Initial Software coding and testing (80 hrs @ \$40/hr)	160	\$	40.00	\$ 6,400.00
Data Acquisition Work (40 hrs @ \$65/hr)	80	\$	65.00	\$ 5,200.00
Data Analysis/ Results (40 hrs @ \$40/hr)	80	\$	40.00	\$ 3,200.00
<b>Total</b>				<b>\$ 14,800.00</b>

<b>Grand Total</b>				<b>\$ 334,126.00</b>
--------------------	--	--	--	----------------------

\* The MTS 816 Rock Test System includes: Model 315 Load Frame, Model 643 Compression Platen Fixture, Force Transducers, Strain Transducers and Model 793.61 Rock Mechanics Software. Consult Appendix A for more details

## 5.2 Schedule for the Design Process

The schedule for the design process in Fig. 8 estimates the amount of time needed for a single, qualified geomechanics or rock mechanics engineer to acquire rock samples, code the KISS System, obtain data and analyze the data. The system relies on obtaining a suitable core specimen within two weeks time however, obtaining a good core may take more time and cause the data analysis and results step to be delayed. Other core specimens that imitate oil containing rocks will also be required for the Testing stage. However, these rocks can be rough cut from any rock that has oil containing rock characteristics, such as sandstones, limestone's or shale's.

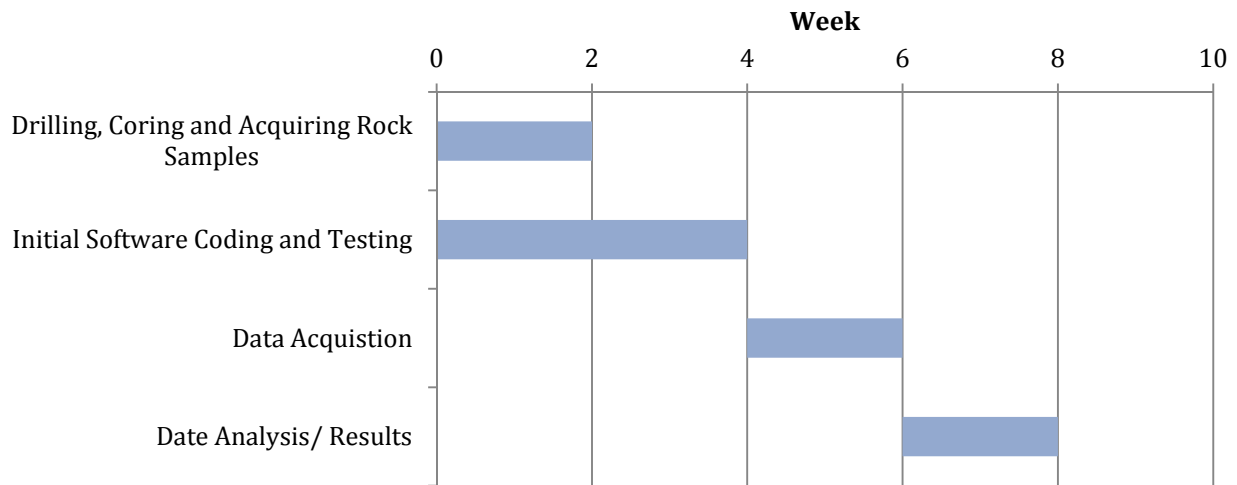

Chart 1. A suggested schedule for the KISS System. Time is in units of weeks

## 6. Data and Analysis

The data presented in this section has been obtained by the author to investigate the plausibility of the KISS System using the ULM and was produced following the procedural guidelines from section 4.5. Graph 1 shows cumulative AE for 126 acoustic events gathered over a time of 22.78 minutes at a loading rate of 0.0003658 mm/s for channel 0. Graph 2 shows cumulative AE versus time considering over 1800 acoustic events. All acoustic events in graph 2 where considered to have amplitudes of 0.001 v or more.

All programs to correlate time data with force data where creates and used by the author. Error between correlating the MTS Force/Time data with the AE data is on the order of 0.001 seconds since that was the range for matching time data.

Graph 1

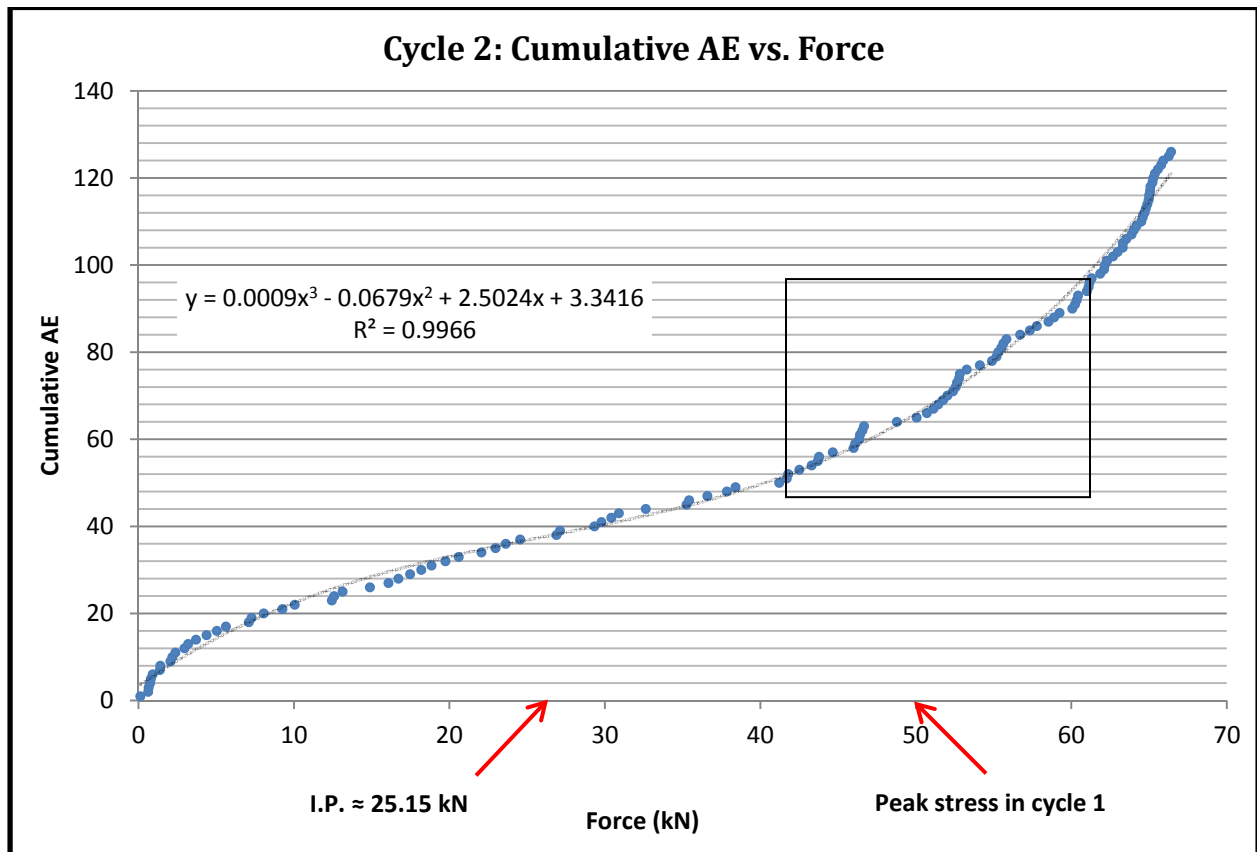

Graph 1 indicates that there is an inflection point at approximately 25.15 kN. This has about a 50% error since the true stress achieved in cycle one was 50 kN. The reason for this discrepancy may be acoustic events that are associated with frictional sliding rather than microcracking has been recorded in graph 1. Another issue is that graph 1 contains only 126 acoustic events. This is a product of the LabVIEW program that recorded the AE. In the program, triggers were considered as the AE event and data that recorded one second after each trigger was ignored. However, considering the boxed section in graph 1 small inflection points in the range of approximately 45 kN to 60 kN are discernible.

In order to mitigate this lack of resolution the entire data set was reanalyzed for over 1800 acoustic events each of which was defined as having amplitude of 0.001 volts. Graph 2 shows the

results of cycle 2 after analyzing over 1800 acoustic events. After close inspection it can be seen in graph 2 that from 0 kN to approximately 50 kN the cumulative AE remains between 0 and 40. However, once the 50 kN point is reached, cumulative AE increase rapidly, especially at the 55 kN point and approximately the 62 kN point. The 50 kN point was the maximum stress level achieved in cycle 1 and thus in cycle 2 the Kaiser effect is observed.

**Graph 2**

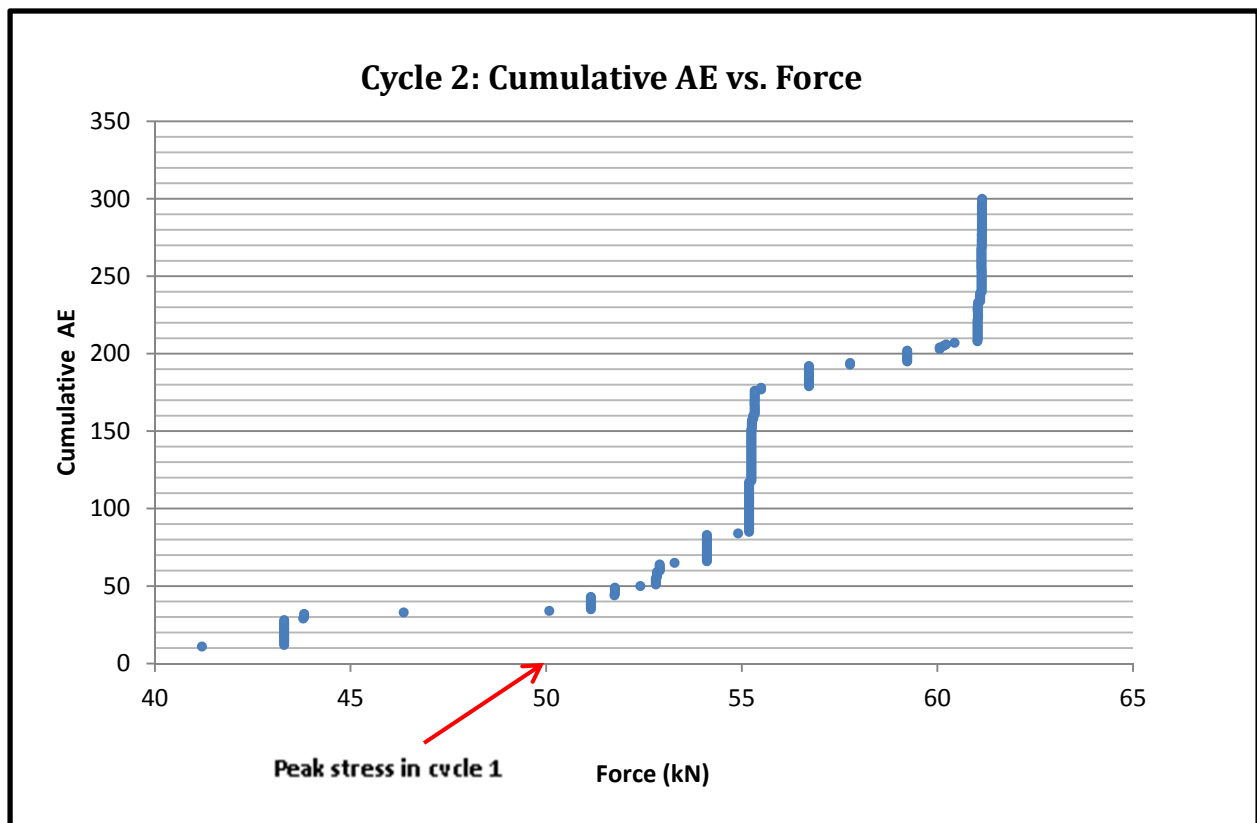



## Conclusion

The KISS System offers the capabilities of determining in-situ stresses in rocks that are non-evasive, relatively cheap and capable of delivering accurate results. AE and the Kaiser effect have been extensively studied and analyzed to determine in-situ stresses in rocks. Many of these attempts to use AE and the Kaiser effect have fallen short due to the lack of sophisticated computing technology. However, the KISS System incorporates the use of high resolution digitizers, servo-controlled compression and a faster computing process to identify stress memory in rocks, where before, computing capabilities could not yield high enough resolution to distinguish stress memory.

Many fundamental problems must be addressed in order for this system to work, however by following the design proposal this system is the initial step to creating a system that can one day calculate the entire stress tensor. Using the KISS System with the uniaxial compression method revealed the Kaiser effect on cyclically loaded Hinckley sandstone, as shown in section 6. The knowledge gained and methods used created a fundamental starting point for more sophisticated experimentation such as, triaxial compression. It is clear that the only way to recreate the entire stress state of a subsurface rock mass is to reload a rock specimen in a triaxial environment. Little work has been produced on this subject, however new ideas and methods are being developed and the first stage of development has been laid out in this paper.

There is much promise for the KISS System. As far as improving the system better waveform filtering techniques such as Fourier transforms, Nyquist frequency and analysis in the frequency domain offers better noise reduction and identification of AE associated with microcracking. Also, better software development would help with time synchronization and data recording. All of these developments will help the KISS System find more accurate and better results.

## Appendices

### Appendix A

Model 816 Multi-purpose Rock and Concrete Testing

## Model 816 Multi-purpose Rock and Concrete Testing System

---

The Model 816 Multi-purpose Rock and Concrete Testing System provides a wide range of laboratory testing capabilities in a modular, low-cost, compact package. This system can be configured in a uniaxial compression-tension, triaxial, or direct shear testing mode.

Modularity in design allows a researcher or instructor to purchase a uniaxial rock and concrete mechanics test system knowing that it can be upgraded in the future to a triaxial or direct shear test configuration. This simple, low-cost system, while not capable of the extremely high compressive force of a Series 315 Load Frames, performs a wide range of tests with a minimal investment of equipment procurement funds and laboratory test space. It is ideal for construction materials or rock mechanics laboratories where research is performed on relatively small specimens, or for instruction in the basic principles of brittle material testing.

A complete Model 816 test system includes the 316 Load Frame configured in the desired testing mode as shown in the illustrations below; a FlexTest controller and personal computer with appropriate application software, and a hydraulic power supply.

Model 816 Multi-purpose Rock and Concrete Testing

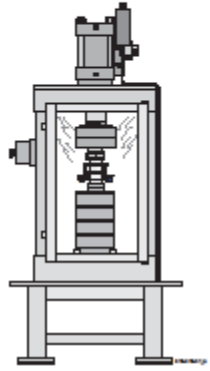

Uniaxial Test Configuration

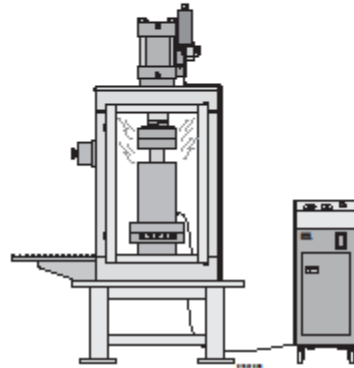

Triaxial Test Configuration

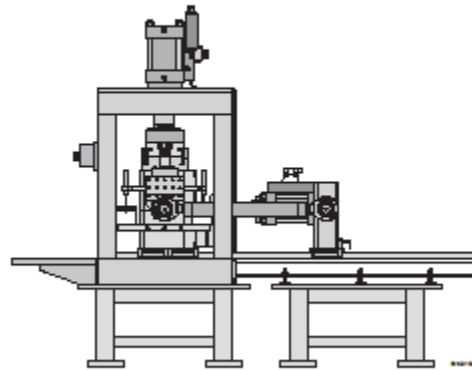

Direct Shear Configuration

## Model 316 Load Frame Assembly

---

The Model 316 Load Frame Assembly is used to apply axial loads to rock or concrete specimens for uniaxial compression, tension, or fracture mechanics tests. The assembly consists of a fixed crosshead mounted on four columns which are bolted to the baseplate, resulting in a rigid, yet free standing frame. The four column design allows access to the test area from all four sides for easy insertion and removal of a wide range of specimen sizes and fixtures. The test area is enclosed by Lexan panels during the test. The test area height is adjusted by using spacer plates for uniaxial testing. The load frame itself rests on a rigid table to provide a convenient working height.

When a triaxial cell is inserted into the test space, the Model 316 Load Frame Assembly applies axial stress to the specimen inside the triaxial cell. A horizontal loading assembly can be attached to the axial load frame to provide a shearing load for direct shear tests. In this configuration, the Model 316 Load Frame Assembly applies the normal load.

The Load Frame assembly is available in four standard sizes based on load capacity. Choosing a load frame depends on the strength and size of the material being tested and the testing requirements. (Refer to the specifications table for the load frame capacities.)

## Model 316 Load Frame Features

---

- |   |   |
|---|---|
| <b>Load Frame</b>   | <ul style="list-style-type: none"> <li>• 4-column, fixed-crosshead design.</li> <li>• Table-top mounting.</li> <li>• Lexan panels on all sides for easy access to test space.</li> </ul>  |
| <b>Actuator</b>   | <ul style="list-style-type: none"> <li>• Single-ended, double-acting design allows testing in compression and tension.</li> <li>• 100 mm (4 in) actuator stroke for tests requiring large displacements.</li> </ul>   |
| <b>Force Measurement</b>  | <ul style="list-style-type: none"> <li>• Force Transducers (standard on 316.01 and 316.02 Load Frames).             <ul style="list-style-type: none"> <li>– Low profile and high stiffness.</li> <li>– Accurate to within <math>\pm 0.5\%</math> of the calibrated range.</li> <li>– Shear web design with preloaded attachment for compression and tension testing.</li> </ul> </li> <li>• Differential Pressure (<math>\Delta P</math>) Transducer (standard on 316.03 and 316.04 Load Frames).             <ul style="list-style-type: none"> <li>– Accurate to within <math>\pm 1\%</math> of the calibrated range above 1000 kN.</li> </ul> </li> <li>• Transducer outputs are conditioned at the Digital Controller for closed-loop control and data acquisition.</li> </ul> |
| <b>Internal Linear Variable Differential Transformer (LVDT)</b> | <ul style="list-style-type: none"> <li>• Calibrated to full scale actuator travel to provide complete positioning control.</li> <li>• Useful for specimen positioning and preloading, and measuring actuator displacement during the test.</li> <li>• Output signal conditioned at the Digital Controller for closed-loop control and data acquisition.</li> <li>• Coaxially mounted inside the actuator piston rod for accurate displacement measurement and reliable operation.</li> </ul>  |

## Model 816 Multi-purpose Rock and Concrete Testing

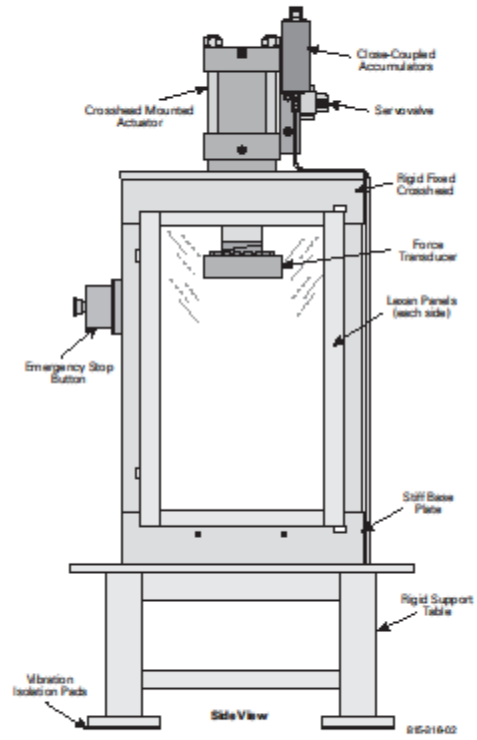

## Model 316 Load Frame Specifications

	Model 316.01	Model 316.02	Model 316.03	Model 316.04
<b>Compression rating</b>				
<b>kN</b>	496	1013	1459	1984
<b>kip</b>	111	227	328	446
<b>Tension rating<sup>*†</sup></b>				
<b>kN</b>	291	648	961	1334
<b>kip</b>	65	145	216	300
<b>Actuator displacement</b>				
<b>mm</b>	100	100	100	100
<b>in.</b>	4	4	4	4
<b>Load frame spring rate<sup>‡</sup></b>				
<b>N/m</b>	$1.1 \times 10^9$	$2.6 \times 10^9$	$2.6 \times 10^9$	$3.0 \times 10^9$
<b>lb/in.</b>	$6.2 \times 10^6$	$1.5 \times 10^7$	$1.5 \times 10^7$	$1.7 \times 10^7$
<b>Parallel alignment between platens</b>				
<b>mm</b>	0.051	0.051	0.051	0.051
<b>in.</b>	0.002	0.002	0.002	0.002
<b>Force Measurement</b>	Force Transducer	Force Transducer	$\Delta P$ Transducer	$\Delta P$ Transducer

\* Although the Load Frame assembly is capable of producing the indicated force in tension, the actual tensile force limit is dependent on the attachment hardware (e.g., threaded connectors) that attach the gripping fixtures to the crosshead and actuator.

† Contact MTS for information regarding the method used to determine load frame spring rate.

Model 816 Multi-purpose Rock and Concrete Testing

## Model 316 Load Frame Floor Loading Footprint Dimensions

	<b>Model 316.01</b>	<b>Model 316.02</b>	<b>Model 316.03</b>	<b>Model 316.04</b>
<b>Length</b>	940 mm 37 in	1118 mm 44 in	1118 mm 44 in	1118 mm 44 in
<b>Depth</b>	686 mm 27 in	762 mm 30 in.	762 mm 30 in	762 mm 30 in

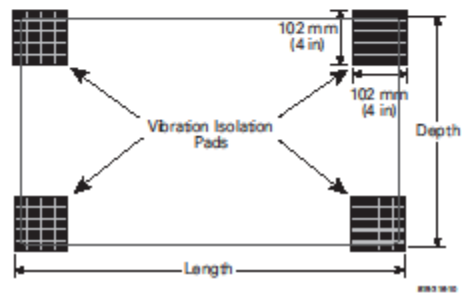



## Model 316 Load Frame Dimensions

Dimensions*	Model 316.01		Model 316.02		Model 316.03		Model 316.04	
	mm	in	mm	in	mm	in	mm	in
A	1115	43.9	1216	47.9	1216	47.9	1213	50.1
B	940	37.0	1048	41.25	1048	41.25	1048	41.25
C	686	27.0	737	29.0	737	29.0	737	29.0
D	724	28.5	724	28.5	724	28.5	724	28.5
E	470	18.5	419	16.5	419	16.5	419	16.5
F	406	16.0	437	17.2	498	19.6	526	20.7
G	816	32.1	816	32.1	816	32.1	816	32.1
H	965	38.0	1118	44	1118	44	1118	44
J			762	30	762	30	762	30
K	457	18.0	610	24	610	24	610	24

\* Refer to the following figure for dimension locations.

## Model 816 Multi-purpose Rock and Concrete Testing

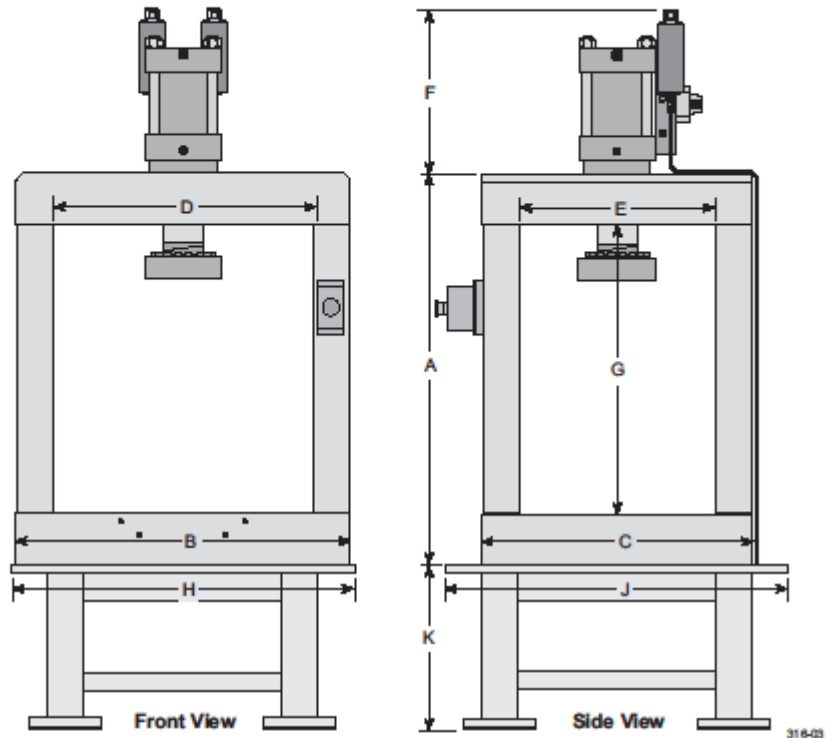

## Appendix B

### NI PXI-5922

#### 24-Bit Flexible-Resolution Digitizer

- 24-bit resolution up to 500 kS/s, ranging to 16 bits at 15 MS/s
- 2 simultaneously sampled channels
- Up to -114 dBc SFDR
- -120 dBFS rms noise
- Integrated antialias protection for all sampling rates
- Deep onboard memory - 8 MB/ch standard, up to 256 MB/ch

#### Overview

The NI PXI-5922 is a dual-channel flexible-resolution digitizer with the highest resolution and highest dynamic range of any digitizer on the market. It maximizes vertical resolution based on the selected sample rate, from 24 bits at rates up to 500 kS/s to 16 bits at 15 MS/s. This unparalleled flexibility and resolution are achieved with NI Flex II ADC technology, which uses an enhanced multibit delta-sigma converter and patented techniques for linearization. By combining the PXI-5922 with software such as NI LabVIEW, you can define functionality to create different instruments, such as DC and rms voltmeters, audio analyzers, frequency counters, spectrum analyzers, IF digitizers, and I/Q modulation analyzers, with measurement performance that exceeds that of high-end traditional instruments with similar functionality.

#### Specifications

##### Specifications Documents

- Specifications
- Data Sheet

##### Specifications Summary

General	
Product Family	Digitizers/Oscilloscopes
Form Factor	PXI Platform
PXI Bus Type	PXI Hybrid Compatible
Part Number	779153-01 , 779153-02 , 779153-03
Operating System/Target	Windows , Real-Time , Linux
LabVIEW RT Support	Yes
Triggering	Analog , Digital
Synchronization Bus (RTSI)	Yes
External Clocking	No

<b>Length</b>	16 cm
<b>Width</b>	10 cm
<b>Height</b>	2 cm
<b>I/O Connector</b>	SMB male , BNC connectors
<b>Power Requirement for +3.3V Rail</b>	2 A
<b>Power Requirement for +5V Rail</b>	1.4 A
<b>Power Requirement for +12V Rail</b>	330 mA
<b>Power Requirement for -12V Rail</b>	280 mA
<b>Slot Two Module</b>	No
<b>Module Width</b>	1
<b>MXI Compatible</b>	Yes
<b>Product Name</b>	PXI-5922
<b>Analog Input</b>	
<b>Channels</b>	2
<b>Resolution</b>	24 bits
<b>Simultaneous Sampling</b>	Yes
<b>Sample Rate</b>	15 MS/s
<b>Bandwidth</b>	6 MHz
<b>Input Impedance</b>	50 Ohm , 1 MOhm
<b>Maximum Common Mode Voltage</b>	42 V
<b>On-Board Memory</b>	256 MB/ch
<b>Frequency Range</b>	0 Hz , 6 MHz
<b>Max Voltage</b>	-5 V , 5 V
<b>Maximum Voltage Range Sensitivity</b>	596 nV
<b>Minimum Voltage Range</b>	-1 V , 1 V
<b>Supports Alias Protected Decimation?</b>	No
<b>Provides Digital Down Conversion?</b>	No
<b>Spurious-Free Dynamic Range</b>	114 dBc
<b>Total Harmonic Distortion (THD)</b>	-112 dBc

<b>Signal-to-Noise-and-Distortion Ratio (SINAD)</b>	105 dB
<b>Phase Noise</b>	-133 dBc/Hz
<b>Analog Output</b>	
<b>Channels</b>	0
<b>Digital I/O</b>	
<b>Channels</b>	0

© 2011 National Instruments Corporation. All rights reserved. For information regarding NI trademarks, see [ni.com/trademarks](http://ni.com/trademarks). Other product and company names are trademarks or trade names of their respective companies. Except as expressly set forth to the contrary below, use of this content is subject to [the terms of use for ni.com](#).

National Instruments permits you to use and reproduce the content of this model page, in whole or in part; provided, however, that (a) in no event may you (i) modify or otherwise alter the pricing or technical specifications contained herein, (ii) delete, modify, or otherwise alter any of the proprietary notices contained herein, (iii) include any National Instruments logos on any reproduction, or (iv) imply in any manner affiliation by NI with, or sponsorship or endorsement by NI of, you or your products or services or that the reproduction is an official NI document; and (b) you include the following notice in each such reproduction:

"This document/work includes copyrighted content of National Instruments. This content is provided "AS IS" and may contain out-of-date, incomplete, or otherwise inaccurate information. For more detailed product and pricing information, please visit [ni.com](http://ni.com)."

## NI PXI-ExpressCard8360

### Laptop Control of PXI with ExpressCard

- Direct laptop control of PXI/CompactPCI
- Software transparent link that requires no programming
- Sustained throughput up to 110 MB/s
- Cabling up to 7 m with rugged screw-in connectors
- Ability to use the same PXI module and cable as MXI-Express

## Overview

With the National Instruments PXI-ExpressCard8360 kit, you can transparently control PXI and CompactPCI systems from a laptop computer with either an ExpressCard/34 or ExpressCard/54 slot. The PXI-ExpressCard8360 kit consists of an ExpressCard-8360 card in the laptop connected via an ExpressCard MXI cable to an NI PXI-8360 module in slot 1 of a PXI chassis. The ExpressCard-8360 card provides a x1 (by one) PCI Express link that is cabled to the PXI-8360 module. The PXI-8360 module includes a bridge that converts the cabled PCI Express link to the PCI bus that is used in PXI. Thus, all PXI modules appear to you as if they are PCI boards within the laptop computer itself. For a list of laptop computers that are compatible with the PXI-ExpressCard8360 kit, visit [PXI-ExpressCard8360 Compatible Laptop Computers](http://PXI-ExpressCard8360 Compatible Laptop Computers). To configure a complete PXI system based on a PXI-ExpressCard8360 kit, visit [ni.com/pxiadvisor](http://ni.com/pxiadvisor).

## Specifications

### Specifications Documents

- Specifications (4)
- Data Sheet

## Specifications Summary

General	
Product Name	PXI-ExpressCard8360
Form Factor	PXI Platform
PXI Bus Type	PXI Only
Part Number	779507-03
Operating System/Target	Windows , Real-Time
LabVIEW RT Support	Yes
Controller	
Controller Type	Remote
Communication Technology	PCI Express
Sustained Performance	110 MB/s
Cable Material	copper
Maximum Cable Length	7 m
Electric Isolation	No
Software Support for NI System Monitor	No
Maximum Links per Host Card	1
Slot Requirement	1
PXI Power Req - max current for 3.3 V Rail	1.75 A
PXI Power Req - max current for 5 V Rail	20 mA
PXI Power Req - max current for +12 V Rail	20 mA
PXI Power Req - max current for -12 V Rail	0 mA
PC Power Req - max current for 3.3 V Rail	280 mA
Physical Specifications	
Length	16 cm
Width	10 cm
Minimum Operating Temperature	0 °C
Maximum Operating Temperature	55 °C
Maximum Altitude	2000 m

© 2011 National Instruments Corporation. All rights reserved. For information regarding NI trademarks, see [ni.com/trademarks](http://ni.com/trademarks). Other product and company names are trademarks or trade names of their respective companies. Except as expressly set forth to the contrary below, use of this content is subject to [the terms of use for ni.com](http://ni.com/terms).

National Instruments permits you to use and reproduce the content of this model page, in whole or in part; provided, however, that (a) in no event may you (i) modify or otherwise alter the pricing or technical specifications contained herein, (ii) delete, modify, or otherwise alter any of the proprietary notices contained herein, (iii) include any National Instruments logos on any reproduction, or (iv) imply in any manner affiliation by NI with, or sponsorship or endorsement by NI of, you or your products or services or that the reproduction is an official NI document; and (b) you include the following notice in each such reproduction:

"This document/work includes copyrighted content of National Instruments. This content is provided "AS IS" and may contain out-of-date, incomplete, or otherwise inaccurate information. For more detailed product and pricing information, please visit [ni.com](http://ni.com)."

## Appendix C

Recent developments for determining the Kaiser Effect without using triaxial compression are based on cutting plugs out of core samples as shown in the figure below. Equations for determining the principle stresses are given as:

$$\sigma_v = \sigma_{v0} + \alpha p_p$$

$$\sigma_H = \frac{\sigma_{0^\circ} + \sigma_{90^\circ}}{2} + \frac{\sigma_{0^\circ} - \sigma_{90^\circ}}{2} (1 + \tan^2 2\theta)^{1/2} + \alpha p_p$$

$$\sigma_h = \frac{\sigma_{0^\circ} + \sigma_{90^\circ}}{2} - \frac{\sigma_{0^\circ} - \sigma_{90^\circ}}{2} (1 + \tan^2 2\theta)^{1/2} + \alpha p_p$$

$$\tan 2\theta = \frac{\sigma_{0^\circ} + \sigma_{90^\circ} - 2\sigma_{45^\circ}}{\sigma_{0^\circ} + \sigma_{90^\circ}}$$

$\sigma_v$  = vertical principal stress

$\sigma_H$  = maximum horizontal principal stress

$\sigma_h$  = minimum horizontal principal stress

$\alpha$  = effective stress coefficient

$p_p$  = pore pressure

$\sigma_{v0}$  = Kaiser stress in the vertical direction

$\sigma_{0^\circ}$ ,  $\sigma_{45^\circ}$ ,  $\sigma_{90^\circ}$  = Kaiser stress in the plugs orientated at directions 0, 45 and 90 respectively. See Fig. ###.

$\theta$  = angle between the  $0^\circ$  direction and the maximum horizontal principal stress direction

(Fa, Zeng, & Liu, 2010)

The validity of this process could be determined using the KISS System.

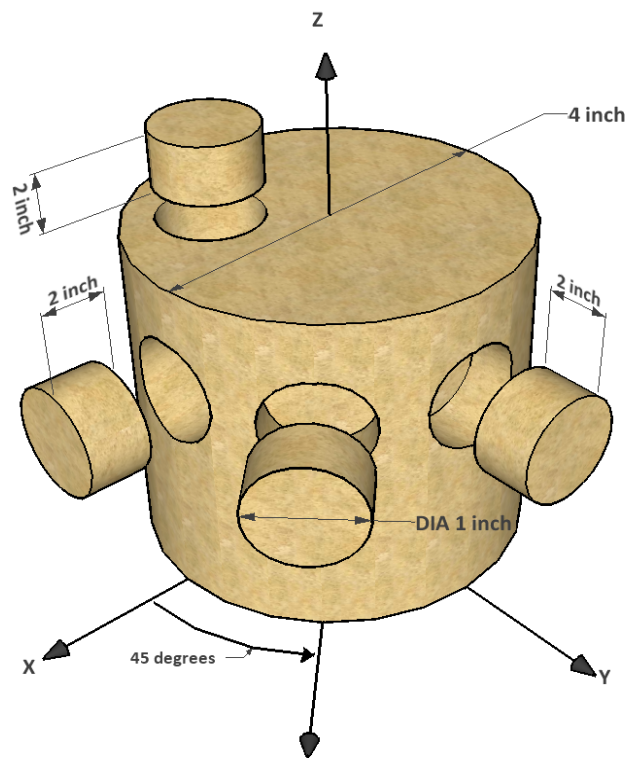



## References

- Dunning, J. D., Leaird, J. D., & Miller, M. E. (1989). The Kaiser effect and frictional deformation. *Fourth Conference on AE/MA in Geologic Structures and Materials* (pp. 3-13). Clausthal-Zellerfeld: Trans Tech Publications.
- Fa, L., Zeng, Z., & Liu, H. (2010). A New Device for Measuring In-situ Stresses by Using Acoustic Emission in Rocks. *44th US Rock Mechanics Symposium*. Salt Lake: American Rock Mechanics Association.
- Filimonov, Y., Lavrov, A., Shafarenko, Y., & Shkuratnik, V. (2002). Observation of post-failure Kaiser effect in a plastic rock. *Pure Applied Geophysics*, 1321-1331.
- Holcomb, D. J. (1993). General Theory of the Kaiser Effect. *International Journal of Rock Mechanics & Mining Sciences*, 929-935.
- Kaiser, J. (1953). Erkenntnisse und Folgerungen aus der Messung von Gerauschen bei Zugbeanspruchung von metallischen Werkstoffen. *Archiv Eisenhüttenwesen*, 43-45.
- Kurita, K., & Fujii, N. (1979). Stress memory of crystalline rocks in acoustic emission. *Geophysical Research Letters*, 9 - 12.
- Lavrov. (2001). Kaiser effect observation in brittle rock cyclically loaded with different loading rates. *Mech Mater*, 669-677.
- Lavrov, A. (2003). The Kaiser effect in rocks: principles and stress estimation techniques. *International Journal of Rock Mechanics & Mining Sciences*, 151-171.
- Lavrov, A. (1997). Three-dimensional simulation of memory effects in rock samples. In: *Rock Stress. Proceedings of the International Symposium on Rock Stress* (pp. 197-202). Rotterdam: A.A. Balkema.
- Ljunggren, C., Chang, Y., Janson, T., & Christiansson, R. (2003). An overview of rock stress measurement methods. *International Journal of Rock Mechanics & Mining Sciences*, 975-989.
- Michihiro, K., Yoshioka, H., & Hata, K. F. (1989). Strain dependence of the Kaiser Effect for various rocks. *Fourth Conference on AE/MA* (pp. 87-95). Clausthal-Zellerfeld: Trans Tech Publication.
- Stevens, J., & Holcomb, D. (1980). A theoretical investigation of the sliding crack model of dilatancy. *Journal of Geophysical Research*, 7091-7100.
- Yoshikawa, S., & Mogi, K. (1989). Experimental studies on the effect of stress history on acoustic emission activity - a possibility for estimation of rock stress. *Journal of Acoustic Emission*, 113-123.