

Performance Test and Structural Analysis of Cross-Flow Turbine

Zar Ni Tin Win^{a*}, Htay Htay Win^b, Myint Thein^c

^{a,b,c}Department of Mechanical Engineering, Mandalay Technological University, Mandalay, Myanmar

^aEmail: zarnitinwin@gmail.com

^bEmail: htayhtayw@gmail.com

^cEmail: minmyintthein2008@gmail.com

Abstract

Myanmar is a developing country; the annual consumption of electricity has been increasing rapidly throughout the country. The main source of energy for generating electricity is hydropower because of her hilly regions with rivers and water-falls. Myanmar, where 75% of the populations live in rural area, has a low level of access to electricity. Small-scale hydropower production may be the most cost-effective way to supply electricity to remote villages that are not near transmission lines. The objectives of this research is to design low cost with high efficient cross-flow turbine especially for low head, to analyze the blade structural and modal of the turbine runner by using ANSYS 14.5 software, to construct the designed cross-flow turbine and test the performance of constructed cross-flow turbine in selected site location. The designed cross-flow turbine is capable of producing up to 300 watts AC power at the head of 6m and water flow rate of 0.009 m³/s.

Keywords: Analysis; cross-flow turbine; design; hydropower; performance.

1. Introduction

Hydropower is an ancient technology that has been used throughout the world as a natural source of energy for several hundreds of years. The role of hydro plants becomes more and more important in today's global renewable energy.

* Corresponding author.

The small-scale renewable generation may be the most cost effective way to supply electricity to remote villages that are not near transmission lines.

There are various types of turbines for hydro power plants. The selection of the best turbine for any particular hydro site depends on the site characteristics, the dominant ones being the head and flow available.

Selection also depends on the desired running speed of the generator or other device loading the turbine. Cross-flow turbine is the best type for hilly regions with low head and high flow rate [2]. The cross-flow turbine is a machine which provides shaft power by extracting energy from a moving fluid. The fluid is guided into the rotor by inlet jet or nozzle.

The fluid is then flows through the first rotor, through the interior, through the second rotor and through the exit. Due to the change in angular momentum of the fluid across the rotor, a torque is applied to the output power shaft.

The output power shaft can be used to drive a water pump, an electric generator or a compressor. A typical cross-flow turbine consists of two main components namely the nozzle and the runner. The power transfer process takes place on the surface of the runner blades. The blades are assembled on a disc that is supported by a shaft; the whole assembly is technically known as runner.

A nozzle, which converts the potential energy to kinetic energy of water that crosses the runner two times is known as cross-flow and the name of the turbine is derived from this phenomenon [1].

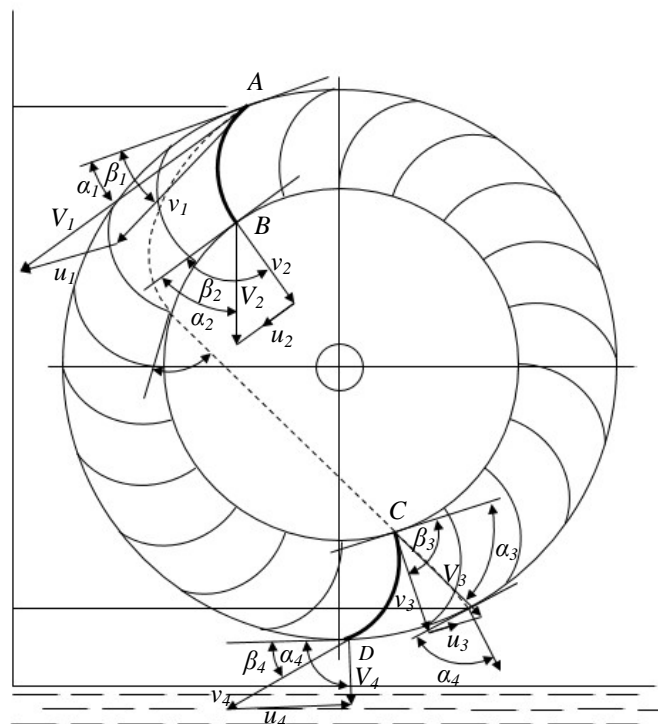

Figure 1: path of water through turbine

Figure 1 illustrates the path of water through turbine. The water starts enter from point A and strikes a blade AB. Then through the interior of the runner. The water strikes again to a blade CD and pass through the exit.

2. Design Procedure of the Cross-Flow Turbine

The calculations for design procedure of the cross-flow turbine runner involves the following steps.

Table 1: Parameters considered for design

Parameters	Amount	Unit
Generator output power	300	watts
Head	6	m
Turbine runner speed	650	rpm
Angle of attack	16	degree
Blade angle	30	degree

Table 1 shows the parameters considered for designing 300 watts cross-flow turbine. The calculations for parameters of cross-flow turbine are calculated by using Banki's theory.

2.1. Calculation of the design output of turbine

The design output for turbine can be calculated as

$$P_G = \frac{P_T}{\eta_g} \quad (1)$$

2.2. Calculation of the required water flow rate

The required water flow rate for 300 watts cross-flow turbine can be calculated as

$$Q = \frac{P_{out}}{\rho g Q H \eta_0} \quad (2)$$

2.3. Calculation of the mass flow rate

The water mass flow rate can be calculated as

$$\dot{m} = \rho Q \quad (3)$$

2.4. Calculation of the velocity of water before entering

The velocity of water before entering can be calculated as

$$V_1 = C\sqrt{2gH} \quad (4)$$

2.5. Calculation of the outer diameter of runner

The outer diameter of cross-flow turbine runner can be calculated as

$$D_1 = 39.85 \frac{\sqrt{H}}{N} \quad (5)$$

2.6. Calculation of the length of runner, L

The length of runner is equal to the length of nozzle. The length of runner for cross-flow turbine can be calculated as

$$L = \frac{Q}{kD_1C\sqrt{2gH}} \quad (6)$$

2.7. Calculation of the number of blades

The number of blades for turbine runner can be calculated as

$$n = \frac{\pi D_1}{t} \quad (7)$$

2.8. Calculation of the radius of inner circle, r_2

The radius of inner circle for turbine runner can be calculated as

$$r_2 = 0.66r_1 \quad (8)$$

2.9. Calculation of the radius of blade curvature, ρ

The radius of blade curvature for turbine runner can be calculated as

$$\rho = 0.326r_1 \quad (9)$$

2.10. Calculation of the radius of pitch circle, r_0

The radius of pitch circle for turbine runner can be calculated as

$$r_0 = 0.73r_1 \quad (10)$$

2.11. Calculation of the central angle of blade

The central angle of blade can be calculated as

$$\delta = 2 \tan^{-1} \left(\frac{\cos \beta_1}{\sin \left(\beta_1 + \frac{r_2}{r_1} \right)} \right) \tag{11}$$

2.12. Calculation of the diameter of shaft

The diameter of shaft for turbine runner can be calculated as

$$d_s^3 = \frac{16}{\pi \omega_s} \sqrt{(K_b M_b)^2 + (K_t M_t)^2} \tag{12}$$

The design parameters were calculated by using the above equations. Table 2 shows the design result data for 300 watts cross-flow turbine.

The range for angle of attack is 16° to 22° and the angle of attack 16° is choose for micro hydropower production [1].

Table 2: Result data for 300 watts cross-flow turbine

Parameters	Symbol	Result	Unit
Angle of attack	α	16	degree
Blade angle	β	30	degree
Runner diameter	D_1	150	mm
Runner length	L	76	mm
Number of blades	n	20	-
Radius of inner circle	r_2	50	mm
Radius of blade curvature	ρ	24	mm
Radius of pitch circle	r_0	55	mm
Central angle of blade	δ	73.5	degree
Blade thickness	t	3	mm
Diameter of shaft	d_s	25	mm

By using result data, the curvature of blade for blade design was illustrated as shown in Figure 2.

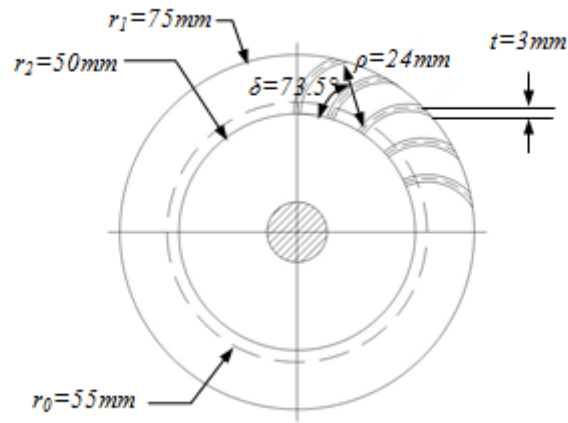

Figure 2: curvature of blade for blade design

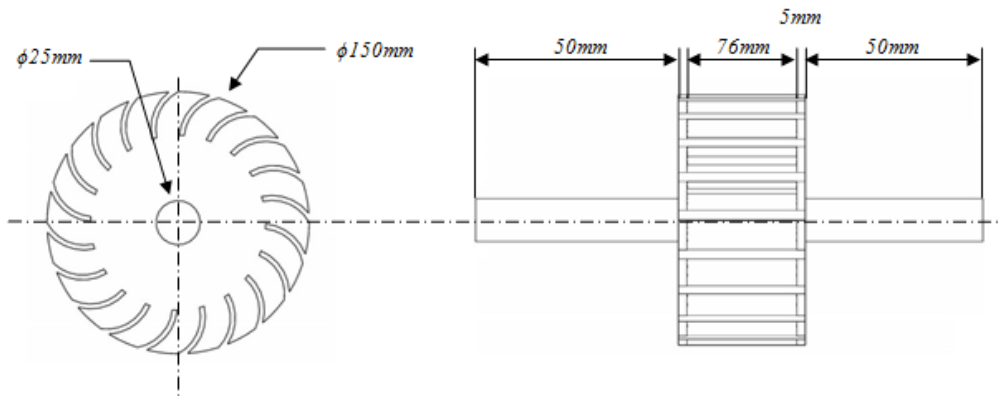

Figure 3: parameters of side view and front view of turbine runner

Figure 3 shows the designed parameters of the side view and front view of turbine runner. Figure 4 shows the model of cross-flow turbine.

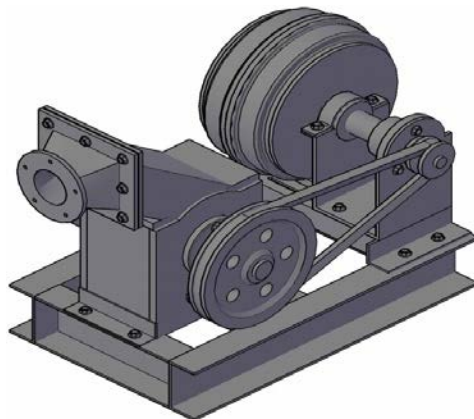

Figure 4: model of cross-flow turbine

3. Static Structural Analysis of Cross-Flow Turbine Runner Blade

The designed cross-flow turbine runner blade 3D model was generated with AutoCAD software and analyze in ANSYS 14.5. The blade was analyzed with mass flow rate 8.5 kg/s, rotational velocity 650 rpm, angle of attack 16° and blade angle 30° and three locally available material. The input geometry was generated in AutoCAD with result parameters.

3.1. Design procedure for static structural analysis

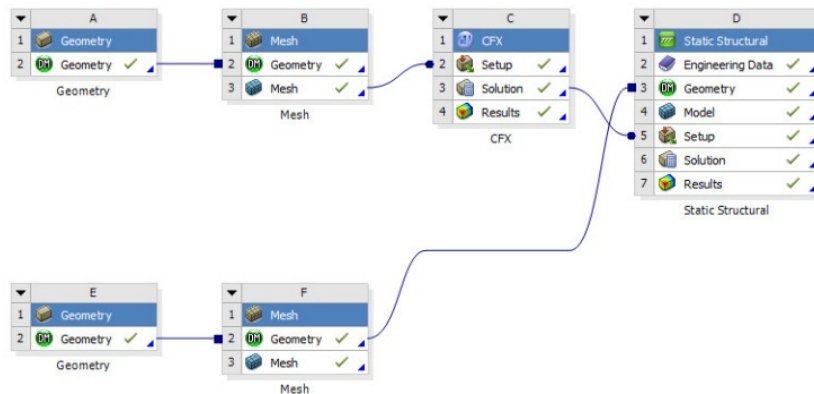

Figure 5: design procedure for static structural using ANSYS 14.5

Figure 5 illustrates procedure for static structural analysis using ANSYS 14.5. The model of the cross flow turbine blade was generated in AutoCAD with two types of model; blade for CFX model which have inlet angle of 16° as shown in Figure 6 and blade for static structural model as shown in Figure 7.

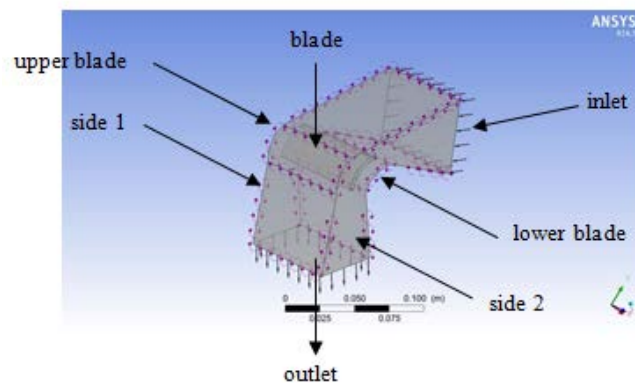

Figure 6: boundary conditions of blade for CFX model

The fluid flow model was added to the geometry in ANSYS 14.5. This geometry model was meshed with high smoothing. This meshed model was imported to CFX-Pre and add inlet conditions. The blade rotating speed was 650 rpm counter-clockwise and give other boundary conditions of blade, inlet, outlet, side 1 and side 2 for runner disc, and the two sides for upper blade and lower blade. After adding inlet conditions, run the solution

for 500 iterations. The result was convergent from 350 iterations and stop at 500 iterations. This result was saved to add the inlet conditions for structural testing. The structural blade model was added to the geometry in ANSYS 14.5. This geometry model was meshed with high smoothing. This meshed model was imported to static structural for static structural analysis of the blade. Engineering data for type of material and use the structural steel for first testing material. Then, give the input conditions which get from the fluid flow model and fixed the two sides of the blades. After finishing setup, run the solution and get the equivalent (von-Mises) stress and total deformation for static structural analysis of the cross-flow turbine runner blade.

The three types of locally available material, namely the structural steel, aluminium alloy and copper alloy were used for the blade materials.

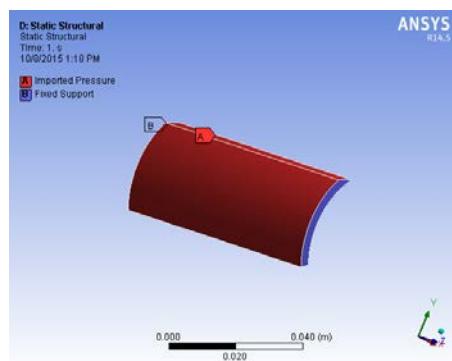

Figure 7: boundary conditions of blade for static structural model

Figure 7 illustrates boundary conditions of blade for static structural analysis.

3.2. Static structural analysis of the runner blade using three different materials

The deformation on runner blades using structural steel, aluminium alloy and copper alloy are illustrated in Figure 8, Figure 10 and Figure 12. The von-Mises stress on runner blades using structural steel, aluminium alloy and copper alloy are illustrated in Figure 9, Figure 11 and Figure 13.

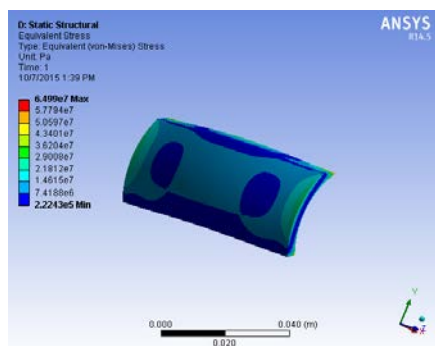

Figure 8: deformation on runner blade using structural steel

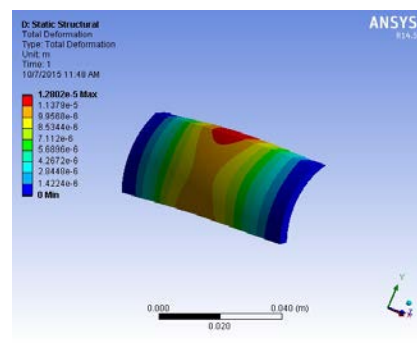

Figure 9: von-Mises stress on runner blade using structural steel

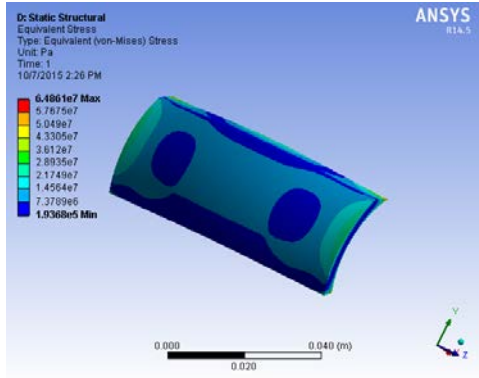

Figure 10: deformation on runner blade using aluminium alloy

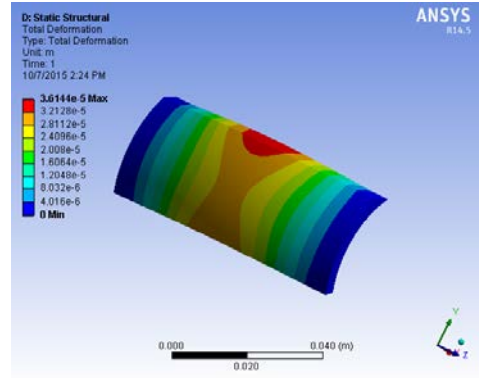

Figure 11: von-Mises stress on runner blade using aluminium alloy

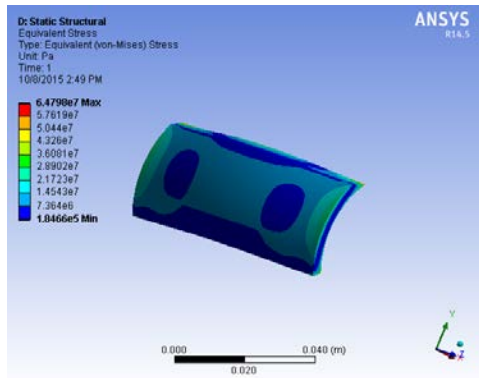

Figure 12: deformation on runner blade using copper alloy

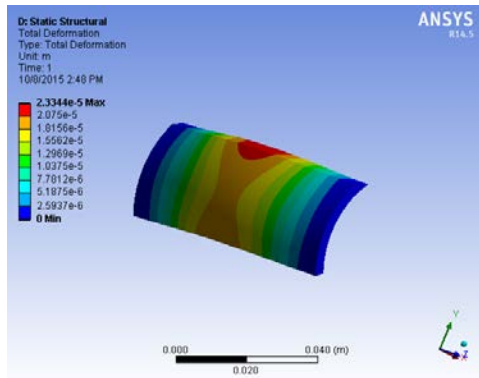

Figure 13: von-Mises stress on runner blade using copper alloy

The resulted data for static structural analysis with three types of materials are compared with total deformation and von-Mises stress as shown in Table 3.

Table 3: Total deformation and von-Mises stress for three types of materials

Materials	Structural steel	Aluminium alloy	Copper alloy
Total deformation (displacement)	0.0128 m	0.0361 m	0.0233 m
Von-Mises stress	64.99 MPa	64.86 MPa	64.79 MPa
Yield strength	250 MPa	280 MPa	250 MPa

The von-Mises stress on blade using different materials are nearly the same.

The deformation analysis shows that displacement of the blade with structural steel has minimum displacement and choose the structural steel for suitable material in this research. So, the cross-flow turbine blade was constructed with structural steel to get the best performance with longer life time.

4. Modal Analysis of Cross-Flow Turbine Runner

Modal analysis in structural mechanics is used to determine the natural mode shapes and frequencies of an object or structure during free vibration. The designed turbine operates at 650 rpm. So, the corresponding working frequency can be calculated as

$$f_n = \frac{\omega}{2\pi} \quad (13)$$

So, the corresponding working frequency for 650 rpm is 10.83 Hz.

4.1. Six Global Mode Shapes

A modal of cross-flow turbine was imported to ANSYS 14.5 and setting up the boundary conditions for modal analysis of cross-flow turbine runner as shown in Figure 14.

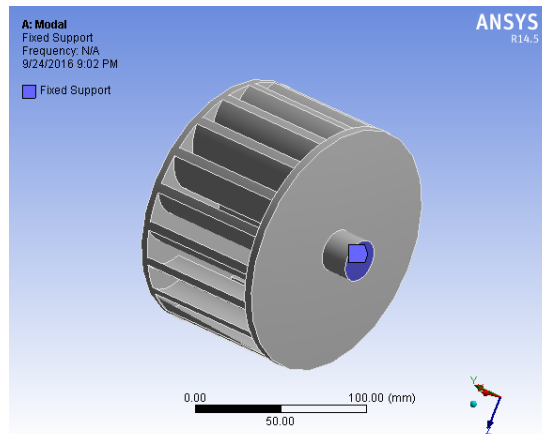

Figure 14: boundary conditions for modal analysis of cross-flow turbine runner

By performing modal analysis, the following six global mode shapes are obtained by using ANSYS 14.5.

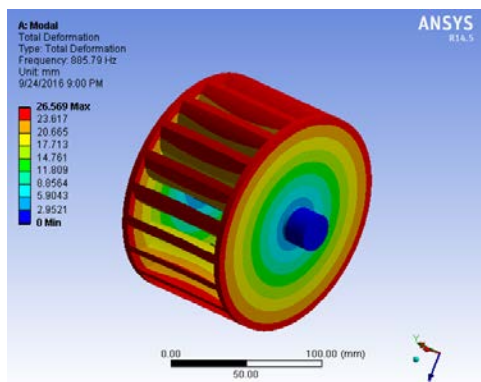

Figure 15: mode shape 1

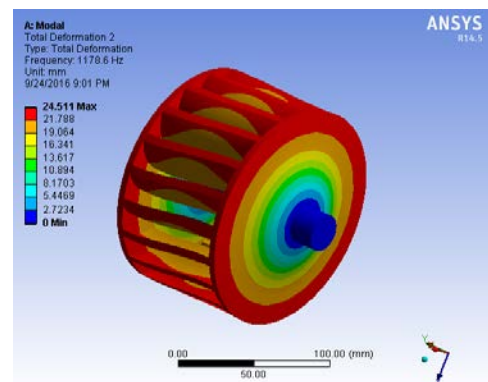

Figure 16: mode shape 2

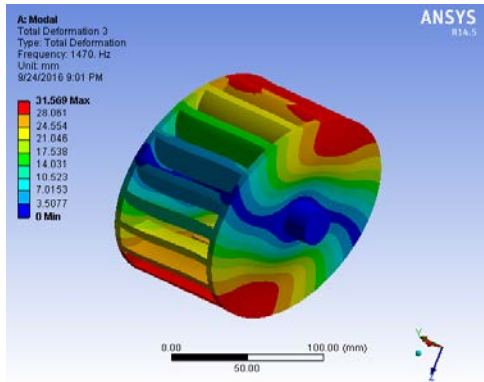

Figure 17: mode shape 3

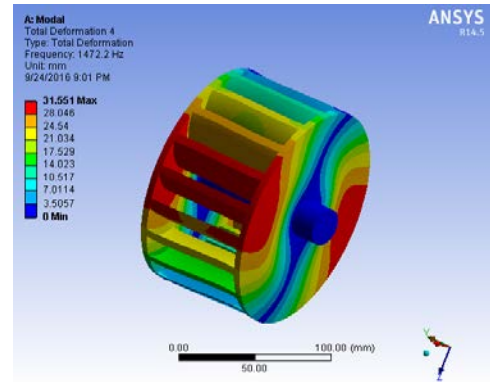

Figure 18: mode shape 4

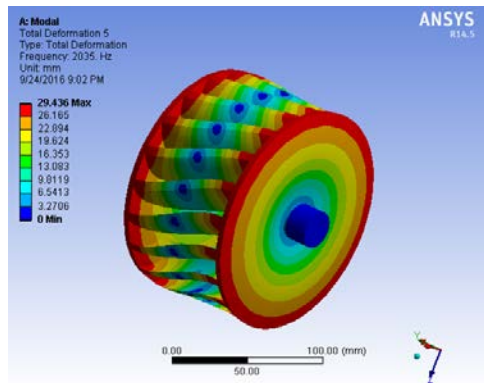

Figure 19: mode shape 5

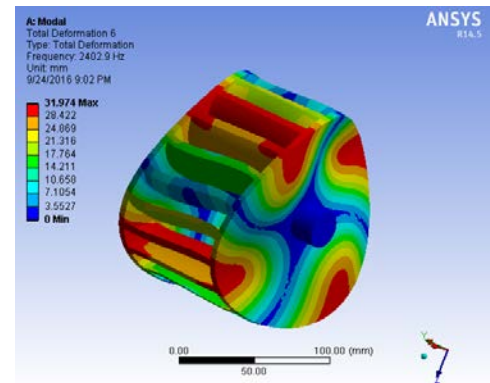

Figure 20: mode shape 6

From the results of modal analysis, the following natural frequencies for six global mode shapes are required.

Table 4: Natural frequencies for six global mode shapes

Mode shape	1	2	3	4	5	6
Natural frequency	885.79 Hz	1178.6 Hz	1470 Hz	1472.2 Hz	2035 Hz	2402.9 Hz

Table 4 shows the natural frequencies for six global mode shapes. Natural frequencies for six global mode shapes are 885.79 Hz, 1178.6 Hz, 1470 Hz, 1472.2 Hz, 2035 Hz and 2402.9 Hz respectively. The designed turbine operates at 650 rpm so the working frequency is 10.83 Hz. From the modal analysis, it is clear that the working frequency of the runner and natural frequencies of runner for six global mode shapes do not match so the turbine structural has no tendency of resonance and the structure for designed turbine is safe.

5. Construction of Cross-Flow Turbine

The construction of cross-flow turbine parts were carried out after completion of the design work. All the manufacturing activities were carried out at local workshop except standard parts such as bearings, bolts and

nuts etc. which were purchased from the market. The results of the research ensure availability of a model and documented procedures for designing, constructing and testing of cross-flow turbine in Myanmar.

5.1. Blades

The number of blades for designed cross-flow was 20 blades with thickness 3 mm.

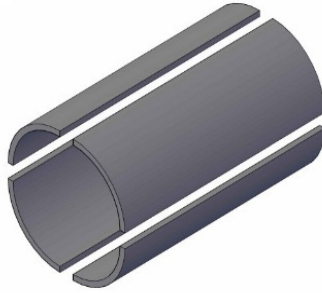

Figure 21: cutting blades from section pipe

The blades in this experiment were cut out of hollow steel pipes with thickness 3 mm corresponding to the blade angle as calculated by Banki theory. Figure 21 shows cutting blades from section pipes.

5.2. Runner

The runner side discs with thickness 5 mm is cut and trim for 20 blades using CNC lathe machine as shown in Figure 22.

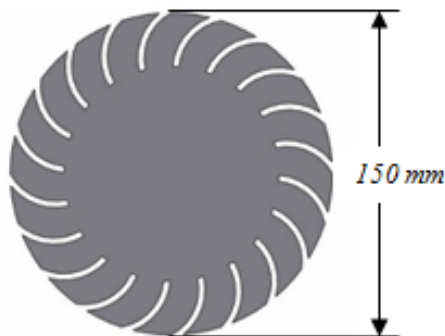

Figure 22: runner side disc

The blades are fit into slots of two side discs of 150 mm diameter with thickness 5 mm and weld it. The central shaft of 25.4 mm diameter is also welded to the rotor discs. Figure 23 shows the constructed cross-flow turbine runner with pulley and flywheel.



Figure 23: runner with pulley and flywheel

5.3. Nozzle

A nozzle in the cross-flow turbine guides and control the water flow into the runner. The water flow rate can be varied by changing the guide vane in the nozzle as shown in Figure 24. Its shaft is parallel to the rotor shaft; it fits neatly inside the nozzle to keep leaks. It guides water to the runner and controls the amount of water entering the runner. The guide vane is controlled by using a hand wheel.

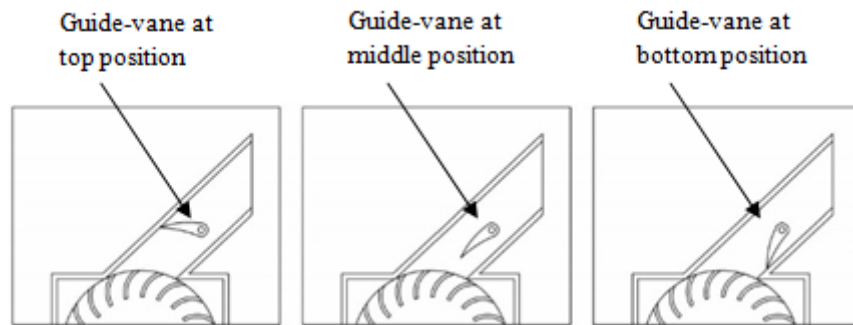

Figure 24: three positions of guide vane

5.4. Casing

The casing was made up of 5 mm in thick mild steel, having 25.4 mm diameter steel shaft with the runner mounted on it passed through along with the bearings. The nozzle was attached on top of the casing. The side covers are screwed together for easy set-up and dismantling, and hence to facilitate the fast and easy replacements for various tests. Figure 25 shows the assembly of casing, runner and nozzle. Two bearings (NSK 6205 DU) are used for runner mounted on casing.



Figure 25: assembly of casing with runner and nozzle

5.5. Adapter

At the entry of the nozzle, the square parts of the nozzle need to transmit to the circular shape of the 50.8 mm penstock pipe. So, adapter is used to change the circular inlet to square outlet as shown in Figure 26.



Figure 26: adapter used in cross-flow turbine

5.6. Selection of generator

Hydro systems use AC generator either induction or synchronous to supply AC electrical appliances. Permanent magnet generator is selected as it is much cheaper and has smaller overall size.



Figure 27: 300 watts generator for water turbine

This type of generator is more efficient because no power is wasted to generate the magnetic field. This generator is imported from China which is producing 300 W output power. Figure 27 shows the 300 W output permanent magnet generator.

5.7. Assembly of cross-flow turbine

Each designed part is constructed and combined into a set of cross-flow turbine to test the performance at the selected site location. The cross-flow turbine is connected with generator by using pulley and belt system which increase the speed ratio from 1:3 to the generator. A-36 v-belt type is used for this pulley and belt system.

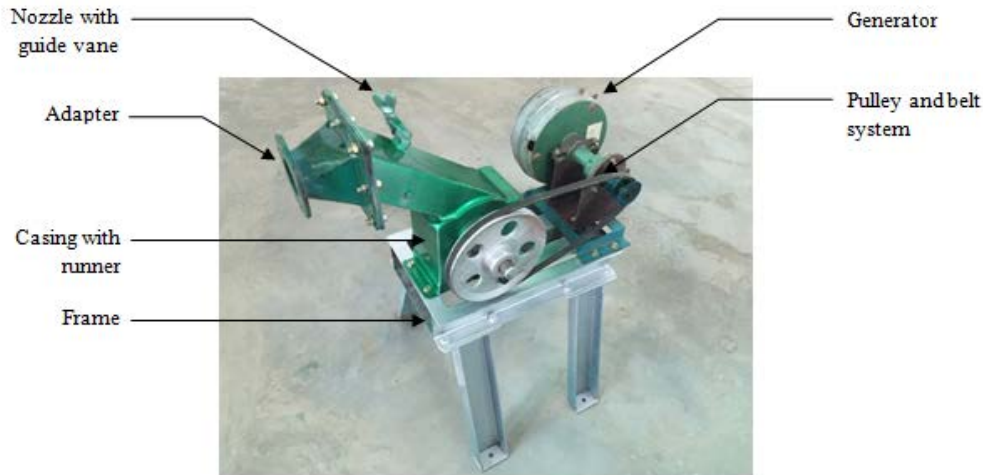

Figure 28: assembly of cross-flow turbine

Figure 28 shows the complete assembly of cross-flow turbine to test the performance at the selected site location.

6. Performance Test of Cross-Flow Turbine

The selected site is located at the Mya Kha Nauk Mountain near Mandalay Technological University. The water is free flowing from the site location to the bottom of the mountain. There is a water fall at site location and reservoir is located at the base of waterfall. A 50.8 mm diameter penstock pipe is connected between reservoir and the turbine. The maximum flow rate is 0.009 m³/sec and head is 6 m. The water flow rate is controlled by changing the gate valve angle from 0 degree to 90 degree full opening. The nozzle guide vane is also adjusted to test the speed of runner shaft. The turbine speed and generator speed was measured at different position of guide vane using tachometer. Water flow rates are measured by using bucket method. The voltage and ampere are measured with digital clamp multimeter. Two tests were conducted. In the first test, gate valve opened at 90° full opening and the rotating speeds of the runner shaft (not connecting with generator) is measured with tachometer by changing three positions of guide vane (top, middle, and bottom). The results of which are shown in Table 5.

Table 5: Speeds of runner at different positions of guide vane with no loads

Head, m	Vane adjustment	Runner speed
6	top	425
6	middle	475
6	bottom	430

At this experiment, the best guide-vane position is at middle producing runner speed 475 rpm.

In the second test, the turbine is connected with generator by using pulley and belt system. The penstock pipe is connected with gate valve to control the flow rate of water and test the performance of the turbine with gate valve angle 30°, 60° and 90° (full opening). From the graph in Figure 29, the generator shaft speeds are compared with three position of guide-vane angle depending on the inlet flow rate which is controlled by using gate valve.

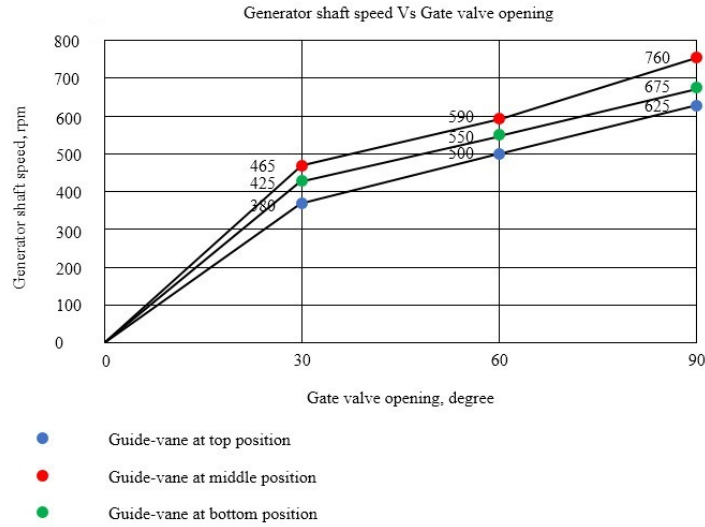

Figure 29: graph showing the relationship between gate valve opening, degree and generator shaft speed, rpm

The graph showing the relationship between flow rate and power output are shown in Figure 30. Finally, the flow rate vs efficiency are shown in Figure 31.

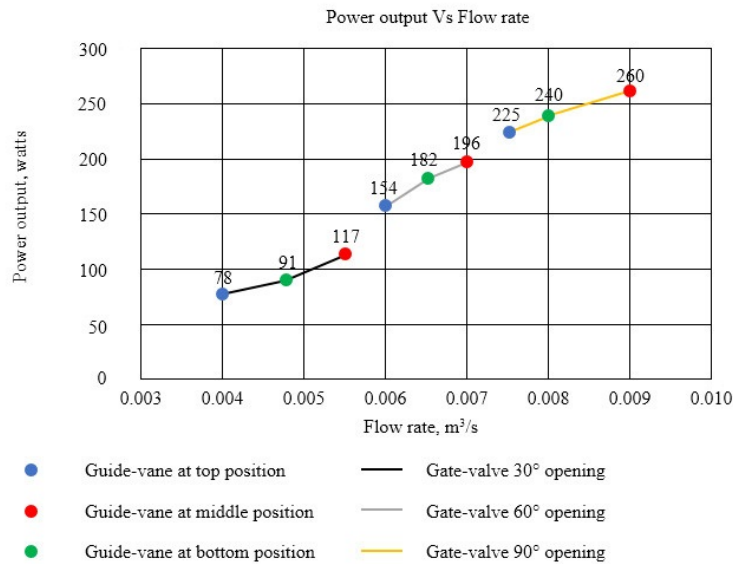

Figure 30: graph showing the relationship between flow rate, m³/s and power output, watts

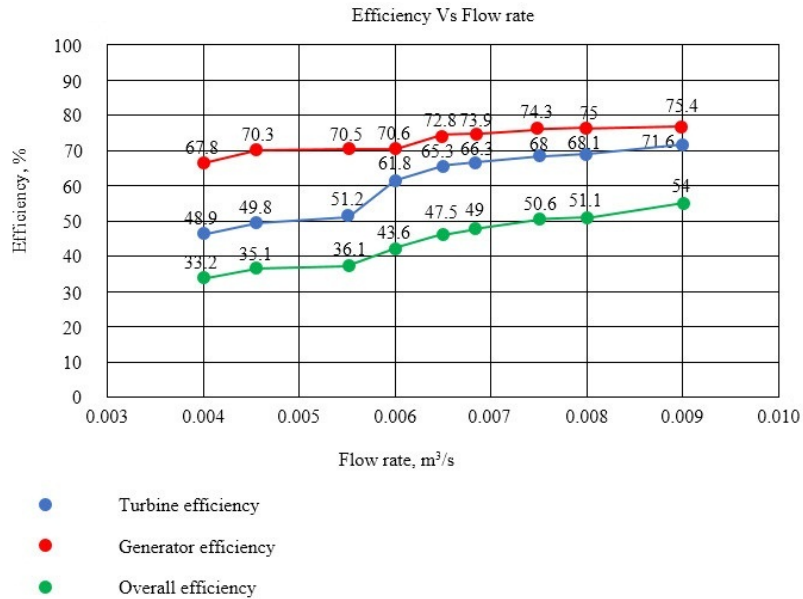

Figure 31: graph showing the relationship between flow rate, m³/s and efficiency, %

7. Results and Discussion

A complete design of cross-flow turbines has been presented in this paper. The complete design parameters of runner diameter, runner length, blades number, runner speed, radius of blades curvature and turbine power were determined at maximum turbine efficiency. Static structure analysis has been carried out on turbine blade made of different materials which are suitable for turbine blade namely structural steel, aluminium alloy and copper alloy by using ANSYS 14.5 software. In this research, the von-Mises stress on the blade is 64.99 MPa, 64.86 MPa and 64.79 MPa respectively while the yield strength is 250 MPa for structural steel, 280 MPa for aluminium alloy and 250 MPa for copper alloy. So, the blade will work safely at this stress. Maximum deformation on the blade is 0.0128 mm, 0.0361 mm and 0.0233 mm on the center of the blade which are much lower to cause any distortion in the structure.

Modal analysis has been carried out on turbine runner and analyze the natural frequencies at global mode shapes. Structural steel was used for the material properties and the designed turbine working frequency was 10.83 Hz and natural frequencies for global mode shapes were 885.79 Hz, 1178.6 Hz, 1470 Hz, 1472.2 Hz, 2035 Hz and 2402.9 Hz respectively. As the working frequency of the runner and natural frequencies of runner do not match so the turbine structural has no tendency of resonance. In all global mode shapes, the structure is safe so our designed turbine is safe.

Construction is carried out after completion of the design work using available technology at local workshop. The designed cross-flow turbine is compact, cheap and high efficient for low head situation. Performance test is conducted at selected site location which has net head 6 m with water flow rate 0.009 m³/s. The results of the performance tests were recorded and illustrated into graphs. The designed cross-flow turbine can produce 260 watts power output for the selected location.

8. Conclusion

The cross-flow turbine is suitable for pico hydropower production in case of low head and flow rate. The designed cross-flow turbine runner blade was analyzed with static and modal analysis. From the obtained results, it is clear that the turbine blades with three types of materials was not fail. In this research, the suitable material is structural steel because three types of blade materials have nearly the same von-Mises stress on blade but structural steel has lowest deformation on blades. Also, the working frequency do not match with natural frequencies of the runner at global mode shape. So, the designed turbine is safe for both structural and modal analysis.

The performance test is conducted with three position of water flow rate by changing the angle of gate valve. In each position of gate valve, the guide-vane position in the nozzle with top, middle and bottom position are changed and tested the generator shaft speed, output voltage, ampere, power output and efficiency. From the performance result, it is clear that the cross-flow turbine need more flow rate to get higher power output as shown in Figure 29, 30 and 31. The designed cross-flow turbine can produce highest power output 260 watts by using flow rate $0.009 \text{ m}^3/\text{sec}$ at 90° full opening from the gate valve and at middle position of nozzle guide-vane.

Acknowledgements

First of all, the author is particularly intended to Dr. Tin San, Associate Professor and Head of Department of Mechanical Engineering, Mandalay Technological University, for his encouragement, constructive guidance and kindly advice throughout the preparation of this paper. Special appreciation is intended to his supervisor Dr. Htay Htay Win, Associate Professor, Mandalay Technological University, for her supervision, support, guidance and encouragement throughout this study. Moreover, the author also would like to thank his friends for their kind help. Special thanks are given to his parent, brothers and sisters for their constant understanding, encouragement and support to make this research without any difficulty.

References

- [1] C. A. Mockmore and Fred Merryfield. (1949, February). The Banki Water Turbine. Bulletin Series No.25.
- [2] L. A. Haimerl. (1960, January). The Cross-Flow Turbine.
- [3] F. O. Ruud. (1962). Stress Analysis of Hydraulic Turbine Parts.
- [4] Mohammad Durali. (1976). Design of Small Water Turbines for Farm and Small Communities.
- [5] Hitoshi Yamamoto. (1983). Cross-Flow Hydraulic Turbine and Their Power Generations. Series 68.
- [6] P. Verharrrt. (1983, March). Blade Calculations for Water Turbines of the Banki Type.
- [7] Nadim M. Aziz and Venkappayya R. Desai. (1991). A Laboratory Study to Improve the Efficiency of Cross-Flow Turbine.
- [8] A. Harvey. (1993). Micro Hydro Design Manual. Intermediate Technology Publications.
- [9] W. S. Tickoo. (2012). ANSYS Workbench 14.0 for Engineers and Designers.
- [10] Felix Mtalo. (2010). Design and Fabrication of Cross-Flow Turbine.

- [11] Muhammad Adil Khan and Saeed Badshah. (2014). Design and Analysis of Cross-Flow Turbine for Micro Hydropower Application using Sewage Water. ISSN 2040-7459.
- [12] http://www.borstengineeringconstruction.com/Cross_Flow_Turbine_Design_Calculator.html
- [13] Anonymous. Hydraulic Engineering Manual.
- [14] Thi Thi Moe. "Design and Construction of Turbines for Hydropower Plants." Ph.D Thesis, Yangon Technological University, 2004.
- [15] Pa Pa Min. "Design and Construction of 300 watts Cross-Flow Turbine." Ph.D Thesis, Yangon Technological University, 2007.
- [16] Aye Mya Thandar. "Design of 100 kw Cross-Flow Turbine for Mini Hydropower Plant." Ph.D Thesis, Mandalay Technological University. 2007.