

# Superheated Steam Temperature Control using Fuzzy Logic Controller

Hozifa Bushra<sup>a\*</sup>, Osman Fadul-Elmoula<sup>b</sup>, Yaser Hamad-Elneel Ibrahim<sup>c</sup>,  
Eltaher Mohamed Hussein<sup>d</sup>, Dalia Mahmoud<sup>e</sup>

<sup>a,b,c,e</sup>Department of Electronic Engineering, Alneelain University, Khartoum, Sudan

<sup>d</sup>Department of Biomedical Engineering, Sudan University of Science and Technology, Khartoum, Sudan

<sup>a</sup> Email: Hozufa15@gmail.com

<sup>b</sup> Email: Osman.eng2007@hotmail.com

<sup>c</sup> Email: ysrhamad@hotmail.com

<sup>d</sup> Email: altaher33@yahoo.com

<sup>e</sup> Email: d.daliamahmoud@yahoo.com

## Abstract

This paper describes the application of a modern model based controller utility to control the steam superheat temperature. The steam superheat temperature control is critical to the efficient operation of utility boiler steam turbines. Traditional controllers may cause a significant time delay when used in this application. A fuzzy Logic controller are designed and well tuned to control the steam temperature of the boiler. The results obtained demonstrated the Fuzzy logic controller surpassing over the conventional methods.

**Keywords:** Fuzzy logic controller; PID; Simulink; Boiler; Superheater; Fuzzy rul; Membership function; MST.

## 1. Introduction

The control system in the boiler temperature of the power plants represents a very complex and nonlinear control system. This is because firstly it depends on a number of factors (boiler load and the rate of change in the load, air flow, etc.), and secondly because the system response for the control signal usually takes a long time [1].

In the boiler system, the control is made in the Main Steam Temperature (MST), which should be within a specific limit and not allowed the temporary deviation exceed  $\pm 10$  °C and the long-term deviation doesn't exceed  $\pm 5$  °C. Significant increase in MST value leads to pipeline damage, and the significant decline in its value reduces the thermal efficiency and leads to the turbine blade corrosion [2].

---

\* Corresponding author.

Several techniques are used to control the steam temperature. One of these techniques is water injection, where the system is cooled using a device known as attemperator (or desuperheater) which injected amounts of water in order to cool the system and keep MST within the required limits. Typically PID controllers are used to control the output of this device and the spray rate from it [3].

This paper proposes a method for controlling the water injection using Fuzzy Logic Controllers (FLC). Fuzzy logic has been successfully applied to a large number of control applications [4]. It works efficiently on the nonlinear and complex systems which are difficult to accurately measure their output. It also speeds up the response of the system and this is very desirable advantage of the previous system.

Basic operations in fuzzy logic based on fuzzification the inputs and then building the fuzzy rules through which the output can be found. And finally defuzzification the output to give the correct control action to the system.

Many of studies and experiments were made to control the STM using different methods. Begum and his colleagues [5] presents the tuning of PID controller for superheated steam temperature system control using modified Zeigler tuning Algorithm.

Tomas [6] deals with the improvement of a boiler superheated steam temperature fuzzy control. He optimized the fuzzy parameters and then made a comparison between the responses of the fuzzy controller before and after the optimization.

Pranita [7] was attempted to design a fuzzy logic controller for steam temperature control using PIC 16F871 microcontroller.

### 1. Superheat steam temperature system model

Our model represents the transfer function of an Attemperator (valve) controlled by FLC.

“Attemperators are utilized in Heat Recovery Steam Generators (HRSG’s) between the primary and secondary superheaters on the High Pressure (HP) and the Reheat (RH) lines (Figure 1). In some designs, attemperators are also added after the final stage of superheating” [8].

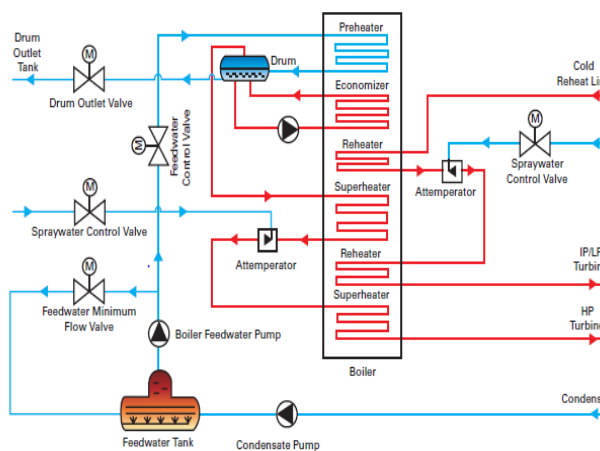

**Figure 1:** Superheat and Reheat Attemperators [8]

1. Design of the fuzzy logic controller

For the system of STM control, the inputs are the difference between the system actual temperature and the desired temperature (the error), and the rate of change of this error. The output is the valve position. Figure 2 shows the block diagram for the system.

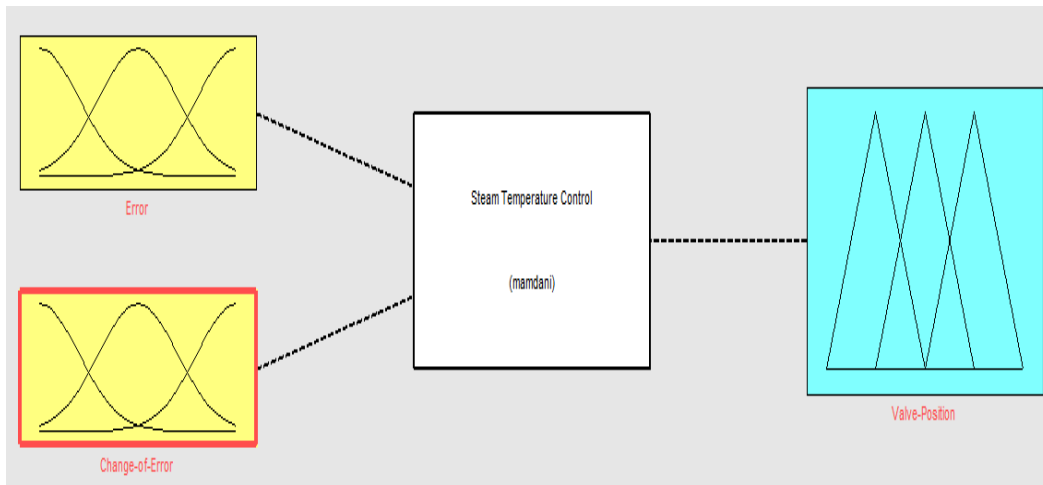

**Figure 2:** Steam temperature control using FLC Block diagram

The FLC has two input variable error (E) and error rate (CE) and one output variable to control valve position. Names of the fuzzy sets used for inputs and output are PB (positive Big), PS (Positive Small), Z (Zero), NS (Negative Small), NB (Negative big).

1. Membership functions

The membership functions of inputs and output are shown in fig (4) and fig (5). Suitable ranges are chosen for this variable in membership function. Triangular membership function is preferred since fast response is necessary for the system. The design of FLC was involved the following steps:

Step1: Define membership functions for the state variables. The values are shown in table (1) and Figure (3).

**Table 1:** Membership values of the temperature (input)

	500	510	520	530	540	550	560
<b>PB</b>	0	0	0	0	0	0.1	1
<b>PS</b>	0	0	0	0	0.2	1	0
<b>Z</b>	0	0	0	1	0	0	0
<b>NS</b>	0.1	0.3	0.9	0.1	0	0	0
<b>NB</b>	0.5	1	0.4	0	0	0	0

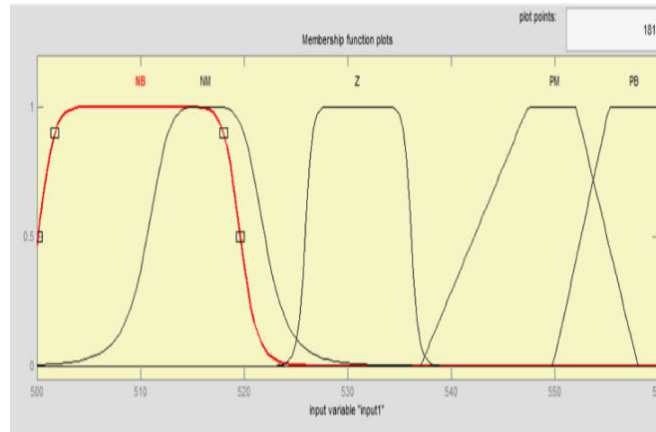

Error

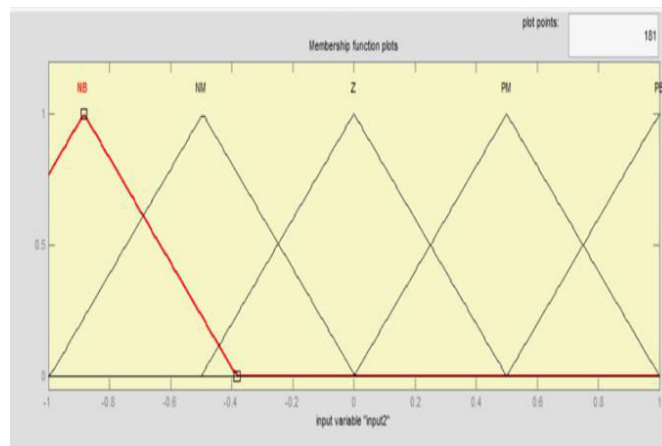

Rate of change in error

**Figure 3:** Membership function for inputs E & CE

Step2: Define a membership function for the valve position output, as shown in table (2) and Figure (4) below:

**Table 2:** Membership values of the valve position (output)

	0	0.2	0.4	0.6	0.8	1.0	1.2	1.4
PB	0	0	0	0	0	0	0	1
PS	0	0	0	0	1	.15	0.1	0
Z	0	0	0.1	1	0	0	0	0
NS	0	0.3	0.7	0	0	0	0	0
NB	1	0.8	0	0	0	0	0	0

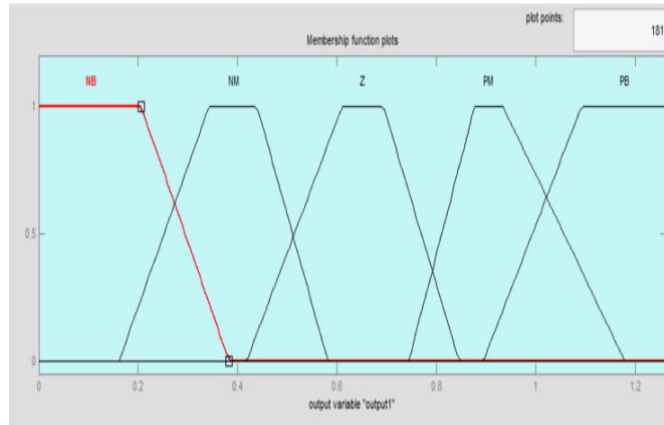

**Figure 4:** Membership function for output

1. Fuzzy rule base

The rules are formed based on error and change in error. Rules base are given in Table 3. When the actual temperature is greater than the set value, the controller is in cool mode. The controller sets the motor angle for opening and closing of the spray valve. There are Five membership function of error and change in error therefore we get 25 fuzzy rules. Some of expert fuzzy rules applicable for this controller are:

- (1) If (ERROR is NB) and (ERROR RATE is NB) then (CONTROL is NB).
- (2) If (ERROR is NB) and (ERROR RATE is NS) then (CONTROL is Z).
- (24) If (ERROR is PB) and (ERROR RATE is PS) then (CONTROL is PB).
- (25) If (ERROR is PB) and (ERROR RATE is Z) then (CONTROL is NS).

**Table 3:** Fuzzy Rule Base

E CE	NB	NS	Z	PS	PB
NB	NB	PS	PB	PB	NB
NS	Z	NS	NB	NS	NB
Z	PS	PB	NS	Z	NS
PS	PB	PB	PS	PB	PB
PB	PS	PB	PB	PB	PB

The following figure (Figure 5) shows the system without controller, the system with FLC and the system with

PID designed using MATLAB Simulink.

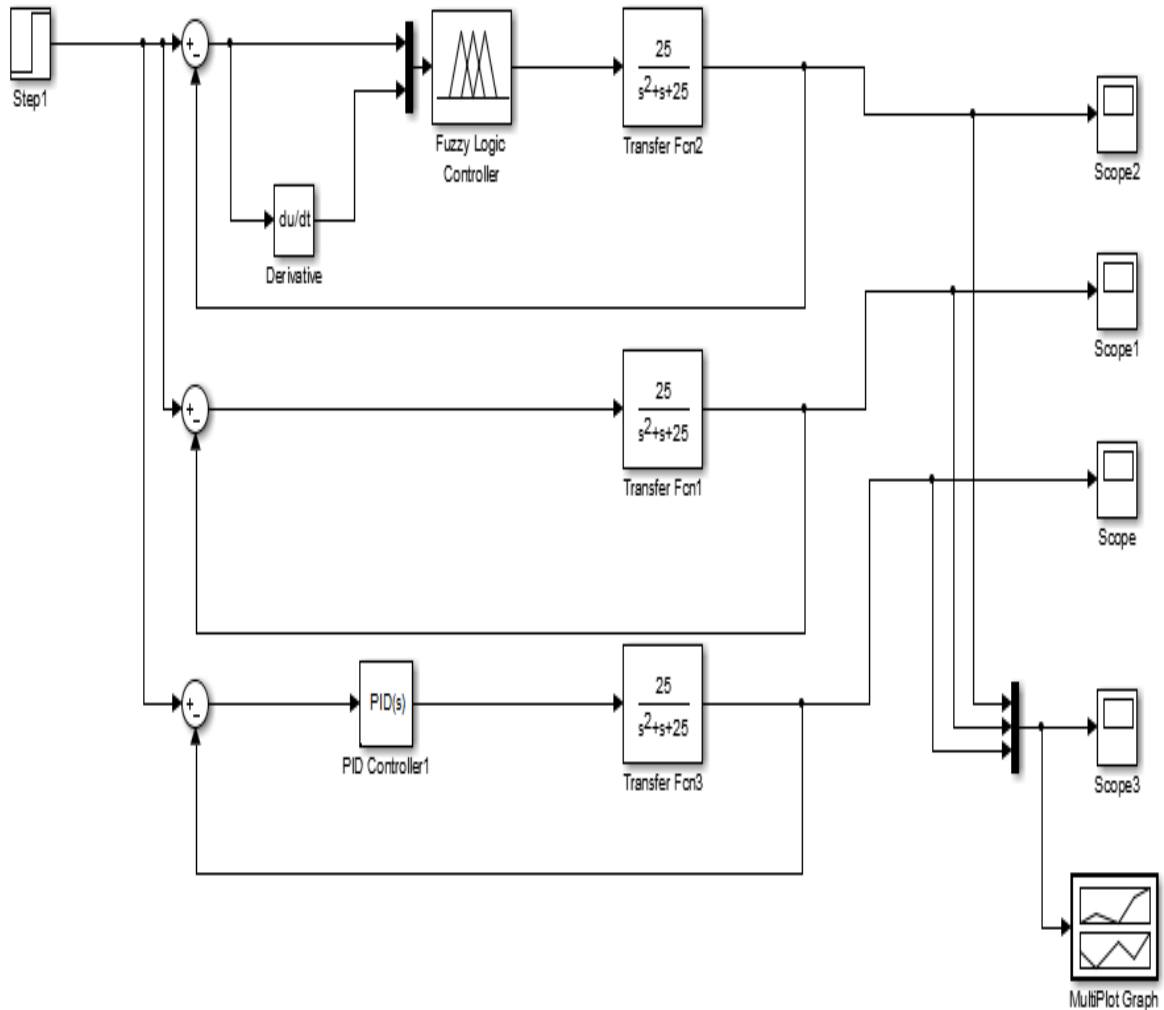
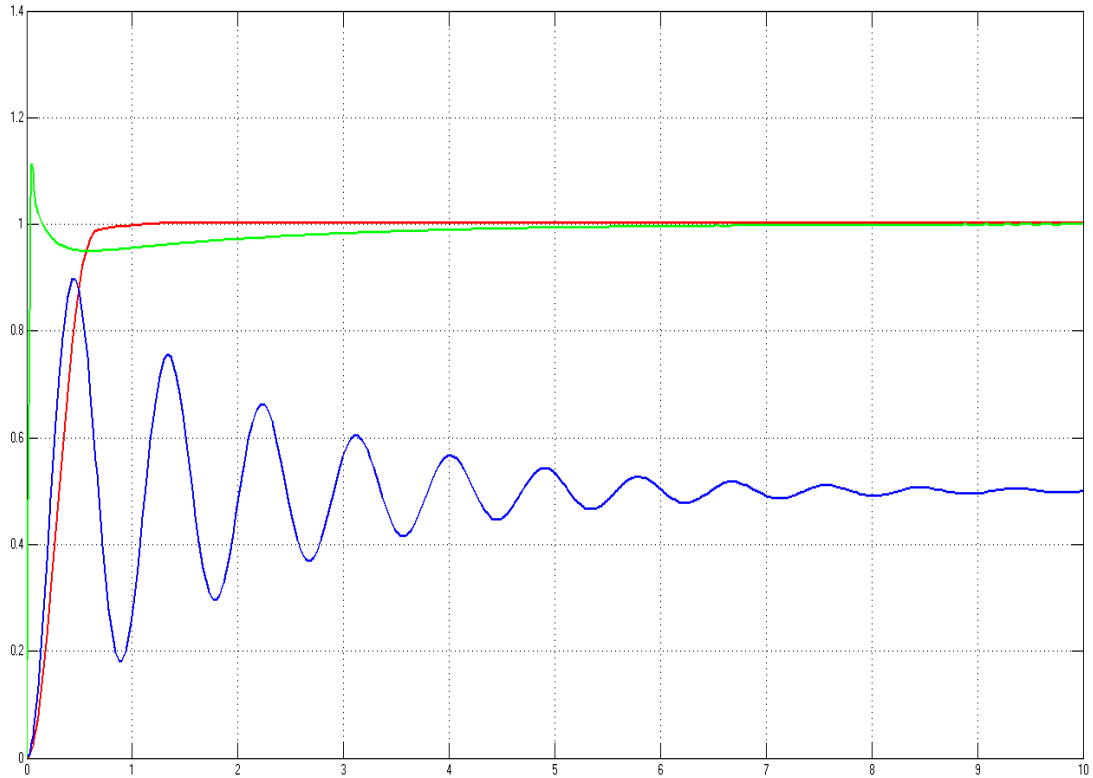

**Figure 5:** system without controller, the system with PID and the system with FLC

### 1. Result and discussion

When the program is run, the three scopes give the response shown in Figure (6)

In the present study; fuzzy logic is used for steam temperature control. For different set point of temperature the output of the controller gives satisfactory results. Also it is observed that the time required for fuzzy controller to reach the set point is very low. The FLC reaches the set point faster comparing with PID controller.



Without controller: —

FLC: —

PID: —

**Figure 6:** system response without controller and system with FLC and system with PID

The Table (4) shows Characteristics of the system response without controller and system with FLC and the system with PID.

**Table 4:** The response characteristics of the three systems

Characteristics	Without controller	With FLC	With PID
Settling time	7.65 sec	0.66 sec	4.25 sec
Rising time	0.156 sec	0.57 sec	0.0219 sec
Overshoot	80%	0.001%	11.4%
Peak amplitude	0.9	1.001	1.11
Final value	0.5	1	1

## 1. Conclusion and recommendations

In this paper the superheated steam is controlled using fuzzy logic and PID controllers. The simulation results are obtained using MATLAB/SIMULINK.

The fuzzy logic response is compared with the conventional PID controller. The results show that the overshoot, settling time, peak time and control performance has been improved greatly by using FLC. Better results may be obtained if Neuro-Fuzzy technique is used.

## References

- [1] <http://blog.opticontrols.com/archives/182>, date of access: June 2015.
- [2] LUO Wan jin. "Power plant thermal processes automatically adjust". China Electric Power Press. p. 168, 2004;
- [3] Jacques Smuts, "Improving Boiler Stability Through Advanced Regulatory Control " , OptiControls, Inc., Houston, Texas, 2010.
- [4] Zeyad Assi Obaid, Nasri Sulaiman, M. H. Marhaban and M. N. Hamidon, "Analysis and Performance Evaluation of PD-like Fuzzy Logic Controller Design Based on Matlab and FPGA", IAENG International Journal of Computer Science, 37:2, 2010.
- [5] A. Yasmine Begum, G.V.Venkata Marutheswar, K.Ayyappa Swamy, " Tuning of PID Controller for superheated Steam Temperature System using Modified Zeigler-Nichols Tuning Algorithm " , International Journal of Engineering and Advanced Technology, Volume-2, Issue-5, pp. 541-543, 2013.
- [6] Tomas Nahlovsky, "Optimization of Fuzzy Controller Parameters for the Temperature Control of Superheated Steam " , Elsevier Journal, pp. 1547 – 1555, 2015.
- [7] Pranita Chavan, " Superheated Steam Temperature control in Thermal Power Plant Using Fuzzy Logic Controller " , International Journal of Advance Foundation And Research In Science & Engineering, Volume 1, 2015.
- [8] <http://www.ccivalve.com/~media/files/c/cci/pdf/780-apr-total-system-attemperator.pdf>, date of access: June 2015.