



POLITECNICO DI TORINO  
Repository ISTITUZIONALE

Evolution of Wheelchair.q, a Stair-climbing Wheelchair

*Original*

Evolution of Wheelchair.q, a Stair-climbing Wheelchair / Quaglia, Giuseppe; Franco, Walter; Nisi, Matteo. - ELETTRONICO. - (2015). ((Intervento presentato al convegno The 14th IFToMM World Congress tenutosi a Taipei, Taiwan nel October 25-30, 2015.

*Availability:*

This version is available at: 11583/2657733 since: 2017-05-31T18:16:40Z

*Publisher:*

IFTToMM

*Published*

DOI:10.6567/IFTToMM.14TH.WC.OS13.032

*Terms of use:*

openAccess

This article is made available under terms and conditions as specified in the corresponding bibliographic description in the repository

*Publisher copyright*

(Article begins on next page)

## Evolution of Wheelchair.q, a Stair-climbing Wheelchair

G. Quaglia<sup>1</sup>  
Politecnico di Torino  
Torino, Italy

W.Franco<sup>2</sup>  
Politecnico di Torino  
Torino, Italy

M. Nisi<sup>3</sup>  
Politecnico di Torino  
Torino, Italy

**Abstract:** This paper presents a solution for a stair-climbing wheelchair that can climb single steps or entire staircases. This device was designed in order to ensure greater autonomy for people with reduced mobility. The main component of the wheelchair structure is a three-wheel locomotion unit that allows obstacle climbing thanks to an epicycloidal transmission. The other characteristic element is an idle track that behaves like a second foothold giving static stability during stair-climbing.

Another important feature concerned with this design is a reconfiguration mechanism that makes the wheelchair suitable both for stair-climbing and for moving on flat ground. This feature allows performances and overall dimensions comparable to traditional electric wheelchairs. The choice and design of the mechanisms for the reconfiguration phase are the main topics discussed in this article and represent the principal innovations of this wheelchair compared to earlier versions.

**Keywords:** Architectural barriers, Reconfiguration mechanism, Stair-climbing, Wheelchair.

### I. Introduction

Architectural barriers still represent a great reduction of autonomy for people that require a wheelchair for daily use. Often the problem is solved with accessibility adaptations where it is possible. In these cases, fixed or mobile stair lifts are a common solution. However, these require an additional device that may not be available everywhere. The authors, instead, propose a wheelchair that moves on flat ground and climbs obstacle using the same device. The requirements for the design could be summarized in:

- stair-climbing ability;
- usable both in structured and unstructured environment for daily mobility;
- ensure complete autonomy for the user;
- dimensions, weight and autonomy comparable to traditional electric wheelchairs;
- functional simplicity;
- simple structure.

Currently there are some stair-climbing wheelchairs available commercially, but they are usually too complex, heavy, cumbersome and expensive.

Various solutions have been researched to explore different types of locomotion. The most common solution, also among commercial products, is represented by track-wheel hybrid locomotion that uses wheels for moving on flat ground and tracks for stair climbing.

Some examples of this type of device are presented in [1] and [2]. The hybrid leg-wheel solution is another type of locomotion that uses two different devices for moving in complex environments. Examples of this kind of solution can be found in [3], [4], [5] and [6].

In general, wheel devices are light, compact and have a smaller energy consumption respect to track devices. For these reasons the authors have focused on the first kind of devices. In particular three versions of a stair climbing wheelchair concept called *Wheelchair.q* have been developed. All the design process has been oriented according to some preliminary choices:

- few degrees of freedom must be controlled;
- limited set of sensor must be required;
- limited number of command must be necessary.

These guidelines have affected the mechanical design and should guarantee to obtain better performances respect to current wheelchairs in terms of simplicity, cost reduction and autonomy. However the sensor system, the control logic and the complete mechatronic design are under construction and a full comparison is not already possible.

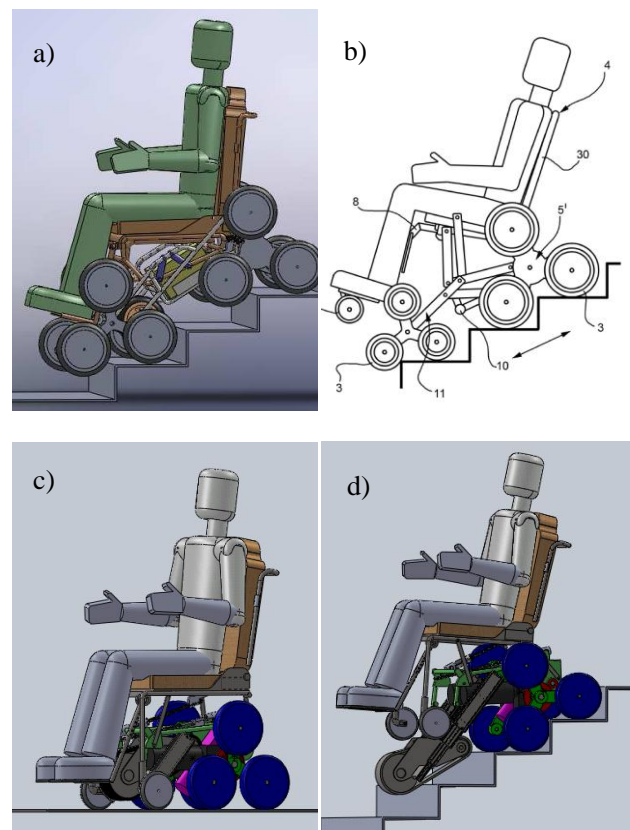

Fig.1 – Previous version of Wheelchair.q

<sup>1</sup> giuseppe.quaglia@polito.it

<sup>2</sup> walter.franco@polito.it

<sup>3</sup> matteo.nisi@polito.it

Early versions of *Wheelchair.q* proposed a structure with three-wheel locomotion units both for front and rear supports [7] (Fig.1, a), [8], [9] (Fig.1, b). In [10] a different approach is proposed. The solution described (Fig.1, c, d) is hybrid: a three-wheel locomotion unit is coupled with a track as front support. This hybrid solution seems to solve some critical issues of previous versions and for this reason it has been maintained also in the work presented in this paper. However, additional changes have been introduced with the aim of improving the performance of the wheelchair.

In this article, the global structure of the wheelchair is presented and the design requirements of the reconfiguration mechanism are defined. Then, the proposed solution is discussed analyzing advantages and disadvantages with respect to earlier proposals.

## II. Wheelchair description

From a functional point of view, the wheelchair structure is constituted by three elements as in the previous version:

- A. locomotion unit
- B. track
- C. seat

The relative positions between these elements depend on operating conditions as can be observed in Fig.2 and define the wheelchair behavior.

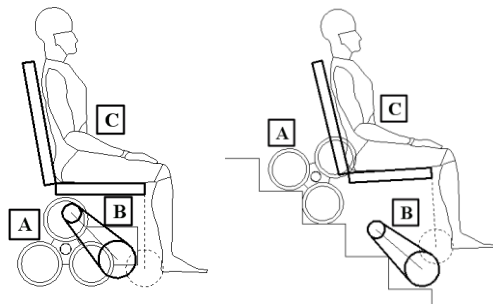

Fig.2 – Relative positions between functional elements during movement on flat ground (left) and during stair-climbing (right)

From a constructive point of view the structure is instead a bit different from the previous one, as shown in Fig.3.

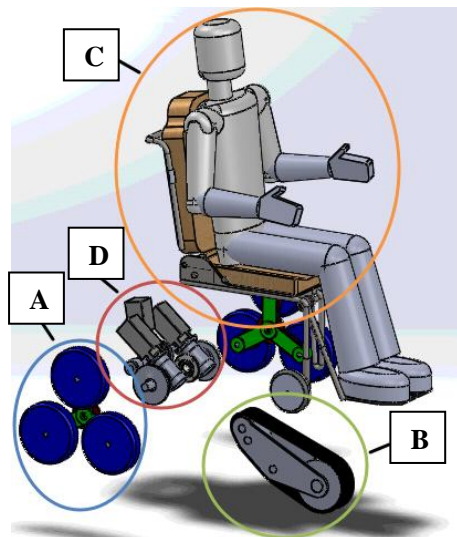

Fig.3 – Wheelchair constructive solution

The frame to which all the other elements were connected has been substituted by two reconfiguration mechanisms that connect one element to the other in a serial way. Besides the functional elements (A, B, C) the transmission group (element called D) has been added: it is composed of the locomotion motors and their transmission systems. The main functional characteristics of each wheelchair element are described in the following sections.

### A. Locomotion unit

The characteristic element of the wheelchair structure is the locomotion unit (Fig.4). It is composed of a triangular shaped frame with an internal epicycloidal mechanism that connects the input gear (solar) to each wheel linked to the planet gears.

The working principle was tested by the authors in several applications for mobile robotics and described in several papers [11], [12] and [13]. The gear ratio of the epicycloidal mechanism can be obtained by the Willis equation:

$$\frac{\omega_w - \Omega}{\omega_s - \Omega} = \frac{r_s}{r_{PG2}}$$

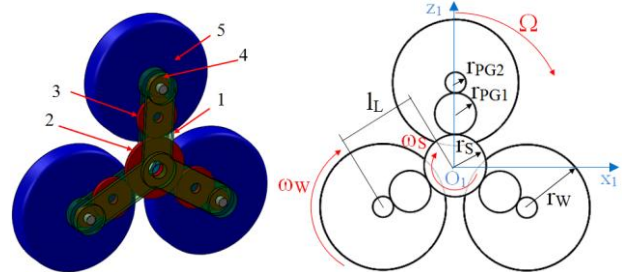

| Label | Component          | Angular rate   | Parameter | Value  |
|-------|--------------------|----------------|-----------|--------|
| 1     | Planet carrier     | $\Omega$       | $l_L$     | 160 mm |
| 2     | Solar gear         | $\omega_s$     | $r_s$     | 60 mm  |
| 3     | First planet gear  | $\omega_{PG1}$ | $r_{PG1}$ | 40 mm  |
| 4     | Second planet gear | $\omega_{PG2}$ | $r_{PG2}$ | 20 mm  |
| 5     | Wheel              | $\omega_w$     | $r_w$     | 120 mm |

Fig.4 – Constructive and schematic representation of the locomotion unit

### B. Track

The track is idle and acts as a second foothold for the wheelchair; it gives static stability and avoids overturning. Compared to previous works its shape has been modified, passing from a straight shape (red) to a curved shape (blue) as represented in Fig.5a e Fig 5b.

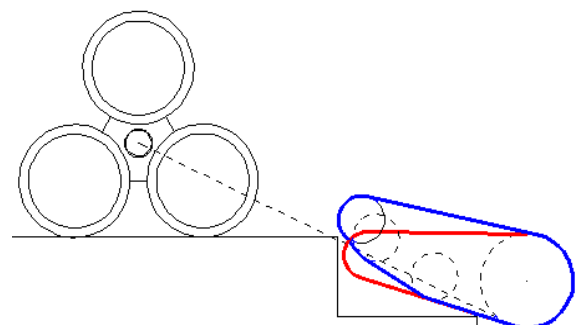

Fig.5a – Comparison between different track shapes

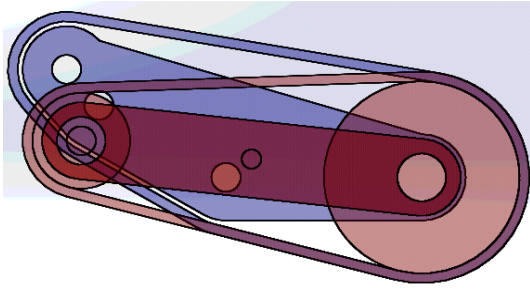

Fig.5b – Comparison between different track shapes

This makes easier the last step climbing by avoiding the contact between the last rise and the rear pulley.

### C. Seat

This element can be considered as a single rigid body or a further degree of freedom can be introduced between the seat and the frame where the other elements are connected. This affords more control over orientation and compensates the oscillations that occur during step climbing. In this work, however, it has been considered as a single body in order to reduce the number of actuators and the complexity of the structure.

### D. Transmission group

The transmission group is composed of three locomotion motors and their transmissions as in Fig.6.

As in previous versions, the two degrees of freedom of each locomotion group are controlled independently. Each solar motor ( $M_s$ ) is connected with the solar gear of the corresponding locomotion group, while the single planet carrier motor ( $M_p$ ) is linked to both planet carriers with a 1:3 transmission gear system that allows each shaft rotation to be coupled with a step ascent or descent ( $120^\circ$  of planet carrier revolution). The global architecture is however similar to the one described in [10].

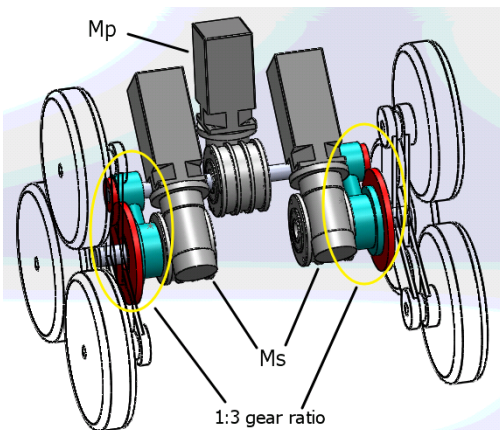

Fig.6 – Constructive solution for the transmission group

## III. Wheelchair reconfiguration

The wheelchair should be able to move both on structured flat ground and up and down stairs. These different situations need many sets of requirements.

On flat ground (Fig.7) the wheelchair has to be as compact as possible in order to extend the mobility inside structured environments and must move on wheels to reduce energy consumption.

However, during movements on stairs (Fig.8) the distance between supports must be large enough to avoid overturning. The front foothold should be on the track, the center of gravity has to be approached to the stair plane for safety reasons and the seat must be reoriented to avoid a forward tilt which could be dangerous for the user.

The relative positions between functional elements that guarantee the fulfillment of the requirements are completely different in the two situations. Thus it is necessary to introduce a mechanism that modifies the wheelchair structure before and after stair climbing.

In a previous work [9] the problem was addressed with two mechanisms that changed the position of the seat and the track with respect to a frame connected to the locomotion units and the transmission group. The seat and the frame were linked with a four bar linkage while for the track a linear guide was used.

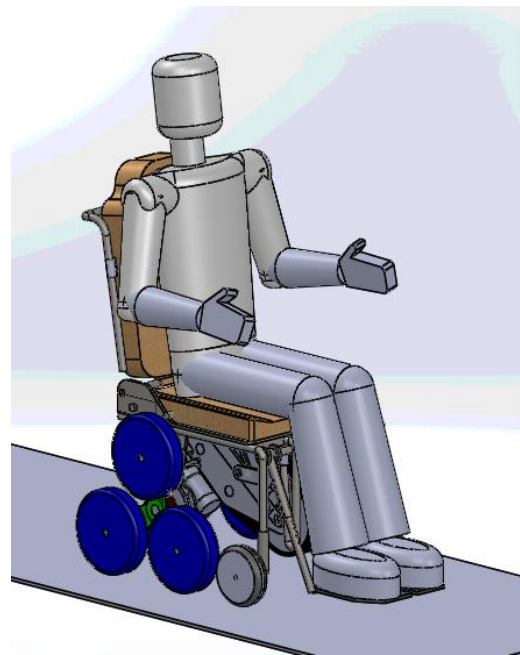

Fig.7 - Wheelchair configuration for flat ground movements

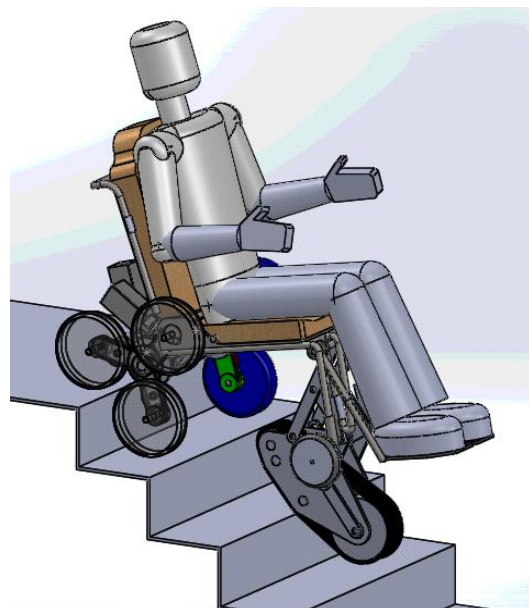

Fig.8 – Wheelchair configuration for stair-climbing movement

This kind of approach has two principal limitations:

- 1) constructive issues related to the long stroke required for the track guide;
- 2) interference problems between the seat and the frame when the seat reaches the lower position.

For these reasons a different mechanism has been developed and its design process will be discussed in the next paragraph.

#### IV. Reconfiguration mechanisms

In order to have a greater range of relative movements the frame has been removed and two mechanisms have been designed to control relative positions between:

- locomotion unit and seat;
- seat and track.

This solution lets to use two mechanisms each one with a lower displacement respect to the previous version where the guide manages the entire track stroke.

##### A. Locomotion unit-seat mechanism

The relative positions between the two elements have been considered with kinematic inversion, analyzing the movement of the locomotion unit respect to the seat. The starting position (in green on Fig.9) is the one that minimize the longitudinal dimension and at the same time grants enough stability and a proper height of the seat from ground. The reconfiguration mechanism should move the locomotion unit backwards and upwards, assuming the stair-climbing position (in red on Fig.9) in order to bring the user closer to the stair but avoiding interference.

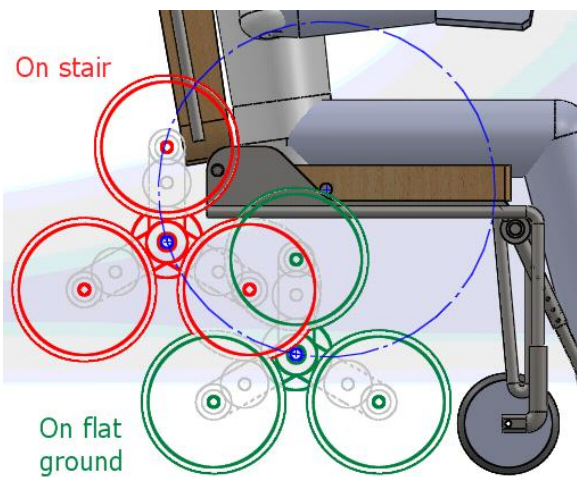

Fig.9 – Reference configurations for the locomotion unit-seat mechanism

With only two reference positions, an infinite number of mechanisms satisfies the requirements. The simplest solution that can be proposed is just a single bar that moves the center of the locomotion unit respect to the seat. In order to avoid interference between the seat and the transmission group, the final solution adopted is a four bar linkage that lets to move the locomotion unit in the desired position and at the same time rotates the motors group. Comparing Fig.10 and Fig.11 can be observed how this first step of reconfiguration contributes to move forwards and downwards the user center of mass.

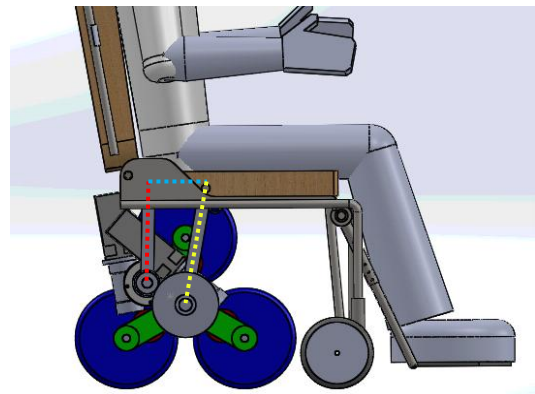

Fig.10 - Locomotion unit-seat mechanism in the flat ground configuration

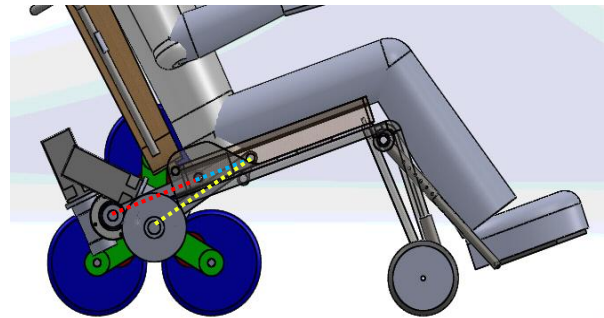

Fig.11 - Locomotion unit-seat mechanism in the stair-climbing configuration

##### B. Seat-track mechanism

The second mechanism manages the relative position between seat and track. As explained before, the track represents the second foothold besides the locomotion unit. Thus the wheelchair behavior during stair climbing depends on the relative position between these two elements.

For this reason the position of a generic track, independently from its shape, is described with the three parameter  $d, \gamma, \phi$  related to the locomotion unit reference frame (green in Fig.12) or with the parameter  $d', \gamma', \phi'$  related to the seat reference frame (red in Fig.12).

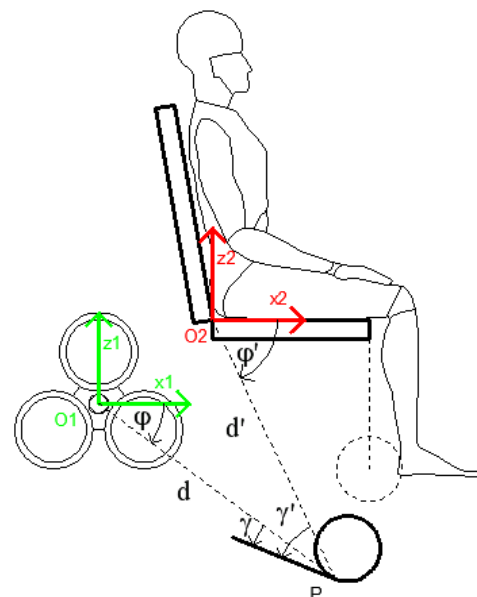

Fig.12 – Description of the generic relative position between the track, the seat and the locomotion unit

During movements on flat ground the track should be completely under the seat in order to avoid possible contact with external elements or with the ground. Thus this relative position has been obtained trying to avoid interference and it is represented in Fig.13.

The values of the three parameters that describe the track position related to this configuration are:

$$d = 246 \text{ mm}, \quad \gamma = +5^\circ, \quad \varphi = 23^\circ.$$

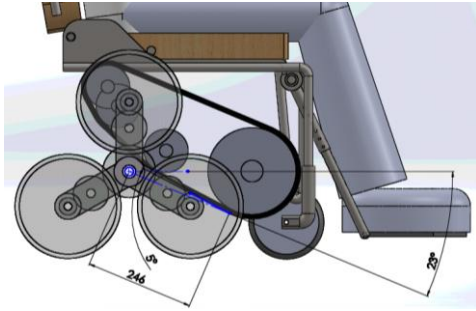

Fig.13 – Description of the track configuration during movements on flat ground

The extended position of the track during stair climbing affects the behavior of wheelchair during ascent or descent. In particular two aspects must be controlled: oscillations and overturning.

The trajectory of the locomotion unit is close to a cycloidal trajectory and thus generate oscillations of the seat during step climbing that could be uncomfortable for the user. The track extended position must be chosen in order to compensate and limit this issue. In a previous work [10] this aspect was analyzed and the results were collected in a graph (Fig.14) that shows the values of estimated oscillations  $\Delta\alpha$  as a function of parameters  $d$  and  $\gamma$ .

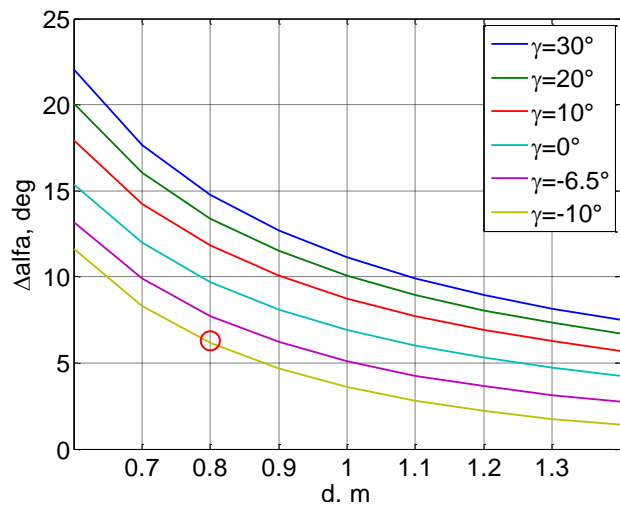

Fig.14 – Trend of seat oscillations during stair-climbing

A good compromise between the reduction of oscillations and the limitation of overall dimensions can be obtained with values:

$$d = 800 \text{ mm} \quad \text{and} \quad \gamma = -10^\circ$$

This configuration corresponds to specific values of parameters  $d'$  and  $\gamma'$  calculated with the locomotion unit

reference frame in the stair-climbing configuration. In particular can be measured:

$$d' \simeq 862 \text{ mm} \quad \text{and} \quad \gamma' \simeq -19^\circ$$

These values will be used to define the relative positions between seat and track for the design of the reconfiguration mechanism.

Furthermore, the track position must guarantees that the seat remain at least horizontal in order to avoid user overturning. The value of  $\varphi$  that satisfies this requirements can be obtained analyzing Fig.15 and is equal to  $\alpha_{MAX} + \alpha_S$ , where  $\alpha_{MAX}$  is the maximum inclination of wheelchair during step climbing and  $\alpha_S$  is the stair slope.

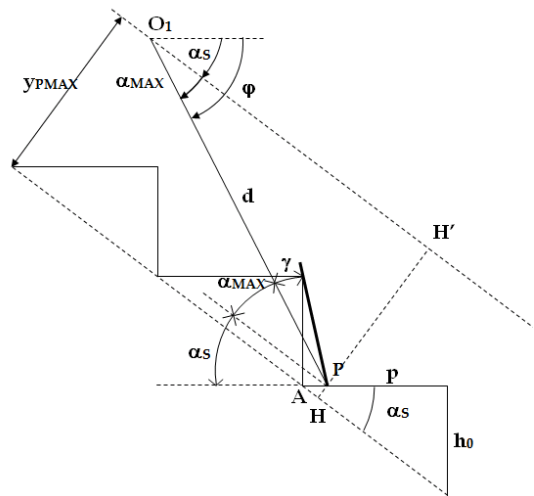

Fig.15 – Representation of the wheelchair in the boundary condition to avoid user overturning

The worst working condition for project specifications corresponds to a step with dimensions  $h_0=190 \text{ mm}$  and  $p=250 \text{ mm}$  ( $\alpha_S = 37,2^\circ$ ). In this configuration  $\varphi$  should be  $55^\circ$  and the corresponding  $\varphi'$  measured in stair-climbing configuration is about  $64^\circ$ . In conclusion the position of track during stair climbing is shown in Fig.16.

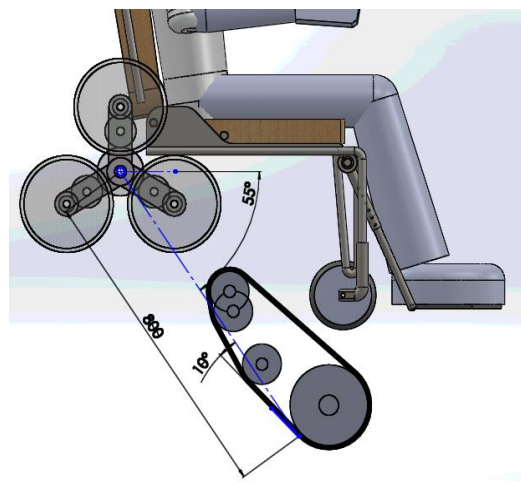

Fig.16 - Description of the track configuration during stair-climbing

The two configurations described previously have been summed up in Fig.17 where the positions of the track are referred to the seat.

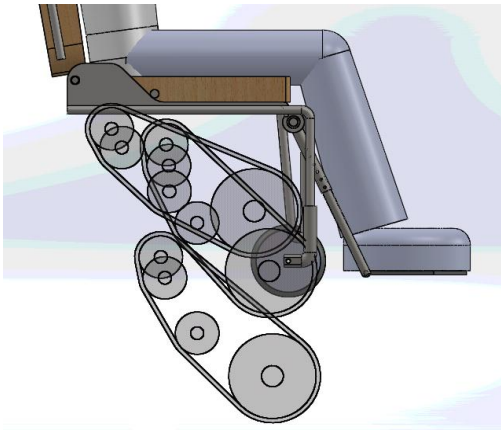

Fig.17 – Comparison between the different track configurations

In addition to the ones described above, a third configuration was added. This should be assumed by the track during the inlet and outlet phases. In these situations the wheelchair size must be reduced and the track orientation should be compatible with the first step descent.

Once the relative positions between track and seat are defined, a mechanism able to move the track between these reference configurations can be designed, trying to minimize the overall envelope.

Different types of mechanisms able to move the track between the three positions were proposed and designed with a recursive process. Their mechanical performances were analyzed and evaluated considering interference problems and difficulties in the constructive realization. For example since the front pulley needs to move on an almost straight trajectory, the use of a linear guide has been proposed but the stroke necessary would be too high compared to the length at rest condition.

Finally the proposed solution is the one showed in Fig.18. An amplifier mechanism with a multiplication factor of 2 has been applied to a short linear guide in order to obtain the movement required without problems connected to the stroke length.

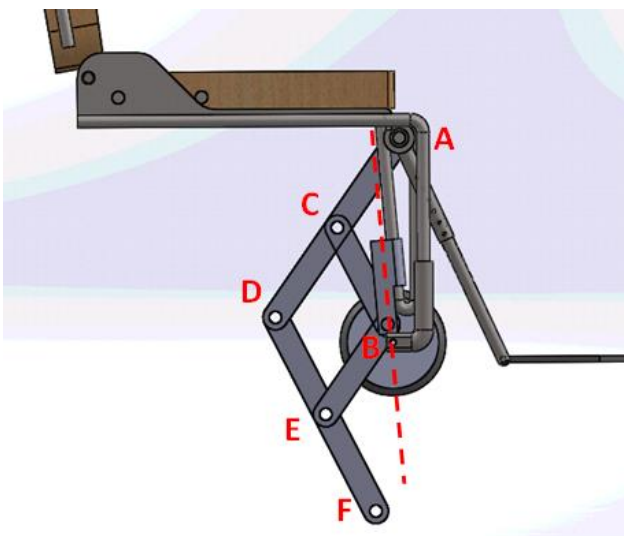

Fig.18 – Constructive representation of the proposed mechanism

In Fig.19 a schematization of the mechanism is represented.

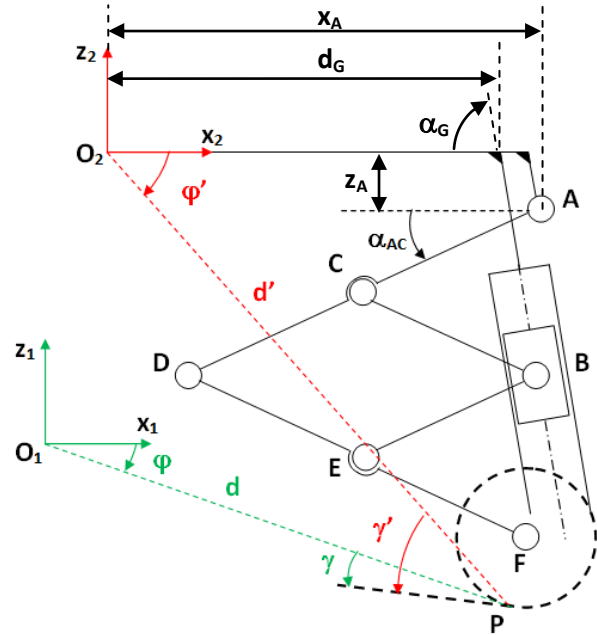

Fig.19 – Schematic representation of the proposed mechanism

Point 'A' represents the hinge connected to the seat while 'B' is the point linked to the linear guide fixed on the seat. The other bars are necessary to amplify the movement of 'F' connected with the track that will move on a straight line parallel to the guide axis. In Fig.20 generic initial and final configurations are represented and the input angle  $\alpha_{AC}$  is indicated in both situation.

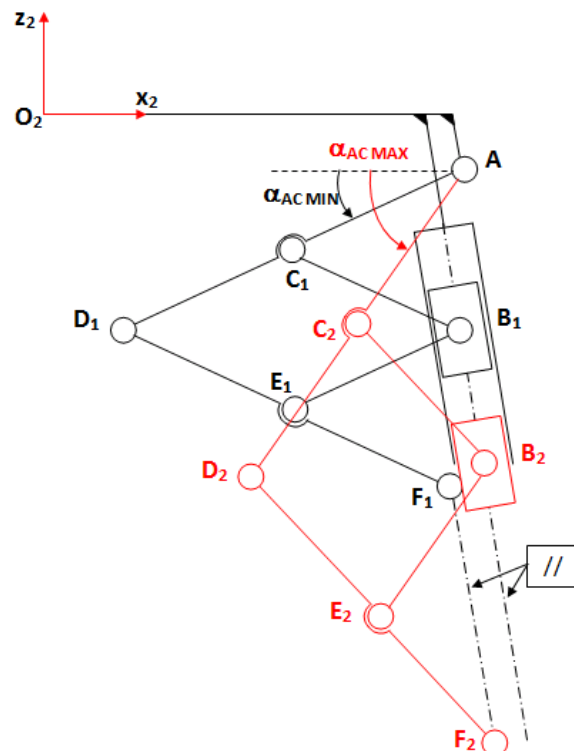

Fig.20 – Representation of generic initial and final configurations of the mechanism

The mechanism movement can be described using as input parameter the dimensionless angle

$$\mu = \frac{\alpha_{AC} - \alpha_{AC MIN}}{\alpha_{AC MAX} - \alpha_{AC MIN}}$$

where  $\alpha_{AC}$  is the value of the angle in a generic mechanism configuration. In this way the mechanism stroke corresponds to a variation of input parameter  $\mu$  from 0 to 1 independently from the specific values of  $\alpha_{ACMIN}$  e  $\alpha_{ACMAX}$ .

The solution described above is only the first part of the overall mechanism that manages the track position. It is necessary to add a second mechanism that modifies properly its orientation. The solution adopted consists of a pin mounted on the bar CB coupled with a circular groove made on track frame. In this way the movement of 'B' along the guide generates synchronous displacement and rotation of track. The complete mechanism is shown in Fig.21 in the three reference configurations.

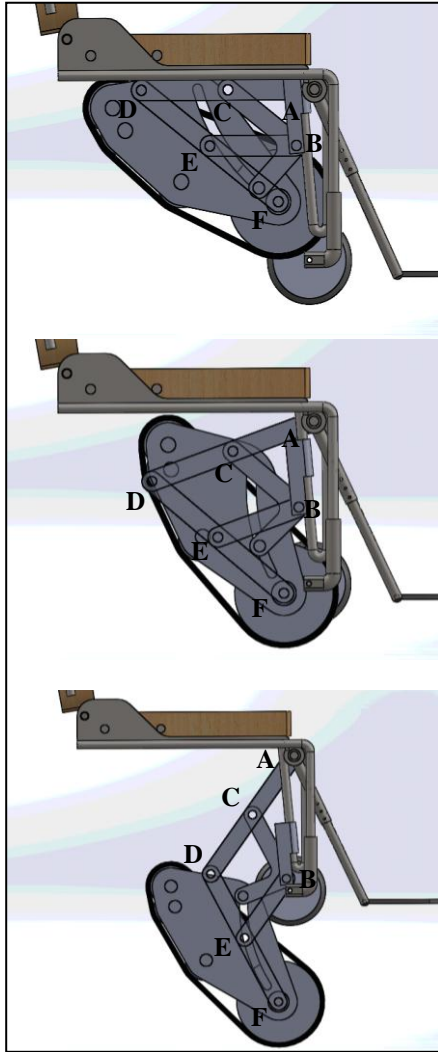

Fig.21 – Representation of the complete mechanism in three reference configurations

The value of the free parameters of the mechanism (link dimensions and position of fixed joints) have been chosen with a recursive process until the achievement of the solution that guarantees a correct track movement with the minimum envelope. The values are collected in Tab.1.

Then the designed mechanism has been analyzed from a kinematic point of view in order to evaluate the track movement during its outward stroke.

In Fig.22, Fig.23 and Fig.24 the values of parameters  $d$ ,  $d'$ ,  $\varphi$ ,  $\varphi'$ ,  $\gamma$ ,  $\gamma'$  (defined in Fig. 12 and 19) are shown as a function of the parameter  $\mu$  and can be observed how the

designed mechanism is able to reach the desired track position.

Tab.1 – Mechanism parameters of the seat-track mechanism

| Parameter                     | Value              |
|-------------------------------|--------------------|
| $d_G$                         | 465 mm             |
| $\alpha_G$                    | $85^\circ$         |
| $AD = DF$                     | 350 mm             |
| $AC = CD = DE = EF = CB = BE$ | 175 mm             |
| $\alpha_{ACMIN}$              | $0^\circ$          |
| $\alpha_{ACMAX}$              | $55^\circ$         |
| $[x_A, z_A]$                  | [500 mm , -100 mm] |

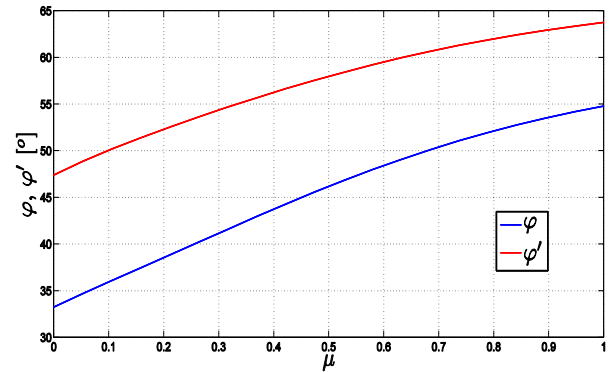

Fig.22 – Trend of parameters  $\varphi$  and  $\varphi'$

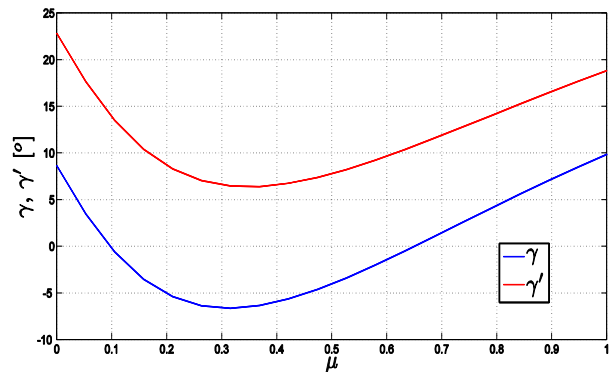

Fig.23 - Trend of parameters  $\gamma$  and  $\gamma'$

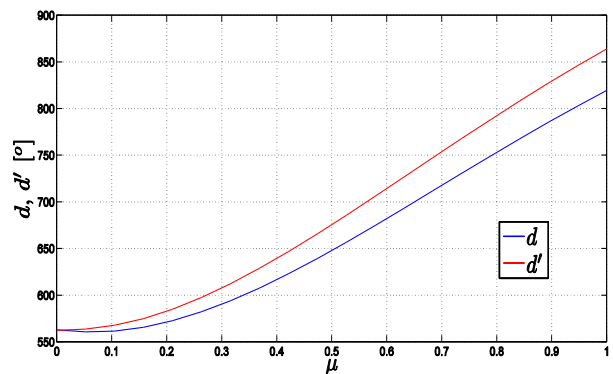

Fig.24 - Trend of parameters  $d$  and  $d'$

Finally an actuation system for the mechanism has been introduced. An optimization procedure has been done in order to minimize the force necessary during the wheelchair reconfiguration. The detailed procedure will be described in the next paragraph.



### C. Actuation

This section concerns a simplified analysis and design of a possible actuation system for the track mechanism. The generic actuator is connected between point FA1, which belongs to the seat, and point FA2 that is linked to a member of the track mechanism as showed in Fig.25.

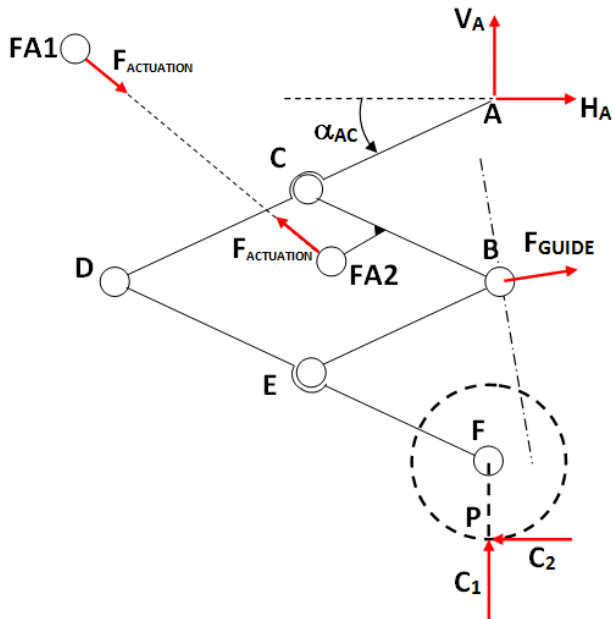

Fig.25 – Schematic representation of the free body diagram considered for this analysis

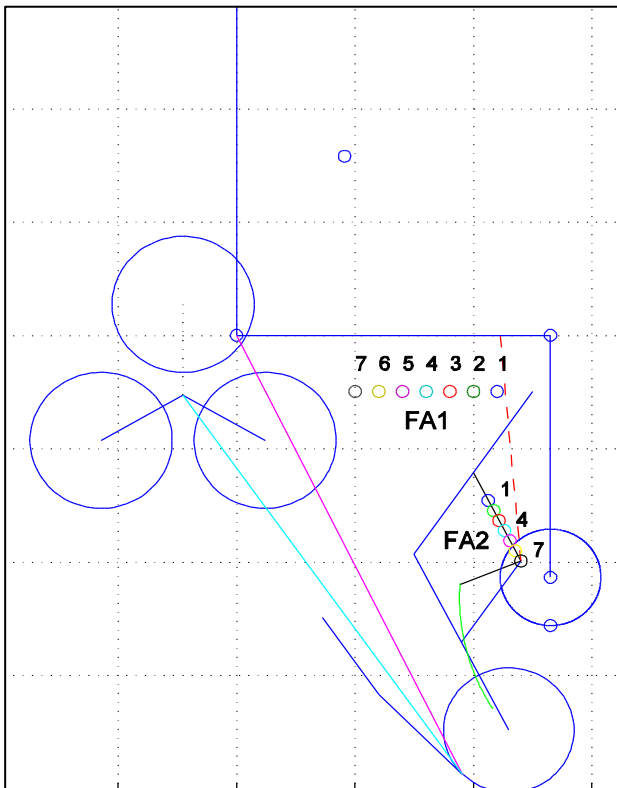

Fig.26 – Representation of the considered geometry during the first try (FA2 points on CB)

This first analysis has been done to evaluate which actuation system requires the lowest actuation force to complete the track outward stroke. The analysis has been

simplified fixing some free parameters. For example points FA2 have been chosen only on bar axis and moreover only on bar AD and CB because otherwise the resulting actuation system will be difficult to implement. Finally the analysis has been done in the worst loading condition, considering a force of 1000N (that corresponds to half of the wheelchair and user weight) applied on the front pulley and with a constant direction perpendicular to the seat plane. This means:

$$C_1 = 1000 \text{ N and } C_2 = 0 \text{ N } \forall \mu$$

The first try has been done considering FA2 points on CB bar as in Fig.26.

The actuator has been connected to each possible couple of points and for each combination the mean value of actuation force during the mechanism stroke has been computed. The results obtained are in Fig.27.

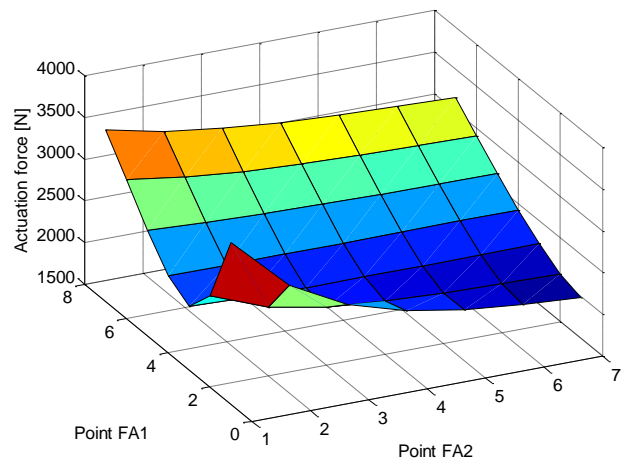

Fig.27 – Mean values of the actuation force required for each couple of points FA1 and FA2 (FA2 points on CB)

The lowest mean force is obtained with FA1 in 1 and FA2 in 7. In these condition the trend of the force during track movement is represented in Fig.28 and it is compatible with the hypothesis and with the load applied.

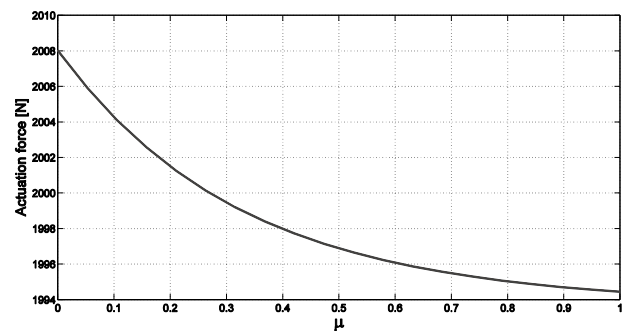

Fig.28 – Trend of the actuation force with FA1 in 1 and FA2 in 7 (FA2 points on CB)

The force remains almost constant with a module approximately double respect to the load as a drawback of the displacement amplification. The application of the actuation force on bar CB doesn't seem to be a good solution except for its particular case where the actuator is connected in B and the force acts parallel to the guide. In

this case, for the imposed load conditions, the required force remains constant for all the reconfiguration movement.

More interesting solutions can be obtained coupling points as represented in Fig.29. Points FA1 belong to the seat while points FA2 are along the bar AD. The mean force necessary to actuate the mechanism has been evaluated for each couple of points and the results are collected in Fig.30.

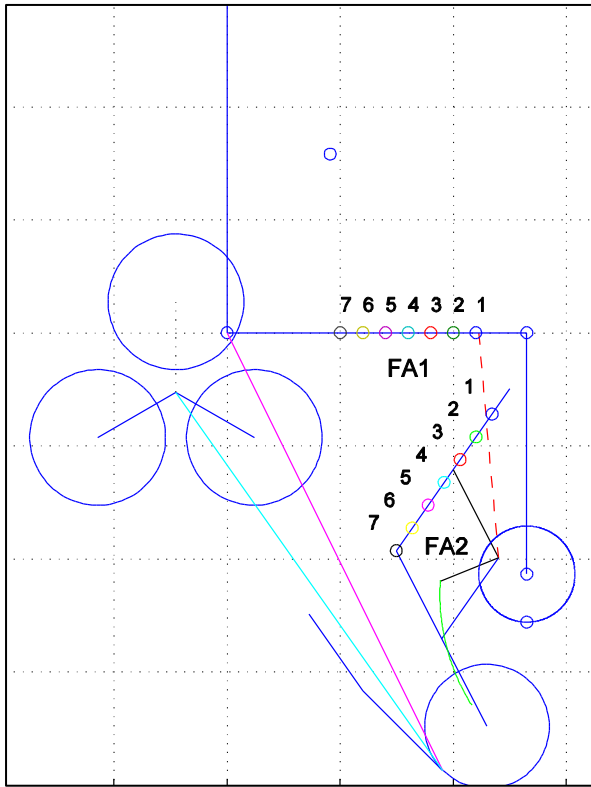

Fig.29 – Representation of the considered geometry during the second try (FA2 points on AD)

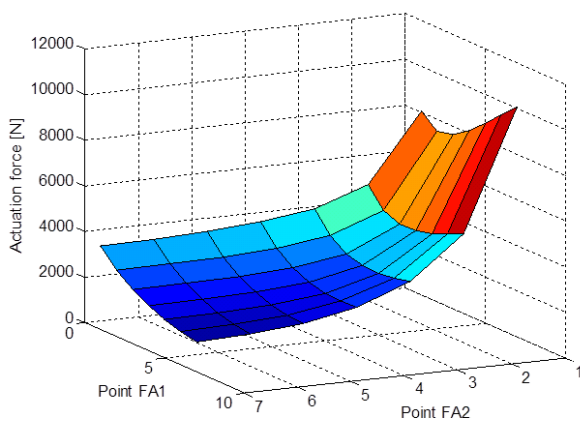

Fig.30 – Mean values of the actuation force required for each couple of points FA1 and FA2 (FA2 points on AD)

It can be observed that the lowest values are obtained with the couple of points FA1=7 and FA2=7.

In this case the trend of actuation force during the mechanism stroke is showed in Fig.31 and can be noticed that lower values are required respect to previous solution.

However this solution can't be accepted due to constructive aspects. Comparing the initial and final positions of the mechanism can be calculated that it is necessary a stroke of about 287 mm with an actuator length at rest condition of 111 mm. This values can' be obtained with commercial actuators.

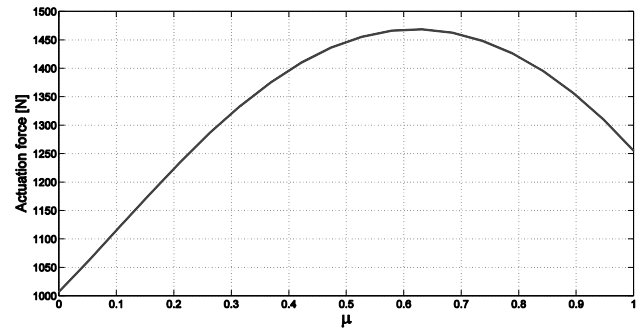

Fig.31 – Trend of the actuation force with FA1 in 7 and FA2 in 7 (FA2 points on AD)

A better solution is the one represented in Fig.32 and Fig.33.

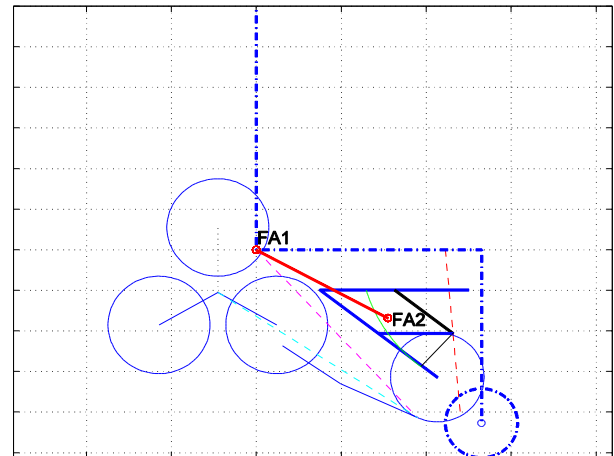

Fig.32 – Final mechanism represented in the initial configuration

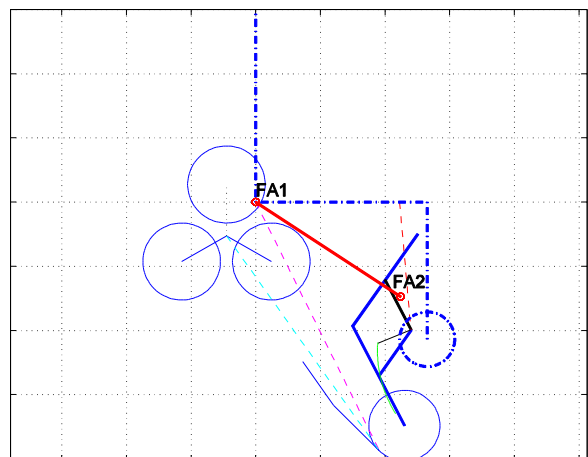

Fig.33 - Final mechanism represented in the final configuration

The results obtained in previous analysis have been extended evaluating a greater number of points and removing the hypothesis of choosing FA2 only along the AD bar axis.

Analyzing the trend of the actuation force in this case (Fig.34) can be observed that higher values are required compared to the previous one. Despite of this the stroke required is about 183 mm with a length at rest condition of 352 mm. These values are compatible with commercial actuators and thus this solution has been preferred.

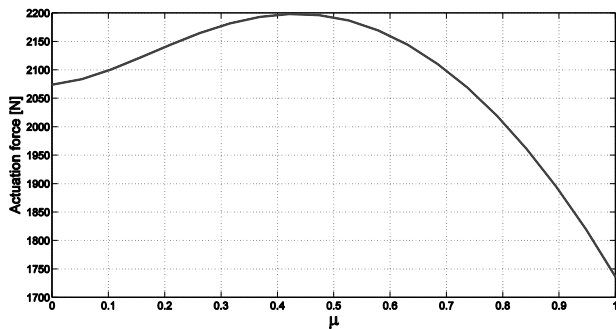

Fig.34 - Trend of the actuation force for the final mechanism

Finally in Fig.35 a constructive solution is represented. In particular the full mechanism and the actuation system chosen can be observed.

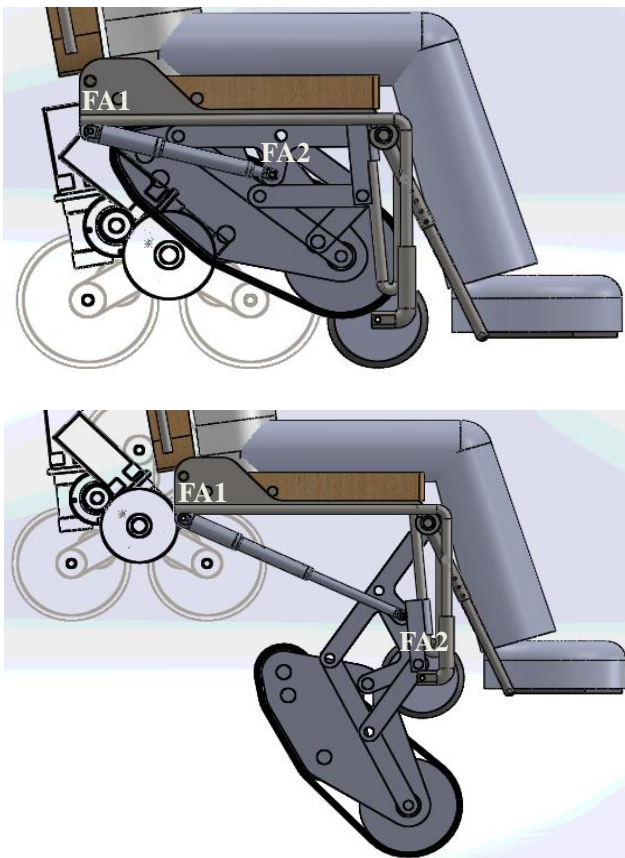

Fig. 35 – Constructive solution for the mechanism and the actuation system chosen in the initial and final conditions

## V. Conclusions

The solution proposed in this paper represents an evolution toward a stair-climbing wheelchair able to move with complete autonomy both on flat surface and staircase. In particular some critical aspects highlighted in previous works have been solved thanks to a redesign process of the

wheelchair reconfiguration. For example in this version of Wheelchair.q the center of mass is lower and the stability of the device has been improved. Moreover some constructive issues have been solved thanks to a more accurate design of the mechanisms that are necessary to change the relative positions between elements.

Next steps of the project will concern a dynamic analysis of wheelchair during different working conditions in order to evaluate if its behavior will be compatible with design requirements. Finally a sensing system and a control logic must be designed in order to complete the structure and allow the building of a working prototype with which the wheelchair behavior can be tested.

## Acknowledgments

The project was developed with the collaboration of Carmec S.r.l. company.

## References

- [1] Robert T. Quigg, "Stair-climbing wheelchair", Patent US 6857490, Feb. 22, 2005. Quigg, Robert. (2002).
- [2] Suyang Yu, Ting Wang, Xiaofan Li, Chen Yao, Zhong Wang and Di Zhi, 2010, "Configuration and Tip-Over Stability Analysis for Stair-Climbing of a New-Style Wheelchair Robot", International Conference on Mechatronics and Automation, Xi'an, China, pp. 1387-1392.
- [3] Morales R., Feliu V., González A. and Pintado P., 2006, "Coordinated Motion of a New Staircase Climbing Wheelchair with Increased Passenger Comfort", International Conference on Robotics and Automation, Orlando, Florida, pp. 3995-4001.
- [4] Sugahara Y., Yonezawa N. and Kosuge K., 2010, "A Novel Stair-Climbing Wheelchair with Transformable Wheeled Four-Bar Linkages", International Conference on Intelligent Robots and Systems, Taipei, Taiwan, pp. 3333-3339.
- [5] Murray J. Lawn, Ishimatsu T., 2003, "Modeling of a stair-climbing wheelchair mechanism with high single-step capability", Transactions on neural systems and rehabilitation engineering, 11(3), pp. 323-332.
- [6] Yuan J. and Hirose S., 2004, "Research on leg-wheel hybrid stair-climbing robot, Zero Carrier", International Conference on Robotics and Biomimetics, Shenyang, China, pp. 654-659.
- [7] Quaglia G., Franco W., Oderio R., 2009, "Wheelchair.q, a mechanical concept for a stair climbing wheelchair", International Conference on Robotics and Biomimetics, Guilin, China, pp. 800-805.
- [8] Quaglia G., Franco W., Oderio R., 2011, "Wheelchair.q, a motorized wheelchair with stair climbing ability", Mechanism and Machine Theory, 46(11), pp. 1601-1609.
- [9] Quaglia G., Franco W., Oderio R., "Carrozina ad assetto variabile per disabili", patent application n° TO2010A000863, 27/10/2010, Patent N. 0001402989
- [10] Quaglia G., Franco W., Nisi M., 2014, "Design of a Reconfiguration Mechanism for an electric Stair-climbing Wheelchair", International Mechanical Engineering Congress & Exposition, Montreal, Canada.
- [11] Quaglia G., Bruzzone L., Bozzini G., Oderio R. and Razzoli R. P., 2011, "Epi.q-TG: mobile robot for surveillance", Industrial Robot: An International Journal, 38(3), pp. 282-291.
- [12] Quaglia G., Maffiodo D., Franco W., Appendino S., Oderio R., 2010, "The Epi.q-1 Hybrid Mobile Robot", The International Journal of Robotics Research, 29(1), pp. 81-91.
- [13] Quaglia G., Bruzzone L., Oderio R. and Razzoli R. P., 2011, "Epi.Q Mobile Robots Family", International Mechanical Engineering Congress & Exposition, Denver, USA.