



POLITECNICO DI TORINO
Repository ISTITUZIONALE

Integrated miniaturized antennas for automotive applications

Original

Integrated miniaturized antennas for automotive applications / Vietti G.; Dassano G.; Orefice M.. - (2010), pp. 1-4.
((Intervento presentato al convegno Antennas and Propagation (EuCAP), 2010 Proceedings of the Fourth European Conference on tenutosi a Barcelona (SPAIN) nel 12-16 April 2010.

Availability:

This version is available at: 11583/2373875 since:

Publisher:

IEEE

Published

DOI:

Terms of use:

openAccess

This article is made available under terms and conditions as specified in the corresponding bibliographic description in the repository

Publisher copyright

(Article begins on next page)

Integrated miniaturized antennas for automotive applications

G. Vietti*, G. Dassano*, M. Orefice*

* *Dipartimento di Elettronica – LACE, Politecnico di Torino*

C.so Duca degli Abruzzi, 24. Torino, Italy

{guillermo.vietti, gianluca.dassano, mario.orefice}@polito.it

Abstract— Two miniaturized antennas, working at 2.44 GHz (ISM band) and 4.5 GHz (for UWB signals) with 11% bandwidth, have been integrated into and around a cubic sensor node of about 1 cm side used in automotive applications. The influence of the nearby metallic components has been reduced, and good performances and agreement between simulated and experimental results has been found.

I. INTRODUCTION

In recent years, the development of wireless systems in many fields of the ordinary life, not only related to communications systems but also to many other applications, like monitoring, safety, security, bioengineering, etc. has led to the requirement to have antennas with minimum dimensions, low cost, sometimes large bandwidth, and obviously a very low cost to be competitive in the marked and allow the systems to be affordable for the maximum number of users.

One of the most critical aspects of many of such systems is that the antennas are often not in a clear environment allowing an easy transmission and reception, but they are integrated in a (small) device containing metallic parts, e.g. sensors, which interact with the antenna, tending to modify (and strongly deteriorate) its characteristics because they interfere with the near field of the antenna, and consequently modify the impedance matching and the radiation pattern; moreover the device is on its turn mounted on, or inside, a generic “body” which usually is an electromagnetically disturbing structure, since it consists of dielectric or metallic parts, so that the such changes become more significant.

The frequencies used for such systems are chosen usually in the unlicensed bands, and must allow a relatively good propagation also in absorbing media, but at the same time they must have a relatively short wavelength not to require too large antennas or very narrow bandwidth: at UHF, some bands are available to this scope. However, if a larger bandwidth is required, at somewhat higher frequencies (e.g. 5 GHz) other bands are available. Consequently, the size of the antenna is often required to be much smaller than a wavelength (typically, around $\lambda/10$ or less).

In this application, an antenna system consisting of two miniaturized antennas, operating at 2.44 GHz (ISM band) and 4.5 GHz (for UWB signals) are required, to be integrated into and around a cubic sensor node of about 1 cm side, to be used in automotive applications. The node contains the transmit and receive electronics, sensors, power source, so that it has a

number of metallic parts interfering with the antennas near field. For mechanical reasons the top and bottom sides of the cube must be left empty, so these surfaces are unusable for the antennas.

The major requirements and constraints for the UWB system antenna are a bandwidth of 11% around 4.5 GHz with a reflection coefficient less than -10dB, a balanced feed with 100 Ω input impedance, a radiation efficiency better than -6 dB; for the ISM system the specifications were a frequency band of 80 MHz with a reflection coefficient less than -10dB, unbalanced feed with 50 Ω of input impedance and high radiation efficiency.

The main problems in fulfilling such requirements are how to keep the antenna performance unchanged or improved, even though the antenna size becomes small, and how to mitigate the degradation of the antenna performance due to the metallic elements of the adjacent sensor element.

II. GEOMETRY OF STRUCTURE

The perspective view of geometry of sensor node with antennas detail is shown in Figure 1.

In order to isolate the antennas from the influence of metallic elements placed into the cube, a thin, flexible, magnetically loaded dielectric sheet (gray area in fig.1) was placed in the inner sidewall of the cube (yellow cube), that operates as a shield and absorber in the range 2.-12. GHz, so that it includes both bands (ISM and UWB).

For the UWB antenna, a configuration derived from a thick folded dipole has been used, modified in a C shape as shown in fig.1 (red strips in the front of cube).

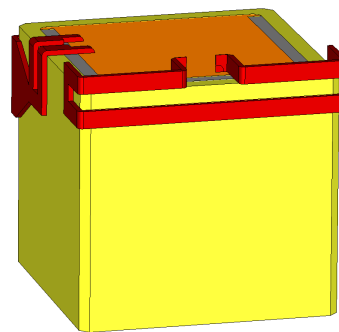

Fig. 1: Geometry of the antennas mounted on the sensor node.

This type of antenna, used by various authors (see e.g. [1]) with different arrangements, does not need a ground plane and has a balanced feed as required. However in this case, in order to integrate the antenna onto the cube, it has been necessary to fold its ends on the other sidewalls of the cube, increasing the capacitive effect.

The choice of the forded type of antenna is justified by its characteristics: essentially, a two strip folded dipole has an input impedance much higher with respect to a single wire dipole (theoretically, 4 times), and offers a good match to a balanced feed line with high impedance over a wide band. Here, the high antenna input impedance can compensate the effects of the nearby metals, which typically lead to a reduction of the impedance, tending to short circuiting the antenna. In addition, this shape can be easily integrated onto the box of the sensor, and it can be built in a small volume. The C shape (so that this antenna, being folded twice, could be called “*folded² dipole*”, or “*folded-square dipole*”) improves the radiation pattern by filling the nulls typical of the dipole along its axis, so ensuring a better pattern coverage in all directions. The antenna feed point is in the upper central part of one of the sidewalls of cube.

The antenna at 2.4-2.48 GHz is placed in the opposite side of the cube, and it is substantially a planar printed trapezoidal monopole. Planar monopole antennas have been considered and optimized by various authors (see e.g. [3], [4]) to provide extremely wide impedance bandwidths with good radiation characteristics: however they have too large dimensions for our purposes. Moreover, these antennas require some space around them, and a ground plane, in order to work correctly. Here, this monopole has an unbalanced feed with two microstrip lines, one connected to the ground plane of the printed circuit (actually, not a real ground plane because of its small size) and the other to the RF output. The strip of the monopole is folded around the box of the sensor node, and its radiating part is placed in the opposite sidewall from folded loop antenna, decreasing the coupling between them.

III. OUTCOMES

The behaviour of these antennas and their interaction have been simulated and optimized, and prototypes have been built and measured. For the impedance measurement, in order to measure the S parameters at the port of the balanced UWB antenna with a common Network Analyzer with coaxial cables (unbalanced connector), a microstrip balun (50 Ω unbalanced - 100 Ω balanced) was introduced, placed inside of the sensor node box.

Figure 2 shows the comparison between simulated (dashed lines) and measured (solid lines) scattering parameter magnitude vs. frequency for both antennas (port 1: ISM antenna, port 2: 4.5 GHz antenna).

This sensor will be placed in a space close to a material with characteristics similar to those of a relatively small metallic sheet. This slightly modifies the S parameters, as shown in fig.2. More significant is the influence on far field pattern.

In order to understand the behaviour of the sensor with the metallic sheet, far field patterns with and without it have been compared. The antennas node was placed and centred on a metallic plane of about 40 x 25 cm, with the longer side parallel to the main length of folded dipole and the normal pointed in z direction as shown in fig.3.

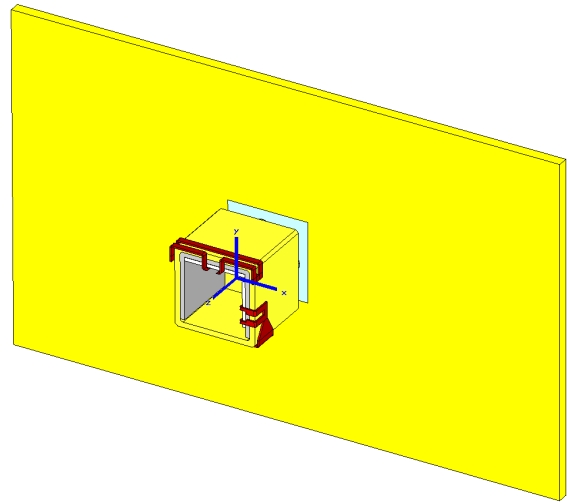

Fig.2: Geometry of sensor node with metallic plane (axes view)

The far field (FF) patterns in the principal planes are shown in Figure 4 and 5, for ISM and UWB antennas respectively.

Figure 6 to 9 show the 3D FF patterns and the orientation of electric field vector with small green arrows positioned on a spherical surface, for the two frequencies, and for the case with and without metallic plate.

IV. CONCLUSIONS

In this paper the design criteria, and the simulation and measurements results, for two miniaturized antennas, working at 2.44 GHz (ISM band) and 4.5 GHz (for UWB signals) have been shown. The antennas are onto a cubic sensor node of about 1 cm side, to be used in automotive applications. The influence of the nearby metallic components has been reduced and good performances and agreement between simulated and experimental results has been found.

ACKNOWLEDGMENT

This work has been partially supported by Piemonte Regional Government Funding for Industrial Research.

REFERENCES

- [1] H. Morishita, Y. Kim, Y. Koyanagi and K. Fujimoto, “A folded loop antenna system for handsets”, *2001 IEEE Antennas Propag. Symp.*, vol. 3, pp. 440-443, Jul. 2001.
- [2] J. A. Evans and M. J. Ammann, “Planar trapezoidal and pentagonal monopoles with impedance bandwidths in excess of 10:1,” in *Proc. IEEE Int. Symp. Antennas Propagation*, 1999, pp. 1558–1561.
- [3] Z. N. Chen, “Broadband roll monopole,” *IEEE Trans. Antennas Propag.*, vol. 51, no. 11, pp. 3175–3177, 2003.

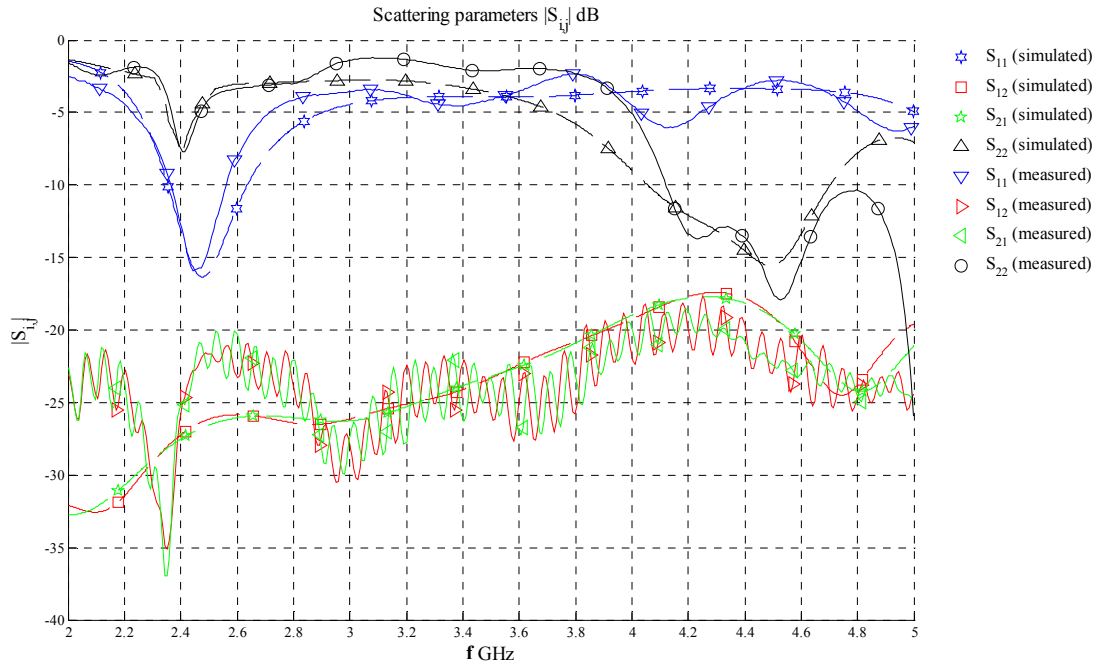

Fig.3: Scattering parameters magnitude ($|S_{ij}|$) in dB: simulated (dashed lines) and measured (solid lines) (port 1: ISM, port 2: UWB)

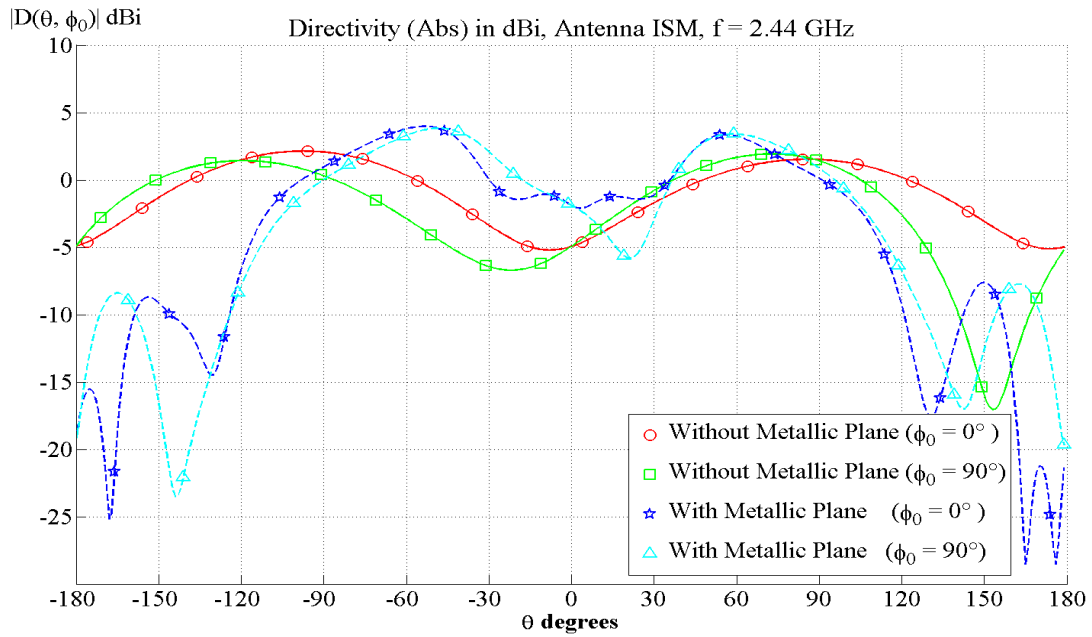

Fig.4: Directivity (Abs) cuts ($\phi = 0, 90^\circ$) of Antenna ISM at 2.44 GHz with (dashed lines) and without (solid lines) metallic plane. (dBi scale)

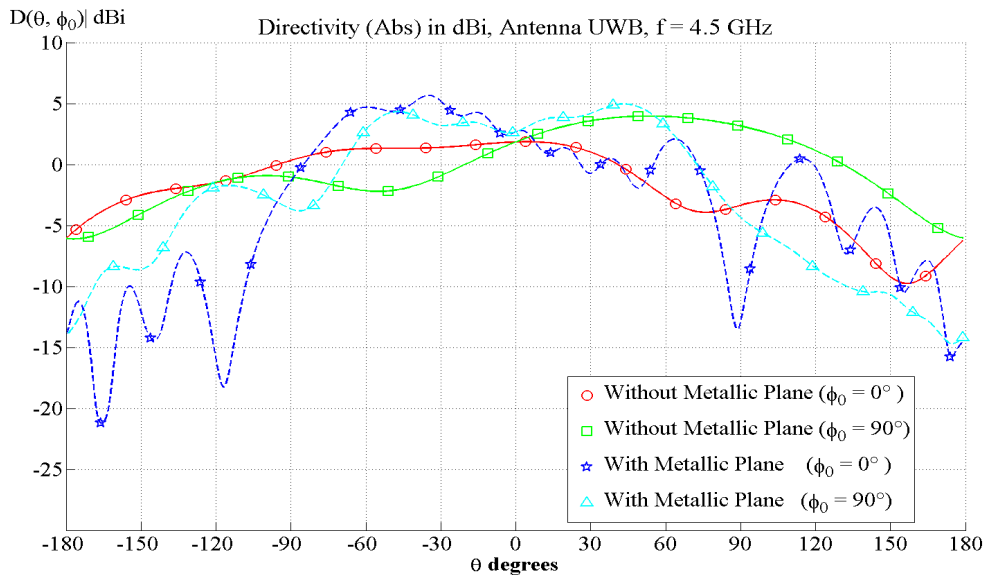

Fig.5: Directivity (Abs) cuts ($\phi = 0, 90^\circ$) of Antenna UWB at 4.5 GHz with (dashed lines) and without (solid lines) metallic plane. (dBi scale)

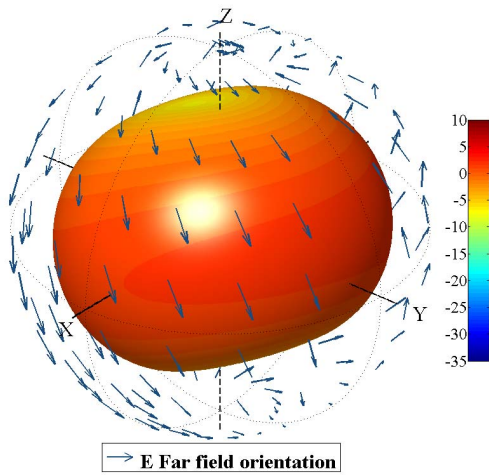

Fig.6: Directivity (Abs) 3d pattern of Antenna ISM at 2.44 GHz without metallic plane. (dBi scale) and E far field vector orientation.

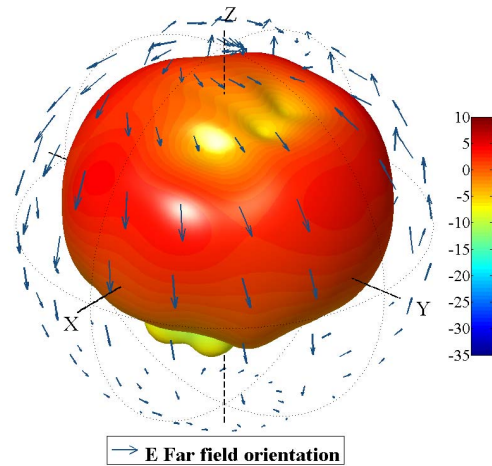

Fig.8: Directivity (Abs) 3d pattern of Antenna ISM at 2.44 GHz with metallic plane. (dBi scale) and E far field vector orientation.

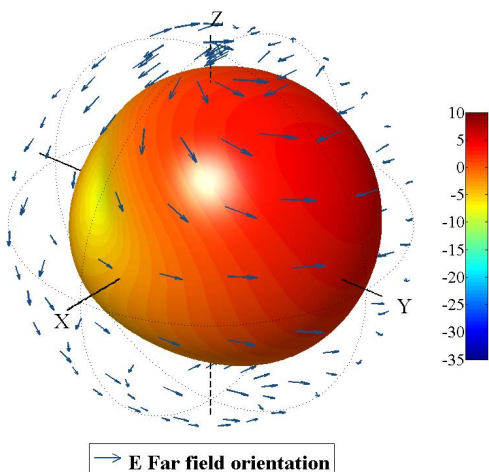

Fig.7: Directivity (Abs) 3d pattern of Antenna UWB at 4.5 GHz without metallic plane. (dBi scale) and E far field vector orientation.

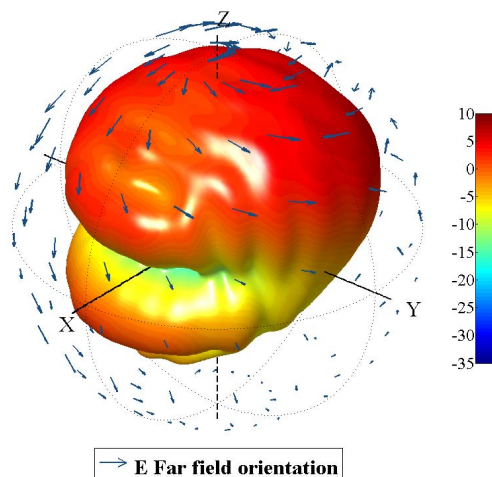

Fig.9: Directivity (Abs) 3d pattern of Antenna UWB at 4.5 GHz with metallic plane. (dBi scale) and E far field vector orientation.