



POLITECNICO DI TORINO
Repository ISTITUZIONALE

Integrated battery charger for electric scooter

Original

Integrated battery charger for electric scooter / ARMANDO E.G.; PELLEGRINO G.; GUGLIELMI P.. - STAMPA. - (2009), pp. 1-7. ((Intervento presentato al convegno EPE 2009, 13th European Conference on Power Electronics and Applications tenutosi a Barcelona (ESP) nel 8-10 Sept. 2009.

Availability:

This version is available at: 11583/2292739 since: 2017-11-03T00:34:47Z

Publisher:

EPE

Published

DOI:

Terms of use:

openAccess

This article is made available under terms and conditions as specified in the corresponding bibliographic description in the repository

Publisher copyright
taylor_francis_draft

-

(Article begins on next page)

Integrated Battery Charger for Electric Scooter.

Gianmario Pellegrino, Eric Armando and Paolo Guglielmi

Politecnico di Torino

C.so Duca degli Abruzzi 24, 10129

Torino, Italy

Phone: +39 (011) 090-7143

Fax: +39 (011) 090-7199

Email: (gianmario.pellegrino, eric.armando, paolo.guglielmi)@polito.it

URL: <http://www.delet.polito.it/>

Keywords

<<Electric vehicle>>, <<Battery charger>>, <<Power factor correction>>, <<Interleaved Converters>>.

Abstract

The paper deals with a battery charger integrated into the traction hardware of an electric scooter, for recharging the scooter batteries by means of a single-phase AC source. A mechanical switch and a rectifier bridge are the only additional components required to transform the electric scooter powertrain into a PFC battery charger, suitable for current-controlled or voltage-controlled recharge. The AC current is controlled at unitary power factor with no harmonic distortion. Switching harmonics are also drastically reduced by means of phase-interleaving. The battery charge is regulated according to the requests of the Battery Monitor System (BMS) that is embedded into the battery packs. The effectiveness of the integrated battery charger is demonstrated here on an electric scooter with high voltage Li-Ion battery (260V) and DC/DC/AC power conversion scheme. The integrated PFC charger concept is also valid for electric vehicles with AC traction drives based on a direct DC/AC conversion scheme, as demonstrated throughout the paper.

Introduction

Electric scooters are the up-to-date solution for zero-emission mobility in metropolitan areas: their diffusion has been growing in recent years. The traction battery is the most critical component on board of electric vehicles: the cost and weight of the vehicle as well as the driving range strongly depend on the battery size and technology. Battery charge is also a big issue: the expected lifetime of the battery set depends on the characteristics of the battery charger.

On-board chargers are appropriate for charging the battery with a limited power, that is supplied for example by the single-phase household utility outlet ($1 \div 3 \text{ kW}$). The battery charger is carried by the scooter, thus weight and volume must be minimized. The battery current and voltage must be controlled, according to the specifications of the manufacturer and to the battery state of charge. Last, the AC current absorbed by the distribution system must be conditioned according to the international standards [1], with unitary power factor and low harmonics distortion.

An on-board, integrated battery charger is proposed here, which uses the power conversion hardware of the electric scooter with very few additional components. The integral charger concept has been first proposed by [2], for an electric car with a thyristor-based inverter. The idea of using the common-mode inductance of an AC motor by means of a center-tap connection was first introduced in [3], for an electric car with 4 traction motors and 4 inverters. Dealing with electric scooters, a simpler conversion topology is proposed in [4], where the center tap of the traction motor is connected to a diode rectifier via a mechanical switch, and the traction inverter is operated as a single-phase dc-dc boost battery charger. The traction motor is an Induction Motor in that case. A similar topology is adopted here for a IPM motor traction drive, with the significant improvements of Power Factor Correction (PFC) control toward the utility mains and the phase interleaving of the inverter legs that strongly reduces the PWM ripple and improves the efficiency. Moreover, the case of DC/DC/AC electric powertrains is reported here, but the same concepts can be proposed for both the solutions (DC/DC/AC or DC/AC traction conversion schemes).

The electric scooter under test is a big urban scooter (7kW, 90km/h max), equipped with two Lithium-Ion battery packs (260V, 10Ah each) and a three-phase, IPM motor drive. Each battery is connected to the inverter dc-link by means of a DC/DC step-up stage. The scooter has been designed with particular attention to the efficiency and compactness of the power conversion stage [5]. The ratings of the electric scooter prototype are reported in the Appendix.

The paper is organized as follows. First, the power conversion structure of the electric scooter and the battery charger integration will be shortly described. Then, the phase interleaving principle, applied to multi-phase converters with coupled phases will be outlined [6] and extended to the specific case of a 3-phase motor used as the coupling inductor. The control algorithm will be also described. Experimental results demonstrate the feasibility of the proposed solution.

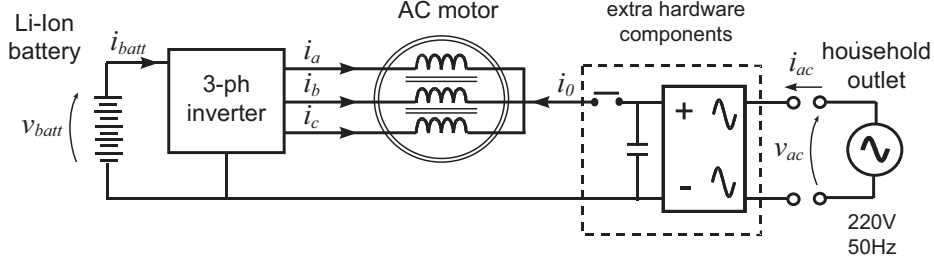

Figure 1: Integrated battery charger: the traction drive is transformed into a 3-phase boost rectifier.

PFC boost battery charger.

The power conversion scheme of the electric scooter is described in [7]. It is a DC/DC/AC structure with two identical Li-Ion battery packs managed by two bi-directional DC/DC stages, one per battery pack. In traction operation, the two DC/DC stages coordinately control the inverter dc-link voltage to a constant value (400V). Either in motoring, electric braking or recharge modes, the two battery packs are managed separately by the corresponding DC/DC converter and the battery current is supplied or absorbed according to the Battery Monitor System (BMS).

In recharge mode, the AC motor drive is operated as a 3-phase boost converter, as reported in Fig. 1, that can be controlled as a PFC rectifier. To concentrate the attention on the integrated PFC rectifier, the power structure has been represented in the figure is simplified and consists of a single-stage DC/AC scheme, that is the 3-phase inverter with the AC motor and one equivalent battery with no DC/DC stage. In recharge, the equivalent battery voltage is 330V, that is the dc-link level controlled by the DC/DC stages for this operation. The integral battery charger concept is proposed here independently of the topology complications of the particular scooter prototype. The performance and the implementation issues of the battery charger are the same with the actual DC/DC/AC scheme as well as with the simplified DC/AC one. The only condition to be respected for permitting the boost rectifier operation is that the voltage of the inverter dc-link (v_{batt} in Fig. 1) must be higher than the AC mains peak voltage: this means having a very high voltage battery ($\geq 330V$ with 220V, 50Hz) or a DC/DC stage between the battery and the inverter.

The additional hardware necessary for charger operation is evidenced as *extra hardware components* in Fig. 1 and consists of a single-phase passive rectifier, a light EMI filter (not represented in the figure) and a mechanical switch to access the center tap of the motor. Moreover, the measure of the AC mains voltage is needed. All the other measures are already available for the AC motor control. The overall weight of the extra-hardware is less than 0.5kg.

Due to the single-phase AC supply, the battery current has a significant 100Hz component, that could only be avoided by the adoption of bulky filter capacitors, that do not fit the volume and weight requirements of the integrated charger. The consequences of such a current on the battery lifetime depend on the battery technology but no negative effects have been outlined so far [8, 9].

Current control.

The input current i_0 of the PFC battery charger, defined in (1), is controlled for having unitary power factor: the i_0^* reference is synchronized to the AC voltage as described in Fig. 2. Also the current harmonics injected into the AC mains are nearly zero. The PWM harmonics are minimized by interleaving the three phases, as explained in the following.

$$\begin{bmatrix} i_a \\ i_b \\ i_c \end{bmatrix} = \begin{bmatrix} 1 & 0 & 1/3 \\ \sqrt{3}/2 & -1/2 & 1/3 \\ -\sqrt{3}/2 & -1/2 & 1/3 \end{bmatrix} \cdot \begin{bmatrix} i_\alpha \\ i_\beta \\ -i_0 \end{bmatrix} \quad (1)$$

The reference input current I_0^* is set by the BMS (Fig. 2). The BMS is on-board of the battery pack, and has been described in detail in [10]. In a few words, the BMS measures the voltage of the 70 series elements of the battery and sets the I_0^* reference in order to regulate the battery current or voltage accordingly.

The phase currents are balanced by the control of the differential mode currents [11]. In this particular case, it means to set to zero the bi-phase currents of the AC motor, in any reference frame, either the α, β frame used in (1), or the d, q rotating frame defined in Fig. 3-b that is the one used by the AC vector control. If $i_d = i_q = 0$ then the three phase currents are equal (2).

$$i_d = i_q = 0 \Rightarrow i_\alpha = i_\beta = 0 \Rightarrow i_a = i_b = i_c \quad (2)$$

The input current control is integrated in the AC motor control firmware: the duty-cycle D_0 that controls the rectified current (Fig. 2) is the common mode of the phase duty-cycles of the inverter and is added to the dq regulators output as evidenced in Fig. 3.

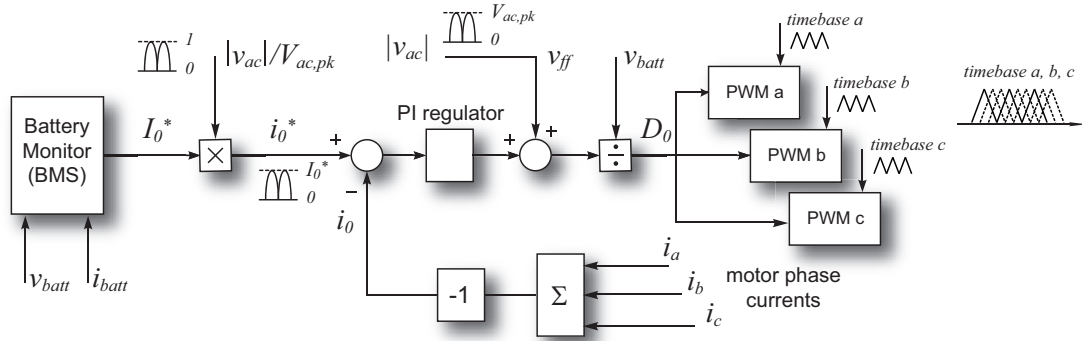

Figure 2: Current control of the PFC boost battery charger with interleaved phases.

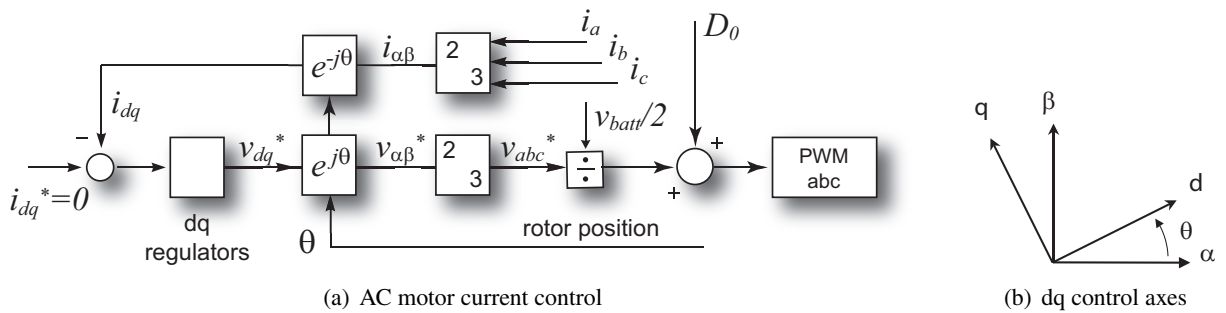

Figure 3: The vector control of the AC motor controls zero dq currents to keep the phase currents balanced.

Dealing with the performance of the PFC current controller, the feed-forward term v_{ff} in Fig. 2 is important to obtain a good tracking of the reference current, in particular around the zero crossing of the AC voltage where the i_0^* reference has a sudden change. The main component of the v_{ff} term is the rectified AC voltage $|v_{ac}|$. Other two feed-forward components should account for the inductive series drops (the series inductance of the PFC converter), that requires a negative phase shift (delay) of the controlled voltage [12] while the PWM time discretization would require a positive phase-shift (advance) of the controlled voltage in order to be compensated [13]. Practically speaking, the two phenomena compensate each other in the proposed prototype, and the v_{ff} term coincides with the rectified voltage as reported in Fig. 2.

Phase interleaving.

The three phases of the inverter are interleaved by setting three equally spaced PWM carriers, as evidenced in Fig. 2. In the prototype, the three independent synchronous timebases are generated by a FPGA, but many DSP controllers for standard motion control are able to implement separate synchronous timers.

Phase interleaving drastically reduces the ripple of the input and the output current, avoiding the need for additional filters toward the battery and the AC mains [14]. Due to the magnetic coupling of the three motor phases, the result of interleaving is a multilevel boost [6] that is one of the more suitable conversion structures proposed in the literature for single phase PFC rectifiers [15]. As said, input and output current ripples are very small [16], while the efficiency and the current dynamics are better than in non-coupled structures [17, 18]. In particular, there is no big issue with discontinuous current operation as in non-coupled interleaved structures.

The performance of the proposed battery charger depends on the inductances of the traction motor. An Interior-Permanent-Magnet (IPM) motor with anisotropic rotor is adopted by the scooter prototype. The magnetic model of the motor must include the zero-sequence inductance [19] that is usually not considered for AC drives control purposes. The 4-wire AC motor model as well as the experimental identification of the motor inductances at PWM frequency useful for forecasting the current ripple of the PFC rectifier are reported in [20].

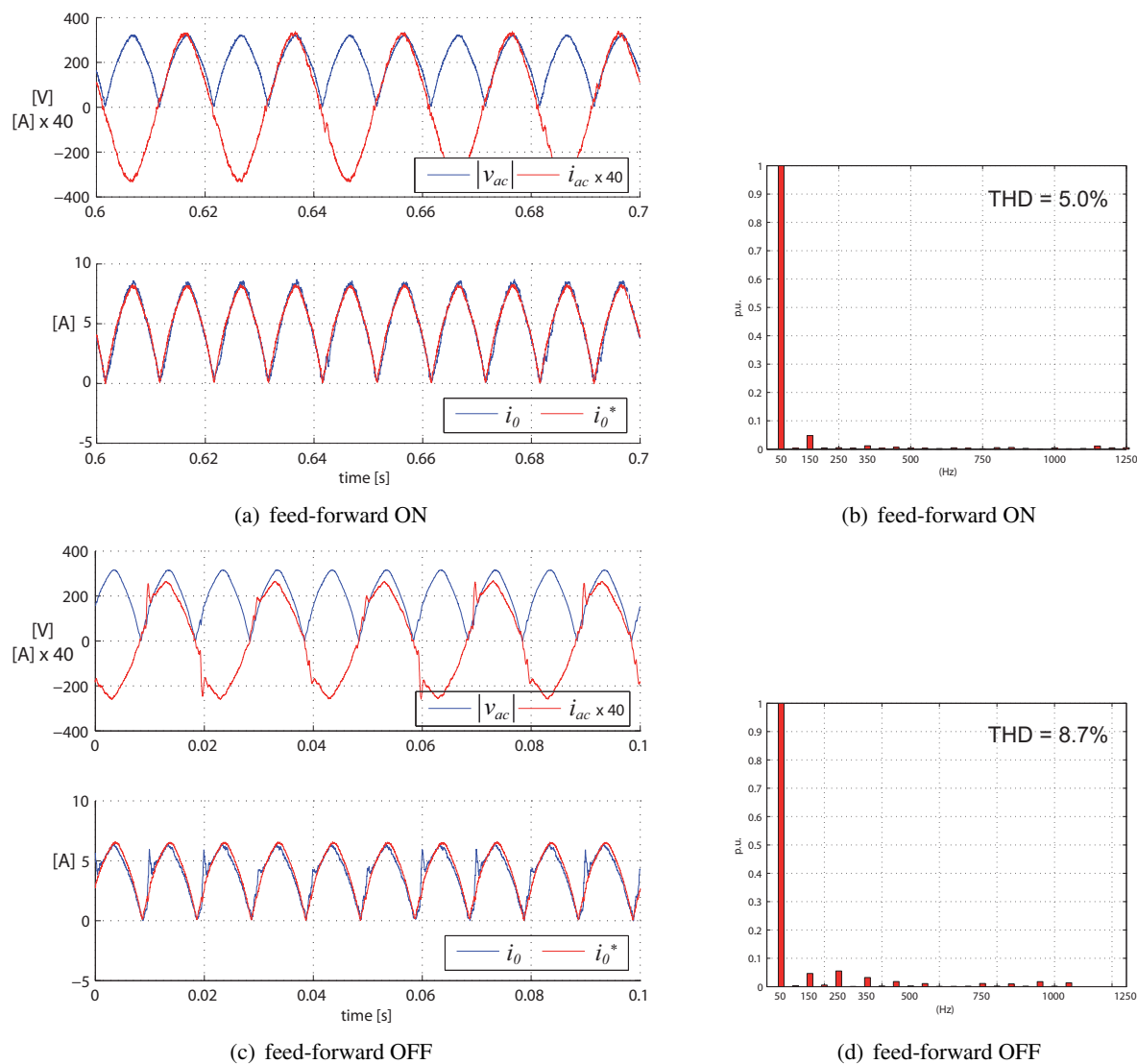

Figure 4: Effect of voltage feed-forward on the PFC control performance. a) and c) AC current, rectified voltage and controlled current waveforms with and without the v_{ff} injection; b) and d) Spectrum of the AC mains current in the two cases.

Experimental results.

The experimental setup is the scooter itself. The control board is capable of logging the DSP data in real-time during operation, thus the variables used by the scooter control are the ones actually reported in the following. The details of the power and control hardware can be found in [7]. The input power is limited to $1.5kW$, that is compatible with a standard household outlet. This corresponds to 3 hours and 30 minutes for completely recharge the $5kWh$ batter packs. Apart for the limitation imposed by the AC source, a faster recharge would be possible, according to the inverter and motor size: the maximum traction power is $10kW$ and corresponds to the battery overload capability in discharge that is larger than the one recommended by the manufacturer in charging conditions. The practical limitation to recharge speed are then imposed by the AC mains limited power and by the battery specifications and not by the hardware.

The performance of the PFC control on the AC side is summarized in Fig. 4, where the AC current and the rectified AC voltage in the same plot stand for the correct control tracking. The unity power factor and the negligible harmonic distortion are evidenced in subfigure . In the right plot of Fig. 4 the i_0 actual and reference current traces demonstrate the effectiveness of the current control.

In Fig. 5 the two battery currents (the scooter has two battery packs) are reported at different stages of the charge process. In the early stage (left), that corresponds to current-controlled charge mode, the full power is absorbed by the AC mains and an average current of $2.5A$ for each battery results. In the late stage (right), or the voltage-controlled mode, the current is limited by the BMS according to the battery requirements. The $100Hz$ component of the battery currents is evident in the figure.

In Fig. 6 the final stage of the charge is reported. The two batteries have slightly different current requests and the voltage is constant, apart for the $100Hz$ voltage drop.

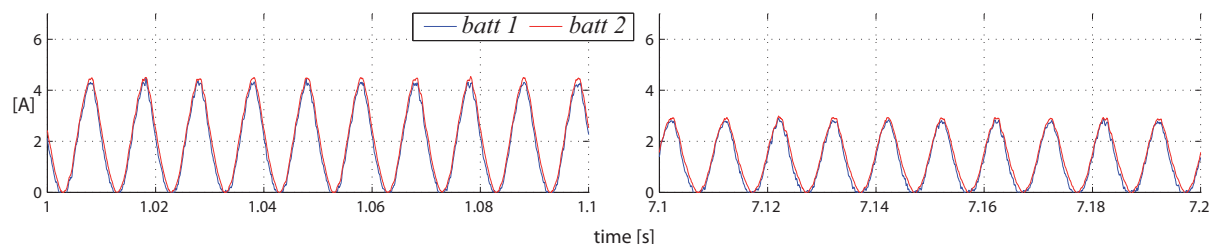

Figure 5: Current of the two battery packs at early and late stages of re-charge. Left: recharge at full current (current-controlled charge). Right: current limitation by the BMS (voltage-controlled charge).

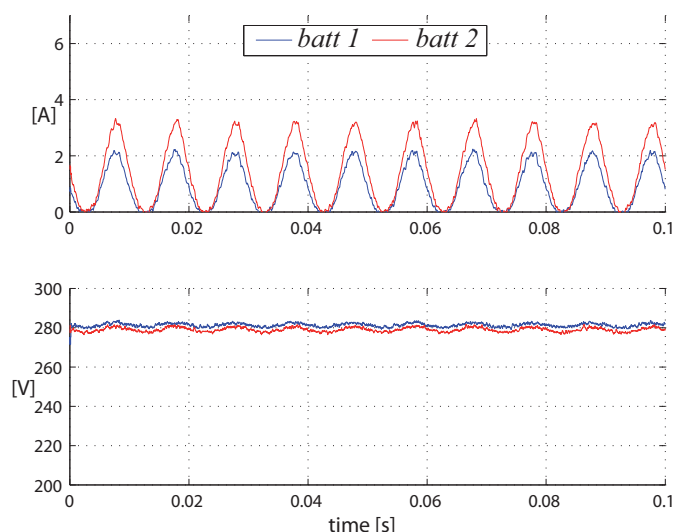

Figure 6: Current and voltage of the two battery packs at very late stage of re-charge. Top: the BMS requires different charge currents for the two batteries. Bottom: the battery voltages are the same (voltage-controlled charge).

Conclusions

A PFC battery charger integrated in the traction hardware of an electric scooter has been shown and tested. The scooter battery is recharged by a single phase household outlet, that is 220V, 50Hz in this case. The overall weight of the additional components is well above 0.5kg and there is no extra-cost in terms of control hardware. The AC motor is used as the coupling inductor of the obtained 3-phase boost converter with interleaved phases. The AC mains current is controlled at unitary power factor and with minimal harmonic distortion. This is made possible by the high voltage dc-link of the traction drive, that has to be higher than the AC mains peak value. For this reason, the proposed concept PFC charger concept applies either to very high voltage batteries (e.g. > 320V with 220V mains) or to lower voltage batteries with additional DC/DC step-up stage. In any case, with single phase AC supply, the battery is affected by 100Hz current ripple that did not show any particular disadvantage in terms of battery exploitation and lifetime.

APPENDIX: Scooter Prototype Ratings

Table I: Scooter prototype ratings.

SCOOTER DATA			BATTERY DATA		
Total weight	2 passengers	320 kg	Voltage range	V_{batt}	200 ÷ 300V
Max Speed		90 ÷ 100km/h	Voltage (typ)	V_{batt}	260 V
Driving range	@ 50km/h	130km	Max Current	I_{batt}	2 x 30 A
Driving range	@ 90km/h	60 km	Weight		2 x 24 kg
Traction Power (cont)	P_{nom}	7 kW	Capacity		2 x 10 Ah
Traction Power (peak)	P_{max}	10 kW			

References

- [1] J. Carlos Gomez and Medhat M. Morcos. Impact of ev battery chargers on the power quality of distribution systems. *IEEE TRANSACTIONS ON POWER DELIVERY*, 18(3):975 – 981, 2003.
- [2] David Thimmesch. An scr inverter with an integral battery charger for electric vehicles. *Industry Applications, IEEE Transactions on*, IA-21(4):1023–1029, July 1985.
- [3] Seung-Ki Sul and Sang-Joon Lee. An integral battery charger for four-wheel drive electric vehicle. *Industry Applications, IEEE Transactions on*, 31(5):1096–1099, Sep/Oct 1995.
- [4] L. Solero. Nonconventional on-board charger for electric vehicle propulsion batteries. *IEEE TRANSACTIONS ON VEHICULAR TECHNOLOGY*, 50(1):144 – 149, 2001.
- [5] P. Guglielmi, G. Pellegrino, G. Griffero, S. Nieddu, G. Giraudo, and A. Vagati. Power conversion concepts for advanced autonomy and reliability electric scooter. In *Proc. of IEEE IECON '03*, volume 3, 2003.
- [6] Po-Wa Lee, Yim-Shu Lee, Cheng D.K.W., and Xiu-Cheng Liu. Steady-state analysis of an interleaved boost converter with coupled inductors. *IEEE Transactions on Industrial Electronics*, 47(4):787 – 795, 2000.
- [7] E. Armando, P. Guglielmi, M. Martino, and M. Pastorelli. Big electric scooter: an experience from lab to the road. *Industrial Electronics and Applications, 2008. ICIEA 2008. 3rd IEEE Conference on*, pages 1680–1684, June 2008.
- [8] F. Lacressonniere, B. Cassoret, and J.-F. Brudny. Influence of a charging current with a sinusoidal perturbation on the performance of a lead-acid battery. *Electric Power Applications, IEE Proceedings -*, 152(5):1365–1370, Sept. 2005.
- [9] Jack Winnick Paul A. Kohl Jun Li, Edward Murphy. The effects of pulse charging on cycling characteristics of commercial lithium-ion batteries. *Journal of Power Sources*, 102:302–309, 2001.
- [10] A. Affanni, A. Bellini, G. Franceschini, P. Guglielmi, and C. Tassoni. Battery choice and management for new-generation electric vehicles. *Industrial Electronics, IEEE Transactions on*, 52(5):1343–1349, Oct. 2005.

- [11] A. Garg, D.J. Perreault, and G.C. Verghese. Feedback control of paralleled symmetric systems, with applications to nonlinear dynamics of paralleled power converters. *Circuits and Systems, 1999. ISCAS '99. Proceedings of the 1999 IEEE International Symposium on*, 5:192–197 vol.5, 1999.
- [12] D.M. Van de Sype, Koen De Gussemé, A.P.M. Van den Bossche, and J.A. Melkebeek. Duty-ratio feedforward for digitally controlled boost pfc converters. *Industrial Electronics, IEEE Transactions on*, 52(1):108–115, Feb. 2005.
- [13] Hung-Chi Chen and Chih-Kai Huang. Phase feedforward control for single-phase boost-type smr. *Applied Power Electronics Conference and Exposition, 2008. APEC 2008. Twenty-Third Annual IEEE*, pages 1313–1318, Feb. 2008.
- [14] R. Redl and L. Balogh. Power-factor correction in bridge and voltage-doubler rectifier circuits with inductors and capacitors. *Applied Power Electronics Conference and Exposition, 1995. APEC '95. Conference Proceedings 1995., Tenth Annual*, (0):466–472 vol.1, Mar 1995.
- [15] J. Salmon, A. Knight, J. Ewanchuk, and N. Noor. Multi-level single phase boost rectifiers using coupled inductors. *Power Electronics Specialists Conference, 2008. PESC 2008. IEEE*, pages 3156–3163, June 2008.
- [16] H.-B. Shin, J.-G. Park, S.-K. Chung, H.-W. Lee, and T.A. Lipo. Generalised steady-state analysis of multi-phase interleaved boost converter with coupled inductors. *Electric Power Applications, IEE Proceedings -*, 152(3):584–594, May 2005.
- [17] Pit-Leong Wong, Peng Xu, P. Yang, and F.C. Lee. Performance improvements of interleaving vrms with coupling inductors. *Power Electronics, IEEE Transactions on*, 16(4):499–507, Jul 2001.
- [18] Wei Wen and Yim-Shu Lee. A two-channel interleaved boost converter with reduced core loss and copper loss. *Power Electronics Specialists Conference, 2004. PESC 04. 2004 IEEE 35th Annual*, 2:1003–1009 Vol.2, June 2004.
- [19] T. Matsuo and T.A. Lipo. Rotor position detection scheme for synchronous reluctance motor based on current measurements. *Industry Applications, IEEE Transactions on*, 31(4):860–868, Jul/Aug 1995.
- [20] G. Pellegrino, E. Armando, and P. Guglielmi. An integral battery charger with power factor correction for electric scooter. *Proc of IEEE International Electric Machines and Drives Conference, IEMDC 2009*, May 2009.