

Bowling Green State University
ScholarWorks@BGSU

Master of Technology Management Plan II
Graduate Projects

College of Technology, Architecture and Applied
Engineering

Summer 7-30-2015

Developed Pipe Bursting Specifications Using High Density Poly Ethylene (HDPE)

Manoj Mohanraj
Bowling Green State University

Follow this and additional works at: https://scholarworks.bgsu.edu/ms_tech_mngmt



Part of the [Construction Engineering and Management Commons](#), and the [Transportation Engineering Commons](#)

Recommended Citation

Mohanraj, Manoj, "Developed Pipe Bursting Specifications Using High Density Poly Ethylene (HDPE)" (2015). *Master of Technology Management Plan II Graduate Projects*. 15.
https://scholarworks.bgsu.edu/ms_tech_mngmt/15

This Thesis is brought to you for free and open access by the College of Technology, Architecture and Applied Engineering at ScholarWorks@BGSU. It has been accepted for inclusion in Master of Technology Management Plan II Graduate Projects by an authorized administrator of ScholarWorks@BGSU.

**DEVELOPED PIPE BURSTING SPECIFICATIONS USING HIGH DENSITY
POLY ETHYLENE (HDPE)**

Manoj Mohanraj

A Major Project

Submitted to the Graduate College of Bowling Green

State University in partial fulfillment of

The requirements for the degree of

Masters in Technology Management

2015

Committee:

Dr. Alan Atalah

ABSTRACT

Pipe bursting is a trenchless method for replacing old deteriorated or under sized pipe by fracturing or splitting. Earlier published pipe bursting specifications do not completely cover the current state of the art and without proper allocation of risks. Specifications are set of written instructions given by the owner to the contractor. The developed Pipe Bursting specification with HDPE will help the owners, contractor, and engineers to carry out a successful burst timely and economically. In this research study, sixteen specifications from various sources were collected. Various agreements and disagreements among these specifications were identified, analyzed, and considered while developing the draft specification reflecting the current state of art. Based on these findings, the following topics are identified for the specification and instructions are given accordingly: General, Definitions, Reference Standards, Qualifications of the Contractor, Submittals, Pipe Fusion, Methods of Pipe Bursting, Testing and Inspection, Locating Utilities and Service Connections, Bypassing the flow, Traffic Control Plans, Service Reconnection, and Site Restoration. The proposed draft specification adopted the statements agreed upon by the majority of the specifications and conformity with the current state of the art. Peer reviewing by industry experts can further develop the draft specifications.

Table of Contents

CHAPTER 1 - INTRODUCTION.....	1
Context of the Problem	1
Statement of the Problem	4
Objectives of the Study	4
Significance of the Project	4
Definition of Terms.....	5
CHAPTER 2 – LITERATURE REVIEW	7
Introduction	7
History of Pipe Bursting.....	7
Pipe Bursting Systems.....	8
Pneumatic Pipe Bursting	8
Static Pipe Bursting	9
Insertion and Pulling Shafts	10
Construction Guidelines for Good Practice	11
Degree of Upsizing.....	11
Conditions that Limit the Favorability of Pipe Bursting.....	12
Comparison between Pipe Bursting and Traditional Open Cut	14
Effects of Pipe Bursting	14
Condition Assessment of the Pipe Systems	15

High Density Poly Ethylene (HDPE).....	16
Submittals.....	16
Summary	17
CHAPTER 3 - METHODOLOGY.....	18
Restatement of the Problem	18
Objectives of the Study	18
Collected Specifications.....	18
Washington Suburban Sanitary Commission - Pipe Bursting System	18
SKE Construction - Pipe Bursting Bid Specs.....	19
San Antonio Water System - Pipe Bursting/Crushing Replacement Process	19
Orange County Utilities - Pipe Bursting of Gravity Sewers	19
Baton Rouge Projects - Section 811 Pipe Bursting	20
B/CS Unified - Sanitary Sewer Pipe Bursting.....	20
Denver Engineering Division - Construction Specifications	20
Ontario Provincial and Standard Specification - Pipe Bursting	20
Metropolitan Sewerage District of Buncombe County – Pipe Bursting	21
Australasian Society of Trenchless Technology - Specifications for Pipe Bursting.	21
Greater Peoria Sanitary District – Specifications - Pipe Bursting.....	22
Knoxville Utilities Board - Sanitary Sewer Pipe Bursting with HDPE	22
Oregon Department of Transportation – Pipe Bursting and Lining for Gravity Pipe	22

Commonwealth of Massachusetts– Guidelines for Pipe Bursting	22
IPBA - Suggested Standard Specification for Pipe Bursting	23
Louisiana Department of Transportation – Pipe Bursting/Crushing	23
Evaluation and Comparison of the Collected Specifications	23
CHAPTER 4 - FINDINGS	25
General	25
Definitions	25
Reference Standards	26
Qualifications of the Contractor	27
Submittals	32
Pipe Fusion	33
Methods of Pipe Bursting	33
Testing and Inspection	34
Locating Utilities and Service Connections	35
Bypassing the Flow	35
Traffic Control Plans	36
Site Restoration	37
CHAPTER 5 - SUMMARY AND DISCUSSIONS	38
Summary	38
Discussions	38

Reference Standards	38
Qualifications of the Contractor	38
Submittals	39
Pipe Fusion	40
Methods of Pipe Bursting	40
Testing and Inspection.....	40
Locating the Utilities and Service Connections	41
Bypassing the Flow	41
Traffic Control Plan.....	42
Service Reconnection	42
Conclusions	42
Further Research	42
References.....	44
APPENDIX A.....	48

List of Tables

Table 1: Project Design Considerations (IPBA, 2012)..... 12

Table 2 : Summary comparison of the first eight collected Specs..... 28

Table 3 : Summary comparison of the second eight collected specs..... 30

List of Figures

Figure 1 : The pipe bursting operation layout..... 2

Figure 2: Bursting head of the Pneumatic System (Atalah, 2008) 8

Figure 3: Bursting head of a Static Pull System (Simicevic & Sterling, 2001)..... 10

CHAPTER 1 - INTRODUCTION

Context of the Problem

In the construction industry, specifications are very important for carrying out a project successfully. Specification is one of the contract documents, along with the drawings, the agreement, and many other documents. Since the specifications are written instructions, they are frequently adjudged by the courts as having greater importance than drawings when these documents are in conflict, and judgments are frequently resolved based on the specifications (Rosen, 1999). The main function of any specification is to provide detailed description about the quality of the materials and products, and provide the dimensions and other information that are not shown in the drawings. Several specifications have been developed for pipe bursting over the years that helped the industry by providing the best and latest practices in the pipe bursting industry at that time.

Pipe bursting is a well-established trenchless method for replacement of deteriorated or undersized gas, sewer, or water pipes. It is one of the widely accepted pipe replacement methods for the past 35 years in the Europe and the United States. Pipe bursting replaces an existing pipe with a new pipe of the same or larger diameter in the same location. This technology is cost effective if the existing pipe has fewer lateral connections, when additional capacity is needed and/or the old the pipe is structurally deteriorated.

In the process of pipe bursting, a cone shaped tool (bursting head) is inserted into the old pipe as shown in Figure 1. The bursting head fractures the old pipe and simultaneously, a new pipe attached behind the bursting head is installed by pushing or pulling. The base of the bursting head is larger than the inside diameter of the old pipe to cause the pipe fracture, pipe debris displacement, hole enlargement to accommodate the new pipe and to reduce friction between

the outside surface of the new pipe and the surrounding soils (Simicevic & Sterling, 2001). The new pipe is connected to the rear end of the bursting head whereas the front end is connected to a pulling rod or cable. The bursting head and the new pipe are launched from the insertion pit, and the cable or pulling rod is pulled from the reception pit. Once the bursting head is pulled into the reception pit, it is separated from the pipe. The cable/rod pull together with the shape of the bursting head keeps the head following the existing pipe, and specially designed heads can help to reduce the effects of existing sags or misalignment on the new pipeline (Simicevic & Sterling, 2001).

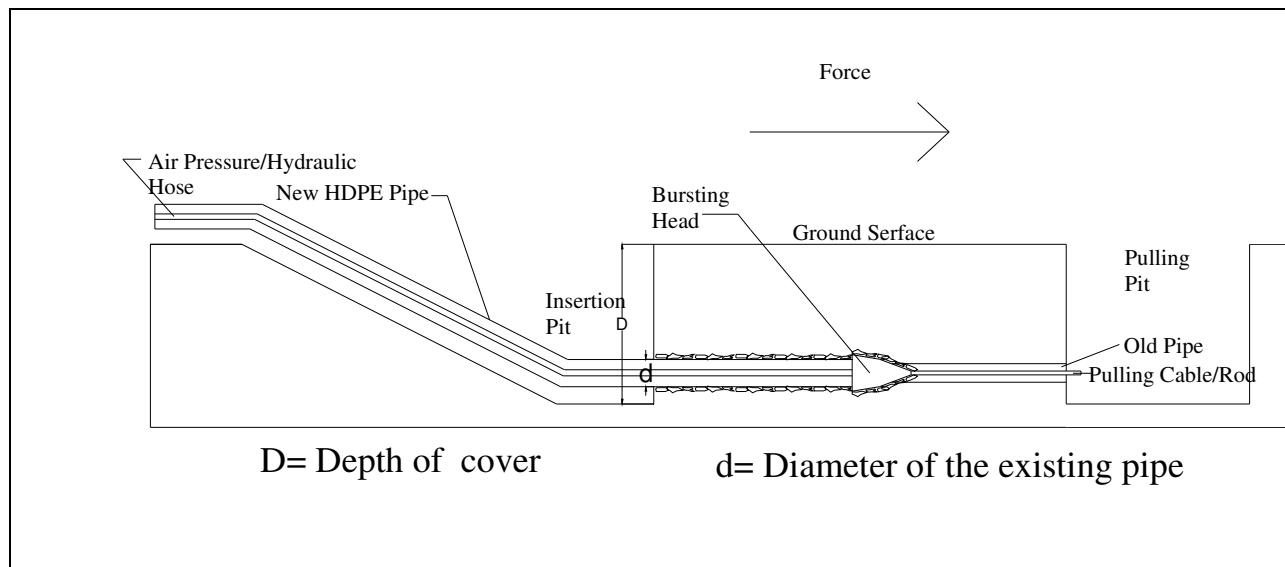

Figure 1 : The pipe bursting operation layout

There are three main types of pipe bursting systems: Pneumatic, Hydraulic, and Static pull. The selection of a specific replacement method depends on soil conditions, groundwater conditions, required degree of upsizing, type of new pipe, construction of the existing pipeline, depth of the pipeline, availability of experienced contractors, and so on (Atalah, 2008). Pipe bursting can be used to replace almost all types of pipes including clay pipes, cast iron, asbestos cement, plain concrete pipes, steel, ductile iron, galvanized iron, HDPE, and PVC. The replacement pipes that can be used include HDPE, PVC, ductile iron, and clay pipes, however,

High-and medium-density polyethylene (HDPE and MDPE) is most used pipe material in pipe bursting applications.

According to Plastic Pipe Institute (2008), the advantages of the polyethylene pipes are long-term durability against environmental degradation, trouble – free installation, flexibility and resistance to chemicals. HDPE has excellent flow characteristics, as polyethylene is smoother compared to steel, ductile iron or concrete pipes. The process of butt fusing the pipe segments together in the field produce a continuous jointless pipe. This unique fusing method add significant advantage to HDPE in cost reductions when compared to other pipe material (Plastic Pipe Institute, 2008). The flexibility allows bending the pipe for angled insertion in the field. In addition, HDPE is a versatile material that meets all the other requirements for gas, water, and wastewater lines (Atalah, 2008).

Different pipe bursting manufacturers have developed specifications for their systems. Some owners and engineers developed specification for specific projects. Some of these specifications were developed many years ago and therefore do not cover the current practices and developments. The need for updating the specifications rose as the existing specifications are not complete and are not up to date. For example, according to National Association of Sewer Service Company (NASSCO) (2003), the contractor carrying out the pipe bursting process should be licensed by the bursting system manufacturer and pay the royalty to the British Gas company. However, the bursting system manufacturer does not need to certify experienced bursting contractors and British Gas's patent has expired in 2005. According to Najafi (2006), the selection of construction method should not be left to the contractors. The author feels that the contractors are best positioned to perform their work depending upon their available crew and equipment and the method selection process is the domain of the contractor. According to

International Pipe Bursting Association (2012), the experience of the contractor should be at least three years and the contractor must have installed 50,000 ft. under similar conditions. This requirement is not suitable for all projects (specially small ones) as the higher threshold of experience eliminate some suitable contractors reducing competition and aiding in increasing the bid price. According to NASSCO (2003), contractor shall hold the Contracting Authority and Engineering Firm completely harmless in any legal action resulting from patent infringements. However, the patent expired and this request becomes irrelevant. Evidently, these specifications need to be updated to reflect the current state of the art (Pipe bursting).

Statement of the Problem

Pipe bursting has been significantly developed since its inception in the 1970s. With the continuous development of this technique, earlier published specifications are incomplete and lacking proper allocation of risk and do not reflect the current state of the art. The problem of this study, therefore, is to develop a potential comprehensive specification that reflect the current state of pipe bursting.

Objectives of the Study

- To collect and extensively review the specifications, guidelines and other informations related to pipe bursting, which are available in the market place.
- To evaluate and compare the existing specifications with each other to identify the issues of agreement and disagreements among these specifications
- Develop a first draft specifications for pipe bursting using the good practice guidelines.

Significance of the Project

The developed pipe bursting specification using HDPE will help engineers and contractors to carry out successful bursts economically and timely. Good specification properly

allocate risks to the entity that is best positioned to manage these risks. Consequently, the contractor will reduce the risk mark up and through competition among bidding contractors, the bid prices will go down. Good specification also reduce disputes saving valuable time and money for all the project parties. Many factors are reviewed by engineers before embarking on a pipe bursting process to find the most cost-effective and environmentally friendly method. The specifications generally segregate the information depicted on the drawings into the various specification sections so that a contractor can generally select subcontractors on the basis of the specifications breakdown of sections (Rosen, 1999).

The necessity for this specification of pipe bursting arose due to the continuous improvement in the field and lack of adequate upto date engineering specifications. This specification is an advancement towards promoting best practices techniques and developing a knowledge-base for pipe bursting projects. This specification will help the owners, contractors and engineers plan and execute the projects efficiently and safely with respect to the project requirements and site condition. Additionally, this specification identifies the potential risks associated with the process and the preventive steps to be taken are addressed which in turn improves the confidence in appropriate use of the process.

Definition of Terms

Trenchless technology – Trenchless Technology is defined as “a family of methods, materials, and equipment capable of being used for the installation of new, replacement, or rehabilitation of existing underground infrastructure with minimal disruption to surface traffic, business, and other activities" (IPBA, 2012).

Pipe Bursting - Pipe bursting is defined as a trenchless replacement method in which an existing pipe is broken either by brittle fracture or by splitting using an internal mechanically

applied force applied by a bursting tool. At the same time, a new pipe of the same or larger diameter is pulled in replacing the existing pipe (IPBA, 2012).

HDPE - High-density polyethylene (HDPE) or polyethylene high-density (PEHD) is a polyethylene thermoplastic made from petroleum. HDPE pipes are known for its large strength to density ratio. HDPE pipes are commonly used in the production of plastic bottles, corrosion-resistant piping, geo membranes, and plastic lumber (Ceresana, 2014).

Specifications - Specifications define the qualitative requirements of materials and products to ensure that everyone understands the product requirements (Betts, 2000)

CHAPTER 2 – LITERATURE REVIEW

Introduction

This chapter includes presentation of the history of pipe bursting, methods of pipe bursting, effects of pipe bursting, construction guidelines for good practice, construction problems, and solutions to avoid them. Several project related documents are also reviewed below.

History of Pipe Bursting

Pipe bursting has a long history, which would have never been successful without the piercing tool and horizontal pipe ramming techniques. Initially, the idea of replacing the pipes through bursting was proposed by British Gas and the UK based DJ Ryan engineering company in the late early 1970s for replacement of small diameter, 3- and 4-inch cast iron gas mains (Howell, 1995). In 1981, British Gas and DJ Ryan applied for the first basic methods and equipment patents in the UK. More patents followed in Europe, Japan, USA and South America (Rameil, 2007). In 1975, some contractors used the process with help of some self-made equipment, but then it was not termed as pipe bursting. The contractors were performing this process in many locations, including the United States and Germany (TT-Group, 2009). At that time, pipe-bursting system was pneumatically driven cone shaped head operated by reciprocating impact process. British Gas patented this method in 1981 in the U.K and 1986 in the US, and it expired in April 2005 (Hashemi, 2008). Initially, pipe bursting was used only in the replacement of cast iron gas distribution lines and later it was used for replacing sewer and water lines. By 1985, the process was further developed to install up to 16-inch outer diameter (OD) medium-density polyethylene (MDPE) sewer pipe. Currently, pipe bursting is used to replace water lines, gas lines, and sewer lines throughout the world (Atalah, 2008).

Pipe Bursting Systems

One of the several trenchless techniques developed up to date, can be used to replace the existing old pipes. There are two commonly used pipe bursting methods such as, pneumatic and static pipe bursting. The basic differences among these systems is in the source of energy and the method of breaking the old pipe and some consequent differences in operation (Atalah, 2008). The following paragraphs describes briefly about the types of pipe bursting system.

Pneumatic Pipe Bursting

Pneumatic pipe bursting is the most commonly used pipe bursting system. In the pneumatic pipe bursting, the bursting head is a cone-shaped soil displacement hammer (Figure 2). Compressed air drives the process that is operated at a rate of 180 to 580 blows/minute. The action of the bursting head is similar to the hammering of a nail into the wall; with each blow the nail moves more inside the wall. Likewise, with each impact, the bursting head fractures the pipe and thus end up breaking the pipe completely.

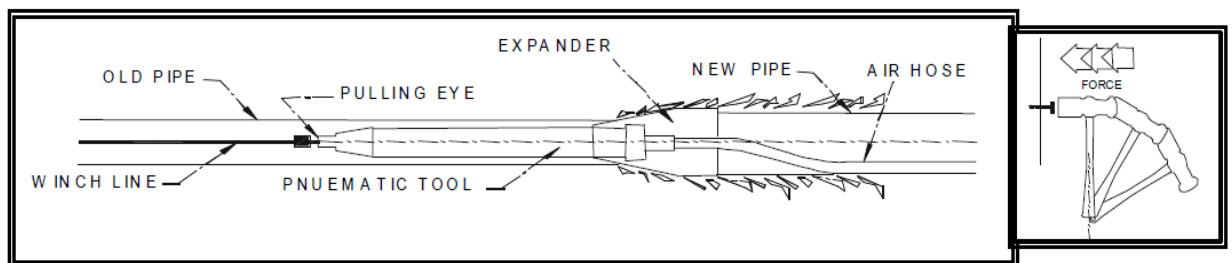

Figure 2: Bursting head of the Pneumatic System (Atalah, 2008)

With the help of a winch, a constant tension is applied to the bursting head through a cable which is inserted through the old pipe and connected to the bursting head. This in turn aligns the head with the old pipe and pushes it against the existing pipe wall and inserts the new pipe. The expander can be front-end (attached to the frontend of the hammer) for pipes

smaller than 12” or back-end (attached to the backend of the hammer) for pipes larger than 12” (Atalah, 2008). An air pressure hose is inserted through the new pipe and connected to the rear of the bursting tool. The bursting process starts as soon as the bursting head is connected to the new pipe, the winch cable through which constant tension is applied, is connected to the bursting head through the old pipe and the air pressure and the winch are set up at a constant pressure and tension values.

Static Pipe Bursting

The Static Pull method is the second most common pipe bursting method used. In this method, force is applied to the bursting head with the help of the rod assembly or winch cable, which is inserted through the existing pipe (Figure 3). The head transfers the horizontal pulling force into radial force, which fractures the old pipe and enlarging the cavity, which makes way for the new pipe. From the pulling shaft, the steel rods, which is about four feet long each, are inserted through the existing pipe. The rods are connected together using different types of connections. When the rods reach the insertion shaft, the bursting head is connected to the rods and the PE pipe is connected to the rear of the head (Atalah, 2008). During the bursting process, the hydraulic unit pulls the rods towards them until the length of the individual rods and then the rod sections are removed. The process will continue until the bursting head reaches the pulling shaft where the head will be separated from the new pipe. While using a winch cable instead of the rod assembly, the process can be continuous. However, the tensile force in the cable system is much less compared to that of the rod system. Proper shoring of the insertion and pulling shafts is essential for the safety of the workers and the safety of the surrounding environment (Atalah, 2008). In pulling shafts, one side of the pulling shaft or the wall will experience thrust from the winch. This side of the pulling shaft should be able to withstand the pressure

approaching from the winch. Hence, there is a need for a thrust block or structure in order to distribute the force over a larger area. In static pipe bursting, a thrust block should be constructed against which pulling system thrusts during the pulling and bursting process. The thrust block, shoring, and soil behind the shoring must be able to withstand the stresses from the pulling system (Atalah, 2008).

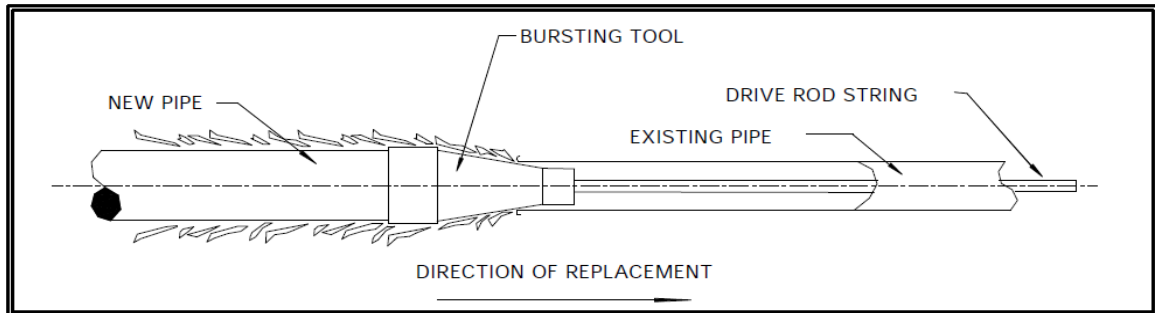

Figure 3: Bursting head of a Static Pull System (Simicevic & Sterling, 2001)

Insertion and Pulling Shafts

An insertion shaft is an excavation or an existing layout condition that allows new pipe accompanied with appropriate pipe bursting tooling to be inserted into the existing pipe. A pulling shaft is an excavation or an existing layout condition that allows the new pipe and the appropriate associated tooling to be received and also allows the pipe burst tooling to be removed (IPBA, 2012). The optimization of the location of insertion and pulling shafts is the first step in planning the pipe bursting operation. These shafts can be planned in manholes or lateral connections in case of sewer lines and fire hydrants in case of water lines. The insertion shaft has a flat section and sloped section; the flat portion has to be long enough to allow aligning the centerlines of the bursting head with that of the old pipe. The sloped section has to be long enough to allow the PE pipe to bend without any negative impact on the pipe (i.e.) to accommodate the bending radius requirements of the pipe (Atalah, 2008). The diameter of the pipe and the required space around the pipe determines the width of the pit. The pulling pit

should have sufficient space to operate the winch or pull back device and the removal of the bursting head.

Construction Guidelines for Good Practice

Similar to any underground utility construction, various factors limit the potential use of a technology. Some factors might affect the potential use of pipe bursting from a technical aspect whereas some factors might affect its potentiality financially. The success of the pipe bursting project is dependent on the qualifications of the project team, geotechnical conditions, existing pipe material and condition, burst length, depth of pipe, and degree by which the pipe diameter will be increased. The following gives some construction guidance about the size of the replacement pipe.

Degree of Upsizing

Since the pipe bursting has the capability of replacing an existing pipe with a new pipe, which is of same or larger diameter, the terminologies stated below are used to compare the size of the new pipe with the existing pipe. The "degree of upsize" is the difference between the existing pipe inside diameter (ID) and the newly installed pipe outside diameter (OD) (IPBA, 2012). The size of pipes replaced by pipe bursting ranges from 2" Internal Diameter (ID) to 36" ID; however, technical advancements are being made for both smaller and larger pipes. The IPBA classifies pipe-bursting work into four classifications (Table 1). They are, A) Size on Size - refers to replacing an existing pipe with new pipe of similar internal diameter. B) Single Upsize - refers to replacing an existing pipe with new pipe that has internal diameter larger approximately by one nominal size. C) Double Upsize - refers to replacing an existing pipe with new pipe that has internal diameter larger approximately by two nominal sizes, Triple Upsize - refers to replacing an existing pipe with new pipe that has internal diameter larger approximately

by three nominal sizes. D) Developmental or Class D Upsize - refers to replacing an existing pipe with new pipe that has internal diameter larger than Triple Upsizing. Developmental upsize is attainable in certain cases, but it should be planned properly as greater force is required to expand the soil and install the new pipe. The risk of surface heave is increased tremendously based on the depth and the geotechnical conditions.

Table 1: Project Design Considerations (IPBA, 2012)

Classification	Depth of the Pipe (ft.)	Existing Pipe Diameter (in.)	New Pipe Diameter Options	Burst Length (ft.)
A – Minimal	<12	2–12	Size to Size	0 – 350
B – Moderate	<12 to <18	12 – 18	Single Upsize	350 – 500
C- Comprehensive	>18 +	20 – 36	Double / Triple Upsize	500 - 1000
D – Developmental				

Conditions that Limit the Favorability of Pipe Bursting

The potential ground condition problems for pipe bursting involve densely compacted soils and backfills, rock trenches, soils below the water table and soils that expand in volume as they are sheared, e.g. angular sands (IPBA, 2012). Because of these soil conditions, there is a need to increase the force necessary for the pipe bursting operation. For most soil conditions, it is sufficient to discharge required power for effective pipe bursting. When the soil provides a high friction drag on the pipe and the replacement length is long enough to generate high tensile forces on the replacement pipe, bentonite or polymer lubrication based mixes may be injected into the annular space behind the bursting head to help keep the hole open and to reduce the frictional drag on the replacement pipe.

During the bursting process, if excessive ground movement is expected near the existing structures, ground movements and vibrations plan should be developed. If dangerous movements are identified, it is mandatory to slow down the bursting rate. However, if the movement is still

high, the bursting process should be stopped until the cause is analyzed. If there is a gas line, water line, or sewer line that is too close to the bursting head and is at risk of damage, exposing the line reduces this risk significantly. The excavation to expose this utility should be done using means that do not damage the line such as vacuum or manual excavation (Atalah, 2008).

Similar to any underground construction project, the existence of ground water can potentially increase the level of difficulty in the pipe bursting operations in terms on both practical and technical perspectives. In certain soil conditions, groundwater can have a buoyant and effect of lubrication on the bursting operation, with groundwater flowing towards the open insertion pit and reception pit along the existing trench line. However, in certain soil conditions, groundwater will cause the annulus to close in quickly behind the expanding head, thus increasing pipe drag and theoretically reducing the practical burst lengths (IPBA, 2012). It is advisable to identify the presence of groundwater with the help of quality geotechnical reports.

Preferably, during bursting operation, the insertion and receiving pits are dry ensuring the operators to operate the equipment and connect the new pipe after installation. Dewatering plan should be a part of the construction plan that includes the proper disposal of the water removed from the trench. Even though the dewatering process increases the difficulty of bursting, but in comparison with open cut, which needs dewatering throughout the length of the trench, pipe-bursting dewatering is concentrated at the insertion, receiving and service points and hence reduces the complexity of the project.

Several engineers, manufactures and industry experts have developed specification for pipe bursting previously. Various-project-related information documents are reviewed below.

Comparison between Pipe Bursting and Traditional Open Cut

According to the “Guidelines for pipe bursting” (IPBA, 2012), when the pipeline is shallow, open cut may be a preferred option for pipe renewal. On the other hand, pipe bursting is considered to have tremendous advantages over open cut under many other conditions. Pipe-bursting advantages are more when compared to open cut because the cost of excavation, dewatering, and shoring increases as the depth of lines increases. While these factors have minimal effect on pipe bursting, indirect savings due to less traffic disturbance, shorter time for replacement, less business interruption, reduced environmental disturbance, reduced surface paving expenses and social benefits adds more advantages to pipe bursting over open cut method. Pipe bursting usually produces less ground disturbance than open cut replacement (Simicevic & Sterling, 2001). Even though the bursting costs the same or lesser than the open cut. The reduction in total effective costs compared to open cut makes the bursting attractive.

Effects of Pipe Bursting

According to “Guidelines for Pipe Bursting” (Simicevic & Sterling, 2001), every bursting process is associated with ground displacements. Even if the replacement is carried out size to size bursting, it affects the soil, as the bursting head is bigger than the existing pipe. Ground movements are not exclusive to pipe bursting, and they can be significant in open trench replacements of pipes as well (Rogers & Chapman, 1995). The ground displacements depend primarily on (1) degree of upsizing, (2) type and compaction level of the existing soil around the pipe, and (3) depth of bursting (Simicevic & Sterling, 2001). Before reaching the surface, if the ground movements are not attenuated, they result in either surface heave or settlement. Many factors determine whether the surface will heave or settle. If the existing soil is loose sand or relatively new trench backfill, which is yet to settle, the bursting process can result in more

settling of the soil. On the other hand, if the soil is well compacted and the pipe is not very deep, the bursting process is likely to create a surface heave, especially with significant upsizing of the existing pipe (Simicevic & Sterling, 2001). The authors discuss the ground vibrations and the study done by the Trenchless Technology Centre (TTC) for three different pipe replacement methods on ground vibrations. It states that soil particles in the ground experience some extent of vibration in all pipe-bursting operations. TTC did a study on the velocity of vibrational ground movement for the three pipe replacement methods: pneumatic, static and hydraulic system (Atalah, 1998). Several job sites with a variety of site conditions in various regions of the United States of America and TTC site in Ruston, Louisiana were taken into consideration for the study. The study showed that none of the pipe bursting techniques tested is likely to damage the nearby utilities if they are at a distance of more than a few feet from the bursting head (Simicevic & Sterling, 2001). During the bursting process, the impact of the bursting head, size and type of the existing pipe and the degree of upsizing determines the vibration levels. The Peak Particle Velocity (PPV) of the vibration caused by bursting is well below the threshold PPV of the buildings; therefore, pipe bursting is unlikely to cause cracks in the buildings. The study concluded that a person standing on the surface of the bursting process is more likely to experience ground vibrations. The levels of vibrations recorded in the pipe bursting operations on pipes 6” to 15” in the TTC tests are very unlikely to be damaging except at very close distances to the bursting operation (Atalah, 1998).

Condition Assessment of the Pipe Systems

According to the “ASCE Manual of Practice for Pipe Bursting Projects” (Najafi, 2006), the condition assessment of the pipe systems generally fall into two groups. The first group includes the existing pipe materials that are in serviceable condition but from a hydraulic

perspective, undersized and require upsizing, while the second group includes a pipe system that have some degree of deterioration or failure or leakage of pipe joints (Najafi, 2006).

High Density Poly Ethylene (HDPE)

Polyethylene pipe is a thermoplastic material made by the polymerization of ethylene gas. Thermoplastics can be heated, melted and re-solidified by cooling. This permits the manufacture of pipe by continuous extrusion through a die and the joining by fusion welding (Najafi, 2006). When British gas developed pipe bursting in the 1980s, they split low-pressure Cast Iron (CI) gas lines and inserted high-pressure Poly Ethylene pipes. British Gas reports that up to 2006 there has been about 9000 miles of PE pipes installed by bursting (Najafi, 2006). Poly Ethylene could be installed by any bursting process, pneumatics systems, static pull systems or hydraulic expansion systems, and it is common to install PE pipes up to 36". Poly Ethylene pipes are classified based on their Dimension Ratio (DR). DR 19 and DR 17 are the most commonly used in pipe bursting of gravity flow lines. The significant advantage of HDPE over the other pipe is the flexibility of the pipe, which is an important factor in pipe bursting under certain conditions.

Submittals

NASSCO (2003) lists the following submittals, training certificate by the pipe bursting system manufacturer declaring that the operator is completely trained in operating the equipment. Contractors, those who are not licensed by British Gas, should get the license before starting the project. Certifications from the pipe manufacturer regarding the training on handling and installing the new pipe should be submitted. Detailed description about the construction methodology and the layout plans, which include the sequence of construction activities, should be submitted. The construction methodology for the service reconnection pits and their location

and sizes are to be submitted. The complete information on material composition, physical properties and dimensions of the new pipe should be submitted. Traffic control plans, project schedule and contingency plans for unexpected situations should be submitted. These are the list of submittals by the contractor to the contracting authority before starting the project according to the Guideline Specifications. Some of the above specified submittals are not necessary for current practices, and hence we are updating the specifications by agreeing with instructions given by majority of specifications.

Summary

From the literature review, Pipe Bursting serves as an effective alternative for the traditional open cut method. Therefore, developing specification for the pipe bursting process will help contractors, engineers, owners and manufactures. This specification will consider all the information stated above and work closely with the industry experts to develop the Pipe Bursting Specifications further.

CHAPTER 3 - METHODOLOGY

Restatement of the Problem

Pipe bursting has been significantly developed since its inception in the 1970s. With the continuous development of this technique, earlier published specifications are incomplete and lacking proper allocation of risk and do not reflect the current state of the art. The problem of this study, therefore, is to develop a potential comprehensive specification that reflect the current state of pipe bursting.

Objectives of the Study

- To collect and extensively review the specifications, guidelines and other informations related to pipe bursting, which are available in the market place.
- To evaluate and compare the existing specifications with each other to identify the issues of agreement and disagreements among these specifications
- Develop a first draft specifications for pipe bursting using the good practice guidelines.

Collected Specifications

To achieve the first objective, an extensive literature review was conducted to identify existing specifications. Sixteen specifications from various departments of transportation, utility boards, and organizations involved in pipe bursting were collected. The details about the collected specifications are discussed below.

Washington Suburban Sanitary Commission - Pipe Bursting System

Washington Suburban Sanitary Commission (WSSC) in Maryland, published this specification in 2013. This specification includes the requirements to replace existing sanitary sewers using a pipe bursting system. This document was collected from the WSSC website under the General Conditions and Standard Specifications on 02/13/2015.

SKE Construction - Pipe Bursting Bid Specs

Pipe bursting bid specifications was published by SKE construction in 2012. SKE construction is one of the market leaders in Pre-Chlorinated Pipe Bursting. The pipe bursting bid specifications is divided into three parts, which was developed for Pipe Bursting of Potable Water Mains using Pre-Chlorinated Pipe. The first part consists of the general specifications, the second part consists of products specifications, and the third part consists of the execution specifications. This document was collected from the SKE construction website on 04/27/2015.

San Antonio Water System - Pipe Bursting/Crushing Replacement Process

San Antonio Water System (SAWS) in Texas, published this specification in 2008 for the replacement of sanitary sewers by pipe bursting in San Antonio, Texas. This specification includes the requirements to rehabilitate existing sanitary sewers by pipe bursting/crushing method, and it covers the pipe joining, manhole connections, connection of service laterals and stubs, point repairs, obstruction removals, television requirements, testing requirements, bypass pumping criteria, site restoration, erosion control requirements, and warranty requirements (San Antonio Water System, 2008). This document was collected on 04/28/2015 from the SAWS website under the construction specifications of the business center.

Orange County Utilities - Pipe Bursting of Gravity Sewers

Orange County Utilities in Florida, published this specification in 2012. This document provided the specifications for complete rehabilitation and upgrade of deteriorated wastewater gravity sewers by the pipe bursting system. This document was collected from the Orange County Government's website under the utilities department's technical specifications section on 03/15/2015.

Baton Rouge Projects - Section 811 Pipe Bursting

City of Baton Rouge in Louisiana, published the pipe bursting specifications in 2010. The section 811 - Pipe Bursting concentrated on gravity and force main applications with HDPE and Polyvinyl Chloride (PVC) pipe. This specification was collected on 3/15/2015 from the Baton Rouge projects website under the master specifications section.

B/CS Unified - Sanitary Sewer Pipe Bursting

The City of Bryan and City of College Station in Texas, together as B/CS Unified published this specifications in 2013. This specification consists of operations, equipment, methods, materials and required incidentals necessary for the replacement of wastewater mains by Pipe Bursting method (Bryan / College Station Unified, 2013). This specification was collected on 02/16/2015 from the Bryan / College Station Unified website under the sewer specifications section.

Denver Engineering Division - Construction Specifications

City and County of Denver Engineering Division in Colorado published this specification in 2014. The intention of this specification was to provide instructions for the replacement of existing wastewater pipelines and conduits by bursting or crushing the existing wastewater pipelines and replacing it with either the same size or larger diameter pipe (City and County of Denver Engineering Division, 2014). This document was collected from the Denver Government website on 02/16/2015. The pipe bursting specification is a part of the Wastewater Capital Projects Management Standards Construction Specifications.

Ontario Provincial and Standard Specification - Pipe Bursting

This specification is a part of the Ontario Provincial and Standard Specification in Ontario, Canada which was published in November 2009 and later reissued in November 2010.

This specification was developed for the municipal and provincial oriented contracts. The administration, testing, procedures, and practices reflected in this specification correspond to those used by many municipalities and the Ontario Ministry of Transportation. This specification was collected on 03/15/2015 from the Ontario Government's Ministry of Transportation's website under the section "Ontario Provincial Standards for Roads and Public Works."

Metropolitan Sewerage District of Buncombe County – Pipe Bursting

The Metropolitan Sewerage District of Buncombe County, North Carolina published this specification in 2010. This Pipe Bursting specification is a part of the technical specifications published by the County. This specification consists of the method and process for furnishing all labor, materials, tools, equipment and incidental work necessary to provide complete rehabilitation of existing sanitary sewers by pipe bursting (Metropolitan Sewerage District of Buncombe County, 2010). This specification was collected from the Metropolitan Sewerage District of Buncombe County website on 04/28/15.

Australasian Society of Trenchless Technology - Specifications for Pipe Bursting

Australasian Society of Trenchless Technology (ASTT) published the Sample Specifications for Pipe Bursting in September 2009 and later revised it in February 2010. The ASTT developed this specification in order to guide the industry users in Australia and New Zealand. This document also mentioned that this specification does not replace any existing standards or manuals and it is the user's responsibility to ensure that all relevant laws, standards and specifications are adhered to during the course of a works with use of Pipe Bursting. This specification was collected from the ASTT website on 03/15/2015.

Greater Peoria Sanitary District – Specifications - Pipe Bursting

Greater Peoria Sanitary District in Illinois published this specification in 2003. This specification concentrated on rehabilitation of existing sanitary sewers by pneumatic pipe bursting system. This specification was collected from the Greater Peoria Sanitary District website on 03/15/2015. The pipe bursting specification is a part of the engineering general specs published by the district.

Knoxville Utilities Board - Sanitary Sewer Pipe Bursting with HDPE

This specification is a part of the Knoxville Utilities Board Standards and Specifications, which was published in 2009 in Knoxville, TN. This specification intent to serve as instructions to replace the existing sanitary sewers by pipe bursting with High Density Polyethylene pipe. This specification was collected on 04/28/2015 from the Knoxville Utilities Board website under the standards and specifications section.

Oregon Department of Transportation – Pipe Bursting and Lining for Gravity Pipe

Oregon Department of Transportation published pipe bursting and lining for gravity pipe specifications in 2014. This specification was developed for lining existing gravity pipe by furnishing and installing, complete and in-place, High Density Polyethylene Pipe by pipe bursting method (Oregon Department of Transportation, 2014). This specification was collected on 03/15/2014 from the Oregon Department of Transportation's website under the highway documents section.

Commonwealth of Massachusetts– Guidelines for Pipe Bursting

Commonwealth of Massachusetts Department of Environmental Protection published this specification in 2009, which is the Bureau of Resource Protection Drinking Water Program. This guide was adapted from the Michigan Department of Environmental Quality documents.

Massachusetts Department of Environmental Protection recommends the public water systems intending to use pipe bursting to develop and implement written project requirements based on this guide. This document was collected on 04/28/2015 from the Government of Massachusetts website under the water department documents.

IPBA - Suggested Standard Specification for Pipe Bursting

This specification was prepared by International Pipe Bursting Association in January 2012 and peer reviewed by industry professionals. This supplemental sewer main specification is intended to address the installation of high-density polyethylene pipe for sewer main using pipe bursting methods and technology for sanitary sewer lines (IPBA, 2012). This document was collected from the National Association of Sewer Service Companies (NASSCO) website on 01/15/2015.

Louisiana Department of Transportation – Pipe Bursting/Crushing

Louisiana Department of Transportation (LDOT) published this specification in December 2005. Pipe Bursting/Crushing specification is a chapter in the Louisiana Administrative State Code 70 of the Transportation department. This document was collected from the Division of Administration, State of Louisiana website on 12/24/2014.

Evaluation and Comparison of the Collected Specifications

To evaluate and compare the existing specifications, a three-step procedure was developed:

Step 1: Through the analysis of the above 16 specs, the main topics covered by majority of the specifications were identified. These topics contain instructions that serve as requirements for the contractor in order to meet quality standards of the project. The main topics identified are: General introduction, Definitions, Reference Standards, Qualifications of the contractor,

Submittals, Pipe Fusion, Methods of Pipe Bursting, Testing and Inspection, Locating Utilities and Service Connections, Bypassing the Flow, Traffic Control Plans, Service Reconnection, and Site Restoration.

Step 2: Each specification was then compared with the identified topics and instructions to determine if the specifications agree or disagree on these instructions. Where majority of specifications agree on a specific instruction, the instruction is identified as an accepted agreement. The instruction is then compared with current industry guidelines to determine its conformity to the current state of the art. In the case of a disagreement, the industry guidelines are used to update and to resolve the disagreement. The issues arising from these disagreements are resolved to reflect general application of the technique and not tailored to a specific project. These can then be adapted, modified and applied to any project by the user.

Step 3: Based on the agreements and the resolved issues from the instructions, a draft specification was developed.

CHAPTER 4 - FINDINGS

This chapter presents findings from the comparison of the specifications with the identified topics. Sixteen specifications from several departments of transportation, utility boards, and organizations involved in pipe bursting were collected. With the help of these specifications, the draft specification was developed. Various disagreements among the existing specifications were resolved according to current good practice guidelines. The results presented below are the contents of the pipe bursting specifications in addition to the agreements and disagreements on each instruction.

General

This topic covers the general introduction about the specification. As this is a general topic, all the specifications covered it and there were no disputes to solve. The specification covers the methodology and procedures to be followed for all labors, materials, tools, equipment, and incident work related to the pipe bursting process.

Definitions

Technical terms that have been used in the specifications need to be explained and defined within the context of the specifications. Six out of the sixteens specifications covered the definitions. The terms defined in the studied specifications varied depending upon the technical terms used in the specification. According to Orange County Utilities (2012), Pipe Bursting is a process by which the bursting unit splits and/or fractures the existing pipe while simultaneously installing a new pipe of the same or larger size into the annulus created by the forward movement of the bursting tool. Pipe Bursting is an alternative to replacing of underground infrastructure by open cutting (Orange County Utilities, 2012). According to Washington Suburban Sanitary Commission (2013), Host Sewer Main is defined Existing pipeline subject to pipe bursting

system made of vitrified clay, asbestos cement, polyvinyl chloride (PVC), cast iron, concrete, steel or lined pipe, and Renew Lateral is defined as Replace service lateral in public space or easement by pipe bursting, or if necessary by excavation and replacement (Washington Suburban Sanitary Commission, 2013). According to Australasian Society for Trenchless Technology (2009), CCTV is the Closed Circuit Television, which is defined as the use of video cameras to visually inspect the works. Often used where man entry not feasible/ possible, and Contingency Plan is defined as A plan for backup procedures, emergency response, and post disaster recovery (Australasian Society for Trenchless Technology, 2009).

Reference Standards

While looking at the specifications, twelve out of the sixteen specifications (Table 2 & 3) stated that the specifications of ASTM D 3350 should be followed for the polyethylene pipe and fitting materials. It is also expected that the pipe should be homogeneous throughout and should be free of cracks, holes, blisters, foreign material or any other fault related to the pipe. However, the only difference is that six out of the sixteen specifications concentrated on both PVC and HDPE pipes; however, the focus of this study was only on HDPE. According to ten out of the sixteen specifications, HDPE should meet all the requirements of ASTM F 714 and it is important that all the pipes used should be made from virgin material and no reformed materials can be used unless they are from the pipe manufacturer's own production of same formulation. According to two out of the sixteen specifications, the butt fusion process should follow ASTM D 3621. According to seven out of the sixteen existing specifications, the high-density high molecular weight polyethylene compound should follow ASTM D 1248; Standard Dimension Ratio (SDR) 17 should be used in case of pressure or gravity pipe and SDR 21 can be used where high tensile forces are not expected.

Qualifications of the Contractor

The qualifications of the contractor is the topic in which the collected specifications disagreed. Eleven out of the sixteen specifications (Table 2 & 3) required the contractor to be certified by the pipe bursting equipment manufacturer, and the operator involved in the bursting process should be trained and certified to operate the bursting equipment. NASSCO (2003) stated that the British Gas company should license the contractors to execute the bursting process.

Table 2 : Summary comparison of the first eight collected Specs.

Abbreviations: AG–Agree,

NM–Not Mentioned,

X- Topic not available

Contents	Washington Suburban	SKE Cons, PB bid	San Antonio Water	Orange County	Baton Rouge	B/CS Uniteds	Denver Public	Ontario Provincial	Total
Reference Standards					X			X	
ASTM D 3350	AG	AG	AG	AG		AG	AG		12
ASTM F714	AG	AG	AG	NM		AG	AG		10
ASTM D 1248	NM	NM	AG	NM		AG	AG		7
SDR Minimum 17	AG	AG	AG	NM		NM	NM		7
Qualification of Con.		X	X				X	X	
Years	NM			4	NM	NM			
Distance	NM			25000 ft	NM	NM			
Certification	AG			AG	AG	AG			10
Submittals		X							
Site layout plans	AG		NM	AG	NM	NM	NM	NM	7
Contractor's experience	AG		NM	AG	AG	AG	NM	NM	9
Bursting equip. specs	AG		NM	AG	AG	AG	NM	NM	11
Bypass pumping plan	AG		NM	AG	AG	AG	NM	NM	9
Lubricant	AG		NM	NM	AG	NM	NM	NM	4
CCTV inspection	AG		AG	AG	AG	AG	AG	AG	14
Pipe fusion									
Certification needed	AG	NM	AG	AG	AG	AG	Con is res.	AG	12
Testing and inspection									
Pre and Post CCTV Inspection	AG	NM	Pre-Owner Post- Con	AG	AG	AG	AG	AG	12
Pressure and low pressure test	AG	AG	AG	AG	NM	NM	NM	NM	7
Free from cracks and defects	AG	NM	AG	AG	AG	AG	AG	NM	12
AWWA, disinfection	NM	AG	NM	NM	NM	NM	NM	NM	2
ASTM standards	AG	AG	AG	NM	NM	AG	NM	NM	6
Sag or hump removal	AG. Point rep.	NM	NM	Con. AG	AG	AG	NM	NM	5

Abbreviations: AG–Agree,

NM–Not Mentioned,

X- Topic not available

Contents	Washington Suburban	SKE Cons, PB bid	San Antonio Water	Orange County	Baton Rouge	B/CS Uniteds	Denver Public	Ontario Provincial	Total
Smoke test	NM	NM	AG	NM	NM	NM	NM	NM	2
Deflection test	NM	NM	AG	NM	NM	NM	NM	NM	2
Locating utilities and service con		X		X		X	X	X	
One call agency	NM		NM		NM				2
Contractor should verify	AG		AG		AG				6
Bypassing the flow	X							X	
Contractor is responsible		NM	AG	AG	AG	AG	AG		9
Outage timings		8-6 M-F	NM	NM	NM	NM	Not more than 24 hrs		
Spills. Contractor responsible		NM	AG	AG	AG	AG	AG		9
Traffic control plans	X		X			X	X	X	
Contractor responsible		NM		NM	NM				2
MUTCD, municipalities manual		NM		NM	AG				3
Timing of work		8-6 M-F		NM	NM				
OSHA standards		NM		AG	AG				4
Service reconnections									
Relaxation time	4 hours	Manufac.	12 hours	4 hours	12	4	Manufac.	Manufac.	9
Saddle connections	Heat or electro	Electro	NM	Inserta-Tee	Electro	NM	Heat	NM	6

Table 3 : Summary comparison of the second eight collected specs

Abbreviations: AG–Agree,

NM–Not Mentioned,

X- Topic not available

Contents	Technical specs	ASTT - Specs	Peoria- PB spec	Knoxville utilities	Section 00412 PB	Massachusetts	NASSCO, IPBA	Louisiana DOT	Total
Reference Standards		X	X						
ASTM D 3350	AG			AG	AG	AG	AG	AG	12
ASTM F714	AG			AG	AG	AG	AG	NM	10
ASTM D 1248	NM			AG	AG	NM	AG	AG	7
SDR Minimum 17	NM			NM	AG	AG	AG	AG	7
Qualification of Con.		X						X	
Years	5		NM	NM	3	4	3		
Distance	50000		NM	NM	NM	30000	50000		
Certification	AG		AG	AG	AG	AG	AG		10
Submittals						X			
Site layout plans	AG	NM	AG	AG	AG		AG	NM	7
Contractor's experience	AG	AG	AG	AG	NM		AG	NM	9
Bursting equip. specs	AG	AG	AG	AG	AG		AG	AG	11
Bypass pumping plan	AG	AG	AG	AG	AG		NM	NM	9
LUBRICANT	AG	NM	NM	AG	NM		NM	NM	4
CCTV inspection	AG	AG	AG	AG	AG		AG	AG	14
Pipe fusion								X	
Certification needed	AG	NM	AG	AG	AG	AG	AG		12
Testing and inspection									
Pre and Post CCTV inspection	Pre- Owner. Post-Con	AG	AG	AG	AG	NM	AG	AG	12
Pressure and low pressure test	NM	NM	NM	AG	AG	AG	NM	NM	7
Free from cracks and defects	AG	AG	NM	AG	AG	NM	AG	AG	12
AWWA, disinfection	NM	NM	NM	NM	NM	AG	NM	NM	2
ASTM standards	AG	AG	NM	NM	NM	NM	NM	NM	6
Sag or hump removal	NM	NM	NM	NM	AG	NM	AG	AG	5
Smoke test	NM	NM	AG	NM	NM	NM	NM	NM	2
Deflection test	NM	NM	AG	NM	NM	NM	NM	NM	2

Abbreviations: AG–Agree,

NM–Not Mentioned,

X- Topic not available

Contents	Technical specs	ASTT - Specs	Peoria- PB spec	Knoxville utilities	Section 00412 PB	Massachusetts	NASSCO, IPBA	Louisiana DOT	Total
Locating utilities and service con	X	X	X		X	X			
One call agency				NM			AG	AG	2
Contractor should verify				AG			AG	AG	6
Bypassing the flow		X		X			X		
Contractor is responsible	AG		AG		AG	NM		AG	9
Outage timings	8 hours		NM		NM	8-6 M-F			
Spills. Contractor responsible	AG		AG		AG	NM		AG	9
Traffic control plans			X	X	X		X		
Contractor responsible	NM	AG				NM		AG	2
MUTCD, municipalities manual	NM	AG				NM		AG	3
Timing of work	NM	NM				8-6 M-F		Day light M-F	
OSHA standards	AG	NM				AG			4
Service reconnections									
Relaxation time	4 hours	Manufac.	Manufac.	Manufac.	12	Manufac.	Manufac.	Manufac.	9
Saddle connections	Electro	NM	Electro	Electro or inserta	Electro	Electro	Electro or inserta	NM	6

Five out of sixteen existing specifications have specified the experience of the contractor, which ranges from three to five years and the installed pipe distance ranges from 25,000 to 50,000 feet under similar difficulty level, scope, and size.

The need for the bursting manufacture to certify the contractor and train their operators may have been appropriate in the early days of pipe bursting. Currently as the industry matured, there many contractors who own their systems and train their operators. The equipment manufacturer usually train the contractor staff when they purchase a new system. Adding paper work, time, and cost that do not add significant value is not needed. As stated earlier the Britch Gas patent expired, and therefore, being royalty and holding the owner harmless on the royalty payement becomes irrelevant.

Pipe bursting jobs have different levels of difficulties, challenges, and risks; therefore, having a set and fixed prequalification requirements for all jobs increases the cost of less difficult and risky jobs and add significant additional risk on challanging jobs. Accordingly, it is recommended that the level of difficulties, challenges, and risks determine the level of required pre-qualifications of the contractor. The contractor prequalifications can be measured by the installed footage of pipe bursting in similar conditions.

Submittals

Submittals are the list of documents, samples, procedures, etc. that should be submitted by the contractor to the owner for approval prior to the start of the construction. Four out of the sixteen specifications (Table 2 & 3) expected the contractor to submit the lubrication method. Thirteen out of the sixteen specifications agreed on submitting the certification of training for operating butt fusion equipment. Fourteen out of the sixteen specifications agreed that the contractor should submit pre and post CCTV inspection. According to seven out of the sixteen

specifications, the following submittals are required: site layout plans that show the location of the insertion and pulling shafts, dimensions of shafts, safety and communication plan, storage space to store and lay the new pipe. Eleven out of the sixteen specifications stated the pipe bursting equipment manufacturer's specifications of the selected bursting method. Nine out of the sixteen specifications stated the following: all the documents related to contractor's experience, bypass pumping plan, dewatering plan, shoring design for all excavations, service reconnection plan, pipe fusion process, site restoration and clean-up plans, traffic control plan, project schedule and contingency plan should be submitted.

Pipe Fusion

Pipe fusion is the method of joining HDPE and fusable PVC pipes. According to all the 16 specifications, the butt-fusion method should be used to assemble and join the HDPE and fusable PVC pipes at the site in order to provide a leak proof joint. According to thirteen out of the sixteen specifications (Table 2 & 3), the person involved in the fusion process should be experienced and certified by the fusion equipment manufacturer and/or trained to operate the equipment. Whereas, three out of the sixteen specifications did not specify about the qualifications of the fusion machine operator.

Methods of Pipe Bursting

The pipe bursting methodology is a very common topic that was covered in ten of the studied specifications. According to ten out of the sixteen specifications, the bursting unit should generate sufficient amount of force to burst the existing pipe. Furthermore, the bursting equipment manufacturer's recommendations should be followed in order to determine the tool size, which is a function of the diameter of the pipe and the degree of upsizing. In addition, the pipe-bursting tool shall be pulled through the old pipe by a winch or rod located at the pulling

pit. Lastly, the bursting head shall pull the polyethylene (PE) pipe along with it as it moves forward.

Testing and Inspection

The existing pipe and the replacement pipe are subjected to testing and inspection. Concerning the disagreements, four out of the sixteen specifications (Table 2 & 3) stated that if any obstructions are identified during the inspection of the old pipe that may potentially prevent the bursting of the pipe and it cannot be removed by cleaning equipment, a point repair should be made and additional payment will be made. Two out of the sixteen stated the following: smoke test and deflection test should be performed in order to ensure the integrity of the new pipe, for Potable water installations additional disinfection and testing requirements should be followed as per the standards of AWWA C651 and the utility owner.

Concerning the agreements among the specifications, twelve out of the sixteen specifications stated that the contractor should conduct a pre and post construction CCTV inspection and should submit a copy to the owner. In contrast, two out of the sixteen specifications stated that the owner will do the Pre-Construction CCTV inspection and a copy will be given to the contractor, and then the contractor should do a Post-Construction CCTV inspection, and a copy has to be submitted to the owner. According to seven out of the sixteen specifications, during the CCTV inspection, if sags or humps are identified in gravity lines, it is the contractor's responsibility to remove them. Seven out of the sixteen specifications agreed on the following: a low-pressure air test at 3.5 psi below the ground water pressure should be conducted in the gravity sewer lines to ensure the integrity of the pipe and its connections, and the pressure test at specified testing pressure for the pressure class of the pipe should be conducted for pressure lines such as water, gas, and force main.

In six out of the sixteen specifications, the following are stated: tests should be conducted to verify the materials used is in accordance with the applicable ASTM standards mentioned in the reference standards section, the new pipe should be free from visible cracks, holes, foreign material, blisters, or other deleterious faults as specified in the materials references.

Locating Utilities and Service Connections

The location of the nearby utilities and service connections should be verified prior to any excavation made for construction purposes. Regarding the disagreements among the studied specifications, according to Knoxville Utilities Board (2009), the minimum clearance of the bursting head from other utilities is 2 feet. Whereas, five out of the sixteen specifications (Table 2 & 3) have stated that it depends upon the size of the bursting head and did not specify any distance. Six out of the sixteen specifications stated that the contractor should verify the location of all the nearby utilities prior to bursting whereas the rest of the studied specifications did not specify any details about the location of utilities and service connections. According to six out of the sixteen specifications, an excavation can be made in order to locate and expose the existing utility lines in the zone of influence and verify their clearance from the pipe to be burst. Two out of the sixteen specifications stated that, before excavating for any reason, the contractor should contact the One Call agency in order to locate the existing utilities.

Bypassing the Flow

Bypassing the flow is temporary diverting the flow in the existing service line to a temporary line until the new pipe is installed. There was not much disagreement among the specifications for bypassing the flow as this process is full responsibility of the contractor, and so the contractor selects the most efficient method to bypass the flow. Regarding the disagreements, four out of the sixteen specifications (Table 2 & 3) have specified limits on the outage duration

that ranges from 8 – 24 hours, but the rest of the specifications did not specify the outage duration. Regarding the agreements, nine out of the sixteen specifications state that the contractor is held completely responsible for bypassing of the flow. It is the contractor's responsibility to ensure that the bypass lines have adequate capacity and size to handle all the flows and prepare an emergency backup plan to make sure (a) there is no flow interruption to the ultimate users, and (b) the bypass pipes and fittings should have enough strength to withstand the surge pressure of the flow. According to nine out of the sixteen specifications; the contractor should ensure that (1) there is no spills or overflows at any time and (2) if there is an overflow or spills due to the work performed, the contractor should take appropriate actions, such as stop the spillage, clean it, disinfect the affected area and notify the owner as soon as possible for further inspection.

Traffic Control Plans

Regarding the disagreements among the studied specifications on the traffic control, SKE Construction (2012) and Massachusetts Department of Transportation (2009) specified the timing for lane closure as 8 AM- 5 PM, Monday to Friday. Louisiana Department of Transportation (2002) specified that the lane closure should not be between 7 AM – 9 AM and 3 PM – 6 PM and the rest of the specifications did not specify any details about the lane closures. Regarding the agreements, four out of the sixteen studied specifications (Table 2 & 3) agreed on the following: the traffic control plans should follow the traffic control manuals of municipalities and road owners, Occupational Safety and Health Administration (OSHA) standards should be followed while controlling the traffic during construction, and whenever a lane closure is required during the construction, the contractor should obtain permission from appropriate authorities. Three out of the sixteen specifications stated the following: Manual on Uniform

Traffic Control Devices (MUTCD) published by U.S. Department of Transportation's Federal Highway Administration should be followed, and the disturbed traffic should be restored to original condition as soon as the work is completed. Service Reconnection

Before reconnecting the service, the newly installed pipe should be relax to for a certain period to allow the HDPE expands reach final installation length and recover from installation stresses. Regarding the disagreements, seven out of the sixteen studied specifications (Table 2 & 3) have specified the relaxation period, which ranges from four to twelve hours. However, nine out of the sixteen specifications have asked the contractor to follow the pipe manufacturer's recommended time for the relaxation period. Regarding the agreements, ten out of the sixteen specifications stated the following: the saddles made up of materials compatible to the pipe should be connected in order to provide a leak free joint, Electro fusion saddles or Inserta-Tee connection shall make service lateral connections with the approval of the owner or as specified in the contract document.

Site Restoration

The site restoration is a topic covered by most of the specifications. It is the contractor's responsibility to restore all disturbed surface areas, due to construction, to their original condition or as specified in the contract documents. The contractor should restore all the launching pits and pulling pits to the original condition before excavation or as specified in the description of work. Prior to backfilling of lateral and launching pits, the contractor shall ensure that the new pipe is properly supported and on the required grade. Appropriate materials according to the contract documents should be used to support the new pipe and to avoid sagging after backfill and compaction.

CHAPTER 5 - SUMMARY AND DISCUSSIONS

Summary

In summary, the research study collected sixteen pipe-bursting specifications available in the market place and conducted an extensive literature review on existing specifications and guidelines. The agreements and disagreements among the specifications were used in developing a draft specification. The various disagreements among the specifications were resolved based on the current good practices guidelines. The major aspect of the specifications was to allocate the responsibility of tasks to the entity best positioned to manage these responsibilities without bias. This specification can be developed further with the help of peer reviewing by industry experts.

Discussions

The discussions followed are the agreements among the majority of the existing specifications and implementation of the majority of agreements in the draft specification.

Reference Standards

Regarding the reference standards, the American Society for Testing and Materials (ASTM) standards and the guidance from Plastic Pipe Institute (PPI) should be followed for materials used in the pipe bursting process. According to majority of the specifications, the materials used for construction purposes should follow ASTM D 3350, ASTM F 714, ASTM D 1248, a SDR 17 or thicker wall should be used in gravity application and low pressure application like low and medium pressure gas lines. The HDPE pipe for potable water are SDR 13 and less, and these pipes that are able to withstand the bursting stresses.

Qualifications of the Contractor

The qualifications of the contractor should depend upon the level of difficulty and risks associated with the project. A specific number of years or installed footage needs to be

compatible with the level of challenge and risk associated with the project. The owner decides the experience level of the contractor, which will be appropriate for the level of difficulty and risk associated with the specific project. Specifying higher qualifications might reduce competition facilitating an increase in the bid price. For example, for a small pipe replacement of the same size as the existing pipe in less risky location without nearby pipelines and structures, there is no need for a highly experienced contractor as the difficulty level and the risk associated with the project is low. On the other hand, in case of upsizing larger pipes in risky and challenging conditions such as high traffic volume with nearby pipelines and structures, there is a need for experienced contractor. So the proposed specifications does not mention any specific proof of experience but a general statement on the level of experience of the contractor which varies according to the risks and challenges associated with the project. The British Gas patent has expired in 2005, and hence, there is no need for the contractor to be licensed or permitted by British Gas.

Submittals

According to majority of the specifications, the contractor should submit the contractor's experience, certification of the fusion equipment operator, site layout plans, pipe bursting equipment manufacturer's specifications for the method selected and CCTV inspection. Also, the pipe fusion process, shoring design, dewatering plan, bypass pumping plan, service reconnection plan, traffic control plan, contingency plan, project schedule, site restoration and clean-up plan should be submitted to the owner for approval prior to start of construction. When an excessive ground movement is expected near the existing structures, the contractor should submit the ground-monitoring plan and get it approved. The lubrication is not necessary in all the cases; however, lubrication may be needed in certain circumstance such as long runs in expansive soils.

Pipe Fusion

According to the majority of the specifications, the polyethylene pipe should be assembled and joined at site using butt-fusion method and the person operating the fusion equipment should be trained and/or certified by the fusion equipment manufacturer. Therefore, the proposed specification agreed with the majority and implemented the instructions.

Methods of Pipe Bursting

Based on the agreements by majority of the specifications, the bursting unit should generate sufficient amount of force to burst the existing pipe. The contractor should consider the bursting equipment manufacturer's recommendations to determine the tool size, which is a function of the diameter of the pipe and the degree of upsizing. From the pulling pit, the pipe-bursting tool shall be pulled from the pulling pit through the old pipe by a winch or a rod. As the bursting head moves forward, the polyethylene (PE) pipe shall be pulled along with it. As the methodology of pipe bursting stated by the majority of specifications reflects the current state of art, the instructions were effected in the draft specifications.

Testing and Inspection

Based on the agreements among the specifications, a low-pressure air test at 3.5 psi should be conducted in case of gravity sewers, and pressure test at 9 psi in case of water, gas and force mains to ensure the integrity of the piping systems. Additional disinfection and testing requirements should be followed according to AWWA 651 in case of water installations. The contractor should conduct a CCTV inspection and submit a copy to the owner. If sags or humps are identified in case of gravity lines during the CCTV inspection, it is the contractor's responsibility to remove them; whereas in case of steep lines, the need for removal may not be needed. If in case the obstructions are mentioned in the contract documents, it is part of the scope

of work that the contractor should have included in the bid. Therefore, the owner will not pay additional expense for point repair. The applicable ASTM standards mentioned in the reference standards should be tested and verified and inspection should be done to verify that the new pipe is free from visible cracks, holes, foreign material, blisters, or other deleterious faults as specified in the materials references. Hence, the draft specification implemented the majority of agreements.

Locating the Utilities and Service Connections

Based on the majority of agreements among the specifications, the contractor should verify all the utilities prior to pipe bursting by excavating. Before excavating for any reason, the One Call Agency should be contacted to verify the location of the utilities. The contractor should be aware of all the obstructions and not completely depend on the owner. While excavating with machines, it is safer to excavate the last 6” manually as it reduces the potential risk of damaging the utilities.

Bypassing the Flow

Based on the agreements among the majority of the specifications, the outage timings are not specified as it may vary depending upon the type of job. It is recommended that the owner specify the allowable outage duration, which vary from one project to another. It is the contractor’s responsibility to bypass the flow without spills or overflows at any time. In case of any spills or overflows, the contractor should stop the overflow, clean the spillage and disinfect the affected area as soon as possible. The contractor should develop an emergency backup plan to ensure that there is no interruption in the flow.

Traffic Control Plan

Based on the majority of agreements among the specifications, the contractor must follow the traffic control manuals by municipalities and road owners. Manual of Uniform Traffic Control Devices (MUTCD) and OSHA standards should be followed while controlling the traffic. In case of lane closure, permission should be obtained from the appropriate authorities. As soon as the construction is over, the traffic should be restored to original condition. The lane closure timings cannot be generalized as the timing of the work depends upon the type of job, and there are various factors to be considered before deciding the timing of work.

Service Reconnection

The HDPE pipe should be left free for the relaxation period specified by the pipe manufacturer prior to reconnecting the service lines. The relaxation period for the pipe can be found in the pipe manufacturer's instructions. Lateral connections should be done by saddles made up of materials compatible with the pipe and fused by Electro Fusion Saddles or Inserta-Tee or as specified in the contract document.

Conclusions

From this study, it can be concluded based on the majority of agreements among the existing specifications. The disagreements among the specification in Appendix A was drafted based on the above mentioned comparisons and the current state of art. The draft specification has developed a complete specification along with proper allocation of risks, which reflects the current practice of pipe bursting.

Further Research

To improve this specification further, a peer reviewed evaluation and critique by the industry experts should be conducted, and based on the feedbacks, the specification can be

developed further. A committee consisting of industry experts who represent the interests of the owner, contractor, engineer, manufacturer and academia can be set up to ensure that the final specification is balanced and allocate the responsibilities and risks appropriately to an entity that is best qualified to handle the responsibility. The appropriate allocation of responsibility is one of the major challenges while developing the specifications.

References

- Atalah, A. (1998). The Effect of Pipe Bursting on Nearby Utilities, Pavements and Structures. Ruston, LA: Trenchless Technology Center.
- Atalah, A. (2006). The Safe Distance between Large-Diameter Rock Pipe Bursting and Nearby Buildings and Buried Structures. ASCE Journal of Transportation Engineering.
- Atalah, A. (2008). Pipe Busting. In Plastic Pipe Institute Handbook.
- Australasian Society for Trenchless Technology. (2009). Specification for Pipe Bursting. Retrieved from www.astt.com.au: http://www.astt.com.au/images/uploads/ASTT_-_Specification_for_Pipe_Bursting.pdf
- Betts, G. (2000). Construction Documentation Specifications. American Institute of Architects(AIA).
- Bryan / College Station Unified. (2013). Sanitary Sewer Pipe Bursting. Retrieved from www.bcsunified.net: www.bcsunified.net/2009_Files/Specs/Sewer/333113.pdf
- Ceresana. (2014). Market study: Polyethylene - HDPE (3rd edition). Ceresana Research.
- City and County of Denver Engineering Division. (2014). Pipe Bursting. Retrieved from www.denvergov.org:
http://www.denvergov.org/Portals/711/documents/SCS%2010_20.pdf
- City of Baton Rouge. (2010). Pipe Bursting Specifications. Retrieved from www.brprojects.com:
http://brprojects.com/SSOProgram/Documents/Design/specs/Section_811_Pipe_Bursting.pdf
- Greater Peoria Sanitary District. (2003). Specifications - Pipe-Bursting. Retrieved from www.gpsd.dst.il.us: <http://www.gpsd.dst.il.us/SEC79.pdf>

- Hashemi, S. B. (2008). Construction Cost of Underground Infrastructure Renewal: A Comparison of Traditional Open Cut and Pipe Bursting Technology.
- Howell, N. (1995). The PE pipe Philosophy for Pipeline Renovation. No-Dig International. Dresden, Germany: ISTT, UK.
- Howell, N., & Gowdy, F. (1999). Improving Pipebursting Capabilities. NoDig International.
- IPBA. (2012). Guideline for Pipe Bursting. Owings Mills, MD: NASSCO.
- IPBA. (2012). Suggested Standard Specification for Pipe Bursting Gravity Sewer Mains with HDPE Pipe. Retrieved from NASSCO:
http://www.nassco.org/publications/specs/pipebursting_11Jan2013.pdf
- Knoxville Utilities Board. (2009). Sanitary Sewer Pipe Bursting with High-Density Polyethylene Pipe. Retrieved from www.kub.org:
[http://www.kub.org/prc/prcspecs.nsf/a2f228d1507aea5b8525750b00585495/6ada070d8e73ba4f85257515007b51af/\\$FILE/02955%20%20Sanitary%20Sewer%20Pipe%20Bursting%20with%20HDPE%20v2.pdf](http://www.kub.org/prc/prcspecs.nsf/a2f228d1507aea5b8525750b00585495/6ada070d8e73ba4f85257515007b51af/$FILE/02955%20%20Sanitary%20Sewer%20Pipe%20Bursting%20with%20HDPE%20v2.pdf)
- Louisiana Department of Transportation. (2005). Pipe Bursting/Crushing. Retrieved from www.doa.la.gov: <http://www.doa.la.gov/osr/lac/70v01/70v01.pdf>
- Massachusetts Department of Environmental Protection. (2009). Guidelines For Pipe Bursting of Potable Water Mains Using Pre- and Post-Chlorinated HDPE Pipe. Retrieved from www.mass.gov: <http://www.mass.gov/eea/docs/dep/water/laws/i-thru-z/pipebrst.pdf>
- Metropolitan Sewerage District of Buncombe County. (2010). PIPE BURSTING. Retrieved from www.msdbc.org:
<http://www.msdbc.org/documents/sewerextdev/techspecs/item7pipebursting.pdf>

- Najafi, M. (2006). ASCE Manual of Practice for PipeBursting Projects. American Society of Civil Engineers.
- NASSCO. (2003). Guideline Specification for the Replacement of Mainline Sewer Pipes By Pipe Bursting. International Pipe Bursting Association.
- Ontario Ministry of Transportation. (2010). Construction Specification For Pipeline and Conduit Instalation by Pipe Bursting. Retrieved from www.raqsb.mto.gov.on.ca:
<https://www.raqsb.mto.gov.on.ca/techpubs/ops.nsf/d37f5a16d8174ffa85256d130066857f/e2b07b38f68f8b728525706e00675980?OpenDocument>
- Orange County Utilities. (2012). Pipe Bursting for Gravity Sewers. Retrieved from www.ftp.ocfl.net:
<ftp://ftp.ocfl.net/divisions/Utilities/pub/C%20I%20P/Master%20CIP%20Technical%20Specifications/02776%20Pipe%20Bursting%20of%20Gravity%20Sewers.doc>.
- Oregon Department of Transportation. (2014). Pipe Bursting and Lining for Gravity Pipe. Retrieved from www.oregon.gov: www.oregon.gov/odot/hwy/.../docs/.../section_00412-final.doc
- Plastic Pipe Institute. (2008). High Density Poly Ethylene Pipe Systems - Meeting the challenges of 21st century. Retrieved from www.plasticpipe.org:
https://plasticpipe.org/pdf/high_density_polyethylene_pipe_systems.pdf
- Rameil, M. (2007). Handbook for Pipe Bursting Practice. Vulkan-Verlag GmbH.
- Rogers, C., & Chapman, D. (1995). Ground Movement Caused by Trenchless Pipe Installation Techniques. Proc. of Transportation Research Board.
- Rosen, H. J. (1999). Construction specifications writing. New York: John Wiley & Sons, Inc.

- San Antonio Water System. (2008). Reconstruction of Sanitary Sewer by Pipe Bursting/Crushing Replacement Process. Retrieved from www.saws.org:
http://www.saws.org/business_center/specs/constspecs/
- Simicevic, J., & Sterling, R. L. (2001). Guidelines for Pipe Bursting. Trenchless Technology Center (TTC).
- SKE Construction. (2012). Pipe Bursting Bid Specifications. Retrieved from www.ske1.net: <http://ske1.net/bid-specs/>
- Topf, H. (1991; 1992). XPANDIT Trenchless Pipe Replacement. North American No-Dig. Kansas, MO: NASTT.
- TT-Group, M. R. (2009). Blast from the past - a history of pipe bursting . Trenchless International.
- Tucker, R. (1987). "Hydraulic Pipe Bursting Offers a New Dimension. No-Dig international. London, UK: ISTT.
- Washington Suburban Sanitary Commission. (2013). Standard Specifications Section 02958 Pipe Bursting System. Retrieved from www.wsscwater.com:
<https://www.wsscwater.com/business--construction/regulatory--licensing-services/general-conditions--standards-sp.html>

APPENDIX A

SPECIFICATIONS OF PIPE BURSTING USING HIGH DENSITY POLYETHYLENE PIPE (HDPE)

1) General:

This specification covers the methods and procedures for furnishing all labor, materials, tools, equipment and incidental work required for replacement of existing pipe using pipe-bursting process.

2) Definitions:

- Butt fusion - The joining of two pieces of plastic or metal pipes or sheets by heating the ends until they are molten and then pressing them together to form a homogeneous bond.
- Contingency plan – Backup plans for emergency cases and post disaster recovery.
- Dewatering – Process of lowering of ground water level.
- The Standard Dimension Ratio (SDR) - SDR is the ratio of wall thickness to the outside diameter of the pipe. The SDR in the HDPE is one of the major aspects to be considered as it determines the ability of the pipe to withstand the installation forces and service pressure.

3) Reference Standards:

- ASTM D 3350 – Specification for Polyethylene Pipe and Fitting Materials.
- HDPE should meet all the requirements of ASTM F 714.
- ASTM D 1248 - High Density high molecular weight polyethylene compound.

- All pipes should be manufactured from virgin material. No reformed materials can be used unless they are from the pipe manufacturer's own production of same formulation.
- The pipe shall be homogeneous throughout and shall be free of visible cracks, holes, foreign material, blisters, or other deleterious faults.
- The SDR 17 or thicker wall should be used in gravity application and low pressure application like low and medium pressure gas lines.
- The HDPE pipe for potable water are SDR 13 and less, and these pipes that are able to withstand the bursting stresses.

4) Qualifications of the Contractor:

- The qualifications of the contractor should depend upon the level of difficulty and risk associated with the project.
- A specific number of years of experience or installed footage needs to be compatible with the level of challenge and risks.

5) Submittals:

- The documentation proving the contractor's experience under similar projects if required
- Certification by the fusion equipment manufacturer that the person involved in fusion process is trained.
- The site layout plans which shows the location of the insertion and pulling shafts, dimensions of shafts, safety and communication plan, storage space to store and lay the new pipe, and so forth.
- The bursting equipment manufacturer's specification for the selected bursting system.

- CCTV inspection.
- Pipe fusion process.
- Shoring design for all the excavations.
- Bypass pumping plan.
- Service reconnection plan.
- Ground movement monitoring plan.
- Dewatering plan.
- The site restoration and clean-up plans.
- Traffic control plan.
- Project schedule.
- Contingency plan.

6) Pipe fusion:

- The polyethylene pipe shall be assembled and joined using the butt-fusion method at the site to provide a leak proof joint.
- The fusion equipment manufacturer should certify the person involved in fusing and/or successfully trained to carry out the process.

7) Methods of Pipe Bursting:

- The bursting unit should generate sufficient amount of force to burst the existing pipe. Refer to the bursting equipment manufacturer's recommendations to determine the tool size, which is a function of the diameter of the pipe and the degree of upsizing.
- The pipe-bursting tool shall be pulled through the old pipe by a winch or rod located at the pulling pit. The bursting head shall pull the polyethylene (PE) pipe along with it as it moves forward.

8) Testing and Inspection:

- A low-pressure air test at 3.5 psi greater than the ground water pressure to ensure the integrity of the piping system and its connections in gravity sewer lines.
- A pressure test at specified testing pressure for the pressure class of the pipe should be performed for newly installed pressure pipes such as water, gas, and force main.
- The newly installed pipe should be visibly free from defects, which may affect the integrity or strength of the pipe. For water installations, additional disinfection and testing requirements should be followed as per the standards of AWWA C651 and the utility owner.
- The contractor should conduct a CCTV inspection and submit a copy to the owner.
- Tests should be conducted to verify the materials used is in accordance with the applicable ASTM standards mentioned in the reference standards section.
- During the CCTV inspection, if sags or humps are identified in a flat or gravity lines, it is the contractor's responsibility to remove them.

9) Locating Utilities and Service Connections:

- The contractor should verify the location of all the utilities prior to bursting. In order to verify the location of the existing utilities, an excavation can be made to locate and expose the existing utility lines in the zone of influence and verify their clearance from the pipe to be burst.
- Before excavating for any reason, the contractor should contact the One Call Agency in order to locate the existing utilities.

10) Bypassing the Flow:

- The bypass lines should have adequate capacity and size to handle all flows with emergency backup plans to ensure there is no interruption in flow. The bypass pipes and fittings should have enough strength to withstand the surge pressure.
- It is the responsibility of the contractor to perform the work in such a way that ensures there is no spills or overflows at any time.
- If there is an overflow or spills due to the work performed, the contractor should take appropriate actions, such as stop the overflow, clean the spillage and disinfect the affected area. The contractor should notify the owner as soon as possible for further inspection.

11) Traffic Control Plans:

- The contractor is held responsible for the traffic control plans.
- Traffic control manuals of municipalities and road owners should be followed.
- Occupational Safety and Health Administration (OSHA) standards should be followed.
- Manual on Uniform Traffic Control Devices (MUTCD) published by U.S Department of Transportation's Federal Highway Administration should be followed.
- The timing of the work to be carried out depends upon the type of job unless specified in the contract document.
- Whenever a lane closure is required, permission should be obtained from appropriate authorities.
- The disturbed traffic should be restored to original condition as soon as the work is completed.

12) Service Reconnection:

- HDPE expands due to stress, so the newly installed pipe should be left free for the relaxation period specified by the pipe manufacturer before reconnecting the service lines.
- The saddles made up of materials compatible to the pipe should be connected in order to provide a leak free joint.
- Lateral connections should be made by Electro Fusion Saddles or Inserta-Tee connection based on the approval from the owner or as specified in the contract document.

13) Site Restoration:

- The contractor should restore all disturbed surface areas, due to construction, to their original condition or as specified in the contract documents.
- The contractor should restore all the launching pits to the original condition as it was before excavation or as specified in the description of work.
- Prior to backfilling lateral and launching pits, the contractor shall ensure that the new pipe is properly supported and on the required grade. Appropriate material according to the contract document shall be used to support the new pipe to avoid sagging after backfill and compaction.