

# INTELLIGENT ADVISORY SYSTEM FOR SUPPORTING COMPUTER-BASED AUTHENTICATION USERS

**Mapayi, T**

School of Computer Science  
University of KwaZulu-Natal  
Durban, South Africa  
tmapayi@yahoo.com

**Olaniyan O. M. , Isamotu N. O. & Abosede-Brown I.**

Department of Computer Science  
Bells University of Technology  
Ota, Nigeria  
tayoolaniyan2001@yahoo.com, nehehandsome@yahoo.com, iyinolabrown@gmail.com

---

## ABSTRACT

Authentication is one of the cornerstones of computer security systems today, and most users of computers interact with these mechanisms on a daily basis. However, human factor has often been described as one of the weakest part of computer security as users of authentication are often identified to be the weakest link in the security chain. In related development it has been demanding to merge usability with security in the choice of authentication method by computer users. To address the serious problem, this paper presents an intelligent advisory system based on artificial neural network that can assist users of authentication systems on making decision on the authentication method that best suits them.

**Keywords:** Intelligent, Advisory system, Authentication, Human Factors

---

## 1. INTRODUCTION

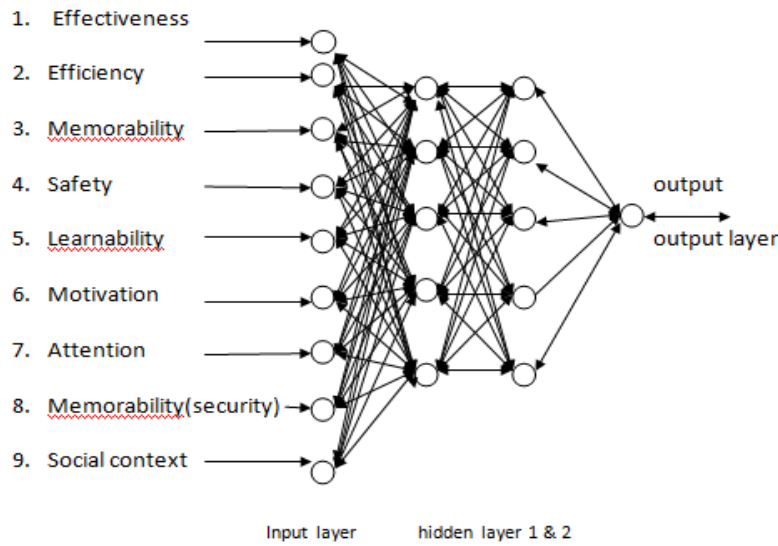
Decision making, often viewed as a form of reasoning towards action is of great interest in many disciplines. Decision problem aims to select the "best" or sufficiently "good" choice(s) that are feasible among different alternatives [1]. Intelligent advisory systems support decision makers in different domains. Over the years it has proved extremely demanding to merge usability with computer security in the choice of authentication methods. This somewhat mutual exclusivity of the two terms has placed users of computer authentication methods in perilous positions. Although, the extreme demand to merge usability with security in the choice of authentication methods has been described as one of the human factor related weakest points, the need for intelligent advisory systems that can assist users to choose the best suited authentication method while considering both usability and authentication security is highly desirable.

## 2. RELATED WORKS

Neural networks have emerged as an important tool for classification purposes [2]. The recent research activities in neural classification have established that neural networks are a promising alternative to various conventional classification methods. Neural network applications can be grouped into clustering, classification/pattern recognition, function approximation and prediction system [3].

The term user-centered security was defined as "security models, mechanisms, systems, and software that have usability as a primary motivation or goal. Therefore, focusing on the users in the development of secure systems is of great importance [8]. Rather than blaming users for being a part of weak points in the security chain, there is a need to understand the roles and demands placed on them by security systems, and proffer solutions [6]. Kaind et al. [4] explained that security is aimed at making undesirable actions more difficult while usability aims at making desirable ones easier for the user, thus improving one also improves the other. Creating a usable system will minimize unintentional errors, while a secure system will aim at ensuring that undesirable actions in a system are prevented or mitigated.

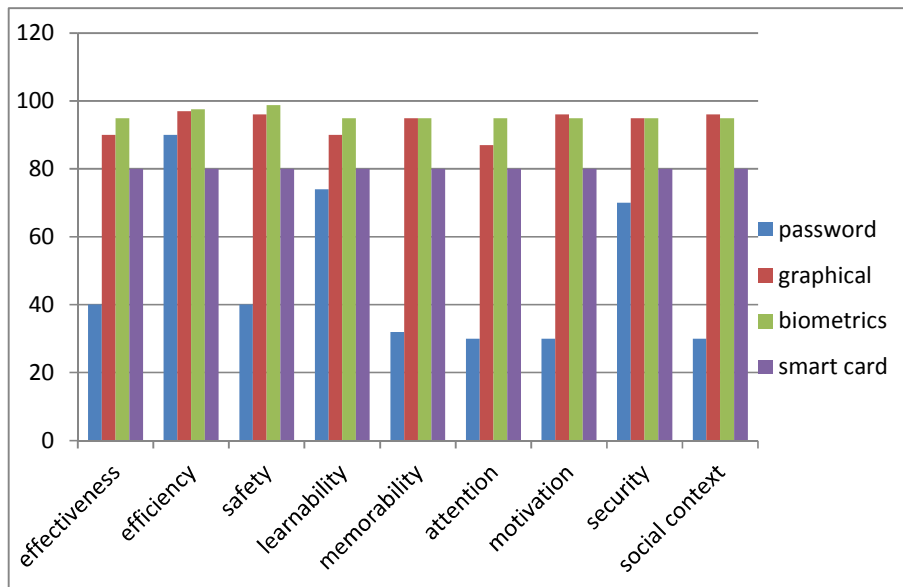
Sasse et al. [7] summarized the research on the usability of security mechanisms and discussed options for increasing usability and the effectiveness of the security mechanisms. It was iterated that usable security is not simply an issue of 'fixing' user interfaces to current mechanisms; rather, a change in how individuals, organizations and governments think about security is required. Effective security has to take into account the needs of all stakeholders, acknowledge that their needs sometimes conflict and find a solution that is acceptable for all stakeholders in ongoing use. Several factors that can influence usability of authentication systems were identified by [5]. These factors identified in [5] include effectiveness, efficiency, memorability, safety, learnability, motivation and attention.



**Fig 1: Neural Network Architecture for Usability-Centered Authentication Evaluation (Adapted from Mapayi et al. [5])**

**3. MATERIALS AND METHODS**

There are presently no standard usability scales for authentication methods. The usability factors identified in [5] as shown above were incorporated into our questionnaire. These questionnaires were distributed to 300 computer users, but 100 responses were received. The population selected was designed to obtain adequate and diverse views as related to the level and measurement of usability factors of the different authentication methods. The authentication methods involved in this research are text password, graphical password, biometrics, and smart cards. Each of the usability factors uses the scales of 1 to 5 varying from strongly agree to strongly disagree. The chart below shows a summary of the results collected from our questionnaires.



**Fig 2: Summary of Users' Authentication Preference Based on Usability Factors**

As shown on the chart above, more users prefer biometric authentication and graphical authentication due to their high usability and security, while a lower percentage of users prefer smart card and password authentication. The basic network used for training and testing is the feed-forward back propagation neural network. This was achieved using neural network in Matlab software. The feed forward network for usability information was created using a network object. It should however be noted that most times simulation calculations might vary for a concurrent set of input vectors. This is because every set of simulation involves generation of a random seed which must vary for every simulation sequence performed.

The training phase of the neural network was experimented using the data gathered from the questionnaire based on the usability information of authentication methods as the network weights and biases are then initialized. The network in our case is trained for regression. The process of training usability information requires a set of examples of proper network behavior in which the default performance function for feed-forward networks is mean square error. The network applies performance function to determine how to adjust the weights to optimize performance. The gradient is determined using a technique called back-propagation.

The back-propagation computation is derived using the chain rule of calculus and a learning rate is used to determine the length of the weight update (step size). In most of the conjugate gradient algorithms, the step size is adjusted at each iteration.

As stated earlier, logistic regression is the basic model for this study because the responses are in categorical form. Logistic regression analyzes binomially distributed data of the form.

$$Y_i \sim B(n_i, p_i), \quad \text{for } i=1, \dots, n \quad \dots\dots\dots \text{Eq. (1)}$$

where the numbers of trials  $n_i$  are known and the probabilities of success  $p_i$  are unknown. The model proposes that for each trial there is a set of explanatory variables which can be thought of as being in vector  $X_i$  and the model therefore takes the form:

$$p_i = E\left(\frac{Y_i}{n_i} / X_i\right) \quad \dots\dots\dots \text{Eq. (2)}$$

The logits of the unknown binomial probabilities are modeled as a linear function of the  $X_i$ ,

$$z = \log\left(\frac{p_i}{1-p_i}\right) = \beta_0 + \beta_1 x_1 + \beta_2 x_2 + \beta_3 x_3 + \dots + \beta_k x_k \quad \dots\dots\dots \text{Eq. (3)}$$

In logistic regression model, the relationship between ‘input’,  $z$ , and the probability of the event of interest is described by the function.

$$f(z) = \frac{1}{1 + e^{-z}} \quad \dots\dots\dots \text{Eq. (4)}$$

The variable  $z$  is known as the logit and is usually defined as

$$z = \beta_0 + \beta_1 x_1 + \beta_2 x_2 + \beta_3 x_3 + \dots + \beta_k x_k \quad \dots\dots\dots \text{Eq. (5)}$$

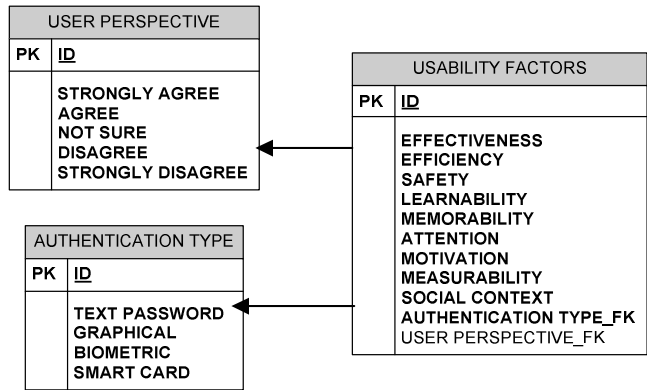
Therefore, it follows that

$$f(z) = \frac{1}{1 + e^{-(\beta_0 + \beta_1 x_1 + \beta_2 x_2 + \beta_3 x_3 + \dots + \beta_k x_k)}}$$

$$\dots\dots\dots \text{Eq. (6)}$$

The model also assumes that  $z$  is linearly related to the predictors.

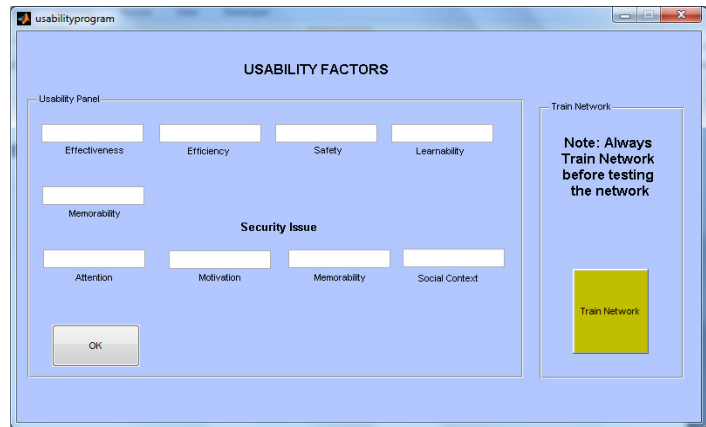
The Neural Network based system feeds in the data from the database for the network training. The figure below describes the database schema.



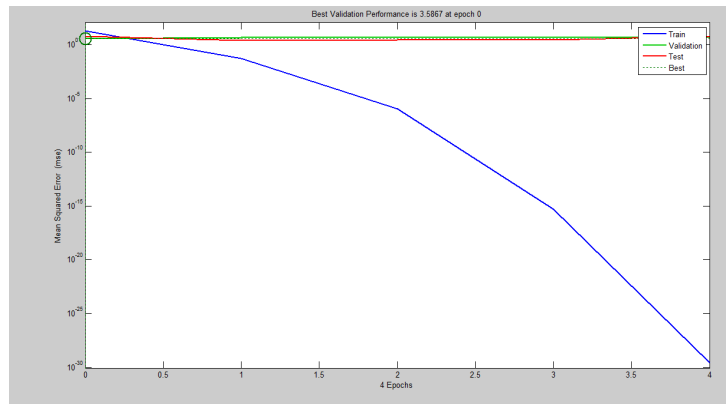
**Fig 3: Database Schema for the Authentication Methods Usability**

**4. IMPLEMENTATION**

The user interface at the right pane includes a button for training the network using the dataset from the database. Appropriate inputs on a scale of one to five which describes the level of agreement as related to usability factors as regarding each form of authentication method from the user’s view are accepted and the output of the advisory system indicates the "best" or sufficiently "good" choice among the alternative authentication methods available. It must be noted that the means square error of the performance must be greater than zero for optimal prediction

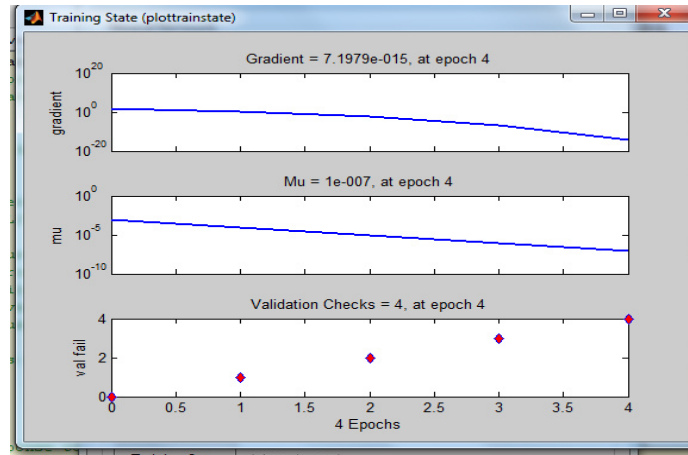


**Fig 4: Usability factor graphical user interface using Matlab**



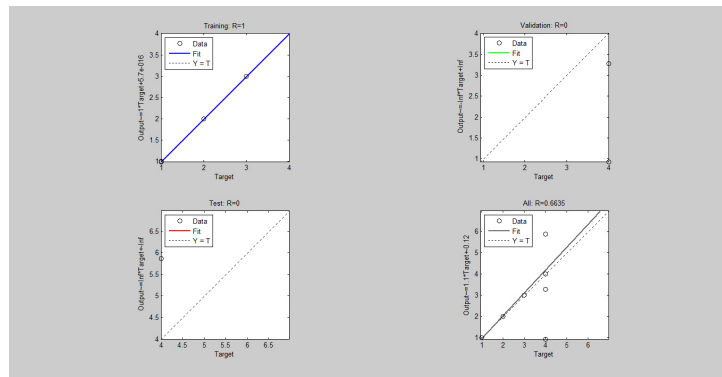
**Fig 5: Performance of the neural network for 4 epochs**

The iterative process of reducing the error and achieving optimal values for the training set is called the epoch. The graph displays the overall performance of the neural network.



**Fig 6: Training State**

The figure above shows how errors are reduced in the artificial neural network as it is continuously trained over time.



**Fig 7: Regression of sample space of Training Set, Validation Set, Test Set and Total Regression.**

The top left graph explains regression between the training set. The top right graph explains that during the validation phase the regression value is zero. The bottom left graph explains that during the test phase the regression value is zero. The bottom right graph explains the total regression for the test training and validation phase according to the graph the regression value is 0.6625. This implies that there is a relationship between the components of usability as presented to the neural network.

It will also further explore possible additional factors that will help achieve a more robust intelligent advisory system as it investigates how it handles both domain and user specificity.

**5. CONCLUSION AND FUTURE WORKS**

This paper has been able to present an intelligent advisory system based on artificial neural network. The system integrates usability with security in the choice of authentication method, thereby helping computer users to select the "best" or sufficiently "good" choice of authentication method that best suits each user. Future work will be concentrated on adopting the system to support users on the choices of a sufficiently good multifactor authentication method that best suits them.

## REFERENCES

1. Amgoud L. and Prade H., 2009. "Using arguments for making and explaining decisions" *Artificial Intelligence*, vol. 173, pp. 413-436. [www.sciencedirect.com/science/article/pii/S000437020800194X](http://www.sciencedirect.com/science/article/pii/S000437020800194X)
2. Anderson D. and McNeill G., 1992. "ARTIFICIAL NEURAL NETWORKS TECHNOLOGY A DACS State-of-the-Art Report", August 20. Prepared for: Rome Laboratory. RL/C3C. Griffiss AFB, NY (4)
3. Chakraborty R.C., 2010. "Fundamentals of Neural Networks", AI course lecture 37-38, notes, slides. [www.myreaders.info/08\\_Neural\\_Networks.pdf](http://www.myreaders.info/08_Neural_Networks.pdf)
4. Kaind R., Flechais I. and Roscoe A.W., 2010. "Security and Usability: Analysis and Evaluation". International Conference on Availability, Reliability and Security, IEEE 2010.
5. Mapayi, T., Olaniyan, O. M., Isamotu N. O., Raji S. O., Olaifa Moses S. 2013. "Evaluating Usability Factors In Different Authentication Methods Using Artificial Neural Network ", *Africa Journal of Computing & ICT* (IEEE Nigeria Chapter Publication), Vol 6. No. 1.
6. Patrick A., 2002. "Human Factors of Security Systems: A Brief Review". [www.andrewpatrick.ca/passwords/passwords.pdf](http://www.andrewpatrick.ca/passwords/passwords.pdf)
7. Sasse, M.A., 2004: "Usability and trust in information systems". In: "Trust and Crime in Information Societies", edited by Robin Mansell and Brian S Collins, pp. 319-348. Edward Elgar. ISBN 1 84542 177 9.
8. Zurko M. E., 2011: "User-Centered Security: stepping Up to the Grand Challenge". [www.acsac.org/2005/papers/Zurko.pdf](http://www.acsac.org/2005/papers/Zurko.pdf)

---

## Authors Profile



**Mapayi T.** is a doctoral research student at the School of Computer Science, University of KwaZulu-Natal, Durban, South Africa. He had his BSc in Computer Science at the University of Ado-Ekiti, and his Msc at the University of Ibadan, Nigeria. He is a member of Computer Professionals of Nigeria. His areas of research includes; Biometrics, Computer Security, Computer Vision and Pattern Recognition and ICT for Development,. He can be reached through Email: [tmapayi@yahoo.com](mailto:tmapayi@yahoo.com).



**Engr. Olaniyan Olatayo Moses** (M.SC), a Lecturer at Bells University of Technology, Ota, Nigeria. He teaches computing in the Dept of Computer Science and Information Technology. Engr Olaniyan obtained the B.Tech Computer Engineering degree from the Ladoke Akintola University of Technology, Ogbomoso and a MSc in Computer Science from the University of Ibadan, Ibadan, Nigeria. Presently on PhD degree focusing on Telemedicine Research his other research interest includes Computer Networks and Human Computer Interaction. He can be reached through E-mail: [tayoolanivan2001@yahoo.com](mailto:tayoolanivan2001@yahoo.com)



**Isamotu Nehemiah O.** is a graduate of Bells University of Technology, Ota, Nigeria. He can be reached through E-mail: [nehehandsome@yahoo.com](mailto:nehehandsome@yahoo.com)

**Abosede-Brown Iyinola** is a graduate of Bells University of Technology, Ota, Nigeria. She can be reached through E-mail: [iyinolabrown@gmail.com](mailto:iyinolabrown@gmail.com)

---

# THE IMPACT OF BUSINESS ENVIRONMENT ON ENTREPRENEURSHIP PERFORMANCE IN NIGERIA

**Adeoye Muyiwa O.**  
Department of Accounting  
Adeleke University  
Ede, State of Osun, Nigeria.  
muyiwadeoye@gmail.com

---

## ABSTRACT

The business environment has been a vital point to consider in evaluating entrepreneurial performance, researches have established that there is relationship between entrepreneurial activity and the environment in which it is domiciled. This paper x-rayed the impact or especially the influence of the Nigerian business environment as it affected the productivity of the entrepreneur operating in the country. The paper is structured into various parts. The first is the introduction followed by part two which looked at the definition of the keywords, explained the nature of the business environment and its component parts, also discussed the importance of the business environment to an entrepreneur. Conceptual issues relating to this paper was deliberated upon. The study depended on resources from academic publications, reports and publications of government agencies and other stakeholders in the field of entrepreneurship in Nigeria and outside the country. The paper therefore argues in conclusion that the government is the vital organ that can lead to a beneficial business environment. It also recommends the inclusion of entrepreneurship in the curriculum of schools, ensuring that the NYSC period is loaded with workshops and seminar on entrepreneurship.

**Keywords:** Business Environment, Entrepreneurship, Nigerian Business Environment.

---

## 1. INTRODUCTION

The relationship between entrepreneurship and the entrepreneurial environment has been given attention in the last few decades. The Nigerian business has been evaluated and assessed by several scholars and several suggestions have been recommended but there has been no visible change, particularly in the area of unemployment in the country. A recent survey conducted by the National Bureau of Statistics in 2011 showed that overall unemployment rate increased from 21.4 per cent in 2010 to 23.9 per cent in 2011. Further analysis showed that the unemployment rate in rural and urban areas was 25.6 and 17.1 per cent respectively. People who are less than 14 years constituted 39.6 per cent while those between 15 and 64 years constituted 56.3 per cent. (National Bureau, 2012).

A business environment comprises of such factors as infrastructure, cultural, economic, social and political environments. These environmental forces have been found to be capable of either impeding or facilitating entrepreneurial activities in any economy. The World Bank is of the opinion that improvements in the enabling environment leads to greater levels of investment by the private sector, more wealth, job creation, and ultimately more poverty alleviation. The best way for government to understand how to improve the enabling environment is to involve the private sector through consultation and dialogue and, in particular, to understand and address the private sector's needs and priorities as they are actively involved in nation's building.

Entrepreneurial development has continued to be a popular concept in the world due to its leading role as catalyst for nation's growth and economic development. Entrepreneurship globally, can boast of being a major employer of labour if compared to major industries and multinationals (Kadiri, 2011).

The Nigerian government has initiated several programmes that are geared towards the mobilization, training and supporting initiatives that will promote financial literacy and entrepreneurship development. Despite all these, the efforts seems abortive, this can be linked to the problems embedded in the Nigerian business environment, some of which are corruption, unavailability of good roads, erratic power supply, political instability, presence of inflation, inadequacy of Information which is analyzed adequately in the subsequent section of this paper.

The relationship between business and its environment is one of mutuality: that is, the environment exerts pressure on the business while the business, in turn, influences some aspects of its environment. (ICAN, 2009).

### 1.1 Research Significance

There is a close and continuous interaction between the entrepreneurship business and its environment. This interaction helps in strengthening businesses and using its resources effectively. The business environment is multifaceted, complex, and dynamic in nature and has a far-reaching impact on the performance and growth of the entrepreneurship business. The proper understanding of the social, political, legal and economic environment will help the entrepreneur to determine opportunities and threats to its business. The environmental analysis of entrepreneurs makes the tasks of entrepreneurs easier in dealing with business challenges, image building and meeting with competition to achieve performance and growth. The interaction between the business and its environment is therefore imperative to give direction for growth and expansion of the entrepreneurs business showing their sensitivity to the environment within which they are domiciled.

## 1.2 Research Questions

In carrying out this research some questions become imperative:

- a) What are the different environments in which an entrepreneur operates?
- b) What factors influence the economic performances of entrepreneurs?
- c) What are the challenges in business environment of entrepreneurs?
- d) What are the impacts of all these environmental factors on the performance and growth of entrepreneurship in Nigeria?

## 1.3 Study Objectives

The main objective of this research is to investigate the impact of Business environment on entrepreneurship performance in Nigeria. In achieving the main objective there are specific objectives and they are to;

1. Investigate the relationship between business environment and Entrepreneurship activities.
2. To unveil the environmental challenges confronting businesses in Nigeria.
3. Identify the impact of the Nigerian business environment on entrepreneurs productivity.
4. To review the different environments of business.
5. To assess Governments monitoring and control activities to ensure entrepreneurship performance in sustaining economic development in Nigeria.

## 2. RELATED LITERATURE AND CONCEPTUAL ISSUES

The Nigerian business environment had existed since the colonial era and it was predominantly by the colonial masters. It was after Nigeria got her independence that the Nationals started clamoring for indigenization. This led to the period where the Nationals got involved in the business sector and this gave birth to entrepreneurship. The Nigerian business environment has not been conducive for entrepreneur to tap into judging by the current level of unemployment which should be nerve-racking for Nigeria's leaders. In order to appreciate this paper it will be appropriate to give an insight to the keywords of this paper.

A business does not operate in a vacuum. Normally, a business operates in a multidimensional environment. The environment itself is subject to a large degree of change. The affiliation between business and its environment is one of mutuality: that is, the environment exerts hassle on the business while the business, in turn, influences some aspects of its environment. The nature of the environment in which the business enterprise operates therefore needs to be clearly understood by managers. (ICAN, 2009)

The concept of business environment according to the business dictionary (2013) can be defined as the combination of internal and external factors that influence a company's operating situation. The business environment can include factors such as: clients and suppliers; its competition and owners; improvements in technology; laws and government activities; markets, social and economic trends.

Ask.com (2013) defines business environment as the physical and operational factors, both internal and external, that affect the flow of activities in a business. They include; customers, competitors, suppliers, distributors, industry trends, substitutes, regulations, government activities, the economy, demographics, social and cultural factors, innovations and technological developments. A business is influenced by the environment in which it operates and the success of any business is dependent on its ability to adapt to its environment. The complexity of this reality for business owners is compounded by the fact that there are many different environments that each business operates in. There is the macro environment, which in today's global economy refers to the whole world, where events often indirectly impact on businesses and there is the microenvironment, local events and circumstances which directly affect and interact with a business. (GIBS, 2013). A business' environment influences the functioning of the business system. Therefore, a business environment may be defined as all those conditions and forces which are external to the business and are beyond the individual business unit, but they all operate within it. These forces are customers, creditors, competitors, government, socio-cultural organizations, political parties' national and international organizations etc. Some of these forces affect the business directly whilst some others have an indirect effect on the business (Blurtit,2013)

According to the Institute of Chartered Accountants study pack (2009) business environment can be defined as a set of factors or conditions that are external to the business but which have influence on the operations of the business enterprise. External in the context means that these factors or forces are not usually within the control of the business enterprise. It further describes it as the web of forces which form the setting in which the firm makes its decisions.

In order to succeed, an entrepreneur must take its environment into account in making its decisions. The conditions or factors within the business represent its internal environment. Contrasting the elements of the external environment, these conditions or factors are generally viewed as controllable by the business. Examples are the quality of interpersonal and inter-grouped relationships, the nature of the production and distribution facilities, financial and human resources, etc are subject to the control of the firm. The external environment is generally interpreted as uncontrollable as no single business can ascertain or influence it. Erstwhile the external environment is the surrounding in which all firms in the industry operate.

Entrepreneurship is the act of being an entrepreneur. Entrepreneur is from a French word 'entreprendre' which means somebody who initiates or finances new commercial enterprises (Encarta). Shapero (1981) describes entrepreneurship as key to self renewing economies. According to Drucker (1985) Entrepreneurship is the willingness and the ability of an individual to seek out an investment opportunity, establish an enterprise based on this and run it successfully either for profit making or social benefit. Jegede (1990) define entrepreneurship as a force that mobilizes other resources to the unmet market demand.



Griffin and Hammis (2001) terms entrepreneurship as starting a new business based on a recognized business opportunity as well as operating and maintaining that business. The two further opinionated that some people believe that entrepreneurship does not need to be taught and therefore, an entrepreneur is born to be so. It should however be noted that for one to be a successful entrepreneur, he/she needs to learn the skills.

### **2.1 The Link Between Entrepreneurship and Its Environment.**

The actual indication of the functions and roles of entrepreneurship in socio-economic development have often been attributed to the presence of certain factors in the external environment of the entrepreneur over which he has little or no jurisdiction. Borkowski and Kulzick in 2006 list the interaction between entrepreneurship and environment as follow:

- a. new venture strategies are formed in response to environmental forces
- b. entrepreneurs are negative towards and will resist political interference
- c. unstable environments are negatively related to growth opportunities.

There has been an assortment of viewpoint put up to scrutinize the links between entrepreneurial activities and the environment. Outstanding among these is the work of Thornton (1999) who attributed entrepreneurial activities in a society to the following explanations; Supply-side and Demand-side perspectives. The supply-side perspective emphasizes the role of individuals in creating entrepreneurial environment. According to Thornton (1999) the supply-side, holds that "special types of individuals create entrepreneurship". This is further linked to economic development or undevelopment. This perspective attributes economic development of any society to an adequate supply of 'special' individuals with traits that are well-matched with entrepreneurial practices. Thornton (1999) defines the demand side perspective, which actually came from the works of Marxists, economists and geographers, as an "opportunity structure, an 'objective' structure of economic opportunity and a structure of differential advantage in the capacity of the system's participants to perceive and act upon such opportunities".

An entrepreneur is also expected to classify business prospects as well as taking the risk of utilizing the business opportunities. A business depends on its environment for the supply of all its input and at the same time absorbs the output of the business enterprise. The environment provides opportunities for alternative investment which the business manager can exploit to his or her advantage. On the other hand, the environment could start a threat or constraint. For a business to survive in the long run it must be seen as coping, adapting, and responding favorably to the environment it operates in. (ICAN, 2009). Changes in the external environment of a business may induce a change in the strategy, structure, technology or the nature of human resources that the firm employs, into the business enterprise if changes in it are unfavorable.

### **2.2 External Environment**

The features of external environment are:

#### **1. Economic Environment:**

We must take knowledge of the point that these factors could and do operate most of the time concurrently. Consistently, managers in the organization should be worried about the trends in the economic conditions in their decision making. This is defined by factors such as:

- (a) Gross Domestic Product (GDP)
- (b) Government Fiscal and Monetary policies
- (c) Unemployment rate
- (d) Exchange rate
- (e) Inflation rate, and
- (f) Capacity utilization

#### **2. Socio-cultural Environment:**

This is a composite series of social and cultural conditions established in the society which have far reaching effects on business conditions. The social and cultural conditions in which the organization operates can be understood by studying the demographic characteristics of the population, nature and lifestyle of the people, the groups they form and the nature of interactions among the groups and the institutions they have created for themselves.

#### **3. Political Environment:**

The government of every country should be considered with the interest of the nationals in any political arrangement. It should ensure that there are structures put in place for the maintenance of law and order, provision of basic infrastructure and security of life and property to create an atmosphere where meaningful business activities thrive. Also, the government should ensure that while developing or making policies, laws and regulations, it should help to accelerate and improve the welfare of the society. In view of the foregoing, business organizations that are armed with the policy thrust of the government are able to anticipate the pulse and direction for the government and thereby adjust their operations accordingly. However, in times of political instability, there is a situation of policy instability and uncertainty from the point of view of business organizations. In addition, in most developing nations like Nigeria, Ghana, etc., a change in government does not always follow clear-cut procedures. These frequent changes in governments especially during military dictatorships create unnecessary tensions and uncertainties.

#### **4. Technological Environment:**

The technological environment can be regarded as the state of the use of scientific principles and mechanical arts to different tasks in the society. In the Nigerian context, the local technology is applied by those who engage in peasant farming, small scale businesses and even in the mining, quarrying and construction business. On the other hand, more advanced technology is engaged in the steel industry, the breweries, textile, banks, hospitals, etc. Nigeria, Ghana, Liberia etc are not self sufficient in their technological input as they rely heavily on modern technologies from America, Japan, India, Korea, Europe, etc. However, their dependence on foreign technologies has to some extent, advanced the technological climate positively.

### 5. Legal/public Policy Environment:

This consist of the laws, regulations and procedures of a country which business enterprises are anticipated to comply with in the course of their operations. These laws may facilitate successful business conduct as well as constitute major handicaps to successful performance. Furthermore, in carrying out their business operations, business enterprises are required by law to pay taxes, value added tax, capital gains tax, education tax, import duties, excise duties, etc. There are also labour laws that synchronize the contract of employment specifically the relationship between employers and the unions, the minimum age a person must attain before he/she can be lawfully employed, employee compensation, etc.

### 6. International Environment:

This refers to all those elements on the international scene, which can help or inhibit the decisions and operations of the business enterprise. Changes in the economic, social, technological, political and public policy issues affect the operations of businesses. This is because most companies depend on imported raw materials, technology and other services or export their goods and services overseas.

### 2.3 Conceptual Issues

In 2007 Ogundele viewed entrepreneurship as a multidimensional phenomenon. It was found that the processes of emergence, behaviour and performance of indigenous entrepreneurs were separately and in combinations affected not by a single but multiple factors, in ranging degrees. These factors included economic, socio-cultural, ecological, managerial, educational developmental, experiential, technological, structural, ethical and innovative issues. He concluded that any policy designed to change entrepreneurship scenario in Nigeria will require multiple and simultaneous approaches in the development of necessary changes in the behaviour of indigenous entrepreneurs.

The CBN-supported EDC's aim at developing the entrepreneurship spirit in Nigerians and providing insight into the tools, techniques and framework for managing business enterprise, including production, marketing, personnel and finance. They also develop skills of would-be-entrepreneurs to successfully start, expand, diversify and manage business enterprises, as well as link them with financial institutions for accessing start-up capital, especially from the microfinance banks; and to generate employment opportunities for Nigerians in pursuance of

the provision of the National Economic Empowerment and Development Strategy (NEEDS) and more recently, Vision 20:2020. (Sanusi, 2012)

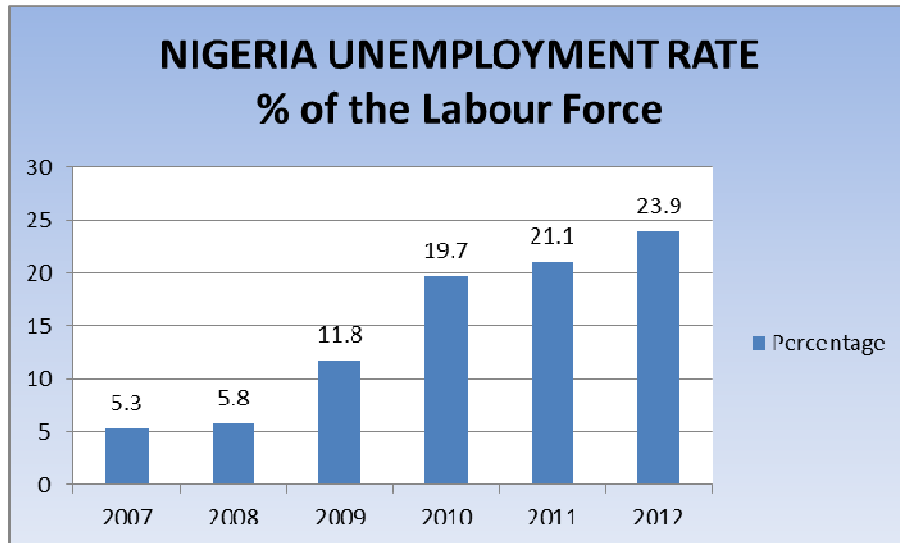
The World Bank (2005), as part of its findings in a study on Doing Business across the globe asserts that:

- Businesses in poor countries face much larger regulatory burdens than those in rich countries. They face three times the administrative costs, and nearly twice as many bureaucratic procedures and delays associated with them. And they have fewer than half the protections of property rights of rich countries.
- Heavy regulation and weak property rights exclude the poor from doing business. In poor countries 40% of the economy is informal. Women, young and low-skilled workers are hurt.

The World Bank's *Doing Business 2008* report quotes Nigeria as ranking 108 among 178 economies compared. The report finds many Sub-Saharan countries like Mauritius, Botswana, Ethiopia, Ghana, Kenya, and South Africa are more business friendly than Nigeria.

Chinonye (2010) submitted that some financial institutions are not willing to give financial assistance to small-scale entrepreneur because of high mortality rate of the business and inability to produce viable business plans and guarantors for the business. According to Akeredolu-Ale (1975) His conclusion was that the problems that were confronting the indigenous entrepreneurs in Nigeria could only be partly explained by the economic factors.

According to tradingeconomics.com a statistic of the unemployment rate in Nigeria increased to 23.90 percent in 2012 from 21.10 percent in 2011. Unemployment rate in Nigeria is reported by the National Bureau of Statistics. From 2007 until 2012, Nigeria unemployment Rate averaged 14.6 Percent reaching an all time high of 23.9 Percent in December of 2012 and a record low of 5.3 Percent in December of 2007. In Nigeria, the unemployment rate measures the number of people actively looking for a job as a percentage of the labour force. This is depicted in the chart below.



**Fig. 1: Unemployment Rate as a Percentage of the Labour Force.**  
Source: National Bureau of Statistics | www.tradingeconomics.com

Several Selected policy programmes aimed at entrepreneurship development in Nigeria had been introduced to enhance the business environment and make it viable for entrepreneurs to be profitable (Sanusi 2003). Examples are enumerated below:

1. Industrial Development Centres (IDCs): The objective is to provide extension services to SMEs in project. The problems that affected this are the lack of adequate appraisal and training equipment and sufficient funding.
2. Small Scale Industries Credit Scheme (SSICS): This was set up to provide technical and financial support for the SMEs. This policy was truncated by inadequate manpower to monitor advances leading to repayment default.
3. The Nigerian Industrial Development Bank (NIDB): This was designed to provide medium to long term loans for financing of industrial activities. The observation on this policy was that of financial and administrative constraints during the merger controversy.
4. The Nigerian Bank for Commerce and Industry: The bank was set up to provide financial services to indigenous business community and to administer the SME | World Bank Loan Scheme. The bank suffered operational problems, which resulted into a state of insolvency
5. National Directorates of Employment (NDE): This was responsible for vocational skills development and small scale enterprises programmes designed to combat unemployment.. This has not been effective due to lack of commitment by the different tiers of government to its operations.
6. National Economic Reconstruction Fund (NERFUND): This was created to fill the gap in any observed inadequacies in the provision of medium to long term financing to small and medium scale industrial enterprises. This fund was affected during the merger storm.
7. Family Economic Advancement Programme (FEAP): This was established to provide micro facilities for entrepreneurs. This was discontinued due to change in government.
8. People's Bank: Designed to make banking services more accessible and extend credit to the poor. Discontinued due to change in government
9. Community Bank: Designed to make banking credit accessible to the active poor. Discontinued and substituted with Microfinance Banks.
10. Better Life Programmes/Family Support Programme (BLP/FSP): Aimed at sensitizing and providing micro-credit facilities for women entrepreneurs. Discontinued due to change in government
11. Small and Medium Enterprises Development Agency of Nigeria (SMEDAN): This was established to promote the development of the MSME (Micro, small and medium scale enterprises) sector of the Nigerian Economy. The impact is not felt at all levels of societal strata.
12. Small & Medium Enterprises Equity Investment Scheme (SMEEIS): To provide credit facilities for small and medium entrepreneurs. Lack of national spread in implementation
13. Micro Finance Banks Established to provide finance for the active poor in the population. The problem of these banks is the lack of national spread and high interest rate.

The Nigerian business environment has some peculiar problems which is currently making it difficult for entrepreneurial activities to thrive well. The major factor that makes business difficult in Nigeria is power. In 2010 Jide Mike in an economic and financial review enumerated some of the problems:

- a) Near collapse of critical social and economic infrastructure.
- b) High bank lending rates which are a great disincentive to new investment.
- c) Mortal killing small and medium enterprises.
- d) Lack of long-term investible funds for manufacturing activities.
- e) Government policy inconsistency.
- f) Deepening weak aggregate consumer demand.
- g) Massive influx and dumping of all kinds of imported finished goods.
- h) Multiplicity of taxes and levies.
- i) Low government patronage of locally manufactured goods.
- j) Insecurity of life and property, etc.

Some others are the presence of inflation, corruption, lack of adequate information and political instability. The Guardian newspaper in August 2013 reported that in the last three decades, different administrations, often in collaboration with the private sector, have embarked on youth employment programmes, leading to the establishment of the National Directorate of Employment (NDE), the Small and Medium Enterprises schemes, the poverty alleviation programme, the Subsidy Reinvestment and Empowerment Programme (SURE-P) and the Youth Enterprise With Innovation in Nigeria (YOUWIN). However, these employment and empowerment programmes have been largely souvenirs because they were tied to political partisanship and emanated from ad hoc reactionary circumstances, rather than deliberate national planning agendas. There are indeed reasons to question the genuineness of these schemes in conception and coverage. The poor (if not clandestine) publicity given to these schemes, the scope of mandate and the modus operandi for participating in them, among others, give rise to suspicion that the proposals were never intended to alleviate the unemployment situation.

### 3. METHODOLOGY

The methodology employed for this study is descriptive analysis with qualitative reporting. Descriptive research is used to describe characteristics of a phenomenon being studied. It does not answer questions about how/when/why the characteristics occurred. Rather it addresses the "what" question (Shields, Rangarajan, 2013). The study depended largely on secondary data as well as data from personal observation which could for convenience be taken as quasi-primary data. Useful secondary data were sourced from textbooks, journal publication, newspapers articles, and academic papers.

### 4. RECCOMENDATIONS

The problems highlighted above represent a significant deviation from the characteristics and requirements of a conducive business environment that the real sector needs to perform its role as the engine of growth and development. The Nigerian government should help eliminate the issues currently experienced by the entrepreneurs through consistency in Policy and programmes introduced to assist particularly the real sector. Incoming government should adopt such policies that was put in place by previous administration if such is effective and not discontinued due to change in government.

There should be adequate manpower in organization set up for the purpose of assisting the entrepreneurs so that the monitoring processes of advances and loans does not lead to repayment defaults, they should also ensure commitment by the different tiers of government to its operation. Government should ensure proper funding of all programmes so as to prevent the truncation at a premature stage.

The impact of the policies should be felt at all levels of societal strata. Also, the problem of inadequacy in the number of banks established should be eradicated by providing enough branches of the banks and the agents as the case may be, ensuring the whole populace enjoys such benefits. The Nigerian government through the Central bank of Nigeria reduces the high interest rate of the loan, so that more entrepreneurs can enjoy such facility. Furthermore there should be adequate and regular appraisal of each programme.

The government should closely monitor the level of inflation as this is an economic condition characterized by a general and continuous rise in the price level coupled with a fall in the value of money. This will result in economically harmful effect to entrepreneurs because of instable quoted market prices. The National Independent Power Project(NIPP) which currently took off should be closely monitor, so that it can bring to end the erratic power supply to the entrepreneurial activities which makes them experience high cost of production. The government should support the private sector in ensuring the effectiveness and efficiency of the NIPP.

The government should greatly improve on the provision of infrastructural amenities. Roads to be repaired so as to enhance accessibility for the entrepreneurs this in the long run will reduce cost of production and there will be a high yield in the level of turnover realized by the enterprises. The problem of corruption is a national one and as such more stringent policies should be put in place, adequate punishment should be given to defaulters and no immunity given, as this will serve as a deterrent to others coming behind. The Federal government agreed with the National University Commission (NUC), which directed that all universities should give their students entrepreneurship education and such that the course must be made compulsory. This should be extended to the primary and secondary schools as students mature and build on previous knowledge.

The overall purpose remains to develop expertise as an entrepreneur. It is also important to note that there is nothing like a born entrepreneur. Any entrepreneur that wants to be successful has to pass through training in order to be able to make the difference. The National Youth Service Corp (NYSC) also, should be a period whereby entrepreneurship is taught in which workshops and seminar on it can be given. In the long run this will lead to a reduction in the level of unemployment when they engage in entrepreneurial activities. The Central Bank of Nigeria (CBN), recognizing the gap in youth entrepreneurship, and also in support of the government's initiatives to grow the critical mass of youth entrepreneurs to take advantage of the opportunities in the economy, has established Entrepreneurship Development Centres (EDCs) in three geopolitical zones. The administration of these centres should be thorough and put under surveillance so that it does not collapse like the previous ones.

## 5. CONCLUDING REMARKS

Finally, the government should create a friendly or an enabling environment for entrepreneurship and consumer goods in order to boost the economy, as entrepreneurship is an employment strategy that can lead to economic self-sufficiency for the people. It makes nationals create and manage businesses in which they function as the employer or boss rather than merely being an employee. Every country aims at achieving self-sufficiency through producing what the country needs. A government does encourage industries to enhance production to satisfy internal and external demands and to achieve considerable improvement in entrepreneurship performance. Encouragement and incentives would be in form of financial assistance and state protection.

## REFERENCES

- Abimbola.O&Agboola .G (2011). Environmental Factors and Entrepreneurship Development in Nigeria Journal of Sustainable Development in Africa (Vol 13, No.4, 2011)
- Ask.com, (2013). Definition of Business Environment retrieved from <http://www.ask.com/question/what-is-a-business-environment?ad=dirN&o=0>
- ATSWA, (2009).Association of Accountancy Bodies in West Africa (ABWA) Accounting Technicians Scheme West Africa (ATSWA) Study Pack for Management Second Edition, Abwa Publishers.
- Blurtit.com,(2013).Definition of External and Internal Environment retrieved from <http://business-finance.blurtit.com/718404/what-is-the-external-and-internal-environment-of-business>
- Borkowski, N. and Kulzick, R. (2006). Perspectives from the field: Will recent public policies reduce entrepreneurship in the healthcare industry? International Journal of Public Administration, 29: 479-488.
- Business Dictionary, (2013).Definition of Business Environment retrieved from <http://www.businessdictionary.com/definition/business-environment.html>
- Chinonye, L.E.(2010). Entrepreneurship a Conceptual Approach. Lagos: Pumarck Nigeria Limited.
- Drucker, P. (1985). Innovation and entrepreneurship: Practice and principles. London: Heinemann.
- GIBS,(2013). Definition of Business Environment retrieved from <http://www.gibs.co.za/gibsdirect/modules/the-business-environment.aspx> Gordon Institute of Business Science University of Pretoria.
- Guardian Newspaper online. Retrieved from <http://www.ngrguardiannews.com/editorial/129695-unemployment-in-nigeria> Monday, 12 August 2013.
- Jegede, C.T. (1990). The development of the Small and Medium Scale Industries in Nigeria. Management in Nigeria. 26(3) 9.
- Jide A.M (2010).Banking Sector Reforms and the Manufacturing Sector: The Manufacturers' Association of Nigeria Perspective Economic and Financial Review Volume 46/4 December 2010.
- Kadiri,I.B(2011) Globalising in poverty:the small and medium scale alternative in Nigeria PPCSS International Journal Babcock University.
- Ogundele, O.J.K. [2007]. Introduction to Entrepreneurship Development, Corporate Governance and Small Business Management.Lagos: Molofin Nominees.

Sanusi,J.O, (2008) Central Bank of Nigeria, Overview of Government's Efforts in the Development of SMES and the Emergence of Small and Medium Industries Equity Investment Scheme (SMIEIS). A Paper Presented at the National Summit on SMIEIS Organised by the Bankers' Committee and Lagos Chamber of Commerce and Industry (LCCI), Lagos, 10th June.

Sanusi, L.S (2012).A paper titled Beyond Political Rhetoric: Investing In Youth As An Economic Strategy Delivered at the 2012 Oxford Pan-African Conference, University of Oxford, UK .May 5, 2012.

Shapero, A. C (1981). Self-Renewing Economies. Economic Development Commentary, 5 (April), 19-22.

Thornton, P. H. (1999). The sociology of entrepreneurship. Annual Review of Sociology, 25:19-46  
Trading.com,(2013).National Bureau of Statistics on Unemployment retrieved from <http://www.tradingeconomics.com/nigeria/unemployment-rate> economics.com

World Bank (2005). Doing Business in 2005 - Removing Obstacles to Growth. Retrieved from <http://www.doingbusiness.org/documents/DoingBusiness2005.PDF>

World Bank. (2008). Doing Business 2008 Report. Retrieved from [http://www.doingbusiness.org/documents/FullReport/2008/DB08\\_Full\\_Report.pdf](http://www.doingbusiness.org/documents/FullReport/2008/DB08_Full_Report.pdf)

# BENCHMARKING AND EVALUATING TOWARDS FULL IMPLEMENTATION OF ICT POLICIES AND STRATEGIES (ICT LESSONS FROM LESOTHO 2007-2013)

**J.M. Maphephe**

Independent ICT Adviser Electoral Projects

E-Government & Forensic Audit

Maseru, Lesotho.

.jmaphephe@msn.com or jmaphephe@gmail.com

---

## ABSTRACT

This article examines whether there is a significant shift from traditional government practise to modernised Information Communication Technology project management approach. ICT can have a wizard effect on speeding of development process of the country. ICT make it possible to deliver information by means of voice, text, data, video and graphics faster and more efficiently than before. [5]The implementation of ICT policies, strategies and developments provide an enabling environment for Government to work with the private sector and civil society to improve and expand access to information for all its citizens. There are many challenges and obstacles that Lesotho as country is facing in the implementation of ICT policies and strategies. The key among these obstacles has been identified in various ICT professional reports as the lack of a unified approach through the entire Government ministries, agencies and public sectors. Lesotho Government has been identified as the key driver of these policies and strategies by actively engaging the public in the process. Lesotho has pronounced its dream which is to be fully incorporated member of the Information Society. Why obstacles? Can Lesotho achieve the ambitious dream in 10 years to come and regained the cost-effective developing world through the use of ICT as tool for growing Lesotho economic and if so, how? This paper looks into the processes by reviewing the Lesotho ICT policies and strategies between periods of 2007 to 2013. Benchmarking process as a supporting tool for policy and strategy implementation has been applied and the results are discussed. These lessons may have relevance to many developing countries, including those on the African continent. The paper concludes with a set of recommendations on how the policies and strategies review processes should be carried out.

**Keywords,** ICT, policy, strategy, benchmarking, Lesotho, Government.

---

## 1. INTRODUCTION

As articulated [5] that integration of Lesotho into the global information society calls for development of an effective policy and regulatory framework for the implementation of such a strategy. (Twaakyondo.2011) stated that implementing of a national Information Communication Technology policy of a country is vital for the development of a nation. Lesotho like many states in the African continent recognized that (ICT) sector as a key accelerator for development, hence why the Government of Lesotho official adopted ICT policy in March 2005, and followed the policy implementation. So far tremendous progress has been made including national broadband strategy, Lesotho Government Data Network, good network connectivity from Maseru to all 10 Lesotho districts. Although it is more than 6 years the ICT sector has changed quite significantly; there is a need to review all stages of the ICT policies, strategies and finally come up with suggestions for improvements as necessary.

The arguments will illustrate the analysis carried out and the results from three relatively successful African countries, namely South Africa and Kenya and Botswana, in ICT policy and strategy implementation. Besides the policy and strategy process and stakeholder's involvement, national goals, objectives and mission are discussed. The institutional arrangements for the implementation from Maseru being the capital city to all 10 districts.

It is important to note that Government of Lesotho has developed ICT policy that cognizant of converged technologies. It captures the Dynamic and pervasive nature of the technology. To further embrace the policy, Lesotho Government adopted an ICT strategy; The ICT strategy supports, underpins and aligned to the Government business objectives and priorities as well as the overarching vision of the Lesotho National ICT Vision and Mission statements, which have been stated as: To create a knowledge-based society fully integrated in the global economy by 2020, AND "To fully integrate information and communications technologies throughout all sectors of the economy in order to realise rapid, sustainable socio-economic development."

## 2. BACKGROUND

[5]ICT strategy in the context of Lesotho is in effect a plan. It shapes the development work to be carried out in respect of ICT as a supporting business tool, and it gives context to that development work setting out the environment in which it can effectively be executed. It is crucial that the strategy is not viewed as a static document but, rather, becomes a dynamic management tool that is used to shape and evolve the delivery of information and services within Lesotho Government. In this respect, ownership of the strategy is paramount and leadership must be seen to be coming from the most senior management of Lesotho Government.

[5] Claimed that the dream of a prospering Lesotho, fully integrated in the global economy cannot be realised without a well designed ICT strategy. In order for Lesotho to seize and obtain maximum benefits from the opportunities provided by ICTs, it needs a roadmap that clearly defines what is to be done, when and how it will be done and who is going to do it. The Government having developed the Information and Communication Technology (ICT) Policy as a tool to enable Lesotho to achieve its development goals as articulated in the Lesotho Vision 2020 Policy Document and the Poverty Reduction Strategy Paper is now in a position to set up the appropriate institutional framework for policy formulation, Regulation and operations in the sector. An ICT policy has been developed and declared as a channel and mobilisation to the investment required to accomplish its great ambitions.

In order to improve the effective contribution of ICT and optimise its business benefits, a coherent strategy has been crafted and adopted to ensure the Government of Lesotho (GoL) takes full advantage of new opportunities created by the exploitation of technology and organisational performance is improved through effective ICT investment. The potential impact of new ICT on the efficiency and quality of public services is significant; the ICT strategy that has been developed and published, to enable the entire Government ministry experts to have the systems and information they need to provide a responsive and proactive service to their clients and business partners locally, regionally and internationally.

The strategy enables managers and staff to make informed and effective decisions in a timely and efficient manner. Any investment in systems and technology must be well managed and supported by robust business cases which can demonstrate a real benefit to Lesotho as the deployment of technology and systems in an unstructured way (technology for technology's sake) will simply mean that GoL gains new hardware and software but that the underlying processes remain unchanged and no efficiencies are gained.

### 2.1 Context

The Government of Lesotho formulate the government's budget annually for every financial fiscal year of the government business, taking into account the full impact of government spending on the way government services are delivered. The budget has to deal directly with the impact of ICT best practice and ICT government services deliveries, in addition to reliable Infrastructure-Government best practice that will help to take Basotho nation much further, faster and with greater efficiency, in parallel with economic growth. It has to be modelled around other countries around the world, African continent and institutions that have had successes, and yet be tailored specifically to Lesotho's economy and culture.

The ICT government services delivery should foster accuracy, efficiency, accountability, security, state-of-the-art education, minimisation of fraud, and a healthy population, as well as easier, faster access to government provision for the entire nation. These should be supported by a robust and reliable infrastructure, which should have adequate speed, sufficient capacity, and secure networks and data centre, all of which can be maintained by

qualified Basotho staff, and which will allow full access to all Basotho. Mr John Maphephe as an independent ICT advisor to Government of Lesotho has been part of both International, regional and local team of experts from 2006 to 2011 providing of ICT technical advisory support. It is against this background that some of the interesting methodologies, project management challenging lessons and experiences are recorded for the future of Lesotho. These lessons may have relevance to many developing countries, including those on the African continent.

## 3. RESEARCH METHODOLOGY

The purpose of this exploratory research is to understand the extent and complete implementation of ICT policies and strategies in Lesotho from the perspectives of profit and business driven initiatives, Government driven Service delivery. When undertaking research, it is essential to make use of a structured research methodology to ensure the research has integrity (i.e. that it is reliable, valid and can be "reproduced") [4]. The approach was more of a fact finding tasks to ensure that accurate and comprehensive data was available. Researching the current and future demand in Lesotho markets and across all market segments was the key on evaluating and benchmarking the recorded progress. According to [4], a research methodology is an operational framework in which the facts are placed so that their meaning may be seen more clearly. The region of interest for this study was Lesotho. The parameter of interest is perceived extent and perceived progress made out of ICT policies and strategies towards the complete implementation. Some data was collected using direct personal engagement through semi-structured interviews with more 15 stakeholders from Cabinet members, Principal Secretaries, Directors, Managers, Team leaders and departmental end users.

### 3.1 Source of Information

In this study, key documents reviewed and analysed included the following:

- ICT for Lesotho final version 04<sup>th</sup> March 2005,
- Consultancy to assist the NAO to perform a quality audit and to resolve issues concerning the IFMIS (Integrated Financial Management Information System)
- National Strategy broadband strategy final report 08<sup>th</sup> June 2012,
- Consultancy Review of the Management and Operation of all MFDP ICT Systems Final 15<sup>th</sup> August 2011
- Guide to ICT Policy in IST-Africa Partner Countries v2.2 20 April 2012
- Review of Lesotho Government ICT 30 November 2011,
- Lesotho Science and technology Policy 03-03-2006 – 2011
- Development of an MFDP ICT security policy 28<sup>th</sup> May 2007
- Lesotho 2020 vision Document
- Poverty Reduction strategy document.
- A Diagnostic Review to Determine the Status of ICT Development for Lesotho Government through the Ministry of Finance and Development Planning May 2011.



- Final draft Information and Communication Technology Research & Development and Innovation Strategy by the Department of Science and Technology Republic of South Africa.( Version 71204 version 4A 2007).
- Science and Technology Policy for Botswana 2011
- Republic of Kenya Ministry of Science and technology science technology and innovation policy and strategy 2008.

Key stakeholders from Lesotho were consulted in order to gather ideas and recommendation on the review of the ICT policy implementation. The following stakeholders were consulted;

- |  |                                       |
|--|---------------------------------------|
| • Finance and Development Planning       | • Education Universities and Colleges |
| • Statistics                             | • Local Government                    |
| • Central Bank of Lesotho                | • National ID System Unit             |
| • Financial Intelligence Unit            | • Home Affairs – Immigration          |
| • Communications, Science and Technology | • Public Service and Cabinet          |
| • Independent Elections Commission       | • Police                              |
| • Lesotho Communications Authority       | • Correctional Services               |
| • Public Works                           | • Anti-Corruption Unit                |
| • Traffic                                | • High Court Registrar                |
| • Health                                 | • Natural Resources                   |
| • Defence                                | • LRA                                 |
| • Tourism                                |                                       |

The desk survey was used to review the existing policies and strategies of the mentioned countries. In the final stage, the Benchmarking analysis of the ICT policy cycle (formulation, implementation and review process) in Lesotho was considered against experiences of three relatively successful countries namely Republic of South Africa, Botswana and Kenya. The originating aspects of this work are discussed within the context of:

- The policy and strategy development process and stakeholders involvement
- The ICT policy goals, strategy, objectives and mission
- ICT policy focal areas ,Institutional arrangements driving the ICT policy development and implementation ,African regional dimensions and implementation process made
- Policy monitoring, evaluation and review.

#### 4. REGIONAL BENCHMARKING AS GUIDING TOOL FOR SUCCESSFUL IMPLEMENTATION OF ICT POLICY AND STRATEGY IN LESOTHO.

[8]Benchmarking has recently achieved a major importance as a support tool for policy-making, in particular at the EU level and in the context of the Lisbon process. Benchmarking has become a common tool in policy support, especially in the most innovative policy fields where institutional learning is of outstanding importance. In the field of Information Society, policy-makers need data to measure the impact of the very significant investments in ICT infrastructure and applications which have become the norm across Europe. At the regional level, huge investments are common place but there are hardly any statistical data to evaluate them in the required depth. Benchmarking has different meaning depending on the institutional and organization set-up in which it is applied. It can be used to measure the success factors of a policy towards developing an ICT society [11].

There are several regional benchmarking options that includes the bottom-up approach, top down approach, horizontal approach etc. In the bottom-up approach, regions get together and agree among themselves on a set of common indicators. Since the region has different policy framework, it is not possible to apply the method initially. The choice of indicators is a result of a compromise among different regions without top-bottom coordination. This implies that the same indicator can measure different parameter in different regions for example a measure of policy output, results, and impacts, or a simple framework of readiness indicator could be adopted [8].

Benchmarking can have a very different meaning according to the institutional and political set-up where it is applied. When used in relation to target-related policies, such as the Lisbon strategy, benchmarking can be used to measure the success of policies towards developing the Information Society. On the other hand, where there are no quantitative targets defined by policy-makers, the role of benchmarking is much fuzzier. Furthermore, it makes much difference if benchmarking is a result of a top-down or a bottom-up effort. Benchmarking eEurope is coordinated by the European Commission as an “open method of coordination” to measure and stimulate activities of member states.

In this case, benchmarking acts within the political scope of the eEurope action plan and in order to measure (and stimulate) eEurope policy objectives. Benchmarking eEurope does not address the relevance of the objectives of the eEurope action plan, but rather accepts them as given. This means that here, benchmarking is not a tool to evaluate the policy design but the policy implementation and the attainment of its objectives. Benchmarking in this case acts after policy vision and challenges have been developed, according to which indicators relevant to the policy are defined and agreed upon. [8].

A different situation applies if regional benchmarking is devised through a bottom-up approach, where regions get together to agree between themselves on sets of common indicators. In the UNDERSTAND initiative, partner regions have no common policy framework, so benchmarking is not applied in the way of an operationalisation of specific policy objectives. The choices of indicators are a result of a compromise among different regions without any coordination from top down. This approach also reflects the fact that EU regions have different powers in different domains, which is mostly a result of different national policy systems:

Some regions can act on the education or health system where others cannot. That means that measurement of; for example, the availability of PCs in schools or the usage by citizens of E-health services can be highly relevant for policy-making in one region, while it is of little direct value in others. This also implies that the same indicator can measure different things in different regions: It can be a measure of policy output, results, and impacts, or it can be a simple framework / readiness indicator only. The fibre optics network's length is an output policy indicator for Emilia-Romagna, which has a project to put down new fibre, but a framework[8].

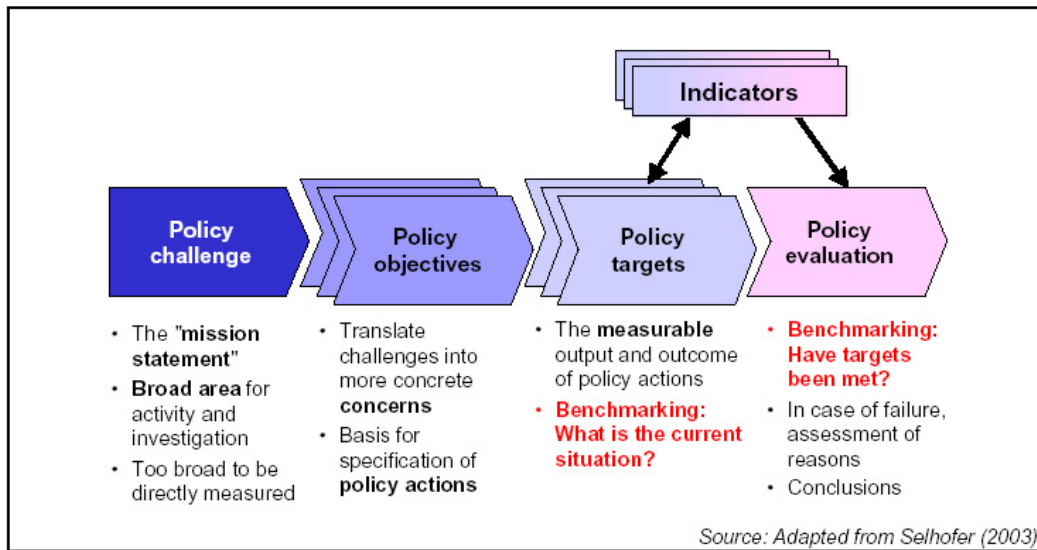


Figure: 1 The different roles of benchmarking in policy-making

This means that the role of benchmarking at the regional level is not simply to measure the attainment of policy objectives (policy evaluation), but it can also have a direct impact on the policy design (prescription) [11]. Ultimately, and paradoxically, it could lead partner regions to have not only common indicators, but similar policies as well! For example, if a region with no policy priority on broadband finds out that it has much less fibre optics coverage than other EU regions; it might find it necessary to introduce it as a new political priority

##### 5. LESOTHO EXPERIENCES FROM INTRODUCTION TO IMPLEMENTATION OF ICT PROJECTS 2007-2013.

The Government of Lesotho [5] with financial support from the European Union (EU) started in 2006 the process to acquire and install an Integrated Financial Management Information System (IFMIS). Maphephe (2011b:3) to this end it is planned to integrate, migrate the local area network to the new national data centres within the entire government ministries. In May 2008- 2011, Lesotho government received an additional international funding to support the implementation of ICT development.

There are many challenges that the country had experienced in the implementation of a policy of this magnitude[7]. The Ministry of Finance and Development Planning (MFDP) between 2010- 2011 jointly used to be the central coordinating in charge of: directing Lesotho's overall economic and development policy; collecting and keeping a record of all revenues and expenditures; accounting to Parliament for the use of public funds; maintaining a record of all government assets; collecting population, social, economic and financial statistics, maintaining the national statistical database; and formulating national manpower policies and plans. [7]

To this end the Government of Lesotho (GoL) through the two ministries (Minister of Communications, Science and Technology AND Ministry of Finance) executed an Integrated Financial Management Information System (IFMIS) and Lesotho Government Data Network (LGDN), to capture and process government financial transactions. The GoL commissioned and invested in a single, standardised, shared infrastructure, accessible, secure and inter-connected through a centralised management.

To this end the Ministry of Finance and Ministry of Communications, Science and Technology have embarked upon implementation ICT policy and strategy for Lesotho Government. This incorporates a large-scale work programme to support the GoL objective of providing world class ICT services to enable Government and citizens alike. For example the IFMIS system has now been implemented, Production of E-passport Service, albeit subject to final user acceptance testing in all GoL Ministries running across the Lesotho Government Data Network (LGDN). In addition, the Government of Lesotho have reorganised the support operations and are implementing their ICT Strategy[7].

[7]A number of operational procedures have been developed and the support is provided through a Help Desk within Ministries, functioning of email and Internet connectivity through the entire GoL, procurement of software & hardware and Data centre at Ministry of Communications Science and Technology. An Information Security Management System Policy (ISMS) is also being developed with (MCST) to ensure security of data through adherence to controls and the Plan Do Check Act requirements of ISO27001.[7] The current ISMS, still in progress, is the result of 5 years Information Security Consultancy provided to Ministry of Finance. It therefore represents a considerable investment in monetary and human resources input and this review was commissioned to advice on how to ensure the potential benefits as well as achievements to date are secured.

Ministry of Communication, Science and Technology (MCST) is responsible for the management of the Government wide data network, data centres and a number of Government wide initiatives including the implementation of the Government e-mail system. However, there are opportunities within the entire Government ministries to improve their performances, as to attract the attention of the GoL Cabinet members, Parliament members, civil societies, International donor community, Private business sector and Lesotho Judiciary services.

The current communications network within Lesotho Government Data Network is found to be generally fit for purpose and more than capable of supporting a full range of Government service deliveries. The availability of dark fibre for the connectivity between government buildings in Lesotho provides a massive bandwidth capability. As articulated [5] that; A successful ICT strategy must be in line with the organisation's business strategy. In defining the strategy, the key requirements have been drawn from the Business and Information System Needs report which was produced during reporting phases of many ICT consultancy review, submitted to the Government of Lesotho ICT projects through consultations and input from all Government Departments. The ICT strategy supports and assists in the delivery of government's business objectives over the next 3 to 5 years.

The ICT Policy and strategy identifies the implementation roadmap by translating the business strategy and considering the three building blocks:

- Applications; Automating of business processes and production of quality reports
- Technology; Confidential, integrity, accessible, functioning and reliable infrastructure
- Organisation, Fully fleshed ICT organisational structure that support business objectives
- ICT as tool to grow Lesotho economy and Lesotho to become a knowledge society.

## **6. BENCHMARKING ICT POLICY VISION, STRATEGY MISSIONS AND OBJECTIVES OF SELECTED COUNTRIES COMPARED TO THE LESOTHO'S**

[5]The policy vision, strategy, mission and objectives of Kenya, South Africa and Botswana emphasize addressing citizen problems which are similar to those of Lesotho. Furthermore, countries like Namibia and Tanzania have provided milestones in the policy. In Malaysia, the State has a vision to utilize ICT to transform successively to an information society, a knowledge society and finally a values-based knowledge society [Malaysia ICTpolicy]. In Mauritius, the policy vision on making use of the ICT as the fifth pillar of the economy and transforming the country to a regional ICT hub [Mauritius ICTpolicy]. Lesotho's Roadmap to the Information Society is based on a number of guiding principles, including the need for high level of political commitment and proactive leadership if the necessary investment required to achieve policy goals and strategies is to be secured. Clearly good governance and a commitment to freedom of the press, freedom of information and an independent media are part of that commitment. It is worth noting that these principles are supported by the Media Policy (19 August 2009) and Communications Policy 2008, which builds on the Telecommunications policy of 1999 and 2005 ICT Policy.

### **6.1 The overall ICT Policy Goals are to**

- Increase wealth creation and improve quality of life through adoption and use of ICT
- Promote ICT literacy and affordable, universal access to ICT products and services
- Coordinate national ICT implementation & development of human resource capacity
- Develop standard, practices and guidelines to support ICT deployment & exploitation
- Provide mechanisms for empowering local participation in the ICT sector

### **6.2 The overall ICT Policy Objectives are to:**

- Achieve buy-in by all stakeholders of the importance of ICT for national development
- Facilitate deployment of national broadband backbone to enable ICT service delivery
- Mobilise resources and establish financing mechanisms to realise ICT policy goals
- Promote development of local ICT products & services, access to public domain data Strengthen existing ICT institutional, legal and regulatory framework
- Promote collaboration and coordination at national, regional and international levels

- a) Eight key strategies have been defined to drive development of the Information Society and Knowledge Economy in Lesotho. The policy states that "Government, as a leader, in collaboration with other stakeholders, is committed to the following overall strategies Establishing legal and institutional mechanisms to ensure the successful implementation of the ICT policy
- b) Providing leadership in ICT development
- c) Investing in ICT education and human resource development
- d) Encouraging the production and wide distribution of local multi-media content
- e) Promoting the growth of the private sector
- f) Ensuring universal access to ICTs.
- g) Guiding infrastructure expansion need to support the delivery of ICTs
- h) Promoting regional and international cooperation"

The roles of each key stakeholder are then briefly defined. Government's role is defined as providing "the vision and policy with a legal and regulatory framework that will guide the activities of all stakeholders". However, it is acknowledged that government "must also play a key role in channelling resources to invest in supporting infrastructures for ICTs in partnership with national and regional businesses and development partners". The Regulator is responsible for monitoring "market demand and supply capacity of service providers and shall intervene to correct imbalances or market distortions in favour of users".

While the Regulator (whose mandate is limited to regulation of Telecommunications, Information and [5]Communication Technologies, Broadcasting, Radio frequency and Postal Services) is accountable to the Ministry of Communications, Science and Technology, it has statutory independence to ensure impartiality, flexibility and transparency. The Private Sector (Business and Industry) is responsible for developing and expanding ICT infrastructure and providing ICT services and products. It is also called upon to improve product and services quality to ensure global competitiveness (as this is key to attracting Foreign Inward Investment as well as achieving export sales which is critical for the Lesotho economy).

The Private Sector is also seen as having a key role supporting the government in achieving wider digital literacy and development of ICT human resource capacity. The Education Sector is responsible for including ICT literacy as part of core curricula in schools and universities, and leveraging ICT to both improve access to and improve quality of available education in Lesotho so as to develop an ICT literate society capable of producing local ICT products and services. Civil Society has the role of identifying societal needs for ICT products and services, improving access to these products and services and promoting ICT adoption in Lesotho. Finally International Organisations and Development Partners have been identified as having a key supporting role, working with the Government of Lesotho to secure necessary financial and technical support for ICT projects and programmes.

The government will promote technology transfer and become actively involved in ICT international forums. Finally there are 10 cross cutting catalysts were selected by the Ministry of Communications, Science and Technology to ensure ICT policy achieves the Government's broader development goals, ICT and Supporting Infrastructure, Education and Human Resource Development Enabling Legal and Regulatory Framework, Rapid Delivery of ICT Services-Government, E-Commerce, Health, Agriculture and Food Security, Tourism, the Environment and Natural Resources and Gender and Youth

Lesotho is partial aligned to the following vision statement: The Vision "is to create a knowledge-based society fully integrated in the global economy by 2020", This vision statement has the following limitation;[5] The vision statement is directed towards the utilization of ICT for accelerating knowledge based society. It is too expensive for Lesotho to achieves this vision for now [6]. Stakeholders consulted during information gathering from information sources of the study had a common message that there is need for intervention on broadband pricing and regulation of wholesale market. Some of the Internet Service Providers felt that they were completely priced out of the market by the high wholesaler prices charged by the incubator operator which then competed directly with them in the retail market. From the regional benchmarking there is fair competitions, regulatory laws and private sector is leading the implementation while government being the main regulator.

Adherence to operational procedures the objective: was to confirm that operational procedures and change control processes are followed and that the operational procedures reflect current operational practice. The method: assess operational procedures being carried out including but not limited to observation of tasks and examination of logs and other relevant records. The detailed findings and information was obtained during interview. [2]The three countries namely Kenya, South Africa and Botswana demonstrated a very good record keeping and following operational procedures management and other supervising staff are mentored in respect of discharging their managerial and supervisory responsibilities. Each distinct service head is assisted to identify their key performance indicators, understand their service deliverables and know who their customers are.[9] Once customers are identified, the relationship must develop. Essential that dialogue is established and the concerns of customers can be addressed to manage their expectations.

A culture of management information should be fostered to ensure that management is routinely informed on a frequent, if not daily basis, of the Key Performance Indicators in their area of responsibility. Maintenance and Application support initial objective: Assess the local support provision; Effectiveness of change management; Responsiveness and resolution timescales of Third party external software supplier support; Future capability/capacity of Third party external software supplier support. [9] Perception of effectiveness of Third party external software supplier support. The Corporate and Information Governance management in this area must be improved.

Responsiveness and resolution of third party external software suppliers is not being actively managed. It is one of the strongest pillars for South Africa and Botswana hence why there is a significant progress in the implementation of ICT policies and strategies. The future capability and capacity of third party suppliers is not being actively managed in Lesotho as there is no specialist ICT Contracts Manager to liaise with the external suppliers.

Implementation approach e.g. project boards, project management, Objective: Assess ICT stake holder's perceptions of key areas such as training effectiveness, project management, and user involvement in relation to system implementation.[3] Method of approach was on the site review of available documentation, staff interviews and workshops. Elements of good project management practice are being used in areas such as the implementation of OAS, and these should be encouraged. In particular the involvement of end users. Benchmarking with this three successful ICT policy in selected states in the region, user involvements, technical equipments, and adequate budget have been in place as part of project implementation. The adoption of a proven project management methodology will ensure that such areas as communication, training and risks are fully considered. Many staff has strong feelings about IFMIS and there needs to be a co-ordinated approach to address the concerns, myths and misconceptions expressed from various report [9].

## 7. PROGRESS IN IMPLEMENTING THE ICT POLICIES & STRATEGIES TO DATE

(IST-Africa Consortium 2012:55) the Government of Lesotho has developed a comprehensive ICT Policy and good strategies, which when fully implemented will significantly impact on the socio-economic development of the country. There are clearly areas of overlap between the cross-cutting catalysts, whereby collaboration with the private sector on common policy measures, instrument and initiatives would have a very significant, positive impact on rolling out parallel initiatives more quickly. It also seems clear that addressing some problems at a cross-border level would offer significant advantages including potential cost savings when rolling out solutions at a national level. This is particularly the case for countries addressing common problems.

It is now over a period of 6 years after the adoption of the ICT Policy and strategy, the ICT government programmes were still largely stuck at the stage of static information provision, although limited progress has been made in the various spheres of government towards the interactive and transactional stages. An example of the interactive phase is that of enabling Business Suppliers and owners who have submitted for payments, Traders Licenses, private emails to senior government employees, tenders, ministry of educations and Land Administration to monitor progress on the approval of plans online and to interact with the responsible unit to address any obstacles in this process.[9] In general terms, the ICT policy leads to an implementation plan benchmarked by flagship projects, although the presence of an implementation plan may not guarantee the success of policy.

A review of the situation of Lesotho shows that the implementation of the ICT policy is driven by external funding more than a well thought-out plan that addresses the key building blocks like infrastructure, regulatory functions and human resources development as envisaged and monitored.

## 8. CONCLUSIONS

[1]The effective uptake and utilisation of ICT have made a demonstrable impact on economic progress and there are clear indications of ICT's positive impact on development. Effective uptake requires investment in Research and Development, innovation and human capital development, both mid-level and high-level ICT skills, to create the requisite absorptive capacity in the economy, and requires that technology be created or adapted to address the specific challenges arising from Lesotho context [1]. The World Summit on the Information Society [12] identified the central role that science and the sharing of research results play in the development of the information society; the need for international and regional cooperation in creating an inclusive information society; and the role of education, knowledge, information and communication in relation to human progress, endeavour and well-being [12].

ICT has been identified as key tool towards Lesotho becoming a fully integrated member of the Information Society by the former **Minister of Communications, Science and Technology Dr. Motsotsoe Thomas Thabane in March 2005**. The analysis of the Lesotho national policy and strategy deployment and implementation has been carried out. Weaknesses were identified through the Benchmark approach taken to analyze and compare the Lesotho from other countries of similar nature but in the same regions. It is evident that from the start of the initiatives, drafting and development of the policy stakeholders took a backbencher role, thus leading to:

- Lack of ownership, direction, resources, and operational institutional framework
- Poor participation of key stakeholders
- Poor coordination during implementation
- Lack of coherent but integrated implementation strategies
- Lack of unified approach towards the implementation

[11] In order to correct the situation, the policy review process has to consider changes in technology, new national and regional developments and recognize the evolving of new acts and policies. A good policy with its implementation strategies and institutional framework has the potential of making ICT an effective tool in achieving countries development goals.

For an effective policy review process it is recommended that:

- The review of the ICT policy should involve all stakeholders emphasizing a multi-stakeholder participatory approach involving key ministries, private sector, civil society and international participation.
- The policy has to appreciate such other laws and regulations like cyber usage, e-transaction, confidentiality and privacy.

- The reviewed policy has to emphasize downstream issues like ICT Incubator to promote local entrepreneurial culture.

By using the benchmarking principals Lesotho was analysed and compared to other countries. The emerging issues from the work and the entailing findings are categorized in the following key elements summarized as:

- The policy process and stakeholders involvement
- The ICT policy goals, objectives and mission
- ICT policy focus areas
- Institutional arrangements for driving the ICT policy
- Regional dimensions ( Kenya, Botswana and South Africa)
- Implementation processes
- Policy review and monitoring

[10]Institutional framework for implementing the national policy implementation and monitoring was not described adequately in the policy; hence some roles were left hanging. It is observed that all the stakeholders consulted strongly feel that the policy left a serious governance gap. [10]Most of the stakeholders interviewed agreed that, coordination of the implementation strategy was inadequate and therefore created confusion on what have to be done and what should be the source of funding for the proposed activities.

#### ACKNOWLEDGMENTS

The article will like to acknowledge the contribution made by Independent ICT consultancy firms namely, Capita Helm, Analysys Mason from UK, Soft Tech from Tanzania, and Mr Masiu Khiba who is Director of ICT from Ministry of Communications Science and Technology, Mrs Tholoana Masupha who is Information Systems Manager from the Ministry of Finance, Lesotho Senior ICT Experts, Lesotho ICT suppliers and IPS. Mr Ntoi Deputy Principal from the Ministry Planning and Development, Mr Pheko Lerotholi Principal Secretary, Ministry of Planning and Development and finally Lesotho Government throughout its entire resource.

#### REFERENCES

- [1] Cohen, W. and Levinthal, D. (1990). Absorptive capacity: A new perspective on learning and innovation. *Administrative Science Quarterly* 35(1): 128–152.
- [2] Department of Science and Technology, (2007) Final draft Information and Communication Technology Research & Development and Innovation Strategy; Available [www.ist-africa.org](http://www.ist-africa.org) [accessed on the 05 December 2013].
- [3] Government of Botswana, (2011) Science and Technology Policy for Botswana. available [www.ist-africa.org](http://www.ist-africa.org) [accessed on the 02 December 2013].
- [4] Leedy, P.D. and Ormrod, J.E. (2010). *Practical Research: Planning and Design*, 9th ed. Boston: Pearson.
- [5] Lesotho Government ICT Policy, (2005). ICT Policy for Lesotho Government; Presented by the former Minister and member of Lesotho Parliament Dr. Motsoshe Thomas Thabane, Minister of Communications, Science and Technology 04<sup>th</sup> March 2005, Maseru Lesotho Available [www.gov.ls](http://www.gov.ls) [accessed 10 October 2013].
- [6] Murry, M. & Haigh, T. (2012) *Development of National Broadband strategy for Lesotho*, Analysys Mason: Maseru.
- [7] Maphophe, J. (2011) *Government of Lesotho Diagnostic review on the status of ICT systems*.
- [8] OSIMO, D., AND GAREIS, K. 2005. The role of inter-regional benchmarking in the policy-making process: experiences in the field of information society, In proceedings of the Regional Studies Association conference, Aalborg, Denmark.
- [9] Republic of Kenya ministry of science and technology science, (2008) *technology and innovation policy and strategy*: available [www.ist-africa.org](http://www.ist-africa.org) [accessed on the 06 December 2013].
- [10] Remenyi, D and Williams, d. (1995) "Some Aspects of Methodology for Research in Information Systems," *Journal of Information Technology*, vol. 10(1) 191-201, 1995.
- [11] Twaakyondo, Hashim M. (2011) *Key Issues in Information Communication Technology Policy Review Process: The Case of Tanzania*. *Journal of Computing and ICT Research*, Vol. 5 (2) 46-58.
- [12] WSIS (World Summit on the Information Society) (2003). *Declaration of principles. Building the Information Society – A global challenge in the new millennium* Available [www.itu.int/wsis/docs](http://www.itu.int/wsis/docs) [accessed 04 June 2013].

# A NOVEL DOUBLE GATE FINFET TRANSISTOR: OPTIMIZED POWER AND PERFORMANCE ANALYSIS FOR EMERGING NANOTECHNOLOGIES

**Aditya Dayal**

Research Scholar

ITM University, Gwalior, India

Email: adityadayal2008@yahoo.com

**Shyam Akashe**

Associate Professor

ITM University, Gwalior, India

Email: shyam.akashe@yahoo.com

---

## ABSTRACT

Abstract—FinFET technology has been proposed as a promising alternative for deep sub-micron CMOS technology, because of its superior device performance, scalability, lower leakage power consumption and cost-effective fabrication process. Fin-type field-effect transistors (FinFETs) are capable substitutes for bulk CMOS at the nano-scale. Previous works have studied the performance or power advantages of FinFET circuits over bulk CMOS circuits. This paper elucidates the dependability analysis of Average power, Leakage power, Leakage current and Delay of AND gate using double gate FinFET. Our experiments compare FinFET circuits at different voltages at 45 nm technology in virtuoso tool of cadence, showing that DG FinFET circuits have better dependability and scalability.

Keywords—double gate FinFET; fin width; low power circuit; device analysis

---

## 1. INTRODUCTION

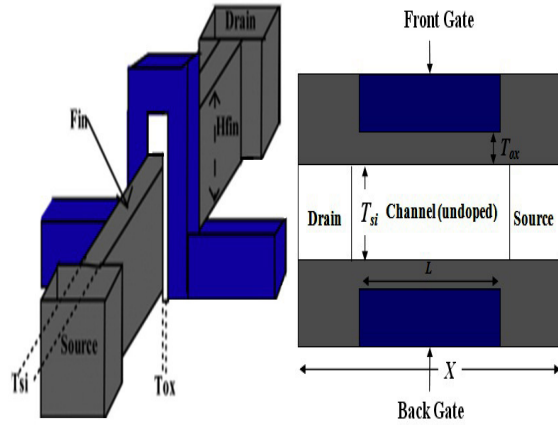
FinFET devices have been proposed as the most likely candidate to substitute bulk MOSFETs for ultimate scaling [1]. The FinFET devices can be employed either with two gates tied together [a three-terminal (3T) structure] or with two independently biased gates [a four-terminal (4T) structure] [2]. The ITRS has proposed multi-gate FETs such as planar double gate FETs and FinFETs as a possible scaling path for low power and high performance CMOS technologies [3]. Although early double-gate FETs presented manufacturing challenges associated with vertical structures, more recently, double-gate devices called FinFETs or wraparound FETs that are compatible with standard CMOS over most of their processing steps have been demonstrated [4].

The channel of a FinFET is a slab (fin) of undoped silicon perpendicular to the substrate. At least two sides of the fin are wrapped around by oxide simultaneously. In this way, the active regions are broken up into several fins and a gate overlaps the channel regions of the fins on either side. Consequently, the increased electrostatic control of the gate over the channel makes very high  $I_{on}/I_{off}$  ratios achievable. FinFETs have also shown excellent scalability, suppression of short channel effects, and limited parametric variations. A FinFET with independent gates is a novel variant of double gate devices. Two isolated gates are designed by removing the gate regions at the top of the fin. Although the gates are electrically isolated, their electrostatics is highly coupled.

The threshold voltage of either of the gates can be easily influenced by applying an appropriate voltage to the other gate. This technology is called multiple independent-gate FET (MIGFET) [5] and can be integrated with regular double-gate devices on the same chip. A successful implementation of a FinFET device with three independent gates has also been reported [6].

## 2. DEVICE ARCHITECTURE

Conventional DG-FinFET structure is shown in figure. It is a double gate structure. All the transistors are having tied gates. The channel of a FinFET is a tiny slab (fin) of undoped silicon perpendicular to the substrate. Figure 1 illustrates a simplified perspective 3D and cross-sectional view of a typical double gate FinFET device structure. The source, drain and channel regions are doped with the same type of dopant. Hence, there is no pn junction along the channel length and the leakage current is thus reduced. The undoped channel eliminates Coulomb scattering due to impurities, resulting in higher mobility in FinFETs [7]. The ratio of p-type to n-type mobility is higher than CMOS. Unlike CMOS, threshold voltage is not modified by source-body voltage variation. This, along with improvement in mobility, paves the way for longer series stacked transistors in the pull-up or pull-down networks of logic gates.



**Figure 1: 3D and Cross section view of a typical FinFET**

The gate oxide is formed on both sides of the fin simultaneously, which solves alignment issues of source and drain junctions and simplifies the process. For clarity, the followings are some critical geometrical parameters according to the figure.

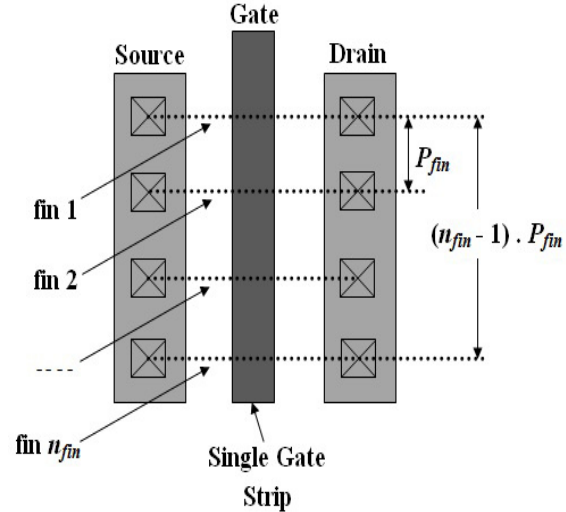
1. Gate length ( $L$ ): the physical gate length of FinFETs, defined by the spacer gap.
2. Fin height ( $H_{fin}$ ): the height of silicon fin.
3. Fin width ( $T_{si}$ ): the thickness of silicon fin, defined by the distance between the front and back gates.
4. Front or back gate thickness ( $T_{ox}$ ): the thickness of the front or back gate oxide.

In FinFET-based circuits, a single-fin device cannot provide sufficient current to meet the performance constraints; hence, wider devices should be employed. In FinFET technology, the width of the device is proportional to the height of the fin. To maintain the mechanical stability, the height of the devices, however, is limited to several times the fin thickness. Therefore, to increase the size of the FinFET devices, multifin devices are used, which are built with several individual fins. Due to process variation, individual fins can have different threshold voltages. The gate work function, channel length, and fin thickness variation are the most important sources of variations in FinFET devices [8]. However, it is not the goal of this paper to discuss the effect of the different sources of threshold voltage variation. In our simulations, we include the effect of average power, leakage power, leakage current and delay on double gate FinFET. The height of the fin,  $H_{fin}$  acts as the width of channel. Stronger devices can be built by using appropriate number of parallel fins in each transistor. So, the channel width of a FinFET device is given by

$$\text{Width} = n_{fin} \times H_{fin} \quad (1)$$

Where  $n_{fin}$  is the number of fins. Taller fins result in more powerful devices, at the cost of granularity in gate width. Other important design parameters are fin thickness  $T_{si}$  and gate-source/drain underlap. Existence of gate-source/drain underlap and small  $T_{si}$  are necessary conditions for good suppression of short channel effects in FinFETs [9]. The ultimate double gate FinFET device uses a physical oxide with a large bandgap to isolate the gate from the conducting channel area.

By applying gate voltage to accumulate or deplete majority carriers in the channel, we can modulate the channel conductance for controlling the channel current as a switch between the source and drain. Let the gate width of a FinFET with a single fin be  $W_{min}$ . As we know that the gate width of a multi-fin FinFET is quantized in the number of fins. The higher values of widths are achieved by connecting a number of fins ( $n_{fin}$ ) in parallel. Figure 2 shows an SG-mode FinFET in which four fins have been connected in parallel. The width of this device is  $4W_{min}$ . The area occupied by this device is proportional to  $(n_{fin} - 1)/P_{fin}$ , where  $P_{fin}$  is the fin pitch defined by the process technology.



**Figure 2: SG-mode FinFET**

To accurate estimation of the leakage current, let us first examine the leakage current of the individual fins. Assuming that the threshold voltage of an individual fin has a normal (Gaussian) distribution  $N(\mu_{VTX}, \sigma_{VTX})$ , its leakage current has a lognormal distribution that is given by the following expression:

$$I_{Leakage} = WI_0 e^{-\frac{V_{TX}}{B}} \quad (2)$$

$$B = m \frac{kT}{q} \quad (3)$$

Where  $V_{TX}$  is the threshold voltage of an individual fin,  $W$  is the width of the single-fin FinFET,  $I_0$  is a technology-dependent parameter and  $m$  is the body factor.  $kT/q$  is the thermal voltage ( $\sim 26$  mV at the room temperature), and  $mkt/q$  is referred to as constant  $B$  for simplicity. The leakage current of a multifin device with four fins is the sum of the leakage currents of the individual fins, as given by the following expression:

$$I_{Leakage} = WI_0 [e^{-\frac{VT1}{B}} + e^{-\frac{VT2}{B}} + e^{-\frac{VT3}{B}} + e^{-\frac{VT4}{B}}] \quad (4)$$

Where  $VT1$ ,  $VT2$ ,  $VT3$ , and  $VT4$  are the threshold voltages of individual fins in the multifin device. In the general case, the leakage current of a multifin device is the sum of  $n$  lognormal variables, where  $n$  is the number of the fins in a multifin device. In FinFET technology, "device widths are dispensed in units of whole fins only." [10]



This is familiar as device width quantization, which bounds our ability to size transistors effectively in FinFET circuit. The fabrication process of double-gate MOSFET devices (e.g., FinFET) is more complicated than that of single gate devices, which will potentially convey more nonuniformity during fabrication. As for example, in FinFET devices that the gate oxide is on the etched sidewall of the fin, thus its uniformity is more difficult to control. The condition of the channel-oxide interface is determined by the sidewall roughness of the fin.

**3. SHORTED-GATE AND INDEPENDENT-GATE FINFETS**

FinFET devices come in many flavors. In shorted-gate (SG) FinFETs, the two gates are tied together, leading to a three-terminal device. This can be of use as a direct replacement for the conventional bulk-CMOS devices. In independent-gate (IG) FinFETs, the top portion of the gate is etched out, giving way to two independent gates. Because the two independent gates can be controlled separately thus IG-mode FinFETs offer more design options.

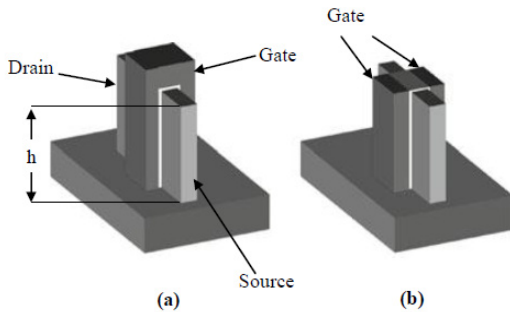


Figure 3. (a) SG-mode FinFET (b) IG-mode FinFET

**4. LOGIC DESIGN IN FINFET TECHNOLOGY**

In this section, we present the logic design of AND gate using double gate FinFET. Figure 4 shows the symbols for independent-gate (IG) and shorted-gate (SG) n-type and p-type DG FinFETs.

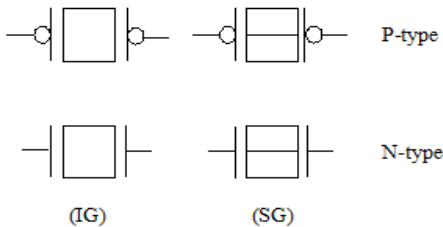


Figure 4. Symbols for independent-gate (IG) and shorted-gate (SG) n-type and p-type double-gate FinFETs.

The proposed AND gate is realized using the virtuoso tool of cadence. The spectre simulator of cadence is used to simulate the output. The circuit implementation of AND gate using double gate FinFET is shown in figure 5. Here the gate of two PMOS or NMOS transistors are shorted to formed a FinFET like structure. In this circuit, the supply voltages are given 0.5 V, 0.6 V, 0.7 V, 0.8 V and 0.9 V respectively at 45 nm technology.

The AND gate is a basic digital logic gate that implements logical conjunction. That behaves according to the truth table shown in Table I. An output HIGH (1) results only if both the inputs to the AND gate are HIGH (1). If neither or only one input to the AND gate is HIGH (1), a LOW (0) output results. In another words, the function of AND (A.B) effectively finds the minimum between two binary digits, just as the OR function finds the maximum. So that the output is always 0 except when all the inputs are 1s.

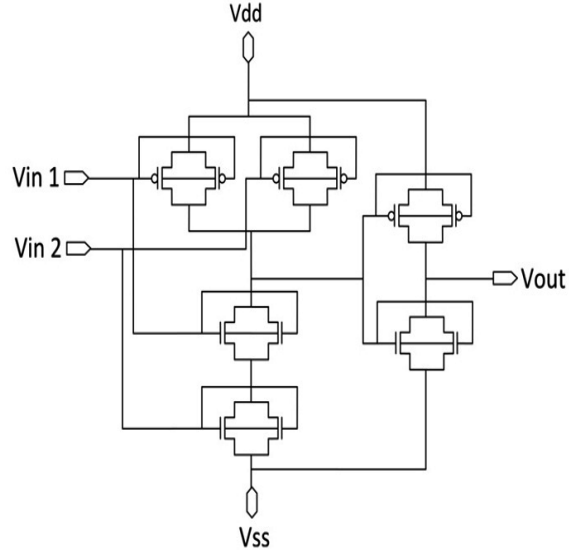


Figure 5. Schematic of AND gate using double gate FinFET.

TABLE I. TRUTH TABLE OF AND GATE

A	B	Output
0	0	0
0	1	0
1	0	0
1	1	1

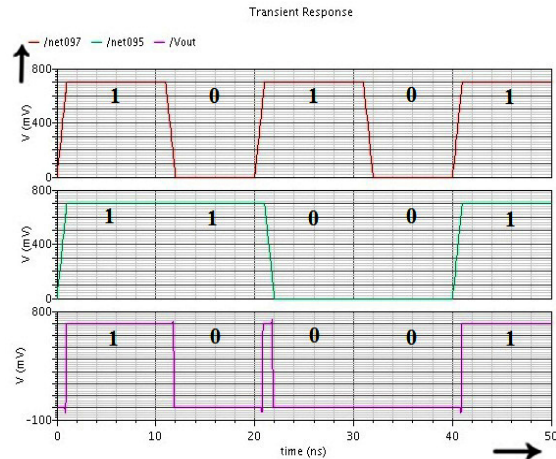


Figure 6. Simulated Transient Response of double Gate FinFET in Cadence Tool.

The input and output waveforms simulated for the AND gate using double gate FinFET is shown in figure 6 and proposed DC response of DG FinFET is shown in figure 7. Cadence simulation of transient analysis and DC analysis gave good results. In order to examine and compare device performance due to process variation, we vary fin width  $t_{Si}$  and gate oxide thickness  $t_{ox}$  as individual parameters and also as different combinations of both.

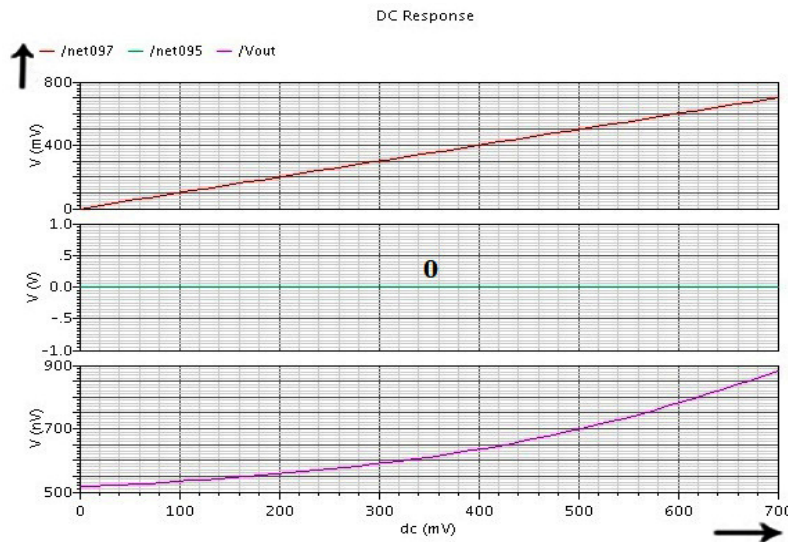


Figure 7. Simulated DC Response of double Gate FinFET in Cadence Tool.

### 5. RESULT AND DISCUSSION

In this section, we present the simulation results of AND gate at 45nm and 180nm technology from virtuoso tool of cadence. Figure 8 and 9 show the simulated leakage power curve of DG FinFET at 0.7 V power supply at 180 nm and 45 nm technology respectively. In 180 nm technology the average power consumption is 10.75 nW whereas in 45 nm technology the average power consumption is 7.467 nW. Our experimental result gives minimum leakage power as compared to 180 nm technology.

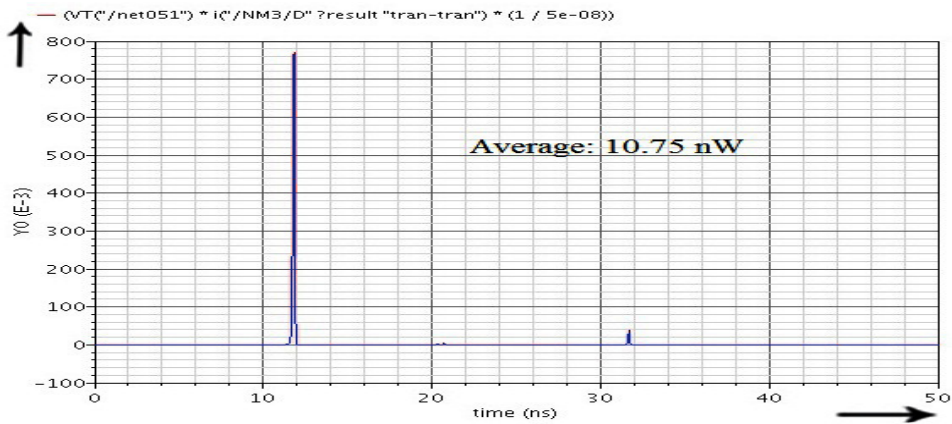


Figure 8. Simulated Leakage power of double Gate FinFET at 180 nm technology in Cadence Tool.