

# DESIGN AND IMPLEMENTATION OF A DIRECTIONAL OBJECT SENSING AND RANGING SYSTEM

Adamu Murtala Zungeru<sup>1</sup>, Idris Mahmood<sup>2</sup>, Anthony Chukwunonso Mmonyi<sup>3</sup>, Gbenga Daniel Obikoya<sup>4</sup>

<sup>1,4</sup>Department of Electrical and Electronics Engineering, Federal University Oye-Ekiti, Nigeria  
[zungeru.adamu@fuoye.edu.ng](mailto:zungeru.adamu@fuoye.edu.ng), [gbenga.obikoya@fuoye.edu.ng](mailto:gbenga.obikoya@fuoye.edu.ng)

<sup>2</sup>Department of Electrical and Electronics Engineering, Federal University of Technology, Minna, Nigeria  
[iidriiz@yahoo.com](mailto:iidriiz@yahoo.com)

<sup>3</sup>Department of Electrical and Electronics Engineering, Afe Babalola University, Ado-Ekiti, Nigeria  
[mac11anthony@gmail.com](mailto:mac11anthony@gmail.com)

## ABSTRACT

The research provides a security system that achieves automatic object sensing detection at a given radius range from the security system. This system provides an automatic detection of intrusion into a restricted property. An ultrasonic range sensor and a stepper motor are interfaced with a microcontroller. The range sensor is mounted on top of a stepper motor which rotates about its axis continuously, and emits a burst of energy until reflected off of an object. When the range sensor senses an object, the angle of the stepper motor at the instance of object detection is recorded by the microcontroller and displayed on a Liquid Crystal Display (LCD) along with the object distance. Because of the rotational motion of the sensing system, it can be concluded that this system is quite different in its approach to security issues as compared to similar ones that which are just stationed in a fixed point and meant to detect obstacle or intrusion from a particular direction.

**Keyword:** Directional Object, Ultrasonic Range Sensor, Stepper Motor, Detection

## 1. Introduction

A quick and immediate detection helps to prevent worst events from happening, without which the world would be in total chaos as things that could ordinarily be avoided will either go unannounced or will be noticed only when it is too late. It is not just enough to know that something happened, but how it happened, when it happened and where it happened. A proactive and preemptive measure can be deployed to avert an event from happening, by making use of directional object sensing and ranging system. This automatic object detection system incorporates the distance and angle of detection. It possess ultrasonic range sensor which works on the principle of RADAR to detect object within its range of coverage.

The history of "Radio Detection and Ranging" goes back to the nineteenth/beginning of the twentieth century. In 1904 a patent for the detection of distant metal objects with electric waves was granted to the German Christian Hülsmeyer. But intensive research only began in the 1930s with the aim of using radar techniques for military applications. During World War II, radar technology and system grew rapidly. In the battle for Britain fought during World War II, Great Britain used the 'Chain Home RADAR' system comprising of 21 early warning RADAR sites to obtain timely warning of the direction and number of German aircraft coming to attack them. They then used this information to focus on their limited number of interceptor aircraft to achieve numerical parity with the attacking aircrafts. As a result, Germany was unable to achieve air superiority and they indefinitely postponed their attack on Great Britain.

In the years following the war, research continued to steadily advance radar capabilities [1]. Since then technologies like Synthetic-Aperture Radar (SAR) and many more have been developed and introduced. Today radar also found its way into many non-military applications (e.g. automotive) and research can be expected to continue [2].

A German physicist Heinrich Hertz showed that radio waves could be reflected from solid objects in 1886. In 1895, a Physicist instructor at the imperial Russian Navy School in Kronstadt, Alexander Popov, developed an apparatus using a coherer tube for detecting distant lightning strikes. The following year, he added a spark-gap transmitter. In 1897, while testing this equipment for communicating between two ships in the Baltic Sea, he observed interference beat caused by the passage of a third ship. Popov wrote in his report that this phenomenon could be used for objects detection. And his observation, though he made no further attempt to do anything about

it, has formed the basis of the advancements that has been recorded in object detection and ranging system by various scientists since the beginning of the 20<sup>th</sup> century till date [3].

It is worthy of note that the British were the first to fully exploit RADAR as a defense against aircraft attack. Robert Wattson discovered the object detection capability of the death rays the British scientists were originally tasked to investigate, through the propagation of electromagnetic energy, by the defense ministry. And this served as the basis for the Chain Home network of radars to defend the Great Britain, which defended approaching German aircraft in the Battle of Britain in 1940 [4], [5], [6].

In late 1941 *Popular Mechanics* had an article in which a United State (U.S) scientist speculated about the British early warning system on the English coast and came close to what it was and how it worked. Alfred Lee Loomis organized the Radiation Laboratory at Cambridge, Massachusetts which developed the technology in the years 1941 – 1945 [6], [7].

The war precipitated research to find better resolution, more portability, and more features for radar including complementary navigation system like Oboe used by the RAF's pathfinder [8].

In 1999, Innovation Sensor Technology (InnoSenT) was the first manufacturer of planar and highly integrated low cost radar module based on Field Effect Transistor (FET) oscillator technology, which replaced the common waveguide with Gunn Oscillator at that time. Today, InnoSenT produces more than one million, five hundred thousand radar per annum, for commercial, automotive and industrial application with increasing functionality, complexity and significant growth [9].

Aloysius Wehr and Uwe Lohr (1999), measure the range and reflectance of objects from the surface of the earth using an Airborne Laser Scanner (ALS), of which position (distance) and orientation (scanning angle) were determined after application of different scanning mechanism and integration of laser with GPS and INS [10].

Vicent Tao (2001) was capable of inspecting transportation object from mobile mapping image sequences in an automatic and efficient manner. Due to complexity, the approach here deals with transportation objects with known location information which was derived from an existing database and with vertical line features such as traffic signs, street light poles and so on. Success rate of the approach in this paper was over 90 percent based on the test data that were gathered, though the research could be improved if the majority of the manual work could be replaced by an automatic approach in order to save both time and cost [11].

Lorenz et al. (2001) developed a Cassini RADAR which was operated both in scatterometric and radiometric modes during the Venus 1 and Earth swing-by to verify its functionality. At Venus, only the thermal emission from the thick absorbing atmosphere was detected while at the Earth, both the RADAR echo and the microwave emission from the ocean surface disturbances, the rough, high and cold mountains and so on were detected. The instrument functionality appears to be excellent and could perform well for the Saturnian system [12].

Viet Thuy Vu, Thomas Sjogren, Mats Petterson, Anders Gustavsson and Lars Ulander (2010) present a detection of moving targets both theoretically by focusing in Ultrawide Band (UWB) Synthetic Aperture Radar (SAR) and experimentally by evaluating the gain in detection ability from the results on single-channel SAR. The results with both simulated (theoretical) and real (experimentally) data show that the ability to detect moving targets increases significantly even when a moving targets are surrounded by a considerable number of stationary targets or clutter. The technique used in this research also showed the ability to estimate Normalised Relative Speed (NRS) and to indicate the existence of acceleration and change in direction [13].

Celestin Twizere (2013) presents the detection of vehicular speed with the aid of Car Radar Gun (CRG) in order to ensure road traffic safety in Rwanda. The Car Radar Gun detected the speed of vehicles by sending out electromagnetic waves to the vehicles, thereafter received the reflected waves and after processing discovered the speed of the vehicle. The research shown that, with the use of CRG, there was road safety improvement as compared to previous years [14].

## 2. Design and Construction

The directional object sensing and ranging system is designed using the block diagram in Figure 1(a) and 1(b)

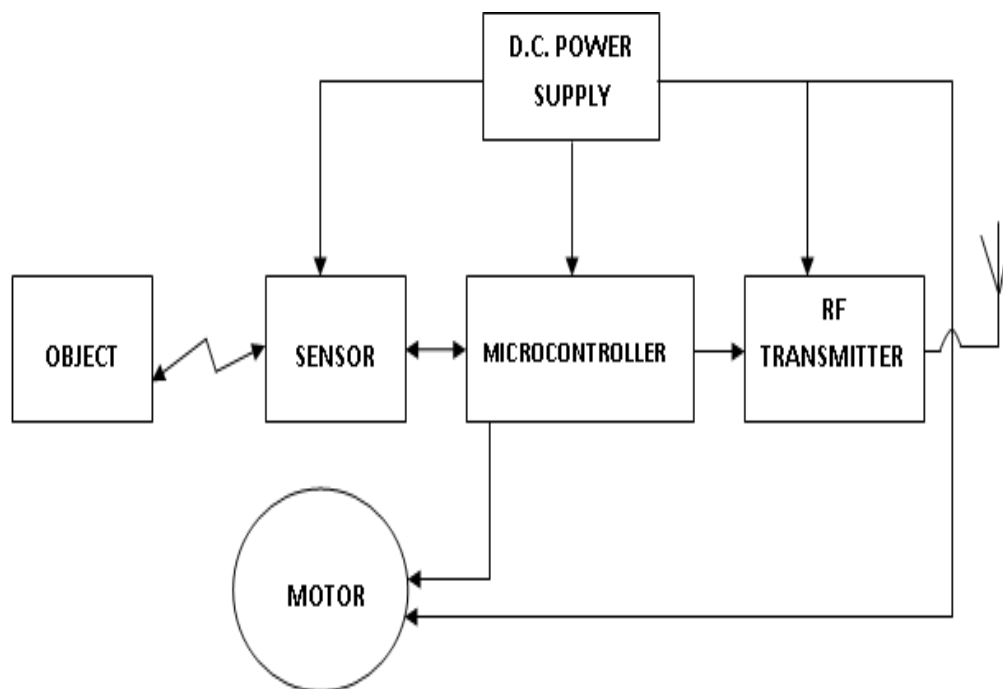

(a) Block Diagram of RF Transmitter Unit

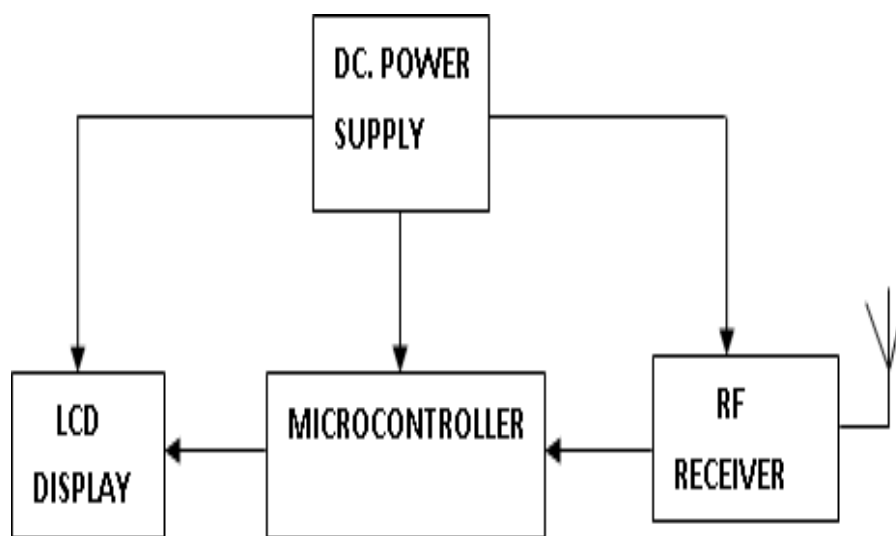

(b) Block Diagram of RF Receiver Unit

**Figure 1:** Block Diagrams of Directional Object Sensing and Ranging System

The system is designed to cover maximum range of 2.5m. Each module of the block diagram of Figure 1(a) and 1(b) are used to realize the design of the system.

**Power Circuit:** The transmitter circuit is powered by an external 12V battery. A reverse blocking diode is placed between the battery's positive terminal and the input filter capacitor so as to protect the circuit components from damage via reverse polarization. The diode is rated at 3A, 100V so that the stepper motor (rated at 1.2A, 12V) will also be protected from reverse polarity by tapping its supply from the cathode of the diode without exceeding the diode's current rating. The 100 $\mu$ F electrolytic input filter capacitor  $C_1$  dampens environmental noise that may be induced in the circuit especially the harmonic effect of the resonating 50Hz power line frequency. See Figure 8 for the complete circuit diagram. Also dampens any inductive voltage spike that may be yielded in the coils of the stepper motor. The capacitive reactance offered to the power line noise is calculated as:

$$X_c = \frac{1}{2\pi fC} = 31.8\Omega$$

Where  $F = 50\text{Hz}$  and  $C = 100\mu\text{F}$ , then,  $X_c = 31.8\Omega$

A 3-Terminal 1A Positive Linear Voltage Regulator 7805 is placed after the input capacitor and it regulates the 12V DC voltage to a steady 5V in its output pin. It outputs sufficient current to supply to the other parts of the circuit. Output capacitor C2 is 100nF ceramic capacitor used as specified in the datasheet of the regulator. It smoothens and stabilizes the output 5V and filters off any transient that the circuit may produce. The power supply for the receiver is similar only with that the 1N5401 reverse blocking diode is replaced with 1N4007 which has a current rating of 1A.

**Reset Circuit:** The RESET of the microcontroller is active low and is the pin 9 of the device. When a low voltage is sensed on pin 9, the microcontroller clears all registers and Static Random Access Memory (SRAM) locations and the CPU starts executing the program from run location 0x00000. The pin is connected to supply voltage via a 10K $\Omega$  pull-up resistor ( $R_2$ ) which serves as a buffer between supply and ground to prevent short circuit. A normally opened switch placed between the reset pin and ground is used to engage manual reset. A 10nF capacitor ( $C_{10}$ ) is used to prevent the reset pin from sensing debouncing of the switch and to filter any circuit noise. The diode  $D_3$  protects the reset pin from being powered by the capacitor when power is OFF.

For manual rest, pressing and depressing the reset button resets the microcontroller.

**Crystal Circuit:** The microcontroller uses an external 16MHz crystal (X1) as clock source connected to its pin 12 and 13. The microcontroller therefore operates at 16 million clocks per seconds and is capable of executing 16 million instructions per seconds. The pins of the crystal are grounded through two 22pF capacitor (C3 and C4). This configuration ensures a full rail-to-rail clock swing and a more powerful clock signal making the device suitable for working in noisy environment.

**Stepper Motor:** The stepper motor driver is connected to the upper nibble of PORTB (PB0 - PB3) of the microcontroller. The motor is a unipolar permanent magnet stepper motor and consist of two coils having three cable endings. Two of the cables of each coil are the used to drive the motor while the remaining ones are connected to the positive power supply. Four TIP41N NPN Silicon Power Transistors are used to drive each coil of the motor. They are rated at 6A, 65W, 40V - 100V and have a gain of 75. This makes them suitable for driving the motor because the rating exceeds the maximum requirement to drive the motor. Each coil of the motor sinks 300mA of current and the transistors should be able to withstand this current drain or risk damage. Each transistor is connected in common emitter mode with their emitters grounded and their collectors connected to the four coil wires. Their bases are connected to the microcontroller via a base resistor. The collector current of each transistor is dependent on the base current.

**Range Sensor:** The range sensor HC-SR04 in Figure 2 is mounted on top of the motor and it detects and measures the speed of object within the radius of 5m from the transmitter unit as it rotates. It operates at 5V and is powered by the 5V regulator's output. The sensor's Trigger and Echo pins are connected to PC0 and PC1 in PORTC of the microcontroller. The microcontroller sends a 10 $\mu\text{s}$  pulse to the trigger pin and the checks to sense when the echo pin becomes high. Once it is high, the microcontroller starts counting until the echo pin becomes low. The count value is then used to calculate the object's distance.

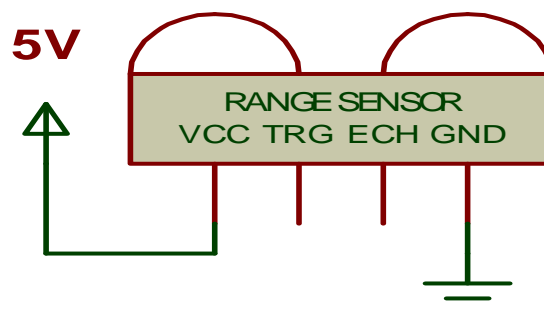

**Figure 2:** Range Sensor

**Tachometer Circuit:** Since the stepper motor is an open loop device, it does not give any feedback information as to its current position. To compensate for this, an encoder is attached to it so that as it rotates, the angle of rotation can be obtained by measuring the angle of its blade's deviation from the encoder.

The encoder is built as a contactless device and acts as an optical encoder by using light to sense the speed. An infrared Light Emitting Diode LED was used as the light source in order to reduce the effect of ambient light on the device since the operation of ordinary LEDs are greatly affected by ambient light. The infrared LEDs are always ON and are constantly emitting light. The circuit consists of the infrared sender and receiver circuits. The sender circuit is shown in Figure 3.

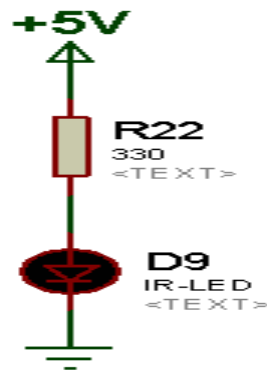

**Figure 3:** Infrared Sender Circuit

The circuit consists of the infrared LED (IR LED), a current limiting resistor and power supply. The receiver circuit is built around the LM358 high gain operational amplifier which acts as a comparator. The circuit is as shown in Figure 4.

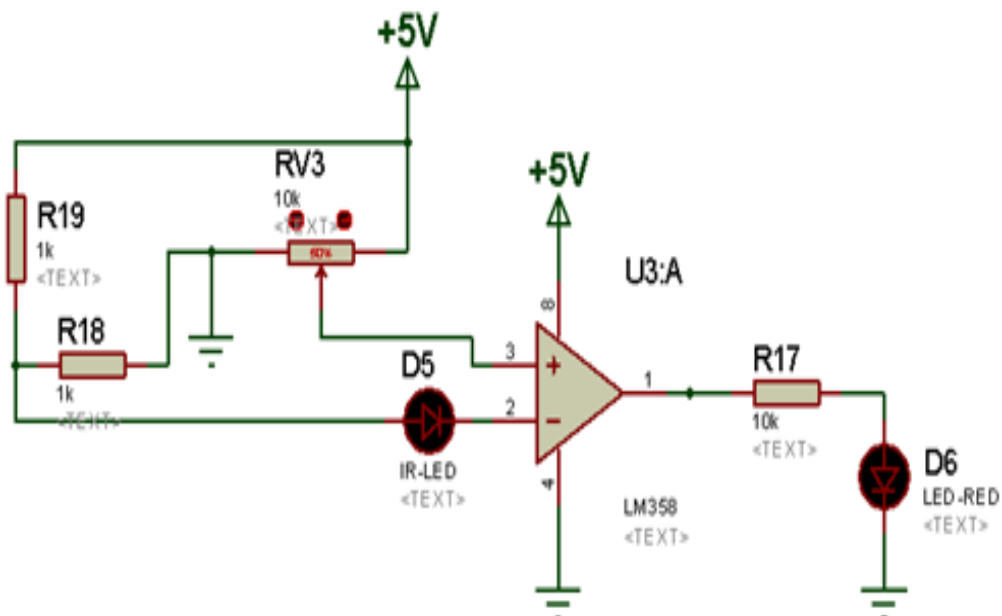

**Figure 4:** The receiver circuit of the encoder

The resistors  $R_{19}$  and  $R_{18}$  form a voltage divider to provide 2.5V to the IR LED by the voltage divider rule:

$$V_{R5} = \frac{R_{18}}{R_{18} \times R_{19}} V_{CC} \quad (1)$$

$$V_{R5} = \frac{1000}{2000} \times 5$$

$$V_{R5} = 2.5V$$

When infrared light falls on the IR LED used as a sensor, the cathode voltage drops to as low as 1.4V or more depending on the intensity of the light falling on it. The voltage drop is detected by the LM358 which compares the voltage with the 1.6V at the pin 5 generated from the 10KΩ potentiometer. The output pin 1 of the comparator goes high when the voltage at the cathode of the IR LED falls below 1.6V. So the output will be high when infrared light is detected. An LED is used to indicate a high and low signal on the output (pin 1) of the op-amp and its current is being limited by a 3.8KΩ resistor to 0.9mA as shown below:

$$I_L = \frac{V_{CC} - V_d}{R_s} \quad (2)$$

$$I_L = \frac{5 - 1.8}{3800} = 0.9 \text{ mA}$$

The voltage drop across a red LED is 1.8V.

**The Wireless Link:** The transmitter and receiver units communicate via 413MHz Radio Frequency link (See Figure 8 and Figure 9 for the complete circuit diagram for the transmitter unit and the receiver unit respectively). In the transmitter unit, the microcontroller transmits the range sensor distance and the angle via the transmitter module and the receiver unit receives this message via the receiver module. Both communicate using USART protocol so the RF modules are connected to transmit and receive data pins respectively.

A digital logic *id* inputted in the transmitter is available in the receiver but the receiver can only retain that logic for a few milliseconds after which it starts receiving random logic repeatedly (garbage info). In order to solve this problem, information is transmitted in packet size with error detection so that reliable information can be received by the receiver. The error detection packet format used in this design is stated as follows:

*Step 1:* Send a junk data (J), to stabilize the receiver

*Step 2:* Send a preceding character twice to indicate commencement of a valid data. The transmitter sends three different kinds of message to the receiver which is; object distance, object angle and range sensor status (no detection and error status). When transmitting distance, the character that precedes the distance is D; A for angle; N for no detection and E for error. When the receiver unit decodes any of these characters, it is able to know what information was sent to it.

*Step 3:* After the character, send the actual data

*Step 4:* Send inverse of actual data

*Step 5:* Send a stop data (Z) to indicate end of packet.

Both the transmitter unit and receiver unit are configured to communicate using this packet. The respective packet formats are thus;

For Object distance;

<J><D><D><distance><distance inverse><Z>

For Angle;

<J><A><A><angle><angle inverse><Z>

For Status;

<J><S><S><status><status inverse><Z>

The receiver decodes this packet using the flowchart shown in **Figure. 5**

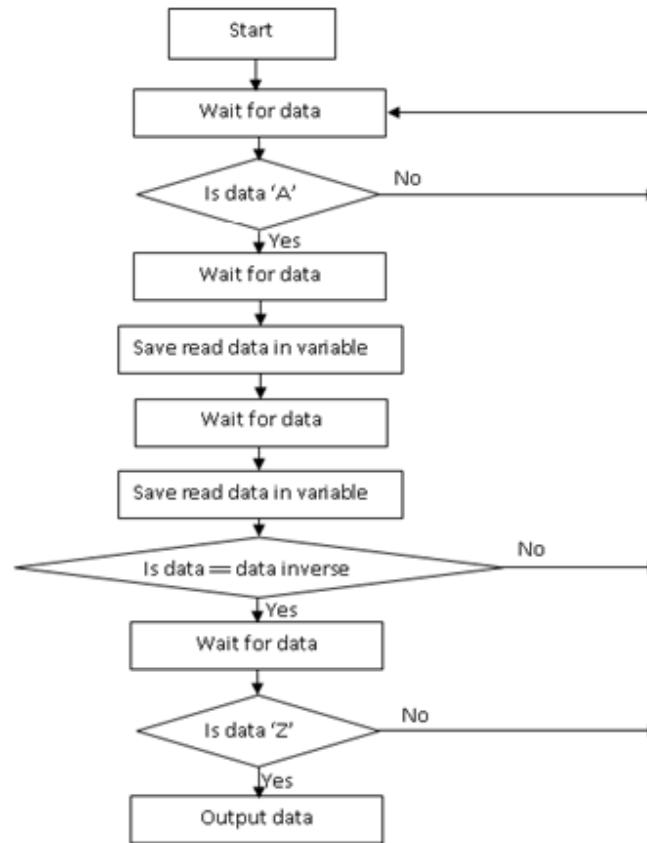

**Figure 5:** Flow Chart of Receiver Packet Decoding Process

### 3. Implementation and Testing

After the whole construction, both the transmitter and the receiver unit were tested to ensure they function as desired. Also, the complete circuits (i.e. the transmitter and receiver circuit respectively) were powered ON. An obstacle was placed within the sensor range of coverage and the display on the LCD was observed and noted as shown in Figure 6.

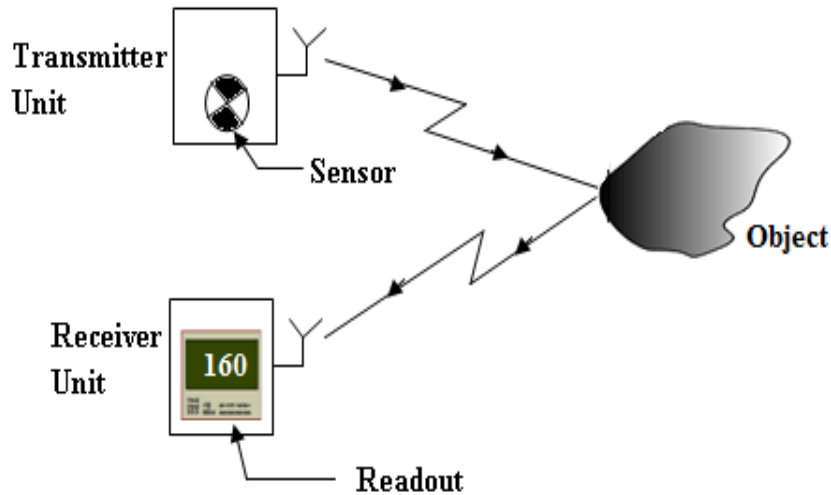

**Figure 6:** Implementation and Testing of Object Sensing and Ranging System

#### 4. Results

After the implementation of the Directional Object Sensing and Ranging System, object distance ranging between 50cm and 250cm, were measured from the system. Also, various angles were measured from the system. The displayed range and measured range are tabulated in the Table 1.

**Table 1:** Table of Readout Distance and Measured Distance Readout from the Object Sensing and Ranging System

S/N	Distance (cm)		Error (cm)
	Readout Distance	Measured Distance	
1.	250	238	12
2.	210	200	10
3.	160	153	7
4.	100	94	6
5.	50	48	2

The distance readout from the LCD is compared against the measured distance as shown in Figure 7.



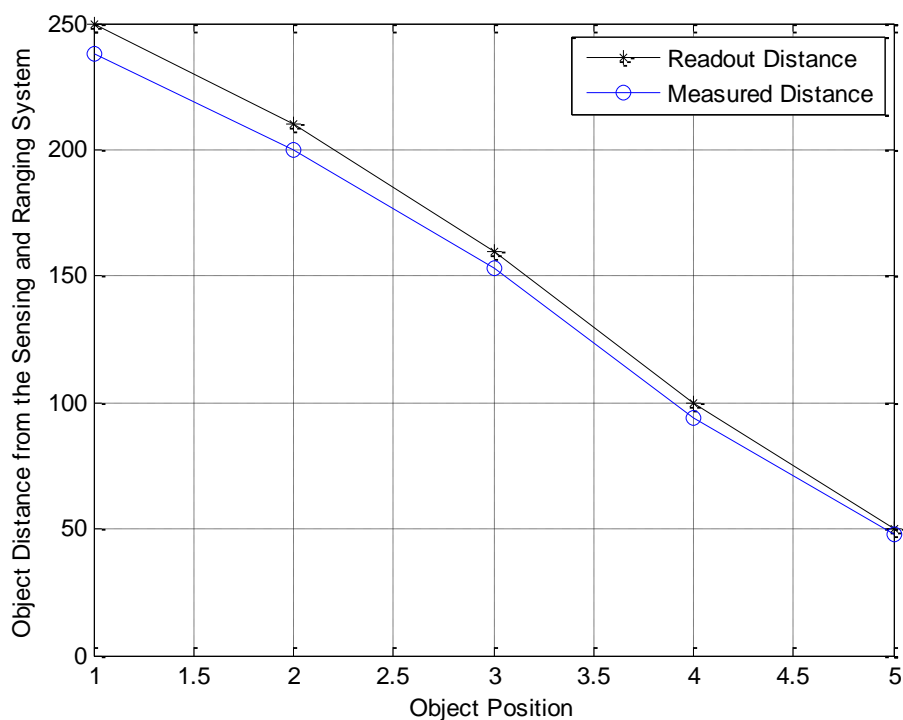

**Figure 7:** Comparison between Readout Object Distance and Measured Object Distance

## 5. Conclusion

It is seen that the ultrasonic sensor was only able to transmit a range of about 2.5m. There were slight differences between the measured distances and the readout distances from the LCD. This could be attributed to partial sound absorption by an object. The Directional Object Sensing and Ranging System in this research can help improve security and automation systems as well as improve the performance of target acquisition weaponries whose task is to neutralize any alien body in a region because it can accurately acquire (or predict in the case of moving bodies) object distances. The system can be used to secure highly valued equipment or check intrusion into a restricted facility. After the design and testing of the system, it was found that, it meets its design specification

## REFERENCES

- Skolnik, Merrill L., (2001), "Introduction to Radar Systems. 3<sup>rd</sup> ed." New York; Chikago: McGraw Hill.
- Martin Kothe, (2008) "Object Recognition with Surveillance Radar System" Diplomstudiengang Elektro- und informationstechnik University of Applied Sciences, Konstanz, Germany.
- Kostenko, A. A., Nosich, A. I. and Tishchenko, I.A (2001), "Radar Prehistory, Soviet Side: Development of the three-coordinate L-band pulse radar in Ukraine in the late 1930's", Proceedings of IEEE APS International Symposium Digest, Boston, 2001, vol.4. pg. 44-47.
- Bonnier Corporation (1935), "Popular Science". Bonnier Corporation. pg. 29-34.
- Bonnier Corporation (1941), "Popular Science", Corporation. pg. 56-70.
- Hearst Magazines (1941), "Popular Mechanics", Hearst Magazines. pg. 26-32.
- Hearst Magazines (1935), "Popular Mechanics", Hearst Magazines. pg. 844-849.
- Jones F. E. (1946), "Oboe: A precision ground-controlled blind-bombing system" , Journal of the Institution of Electrical Engineers - Part IIIA: Radiolocation **93** (2): 496. [doi:10.1049/ji-3a-1.1946.0133](https://doi.org/10.1049/ji-3a-1.1946.0133).

Wolfgang Weidmann (1999), “Radar Sensing and Detection of Moving and Stationary Objects”, Innovative Sensor Technology (InnoSenT), [www.innosent.de](http://www.innosent.de).

Aloysius Wehr, Uwe Lohr (1999), “Airborne Laser Scanning – An Introduction and Overview”, ISPRS Journal of Photogrammetry & Remote Sensing 54 (1999), pg. 68-82.

C. Vincent Tao (2001), “Database-Guided Automatic Inspection of Vertically Structured Transportation Objects from Mobile Mapping Image Sequences”, Photogrammetric Engineering & Remote Sensing Vol. 67, No. 12, December 2001, pp. 1401-1409

R. D. Lorenz et. Al (2001), “Cassini Radio Detection and Ranging (RADAR): Earth and Venus Observations”, Journal Of Geophysical Research, Vol. 106, No. A12, pg. 30271 - 30279.

Viet Thuy Vu, Thomas Sjögren, Mats Pettersson, Anders Gustavsson, and Lars Ulander (2010), “Detection of Moving Targets by Focusing in UWB SAR, Theory and Experimental Results”, IEEE Transactions on Geoscience and Remote Sensing, Vol. 48, No. 10, pp. 3799-3815, 2012.

Celestin Twizere, “Impact of Car Radar Gun on Road Traffic Safety in Rwanda”, International Journal of Emerging Technology and Advanced Engineering, Volume 3, Issue 9, September 2013.

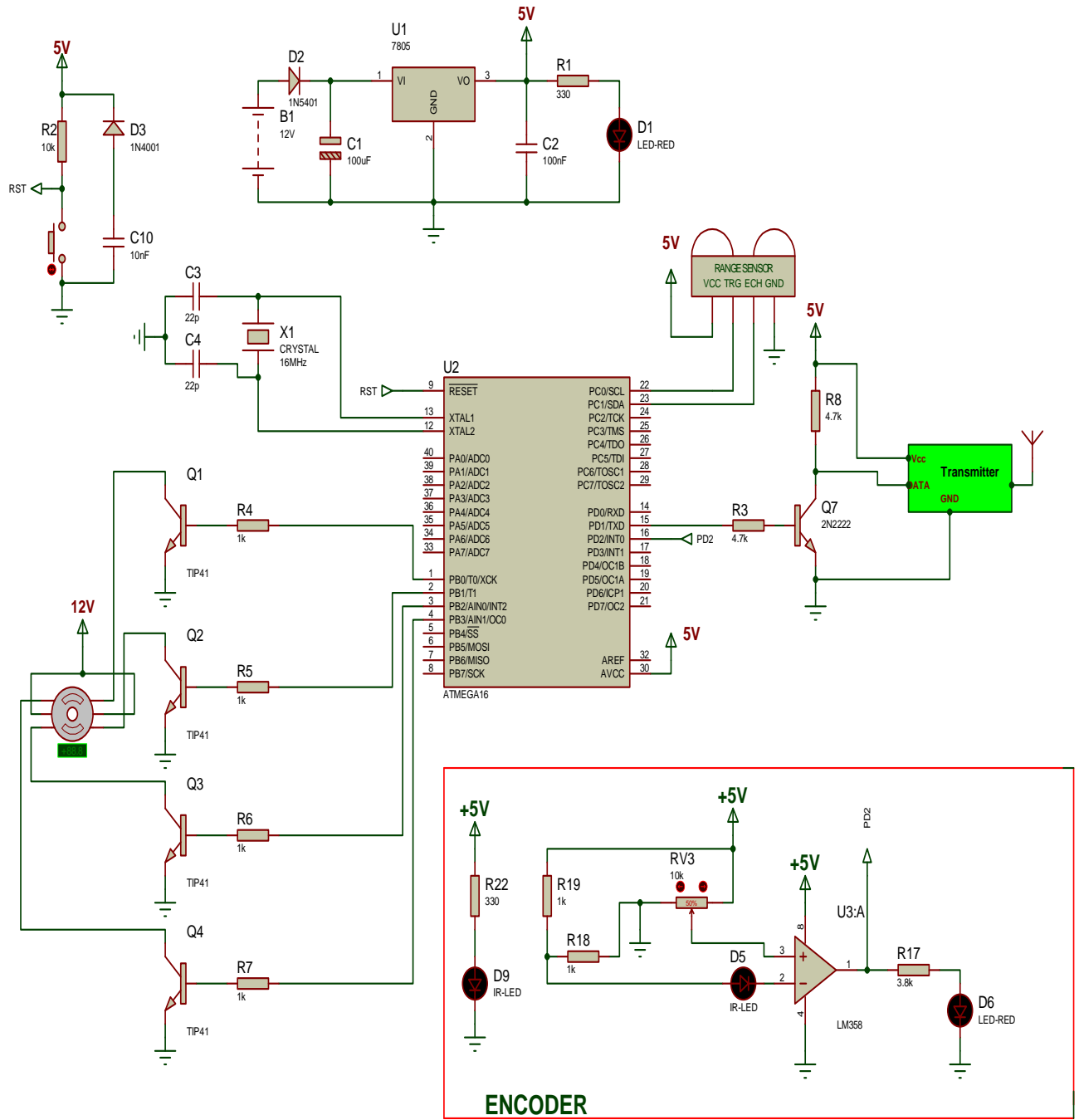

**Figure 8:** Complete Circuit Diagram of The Transmitter Unit

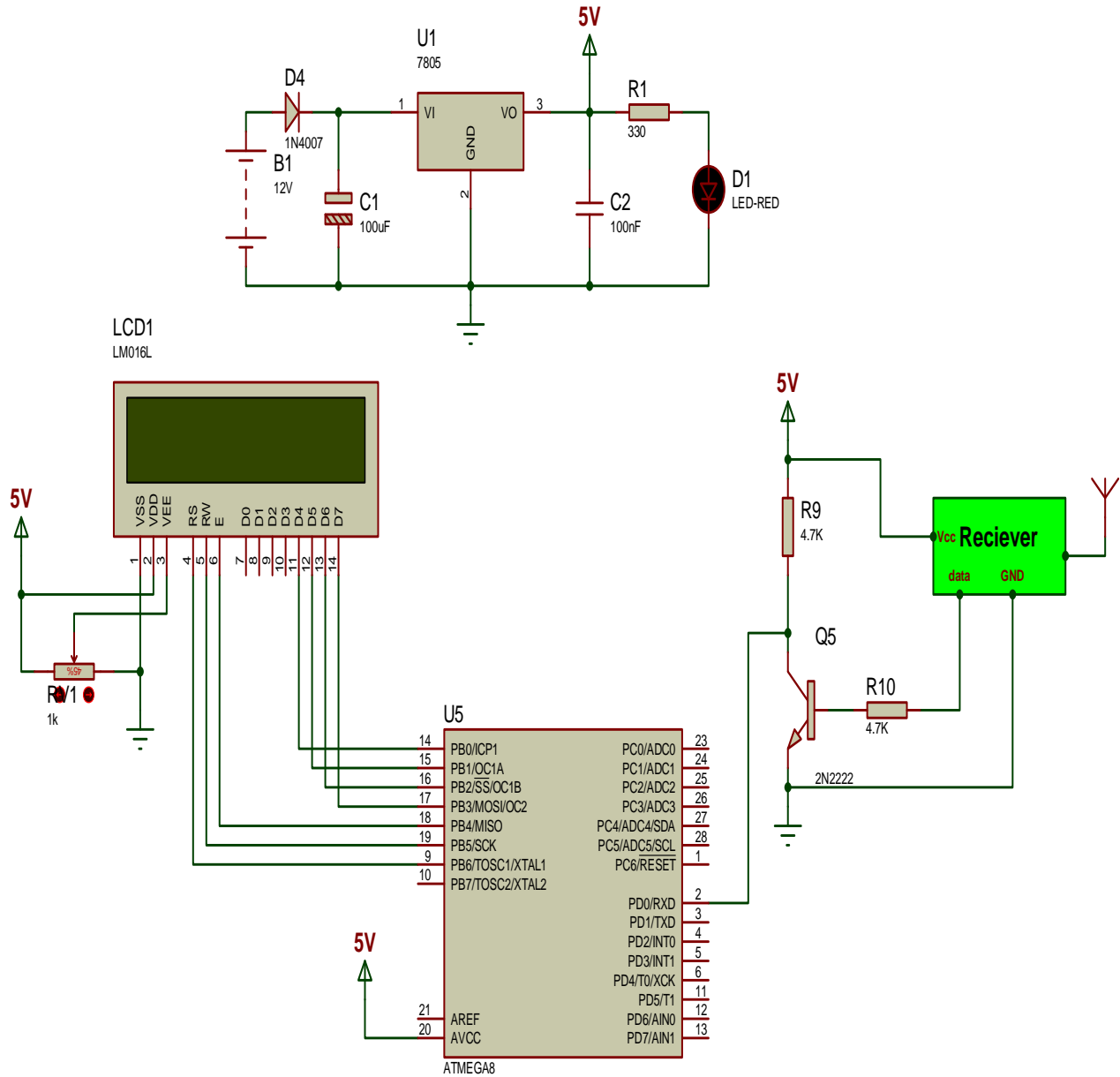

**Figure 9:** Complete Circuit Diagram of the Receiver Unit

The IISTE is a pioneer in the Open-Access hosting service and academic event management. The aim of the firm is Accelerating Global Knowledge Sharing.

More information about the firm can be found on the homepage:  
<http://www.iiste.org>

## CALL FOR JOURNAL PAPERS

There are more than 30 peer-reviewed academic journals hosted under the hosting platform.

**Prospective authors of journals can find the submission instruction on the following page:** <http://www.iiste.org/journals/> All the journals articles are available online to the readers all over the world without financial, legal, or technical barriers other than those inseparable from gaining access to the internet itself. Paper version of the journals is also available upon request of readers and authors.

## MORE RESOURCES

Book publication information: <http://www.iiste.org/book/>

## IISTE Knowledge Sharing Partners

EBSCO, Index Copernicus, Ulrich's Periodicals Directory, JournalTOCS, PKP Open Archives Harvester, Bielefeld Academic Search Engine, Elektronische Zeitschriftenbibliothek EZB, Open J-Gate, OCLC WorldCat, Universe Digital Library, NewJour, Google Scholar

