

Design of Enhanced MPPT Techniques for Solar and Wind Energy Conversion Systems in a Microgrid

L Jayasree

M.Tech, Solar Power Systems, Madanapalle Institute of Technology and Science
Madanapalle, Chithoor, A.P, India-517325

D.Chinnakullay Reddy

Assistant professor, Department of EEE, Madanapalle Institute of Technology and Science
Madanapalle, Chithoor, A.P, India - 517325

Abstract

DC Microgrid is one feasible and effective solution to integrate renewable energy sources as well as to supply electricity. This paper proposes the enhanced Maximum Power Point Tracking (MPPT) techniques for wind and solar energy systems in a microgrid. In this paper, the PV system power generation is enhanced by introducing a two-model MPPT technique that combines incremental conductance and constant voltage MPPT algorithms. Also, for the Wind Energy Conversion System (WECS) with pitch angle controlling technique, an Optimal Power Control MPPT technique is added. The Space Vector Pulse Width Modulation technique is introduced on grid side converter to improve the supply to the grid. The performance of proposed system is analyzed and the efficiency obtained with these methods is enhanced as compared with the MPPT methods that work independently.

Keywords: PV system, WECS, two-model MPPT, Optimal Power Control, SVPWM technique.

1. Introduction

The rapid depletion of conventional sources is increasing the demand for the use of renewable sources. Mainly wind and solar with their abundance and high potential gained the attention of the world. There are different concepts and technologies developed from years in order to utilize the available sources. Both wind and solar power system generations change with varying weather conditions. To best utilize the sources each are provided with some techniques. There are different MPPT techniques [1]-[5] generally being used in PV systems. The Perturb & Observe (P&O) [6]-[7], the Incremental Conductance (INC), Open Circuit Voltage, Short Circuit Current are generally used MPPT techniques and each has its own drawbacks. The P&O produce oscillations around the Maximum Power Point (MPP) even under steady state illumination. The INC method is efficient and accurate even under varying weather conditions but its controlling circuit is complex than P&O. The open circuit voltage and short circuit current method are simple but not efficient for high energy generation units.

To improve the performance of the PV system at any weather condition, the two-model MPPT technique is introduced. From the generally used techniques, any two techniques are combined based on the climatic conditions of an area and of all combinations; the Incremental Conductance and Open Circuit Voltage combination is efficient and accurate for all weather conditions[8]-[9].

The Wind Energy Conversion System (WECS) has different concepts in terms of generators, fixed and variable speed wind turbine generators. Here, it is provided with a Permanent Magnet Synchronous Generator (PMSG), a pitch angle controlled wind turbine and also with an MPPT technique that acts in accordance with the wind speed. The PMSG is a variable speed wind turbine generator which is much efficient than Doubly Fed Induction Generator of the same type. The wind and solar power that was generated is integrated at the microgrid. The dc power is boosted and then converted to ac using an inverter. To control the power at the inverter end, it is provided with Space Vector Pulse Width Modulation technique that eliminates the distortions in output voltage and improves the efficiency.

The novelty of this paper is to improve the power generation of both the PV system and WECS with enhanced techniques. The contributions of the paper include (1) Analysis of different MPPT techniques for a PV system and to design a two-model MPPT technique. (2) Development of a WECS with PMSG [10]-[12] and deploying the pitch angle controlling technique and an Optimal Power Controlling MPPT technique. (3) Integrating the PV system with WECS and implementing SVPWM technique [13]-[15] on the inverter side in order to improve the performance of output power.

The paper is organized in such a way that section 2 discusses the design of the PV system, different MPPT methods used in the PV system and the design of two-model MPPT technique. Section 3 contains the modeling of WECS with pitch angle controlling technique and optimal power controlling MPPT technique. In section 4, the integration of PV system with WECS and the SVPWM technique are discussed. The simulation results are shown and discussed in section 5. Section 6 is the conclusion of the paper.

2. Different MPPT methods for PV system

The PV module is first modeled in Mat lab based on the following equations.

$$I = I_{PV}N_{PP} - I_0N_{PP} \left[e^{\left(\frac{V+IR_S \left(\frac{N_{SS}}{N_{PP}} \right)}{V_{ta}} \right) - 1} \right] - \left[\frac{V+IR_S \left(\frac{N_{SS}}{N_{PP}} \right)}{R_p \left(\frac{N_{SS}}{N_{PP}} \right)} \right] \quad \dots (1)$$

$$I_{PV} = (I_{PVn} + k_i \Delta T) \frac{G}{G_n} \quad \dots (2)$$

$$I_0 = \left[\frac{I_{PVn} + k_i \Delta T}{e^{\left[\frac{(V_{OCn} + k_v \Delta T)}{V_{ta}} \right]}} \right] \quad \dots (3)$$

$$V_{ta} = \frac{q}{aKN_S T} \quad \dots (4)$$

Where,

I= terminal current of the PV array

I_{pv} = current of PV Cell

I₀= reverse saturation current of cell

R_s = resistance in series

R_p = resistance in parallel

V_{ta} = thermal voltage of cell

a= ideality factor

N_{pp}= modules in parallel

N_{ss}= modules in series

N_s=cells series in a module

Table 1. Reference values for the designed PV System

G=G _n =1000	N _s =54	N _p =2	K _i =0.0032	R _p =415.4	I _{scn} =8.214
T=T _n =298.15	N _{ss} =15	I _{pvn} =7.61	K _v =-0.123	R _s =0.23	V _{ocn} =32.9

With change of irradiation and other specifications of the module, the output varies. With the specifications stated above, the maximum output from the PV system is about 3W. To maintain the system at its maximum production, the Maximum Power Point Tracking (MPPT) techniques are introduced. The most generally used MPPT techniques are as follows.

2.1 Perturb & Observe (P&O) MPPT Method

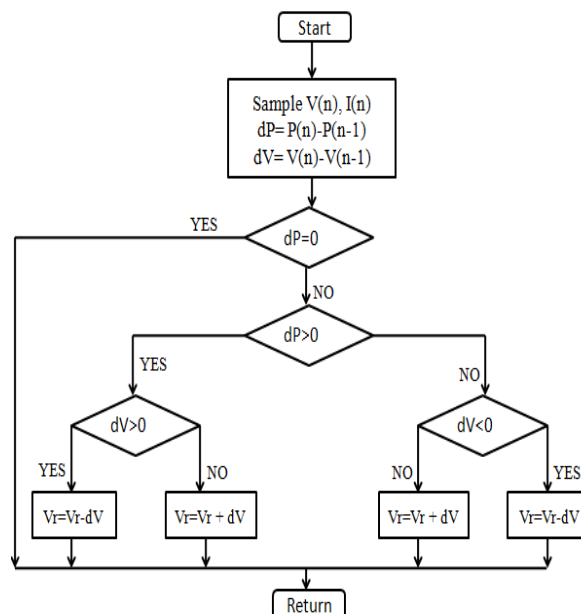

Figure1. Flowchart of P&O MPPT algorithm

The P&O MPPT algorithm is a hill climbing technique in which, the operating voltage of the PV system is perturbed by a little increase of dV , and this results change in dP . If dP is positive, the perturbation of the operating voltage should be in the same direction of the increment. On the opposing, if dP is negative, the operating point moves away from the MPPT and the operating voltage moves in the opposite direction of the increment. Figure 1 shows the flowchart of this MPPT algorithm. The disadvantage of this method is that the array terminal

voltage is perturbed for every MPPT cycle, resulting in a power loss in the PV system due to heavy oscillations of output voltage at the MPP. Furthermore, it sometimes fails to find the MPP.

2.2 Incremental Conductance MPPT Method

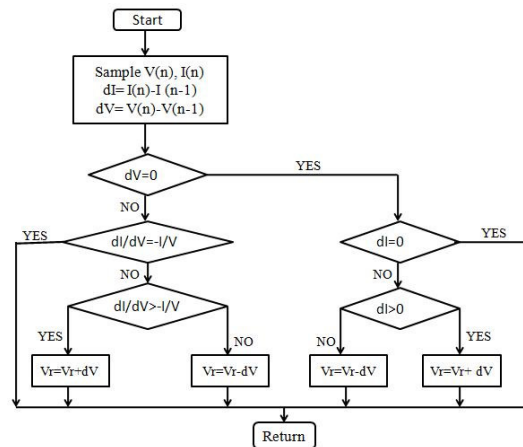

Figure2. Flowchart of INC MPPT algorithm

The PV array terminal voltage is adjusted relative to the MPP voltage with the incremental conductance (I/V) and instantaneous conductance (dI/dV) measurement. Once the MPP is reached, the function of the PV array is fixed at this point unless a change in dI is noted. If $dP/dV > 0$, the voltage is increased and in case of $dP/dV < 0$, the voltage is decreased to track the MPP as shown in figure 2. The advantages of the INC algorithm are the fine control of the system and its high stability with rapid change of atmospheric conditions.

2.3 Open Circuit Voltage MPPT Method

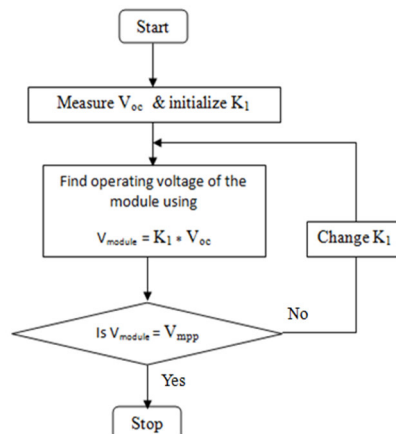

Figure3. Flowchart of OCV MPPT algorithm

The open circuit voltage algorithm is a simple MPPT technique and its flowchart is as shown in figure 3. This technique is also known as constant voltage method. V_{OC} is the open circuit voltage of the PV panel that depends on the property of the solar cells. A commonly used V_{MPP}/V_{oc} value is 76%.

This relationship can be described by equation:

$$V_{(MPP)} = k_1 * V_{oc}$$

Here the factor k_1 is always less than unity. It looks very simple but determining best value of k is very difficult and k_1 varies from 0.71 to 0.8. The common value used is 0.76; hence this algorithm is also called as 76% algorithm.

2.4 Short Circuit Current MPPT Method

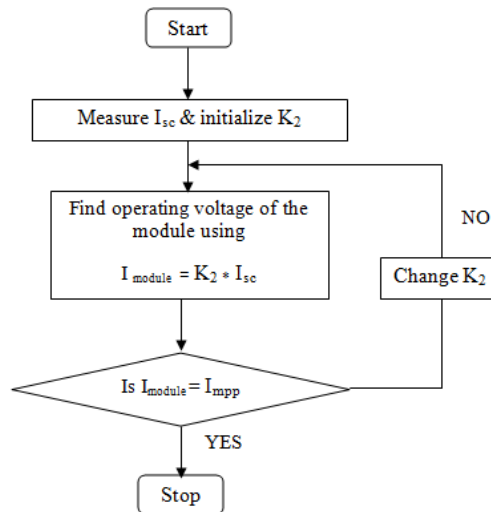

Figure4. Flowchart of SCC MPPT algorithm

This technique is also known as constant current method. I_{SC} is the Short circuit current of the PV panel. I_{SC} depends on the property of the solar cells. This relationship can be described by equation.

$$I_{(MPP)} = k_2 * I$$

Here the factor k_2 is always <1 . It looks very simple but determining best value of k_2 is very difficult and k_2 varies from between 0.78 and 0.92. When the PV array output current is approximately 90% of the short circuit current, solar module operates at its MPP as shown in figure 4.

2.5 Two-Model MPPT Method:

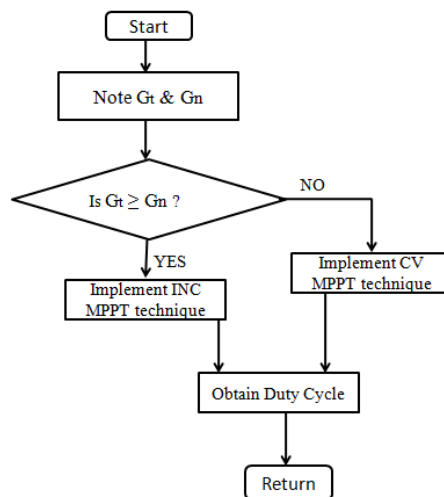

Figure5. Flowchart of two-model MPPT technique

The two-model MPPT can be designed with different techniques that are available. But, the most beneficial and efficient for the rapid changes is the combination of incremental conductance and Open Circuit Voltage model. The flowchart of proposed model is shown in figure 5 and figure 6 shows its matlab model.

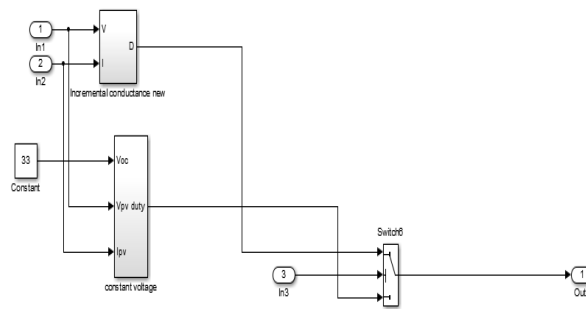

Figure6. Simulink model of two-model MPPT technique

It is important to observe that when the PV panel is in low insolation conditions, the Open Circuit Voltage technique is more effective. Here G_t is the threshold value of irradiation value and G_n is the irradiance value at particular value.

3 Wind Energy Conversion System

The wind energy is the one which is much available after solar energy and is a promising source of electrical energy. The kinetic energy of the wind is used to rotate the turbines that generate mechanical energy. The generators convert the mechanical energy to electrical energy.

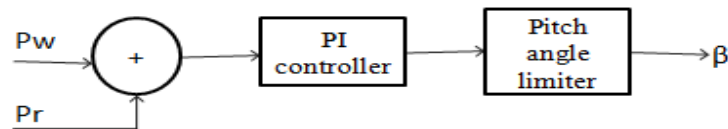

Figure7. Pitch angle controller

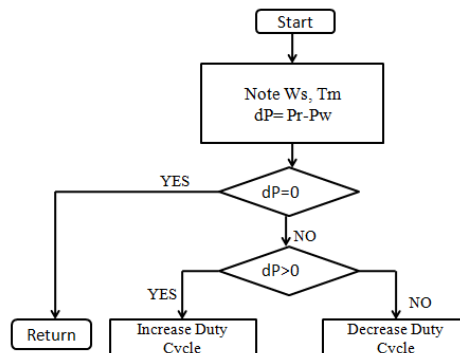

Figure8. MPPT algorithm for WECS

4 Integration of PV system to WECS

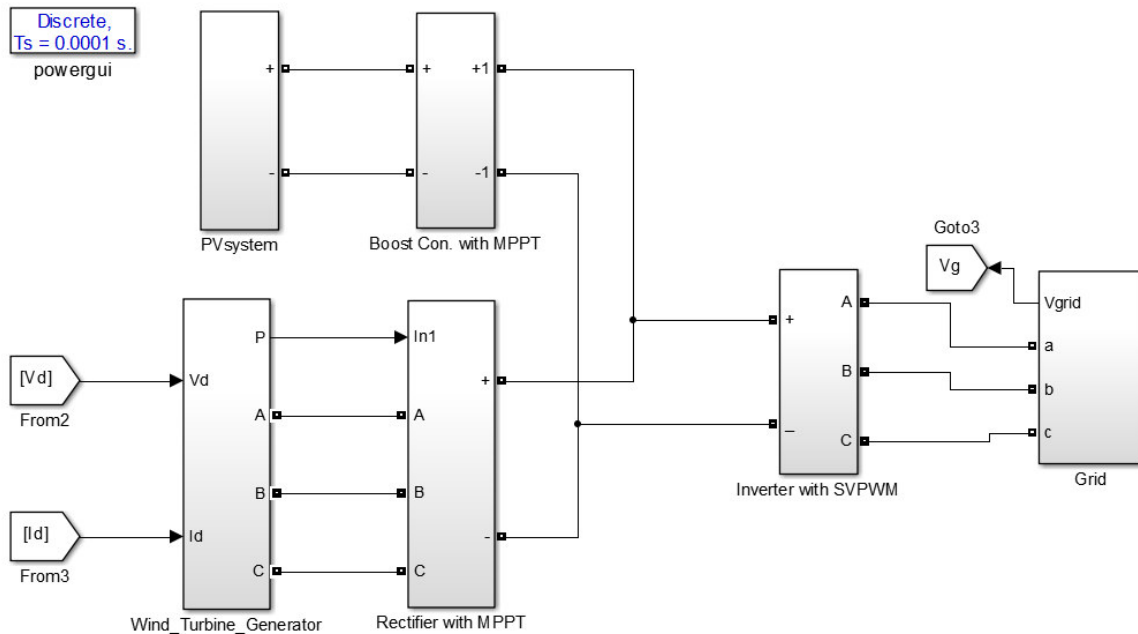

Figure9. Simulink block diagram integration of PV system & WECS

The PV system and the WECS are integrated at a point and it is supplied to an inverter to generate AC output. On the inverter side, SVPWM technique is provided to improve the quality of the power. Figure 9 shows the simulink block diagram of the proposed microgrid.

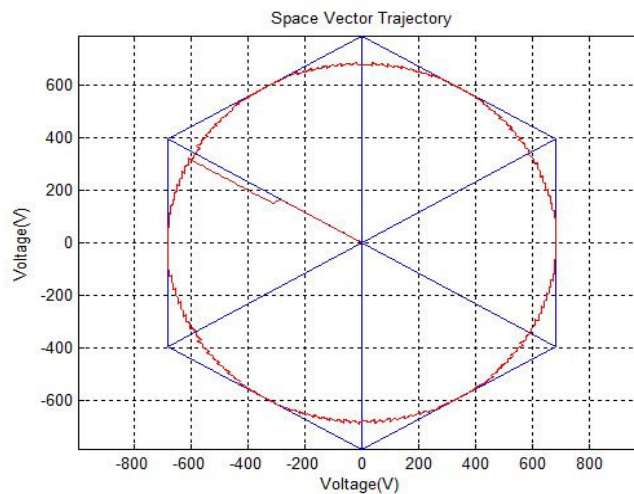

Figure10. Space vector trajectory

The Space Vector Pulse Width Modulation Technique is an advanced computation-intensive PWM method and is possibly the best of all the PWM techniques for variable frequency drive applications. It improves the quality of the generated output. One important advantage of this technique is it reduces the Total Harmonic Distortion(THD) created by the rapid switching.

5 Results

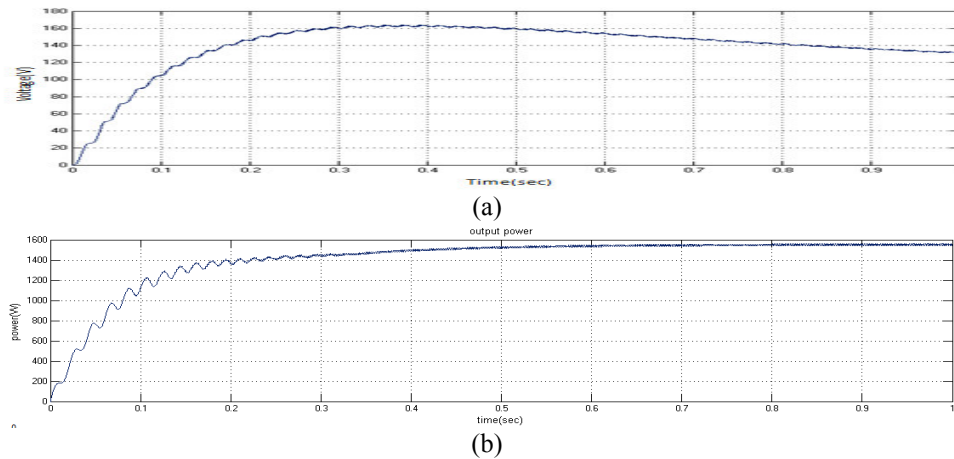

Figure 11. PV system at irradiation of $1000\text{W}/\text{m}^2$ (a) Voltage (b) Power

The output voltage and power of a PV system at irradiation of $1000\text{W}/\text{m}^2$ without any MPPT techniques is shown in figure 11.

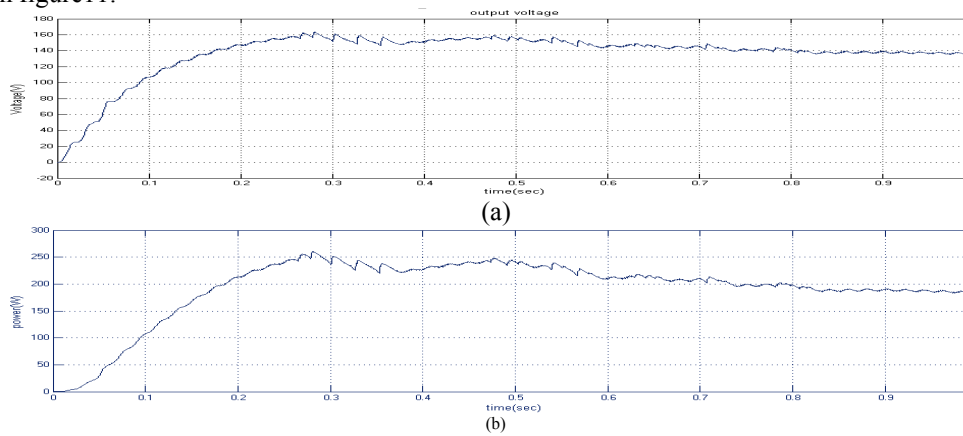

Figure 12. PV system with Constant Voltage MPPT technique (a) Voltage (b) Power

The voltage and power waveforms of a PV system at irradiation of $1000\text{W}/\text{m}^2$ with Constant Voltage MPPT technique are shown in figure 12.

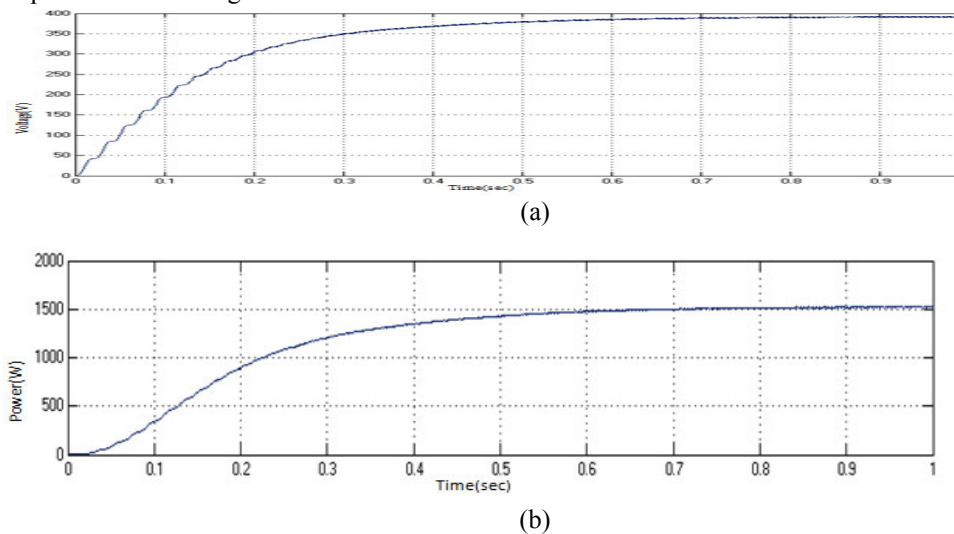

Figure 13. PV system with INC MPPT technique (a) Voltage (b) Power

Using the Incremental Conductance MPPT Algorithm, the output voltage and power of a PV system at an irradiation of $1000\text{W}/\text{m}^2$ are as shown in figure 13.

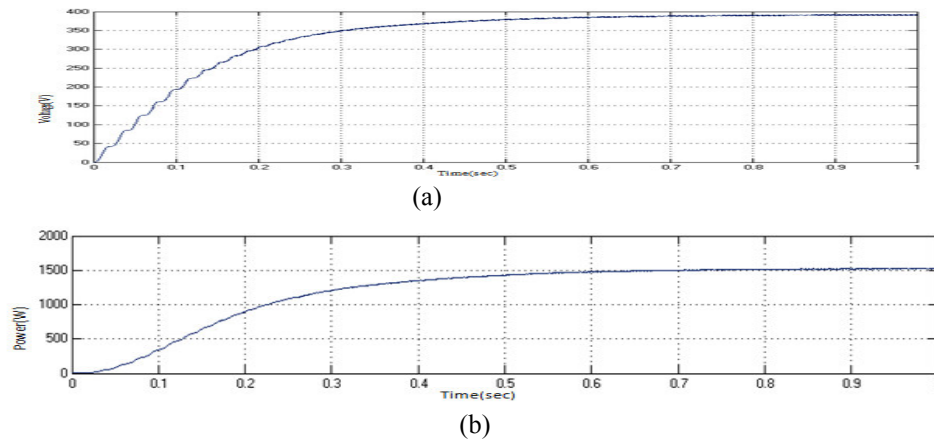

Figure14. PV system with two-model MPPT technique at 1000W/m²irradiation (a) Voltage (b) Power
 The output voltage and power of a PV system using two-model MPPT method are shown. At an irradiation of 100W/m², the voltage and power of a PV system are as shown in figure14.

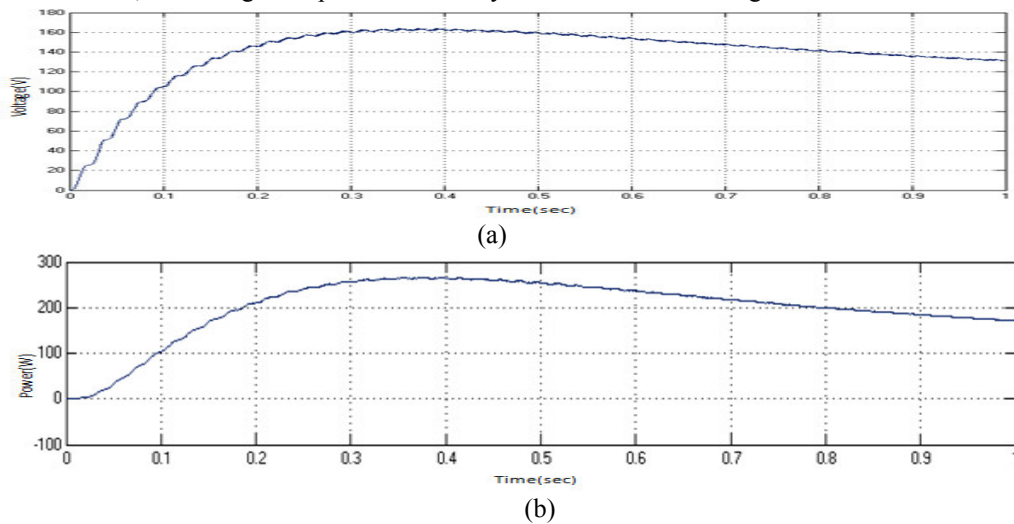
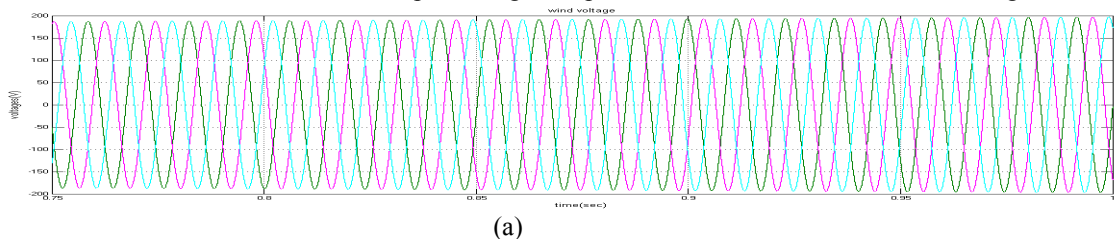

Figure15. PV system with two-model MPPT technique at 600W/m²irradiation (a) Voltage (b) Power
 For an irradiation of 600W/m², the output voltage and power characteristics are as shown in figure15.



The Wind Energy Conversion System with PMSG at a wind speed of 12m/sec and pitch angle of 0° produces voltage of 200V as shown in the figure16(a).

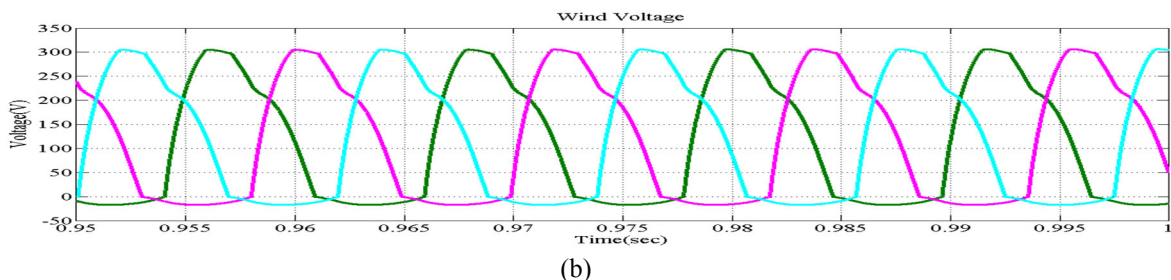

Figure16. Voltage of a WECS (a) Without MPPT technique (b) With MPPT technique
 The Wind Energy Conversion System with PMSG at a wind speed of 12m/sec and pitch angle of 0° produces with the addition of MPPT technique produces a voltage of about of 350V as shown in figure16(b).

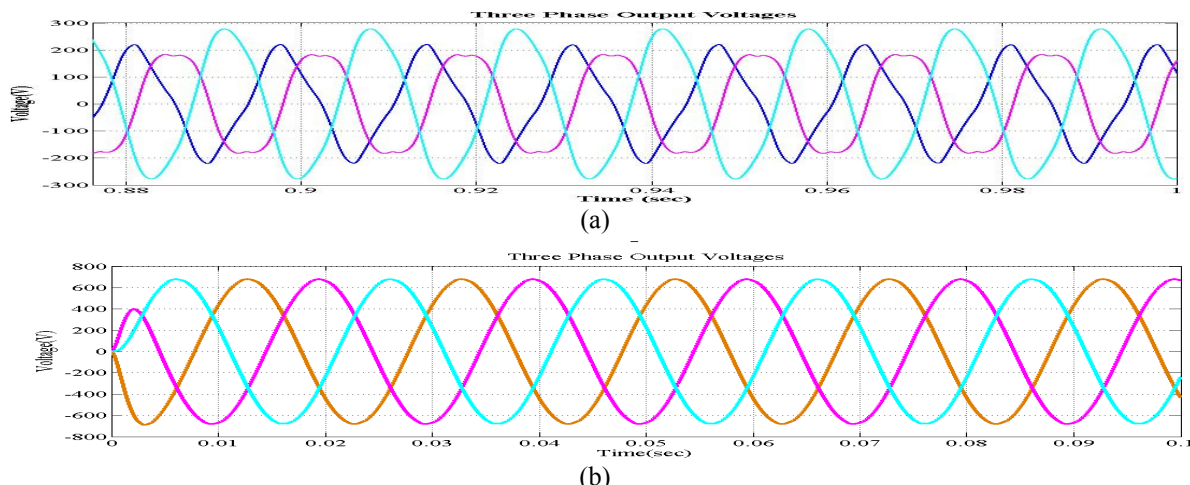

Figure 17. Output voltage of the integrated systems (a) in normal (b) with enhanced MPPT techniques

The output voltages of the solar and wind integrated system with and without the enhanced MPPT techniques as well as SVPWM technique are shown in figure 17.

Table 2. PV system results

S. No	MPPT Method	Voltage(V)
1.	Perturb & Observe	320
2.	Incremental Conductance	350
3.	Constant Voltage	150
4.	Short Circuit	120
5.	Two-Model	380

Table 3. WECS results

S. No	WECS	Voltage(V)
1.	Without MPPT	180
2.	With MPPT	300

Table 4. Integrated system results

S. No	Integrated systems	Voltage(V)
1.	With no added techniques	300
2.	With improved techniques	650

6 Conclusion

This paper thus discussed a microgrid with an improved output from both PV system and WECS. The PV system output is improved with the Two-Model MPPT than the generally used P&O MPPT model and the WECS output also enhanced with a pitch angle controlled wind turbine model and an MPPT technique. The pitch angle control technique is actuated for high wind speeds and the MPPT algorithm is for driving the rectifier to track maximum power point. Also, the quality of AC output of the microgrid is much improved with the introduction of SVPWM technique on the inverter side. The improvement is well observed through the simulink results.

References

- [1] T.Esram and P.L.Chapman, "Comparison of photovoltaic array maximum power point tracking techniques," IEEE Trans. Energy Converse., vol.22, no.2, pp.439-449, June 2007.
- [2] Roberto Faranda, Sonia Leva, "Energy Comparison of MPPT techniques for PV Systems", WSEAS transactions on Power Systems, Issue 6, Volume 3, 2008.
- [3] F.Liu, S.Duan, B.Liu, and Y.Kang, "A variable step size INC MPPT method for PV systems", IEEE Trans. Ind. Electron., vol.55, no.7, pp.2622-2628, July 2008.
- [4] T.T.N.Khatib, A.Mohamed, N.Amin, and K.Sopian, "An efficient maximum power point tracking controller for photovoltaic systems using new boost converter design and improved control algorithm", WSEAS Trans. Power Syst., vol.5, no.2, pp.53-63, 2010.
- [5] J.M.Enrique, J.M.Andujar, and M.A.Bohorquez, "A reliable, fast, and low cost maximum power point tracker for photovoltaic applications". Solar Energy, vol.84, no.1, pp.79-89, 2010.
- [6] Mohammed A.Elgeddy, Bashar Zahawi, Senior Member, IEEE, and David J.Atkinson, "Assessment of Perturb and Observe MPPT Algorithm Implementation Techniques for PV Pumping Applications", IEEE

- Transactions on Sustainable Energies, VOL.3, NO.1, January 2012
- [7] K.L.Lian, Member, IEEE, J.H.Jhang, and I.S.Tian “A Maximum Power Point Tracking Method Based on Perturb-and-Observe Combined With Particle Swarm Optimization”, IEEE Journal of Photovoltaics, VOL.4, NO.2, March 2014
 - [8] M.Calavia1, J.M.Perié1, J.F.Sanz, and J.Sallán, “Comparison of MPPT strategies for solar modules” in Proc. Int. Conf. Renewable Energies Power Quality, Granada, Spain, March 2010.
 - [9] Bidyadhar Subudhi, Senior Member, IEEE, and Raseswari Pradhan, “A Comparative Study on Maximum Power Point Tracking Techniques for Photovoltaic Power Systems”, IEEE Transactions on Sustainable Energies, VOL.4, NO.1, January 2013
 - [10] E.Denny and M.O'Malley, "Wind generation, power system operation, and emissions reduction," Power Systems, IEEE Transactions, vol.21, pp. 341-347, 2006.
 - [11] K.Tan, S.Islam, “Optimum control strategies in energy conversion of PMSG wind turbine system without mechanical sensors”, IEEE Transactions on Energy Conversion, vol.19, pp.392-99, June 2004.
 - [12] M.Chinchilla, S.Arnaltes and J.C.Burgos, “Control of permanent magnet generators applied to variable-speed wind-energy systems connected to the grid”, IEEE Transactions on Energy Conversion, Vol.21, No.1, pp.130-135, March 2006.
 - [13] Joachim Holtz, “Pulse width modulation - A survey”, IEEE Trans. Ind. Electron., vol.39, no.5, pp.410-420, Dec 1992.
 - [14] Abdul Rahiman Beig, G.Narayana, V.T.Ranganathan, “Modified SVPWM Algorithm for Three Level VSI with Synchronized and Symmetrical Waveforms”, IEEE Trans. Ind. Elect., Vol.54, No.1, pp 486-494, Feb.2007.
 - [15] S.Das and G.Narayanan, “Novel switching sequences for a space-vector modulated three-level inverter”, IEEE Trans.Ind. Electron., vol.59, no.3, pp.1477-1487, March 2012.