

Implementation of Just in Time Production through Kanban System

Ahmad Naufal Bin Adnan (Corresponding author)

Faculty of Mechanical Engineering, Universiti Teknologi Mara, 40450 Shah Alam, Selangor, Malaysia.
Tel: 03-55435278 Email:ahmadnaufaladnan@yahoo.com

Ahmed Bin Jaffar

Faculty of Mechanical Engineering, Universiti Teknologi Mara, 40450 Shah Alam, Selangor, Malaysia.
Tel: 03-55435159 Email:ahmedjaffar@salam.uitm.edu.my

Noriah Binti Yusoff

Faculty of Mechanical Engineering, Universiti Teknologi Mara, 40450 Shah Alam, Selangor, Malaysia.
Tel: 03-55211821 Email:noriahyusoff@salam.uitm.edu.my

Nurul Hayati Binti Abdul Halim

Faculty of Mechanical Engineering, Universiti Teknologi Mara, 40450 Shah Alam, Selangor, Malaysia.
Tel: 03-55211821 Email:hayatihalim@salam.uitm.edu.my

The research is financed by Research Management Institute, Universiti Teknologi MARA.

Abstract

Uncertainties brought about by fluctuations in demand and customers' requirements have led many established companies to improve their manufacturing process by adopting the Kanban system. By doing so, they are able to manufacture and supply the right product, in the right quantity, at the right place and time. Implementation of the Kanban system resulted in reduction of inventory to minimum levels besides increasing flexibility of manufacturing. Successful implementation of the Kanban system furthermore reduces operational costs, consequently increases market competitiveness. The Kanban system is basically an inventory stock control system that triggers production signals for product based on actual customers' requirements and demand. The system is controlled by the Kanban card which dictates the optimum production parameters. It is used to authorize production of any product to replenish those already consumed by the customer or subsequent process. This study covers pre-requisite activities in establishing a Kanban system, starting from designing Kanban flow, gathering manufacturing data, calculating optimum Kanbans in the systems, establishing pull mechanism and rule and finally evaluating Kanban performance using lean parameter. This paper studied the implementation of the Kanban system at a local auto-component company in Malaysia. The scope of implementation was focused at BLM Cylinder Head Cover assembly process. This paper concludes that implementation of the Kanban system reduced lead time, minimized inventory on floor and optimized storage area. The objective of this study is to show that Kanban system improves a manufacturing system as well as achieving Just In Time practice.

Keywords: Just In Time, Kanban system, Manufacturing lead time reduction

1. Introduction

Traditional manufacturing strategy is driven by 'Push system' with aimed to have huge inventory of product for customer's needs. Planning schedule that used as production authorization mechanism has push material from one location to other location. However, this created big problem for people on the floor in dealing with huge WIP inventories, unsynchronized production processes and producing non-required products.

As a result, established companies like Toyota Motor Corporation moved to the next level of manufacturing strategy by adopting the Kanban system [1]. The adoption of Kanban system has improved their efficiency and flexibility of manufacturing according to customer needs. The Kanban system is a pull system approach that gives authorization to produce at a required rate and specific time in order to replenish part that already consumed by the customer [2, 7].

As one of the lean manufacturing principles, Kanban system emphasized minimum level of inventory by producing only what is needed. It ensures the supply of the right product, at the right time, in the right quantity and at the right place. Kanban system becomes practical; it synchronizes all manufacturing activities entire manufacturing with customer demand [5]. Every process on the floor is controlled by Kanban system which is designed to respond to actual demands.

Nowadays, many companies has faced customer pressure to produce products with high value, to deliver quality product at a competitive price. They have to focus to meet these needs as a requirement to remain and stay successful in today's market [5]. The process of producing product is more efficient and effective when Kanban system is implemented [2]. A comparative study was made between push and pull systems in order to justify the benefits of Kanban system. Push system that holds huge inventory tend to have higher cost of operating than pull

system. However it required additional investment to change current system to pull system [6]. Therefore, support and commitment from management is crucial to achieve the goal.

To achieve world class manufacturing level, many companies have moved toward becoming lean by adapting Just in time (JIT) practice in their manufacturing system. The Kanban pull system under JIT approach offer great benefits. The purpose of this system is to link manufacturing activities to market demand. Many research carried out has shown that maximum benefits can be gained in manufacturing areas such as reduction of inventory, reduction in lead time, improvement of value added time, increased productivity of process and also improving product quality [8].

In Malaysia, the implementation of lean manufacturing had started in mid 1980s through the introduction of the Look East Policy by the government [4]. Implementation then had focused on quality and efficiency improvements. Furthermore, this policy provided valuable knowledge to practitioners in identifying customer value and eliminating waste in order to deliver superior products at less cost.

Due to stiff competition in the automotive and manufacturing sectors, the awareness of lean manufacturing had increased among local players because one of the ways to stay competitive and become a champion in industry is by adopting lean methodologies and principles in all aspects of manufacturing processes.

This research paper discusses the implementation of the Kanban pull system to a high volume medium variety of manufacturing line at a local auto-component company in Malaysia. A cylinder head cover manufacturing process was selected for study. This research focuses on activities from assembly production line to warehouse. The objective of this paper is to demonstrate the various gains achieved when the Kanban system is used in manufacturing area. Hence paper presents a case study research which features the actual Kanban implementation at the Cylinder head cover assembly line until the finished good warehouse. Methods of kanban implementation are highlighted.

2. Literature review

The 'Just in time' (JIT) approach is based on a lean manufacturing system which was developed to optimize and improve manufacturing efficiency by reducing manufacturing lead time through waste elimination. It was derived from the Toyota Production System as a purpose to minimize inventory and improve throughput [9].

It has been described as an approach to produce the right part and quantity when it is needed either by end customer or next process [2, 4]. Takt time which derived from demand is used to regulate manufacturing pace on floor [10]. As a result, smoothed material flow and synchronized processing time has been established to increase efficiency and productivity of the manufacturing system. JIT implementation would expose all wastes at the entire area that are currently hidden when inventory is reduced.

Levitt and Abraham [11] conclude that implementation of JIT in semiconductor manufacturing has lead to reduction of manufacturing time and excellent regulating of manufacturing method with different bottleneck time. However, Stump and Badurdeen [9] had argued that JIT is applicable for industries with less customization module and high standardization. Only a few ideas are practical to apply in mass customization and low standardization area for example kaizen and visual housekeeping management (5S).

Pull system is used to manage inventory and control flow of material. It is driven from downstream needs which trigger upstream production. At the manufacturing area, the pull system would be able to reduce inventory level by replenishing parts that are consumed by the customer. The authorization of production begins when a part is pulled from the inventory area [1, 2]. Kanban means card in Japanese; this card contains all the required information for this system [2]. The Kanban system serve as a tool to regulate pattern of material flow that effectively links upstream operations to downstream operations.

Several research were made about the Kanban system. Sendir Kumar and Panneerselvam [4] in their literature review had described that a few methods was found out such as Kanban, Conwip and supply chain management in order to achieve JIT goals. Other than that, the Kanban pull system is widely implemented in repetitive manufacturing environments that focus to minimize work in progress inventory, increase throughput and improve production efficiency. Card attached to part is removed when demand from downstream occurs. Then this card would be returned to trigger production at upstream. Therefore, the Kanban system aid to reduce inventory by producing just in time to meet demand at each production stage [2, 4].

N. Singh and Kwok Hung Shek[2] studied how to develop the Kanban system at an assembly area using General Purpose Simulation System. In order to achieve lean goal, essentially kanban system is established on factory floor to align flow of material by removing all waste and sources of waste. Waste is anything that customer is not willing to pay for and it could be categorizes into 7; transportation, over inventory, excess of motion, waiting, over process, over production and defect [4, 5, 8].

There are two types of the Kanban systems, the single card Kanban system and two card Kanban system [4]. Single card Kanban system uses only 1 type of Kanban card to trigger upstream production when it needed. This card is called the Production Instruction Kanban (PIK). The two card Kanban systems uses two types of card

which are Production Withdrawal Kanban (PWK) and Production Instruction Kanban (PIK). PWK card is used to withdraw needed goods from preceding process and PIK card is used to give instruction to preceding process to produce what is needed for replenishment purpose.

A Kanban system implemented at a manufacturing area is equipped with relevant tools. These tools are used to smooth the system, visualize current operation and assist production associate to work according to takt time. Heijunka board, lot formation post, kanban post and kanban card are tools used in establishing kanban pull system.

3. Methodology

In this section, the method to develop kanban system is presented. Then evaluation of performance was carried out once the Kanban system was adopted in manufacturing area. The adoption of continuous flow system is essential prior to any kanban system implementation. In fact, Siemens Standard Drive's Congleton factory was initially implemented continuous flow system in order to reduce stability issue before kanban system was adopted [3]. Hence, the production line has adopted continuous flow system, which mean, wastes were eliminated and line was working according to takt time.

To achieve the objective of case study, the method was structured as follow;

- i. Designing kanban flow
- ii. Gathering relevant parameter of manufacturing and customer
- iii. Calculating number of kanbans to determine optimum level of inventory
- iv. Establishing pull mechanism and rule to assist production associate in daily operation
- v. Evaluating kanban using lean parameter

The first stage is designing kanban flow based on company operation. A few criteria had been considered during kanban flow. Then gathering of relevant parameter from production floor was carried out at site. Identifying appropriate parameters were crucial for this study to achieve the objective. The observation was conducted starting from delivery area and walked throughout the manufacturing flow. This to ensure that manufacturing data are accurate and reliable for this study.

Next is calculating optimum number of Kanbans in the system. The method of calculation was based on Toyota formula. However, the model has been customized to suit with subject company. For this case, subject company has made some decision to implement two card system at final assembly line and single card system at vibration welding. Two card system is using PIK and PWK card while single card system is using PIK card only.

First, batch factor or known as Part interval [15] was defined to determined optimum batch of production for each part. Second was determination of takt time that used to synchronize manufacturing process and actual demand.

The Kanban numbers were then determining using two equations which are Production Instruction Kanban (PIK) and Production Withdrawal Kanban (PWK). The model of calculation is as follows;

$$\text{Part interval} = \frac{\text{Numbers of part variant}}{\text{Possible numbers of change over}} \quad (1)$$

$$\text{Part takt time} = \frac{\text{Available time}}{\text{Part demand}} \quad (2)$$

$$PIK = ((W_K + T_L)/T_T + \alpha)/c + T_w \quad (3)$$

where, kanban variables area:

W_K = withdrawal time,

T_L = time to replenish part

T_T = part takt time,

T_w = time for waiting kanban,

α = safety stock

c = container capacity

$$T_L = \text{Setup time} + \text{Processing time} + \text{Waiting 1 container complete} \quad (4)$$

$$W_p = \left(\frac{\text{Part interval} \times \text{Part demand}}{c} \right) \times 2 \times \frac{\text{Part demand}}{\text{Total demand}} \quad (5)$$

$$T_w = \left(\frac{\text{Part interval} \times \text{Part demand}}{c} \right) - 1 + W_p \quad (6)$$

$$PWK = (D + K_w + \alpha)/c \quad (7)$$

where,

D = customer demand,

K_w = quantity of kanban waiting

α = safety stock

c = container capacity

Once number of kanban is defined, the fabrication of pull mechanism was initiated. It started with preparation of kanban card, in which, must contain the required information with regard to kanban system. Second was establishing leveling or Heijunka method to regulate variety of part and volume throughout production time [10, 12, 17]. This task consists of designing and fabricating Heijunka post and kanban post. The Kanban chute was then fabricated prior to establishment of The Kanban rule. The fabrication of pull mechanism and rule is crucial in order to ensure the Kanban circulation is smooth and uninterrupted as well as for visualization purposes [17]. Finally, evaluation of the Kanban system performance was carried out using lean metric. Three metrics used are manufacturing lead time, inventory level and space of inventory. The identification of metric was done jointly by engineer and researcher. Some authors have demonstrated their lean metric to verify and justify the effectiveness of pull system in manufacturing area [6, 16].

4. Present Scenario at the case study area

BLM Cylinder Head Cover assembly process is a production assembly line that produces Proton product. This assembly line consists of two stages of production. First stage is the vibration welding line that produces semi-completed parts for Proton and other customers' models. The second stage is the final assembly line that is used to produce Proton products. The major process flow is sketched in figure 1.

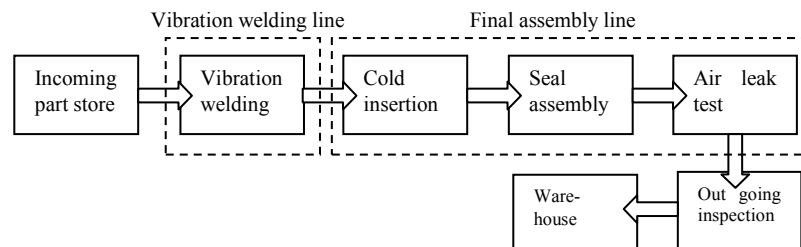

Figure 1. BLM Cylinder Head Cover assembly process flow.

Both production lines are currently running on push systems. Planning schedule is used to authorize production of specific quantity or batch quantity. The batch of completed parts is then pushed to next process until the last manufacturing area which is the warehouse. Change-over activity is required at both production lines to switch production of part. However, the planner currently plans the schedule to produce one type of part per day in order to reduce frequency of change over and minimise loss of production time.

Based on observations at production floor, flow of material through process was disturbed by accumulation of Work In-Progress (WIP) part or product on floor. This was due to the current planning schedule that is used to authorise production. It has forecast well in advance according to customer forecast order, which is against lean manufacturing principles. As a result, inventory was high, long lead time required to accomplish customer order and large space needed to accommodate finished goods at warehouse. Continuous flow system which was adopted at the production floor was not sufficient to enhance manufacturing performance in terms of lead time and inventory. This problem and discussion can be seen in previous journal and book [3, 15]. Therefore, this contributes to lower efficiency of manufacturing capability in meeting fluctuations in demand. For example, Alvarez *et al* [16] discussed the impact of material flow to operational excellence.

Due to this, the management had decided to adopt a pull system through implementation of kanban system in order to improve their manufacturing performance and also meet customer's need. With the support from UMW Toyota team, the activities were initiated in 2011.

5. Implementation of kanban system

The objective of this research is to demonstrate gains through the Kanban system. However, this paper also discusses how the Kanban system was established and implemented at the study site. Therefore, the researcher would like to present steps of activities prior to kanban system implementation.

5.1 Designing Kanban flow

The design of the Kanban flow was based on current situation at study site. Three criteria such as distance of process, method of operation and method to convey information from downstream to upstream were taken into consideration while designing the flow. The purpose was to determine Kanban waiting point in flow. Through discussion between engineer and researcher, important criteria were defined for establishing Kanban flow.

5.2 Gathering relevant parameter of manufacturing and customer

As a start, gathering of relevant manufacturing parameter was done at production area (refer table 1). Production volume collection was then collected by referring to forecast demand. For this case, 3 consecutive months of forecast demand was obtained (refer table 2 and table 3). The reason is to avoid frequent change of takt time at production line due to limitation of current process layout. However, takt time has been reviewed by quarterly in order to prevent over inventory and over production.

Table 1: Manufacturing Parameter.

Parameter	Final assembly line	Vibration welding line
Inventory (Finished goods or WIP)	1780 units	4840
Customer delivery	120 units	-
Working hours	10.25 hours	13.25 hours
Working days	19 days	19 days
Hourly production output	60 units	80 units
Change-over time/setup time	5 minutes	70 minutes
Part variants produce at final assembly line	3 variants of product	6 variants of semi-completed part
Processing time	171 seconds	180 seconds
Container capacity	5	5 (Proton part only)

Table 2: Forecast demand for finished goods.

Part no.	January	February	March
11001-PTN	4125	4080	2640
11003-PTN	5280	5040	4440
11004-PTN	1090	1405	2010

Table 3: Forecast demand for semi-completed part.

Part No.	Customer	January	February	March
PC180	Proton	4125	4080	2640
PC224	Proton	5280	5040	4440
PC225	Proton	1090	1405	2010
SA050	Perodua	6545	5745	5822
90001-SAP	Sapura	5200	2000	1000
12001-PTN (other product of Proton)	Proton	1000	1030	1050

Based on table 1, working hours for both production lines were different although hourly output for vibration welding line is higher than final assembly line. This is due to the production volume for both lines being different because the vibration welding line is used to cater for product not only for Proton models, but for other customers such as Perodua and Sapura. The production loss time due to setup time also has contributed to additional of working hours at vibration welding line.

The highest volume among 3 consecutive months (refer table 2 and 3) was selected to defined takt time. This is to ensure that manufacturing process is able to supply customer product during peak volume.

This plant currently supplies material or sends finished goods to warehouse every 15 minutes since continuous flow of product was adopted at the production floor. Thus, withdrawal time of each process occurs every 15 minutes. However, the time would be reduced when material handling system was improved.

5.2 Calculating number of kanbans to determine optimum level of inventory

To ensure that manufacturing pace is based on actual customer needs, it is essential to defined the number of Kanban and inventory level in the Kanban system. The Kanban number should tally with inventory in order to create smooth Kanban circulation and efficiently implementing Just-In-Time production.

Hence, the model of calculation that is based on the Toyota formula was used. Basically, the model is used to determined optimum number of Kanbans in the system. In the first step, batch factor or part interval was defined (refer to Eq. 1). Possible number of change-over was defined according to a few factors such as available time for change-over activity, current capability of machine to switch production and as well as company policy. The method to determine possible number of change-over has been described by Art Smalley in his book [15]. For this case, possible number of change-over for final assembly and vibration line were 13 and 4 times respectively. Therefore, part interval at final assembly line was defined as follows;

$$\text{Batch factor} = \frac{\text{Number of parts}}{\text{Possible number of change - over a day}} = \frac{3}{14}$$

$$\text{Batch factor} = 0.21$$

Table 4: Part Interval

Production line	Part interval
Final assembly line	0.21
Vibration welding line	2

Following on from table 4, the amount of batch or lot size for each part could now be determined. The value shows lot size factor, in which the smaller the value of part interval, the smaller the lot size has to be produced. Takt time was then determined for basic parameter in kanban system [16]. The takt time value is determined by Eq.2. The calculation of takt time for part 11001-PTN as follows;

$$Part\ takt\ time = \frac{Available\ time}{Part\ demand} = \frac{36900\ seconds}{217} = 170\ seconds/unit$$

Table 5: Takt time

Part number	Part Takt time
11001-PTN	170 seconds/unit
11003-PTN	132.8 seconds/unit
11004-PTN	348.8 seconds/unit
PC180	386.9 seconds/unit
PC224	302.3 seconds/unit
PC225	794.0 seconds/unit
SA050	243.9 seconds/unit
90001-SAP	305.9 seconds/unit
12001-PTN	1520 seconds/unit

Once part interval and takt time were defined, next step is calculation of PIK and PWK using Eq. 3 and 7. A few parameters, however, has to be defined using Eq. 4, 5 and 6 prior to PIK calculation. Hence, the appropriate number of PIKs was obtained. On the other hand, calculation of PWK was done by referring Kanban waiting point in Kanban flow. The determination of optimum kanban waiting has to be made in order to justify the necessity in the system.

The following shows calculation of PIK and PWK for 11001-PTN;

$$PIK = ((W_k + T_L)/T_T + \alpha)/c + T_w$$

T_L = Setup time + Processing time + Waiting time parts equal to container capacity
 $T_L = 180\ seconds + 114\ seconds + 228\ seconds = 522\ seconds$

$$W_p = \left(\frac{Part\ interval \times Part\ demand}{c} \right) \times 2 \times \frac{Part\ demand}{Total\ demand}$$

$$W_p = \left(\frac{0.21 \times 217}{5} \right) \times 2 \times \frac{217}{601} = 7$$

$$T_w = \left(\frac{Part\ interval \times Part\ demand}{c} \right) - 1 + W_p$$

$$T_w = \left(\frac{0.21 \times 217}{5} \right) - 1 + 7 = 16$$

$$PIK = ((1080 + 522)/170 + 30)/5 + 16$$

$$PIK = 25$$

$$PWK = (D + K_w + \alpha)/c$$

$$PWK = (152 + 53 + 217)/5$$

$$PWK = 84$$

Table 6: PIK and PWK number

Part No.	Production line	PIK number	PWK number
11001-PTN	Final assembly	25	84
11003-PTN	Final assembly	31	108
11004-PTN	Final assembly	13	41
PC180	Vibration welding	127	-
PC224	Vibration welding	171	-
PC225	Vibration welding	58	-
SA050	Vibration welding	18	-
90001-SAP	Vibration welding	42	-
12001-PTN	Vibration welding	2	-

Based on table 6, PIK number for semi-completed part is higher than finished goods. This is due to the lot size for each part at vibration welding is bigger than that at final assembly line. Consequently large inventory was built up to waiting cycle of part replenishment. The numbers of PIK and PWK were also different for finished goods. PWK number is higher than PIK because the company policy was to prepare 1 day worth of stock at inventory area in order to keep up supply of product although a breakdown has occurred. Therefore, they could maintain on time delivery within that day and have time to rectify the problem.

5.3 Establishing pull mechanism and rule

Before the Kanban pull system is realized on manufacturing floor, establishing their mechanism and rule is needed in order to assist smoothen out the Kanban activity. It has been reported that production lines assisted by pull mechanism were more effective [10]. On the other hand, a visual factory would create communication support system between actual process and employee. Therefore, everybody is aware of production condition at real time [17].

For the start Kanban card was designed and prepared. There are many guidelines on how to establish Kanban card [15, 16], and the design and information in card will vary since all organizations are different. The following is the guideline used to prepare Kanban card at this study site. This guideline was provided by UMW Toyota team.

- Customer information such as customer, customer product name and type of model,
- Product information such as part name, part picture and quantity per packing,
- Production process address and storage area.

All information at card must be clear and correct in order to help the user to send kanban at affected production line. Quantity of PIK and PWK card were based on PIK and PWK number respectively. Figure 2 shows an example of kanban card used in this case study.

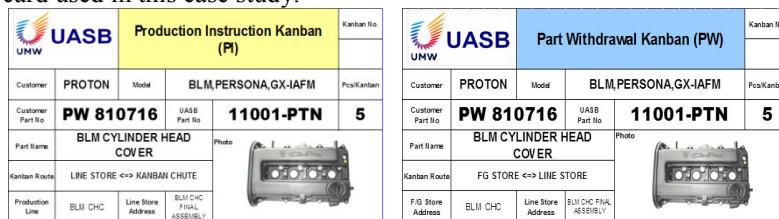

Figure 2: Example of PIK and PWK

Heijunka post was then established. The purpose of this tool is to prevent uneven demand from actual market by leveling the production volume throughout the time. To establish Heijunka post, the guideline as follows;

- Define Heijunka pitch interval by measuring withdrawn cycle time,
- Determine number of pitch intervals by taking available time of final assembly divided by withdrawal time,
- Determine frequency of Kanban delivery to Heijunka and Kanban loading according to future state design and current delivery operation,
- Determine sorting number for Kanban loading using UMW Toyota approach,
- Indicate withdrawal time according to pitch interval,
- Visualize customer information such as demand, customer name,
- Visualize production line information such as break time, part name, production line name,
- Allocate fluctuation area for balance of Kanban card

Therefore, pitch interval was 15 minutes and total number of pitches was 41. Therefore, total number of slot at heijunka post was 41. The followings table shows frequency of kanban delivery and Kanban loading time.

Table 7: Frequency of Kanban delivery and Kanban loading time

Trip	1	2	3	4
Time of delivery to customer	10.00 am	2.10 pm	9.00 pm	2.30 pm
Preparation time of delivery	8.00 am	12.00 pm	6.00 pm	9.00 pm
Kanban delivery	8.40 am	1.00 pm	8.40 am tomorrow morning	8.40 am tomorrow morning
Kanban loading	8.40 am	1.00 pm	-	-

Due to frequency of kanban delivery at twice per day, slot numbers has been divided into two groups to ensure demand is leveled and mix of production. As a result, slot number per kanban delivery was 21 slots. Figure 3 shows sketch of Heijunka post board.

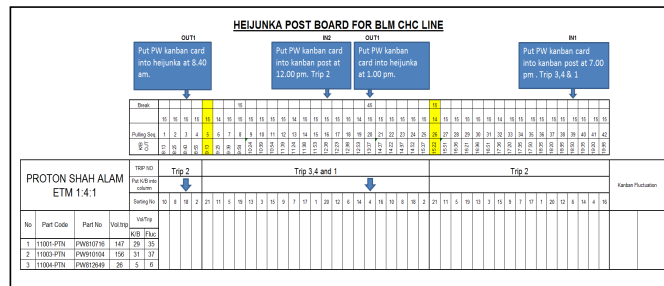

Figure 3: Sketch of Heijunka post board.

Next was fabrication of Kanban post based on Kanban delivery (refer table 7). This tool was used as temporary collection post. PWK card which was generated by pulling of goods at inventory was then put into Kanban post before delivers to Heijunka post.

KANBAN POST						
Part No:	11001-PTN	11003-PTN	11004-PTN			
Trips:	3,4 & 1	2	3,4 & 1	2	3,4 & 1	2
Heijunka Setup time:	8.40 am	1.00 pm	8.40 am	1.00 pm	8.40 am	1.00 pm
Sent to Heijunka board:	BLM CHC line	BLM CHC line	BLM CHC line	BLM CHC line	BLM CHC line	BLM CHC line
Kanban IN @ 7 pm & 12 pm:						
Kanban OUT @ 8.40 am & 1 pm:						

Figure 4: Sketch of kanban post.

Lot formation post is a tool to prioritize the part according to lot size. Thus, this tool was required at both production lines due to change-over activity. The guideline to establish lot formation tool can be;

- Visualize lot size number (in Kanban),
- Visualize production information such as part number,

LOT FORMATION POST									
BLM CHC FINAL ASSEMBLY LINE									
Lot size:	9 kanban			10 kanban			2 kanban		
Part No:	11001-PTN			11003-PTN			11004-PTN		
Kanban IN:									
Column	1	2	3	4	5	6	7	8	9
	1	2	3	4	5	6	7	8	9

*Note: 1 kanban per column

Figure 5: Sketch of lot formation post at final assembly line.

Next tool was the Kanban chute. The tool is used to arrange part sequence in 'First In First Out' manner as well as to visualize current performance of production line. Color signs were used to indicate current status of production line performance. The following is description of color at Kanban chute and figure 6 shows example of Kanban chute used at study site.

- Green color shows that cycle time is equal or below than takt time,
- Yellow color shows that cycle time is above than takt time,
- Red color shows that cycle time is higher than takt time or production breakdown has been occurred. Immediate action need to carry out to avoid stock-out.

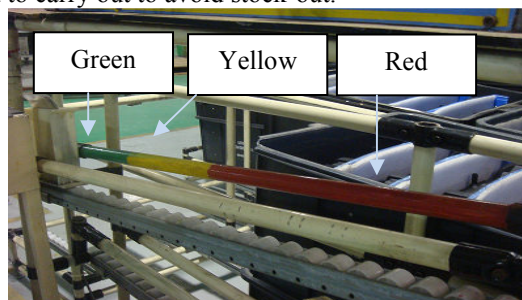

Figure 6: Kanban chute.

The final stage of the Kanban system development was setting up Kanban rule. Kanban rule is used to govern and manage the activity on floor. Hence, it would assist production personnel become aligned with the goal of the system. The following shows figure of the Kanban system and rule.

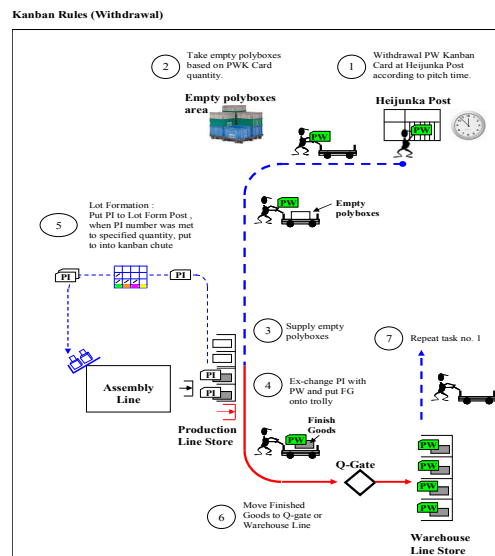

Figure 7: Kanban Rules

6. Result and Discussion

In this section, the result after kanban system implementation is discussed. The case study results have been evaluated using lean metric parameter. Three lean metrics has been identified which are manufacturing lead time, inventory level and space of inventory. A comparison between two conditions was carried out to validate if the manufacturing performance had improved or deteriorated. The two conditions are before and after implementation of the Kanban system. The outcomes of the results were appeared in figure 8.

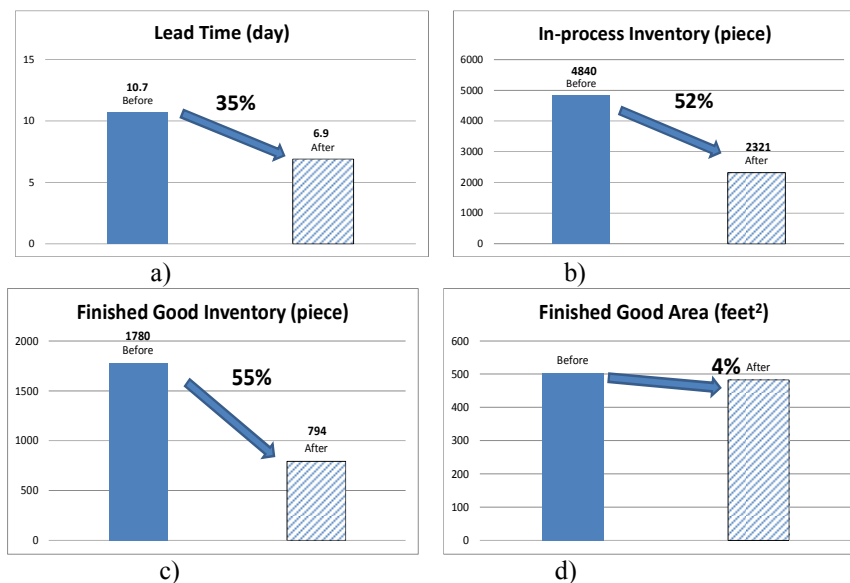

Figure 8: % of reduction; a)Lead time, b)In-process inventory, c)Finished good inventory, d)Finished good area. Lead time (manufacturing lead time) has been reduced as seen in 8(a). The lead time is reduced from 10.7 days to 6.9 days. The reduction of lead time shows that it could response to customer need. Thus efficiency increases and production process became easier by producing based on Kanban signal [2]. There are also significant improvements recorded at inventory level, in which in-process and finished goods inventory were reduced by 52% and 55% respectively (see figure 8 (b) and (c)). For in-process inventory, total of WIP was 4840 pieces, however after the Kanban system was adopted the WIP decrease to 2321 pieces. Finished goods inventory was reduced from 1780 pieces to 794 pieces. This resulted from the adoption of PIK card and PWK card that were used as authorization of production. The production at both lines are initiated when kanban signal appear. The metric of finished good area also decreased after introduction of kanban system. As shown in figure 8(d), the area decreased from 504 square feet to 483 square feet. This resulted from replenishing those items that had been

consumed by customer, not forecast number. Therefore, quantity of finished goods to store also has been reduced as well as their area.

From the results and discussion at above, can be seen that implementation of kanban system at manufacturing area would improve lead time, inventory and space. The improvement of three areas had enhanced manufacturing capability in term of resource efficiency and low operation cost.

7. Conclusion

This paper presented a real industrial case study of kanban system implementation in manufacturing site. The research findings show that kanban system is essential in ensuring the success of Just In Time production and create smooth flow of part throughout manufacturing system. Systematic and full commitment in implementing kanban system is crucial in ensuring its effectiveness; ultimately meeting customer satisfaction. The implementation shows that lead time, in-process and finished goods inventory and also finished good area will certainly improve. Subsequently manufacturing pace will be controlled and synchronized with market demand. Therefore, it can be concluded that implementation of kanban system has improved manufacturing system and this should be part of the core task of JIT practitioner.

8. References

- A. Bonvik and S. Gershwin, "Beyond Kanban-Creating & analyzing lean shop," Manufacturing and Service Operations Management Conference,
- N. Singh, K. Shek and D. Meloche, "The Development of a Kanban System: A Case Study," International Journal of Operations & Production Management, 10(7), pp 28-36.
- A. Lee-Mortimer, "A continuing lean journey: an electronic manufacturer's adopting of kanban," Assembly Automation, 28(2), pp 103-112.
- C.S Kumar and R. Panneerselvam, "Literature review of JIT-KANBAN system," International Journal of Advanced Manufacturing Technology, 32(3-4), pp 393-408.
- A. Agus, M. Hajinoor, "Lean production supply chain management as driver towards enhancing product quality and business performance: Case study of manufacturing companies in Malaysia," International Journal of Quality & Reliability Management, 29(1), pp. 92-121.
- N. Zheng, L. Xiaochun, "Comparative study on push and pull production system based on Anylogic," International Conference on Electronic Commerce and Business Intelligence (2009), pp 455-458
- Y. Frein, M.Mascolo, Y. Dallery, "On the design of generalized kanban control systems," International Journal of Operations & Production Management, 15(9), pp.158-184.
- B. Singh, S. K. Garg, S.K. Sharma and C. Grewal, "Lean implementation and its benefits to production industry," International Journal of Lean Six Sigma 1(2), pp 157-168.
- B. Stump and F. Badurdeen, "Integrating lean and other strategies for mass customization manufacturing: a case study," Journal of Intelligent Manufacturing, 23(1), pp 109-124.
- R.A Kasul and J. G. Motwani, "Successful implementation of TPS in a manufacturing setting: a case study," Industrial Management & Data Systems, 97(7), pp 274-279.
- M. Levitt and J. Abraham, "Just-in-time methods for semiconductor manufacturing," IEEE/SEMI Conference on Advanced Semiconductor Manufacturing Workshop, pp 3-9.
- J. Matzka, M. Di Mascolo and K. Furmans, "Buffer sizing of a Heijunka Kanban system," Journal of Intelligent Manufacturing, 23(1), pp 49-60.
- Dynamic simulation of a kanban production inventory system.
- M. Jothishankar, H. Wang, I. City, "Determination of Optimal Number of Kanbans Using Stochastic Petri Nets," Journal of Manufacturing System, 11 (6), pp 449-461.
- A. Smalley, "Creating Level Pull A lean production-system improvement guide for production-control, operations, and engineering professionals," THE LEAN ENTERPRISE INSTITUTE, 2004.
- R. Alvarez, R. Calvo, M. Pena and R. Domingo, "Redesigning an assembly line through lean manufacturing tools," The International Journal of Advanced Manufacturing Technology, 43(9-10), pp 949-958.
- P. Ranky, "Eighteen "monozukuri-focused" assembly line design and visual factory management principles with DENSO industrial examples," Assembly Automation, 27(1), pp 12-16.

9. Acknowledgement

This acknowledgement was expressed to UiTM for funding this research under Research Excellence Fund (Research Intensive Faculty). The work is partly from the first author for his master research at UMW Advantech Sdn. Bhd. (UASB). Special thanks to research team from faculty of Mechanical Engineering UiTM Shah Alam and UASB staffs who involve and give their support to this research.

This academic article was published by The International Institute for Science, Technology and Education (IISTE). The IISTE is a pioneer in the Open Access Publishing service based in the U.S. and Europe. The aim of the institute is Accelerating Global Knowledge Sharing.

More information about the publisher can be found in the IISTE's homepage:

<http://www.iiste.org>

CALL FOR PAPERS

The IISTE is currently hosting more than 30 peer-reviewed academic journals and collaborating with academic institutions around the world. There's no deadline for submission. **Prospective authors of IISTE journals can find the submission instruction on the following page:** <http://www.iiste.org/Journals/>

The IISTE editorial team promises to review and publish all the qualified submissions in a **fast** manner. All the journals articles are available online to the readers all over the world without financial, legal, or technical barriers other than those inseparable from gaining access to the internet itself. Printed version of the journals is also available upon request of readers and authors.

IISTE Knowledge Sharing Partners

EBSCO, Index Copernicus, Ulrich's Periodicals Directory, JournalTOCS, PKP Open Archives Harvester, Bielefeld Academic Search Engine, Elektronische Zeitschriftenbibliothek EZB, Open J-Gate, OCLC WorldCat, Universe Digital Library, NewJour, Google Scholar

