

# Enumeration of Hamiltonian Cycles on a Complete Graph using ECO method

Retno maharesi

Faculty of Technology Industry, Gunadarma University,  
Margonda raya 100 Street, Depok, West Java, Indonesia

Tel: 62-0888-1195227 E-mail: [rmaharesi@staff.gunadarma.ac.id](mailto:rmaharesi@staff.gunadarma.ac.id)

*The research is financed by Gunadarma University*

## Abstract

ECO is a method for enumerating classes of combinatorial objects based on recursive constructions of such classes. A construction for a class of Hamiltonian cycles in a complete graph consisting of  $n$  nodes is constructed based on ECO method. Here, a *Hamiltonian cycle is represented as a permutation cycle of length  $n$  whose permutation and its corresponding inverse permutation are not distinguished*. Later, this construction is translated into a succession rule. The final goal of this paper is to determine the generating function of Hamiltonian cycles and it is achieved by making use of the ordinary generating function of a permutation class and the exponential generating function of the infinite sequences of 1s.

**Keywords:** *ECO method, Hamiltonian cycle, cycle permutation, generating function, succession rule.*

## 1. Introduction

One of the strategies that can be used to find an optimal solution of TSP problem of a simple graph is by listing all the Hamiltonian cycles contained in a complete graph whereas some of its edges were removed. Here the number of nodes in the complete graph must correspond to the nodes belong to the actual TSP problem. This is because the complete graph whose some edges are deleted corresponds to the graph of the TSP problem, The object list can be linked indirectly with object counting (enumeration), by means knowing the number objects need to be listed. From our study, the counting of the Hamiltonian cycles on a simple graph needs as well the calculation of the same objects first applied on the corresponding complete graph. A known way for calculating Hamiltonian cycles on a complete graph is performed using graph theory. In this paper ECO method will be used to enumerate all the Hamiltonian cycles contained in a complete graph. The problem need to answer here is concerning to the enumeration of all Hamiltonian cycles present in a complete graph using ECO method.

The aims of this research are to obtain the counting function of all Hamiltonian cycles in a complete graph of  $n$  nodes,  $K_n$  based on the associated generating tree and to determine its generating function in the close form.

The outlines of the paper are as follows: First, we define an object, in this case, a Hamiltonian cycle, in terms of a cycle permutation of length  $n$ . Second, based on the observation on the new representation of this Hamiltonian cycle, the chance for an implementation of the ECO method is investigated. Third, successions rule that

describes how the number of Hamiltonian cycle objects according to its size being obtained from the ECO generating tree. And last, the closed form of the generating function corresponds to the counting function obtained, based, on the succession rule is given.

## 2. LITERATURES REVIEW

Here some of the important results gathered from some literature study are presented

**Definition 1:** A permutation of set  $S = [n] = \{1, 2, \dots, n\}$  is a bijection  $\pi: S \rightarrow S$ .

**Theorem 1:** The set of all permutation  $[n]$ ,  $S_n$  with composition operation function forms a symmetric group.

As an example permutation  $\pi = 51234$ , elements constructing this permutation are:  $\pi(1) = 5$ ,  $\pi(2) = 1$ ,  $\pi(3) = 2$ ,  $\pi(4) = 3$  dan  $\pi(5) = 4$ . For simplifying the written expression of bijection, two rows notation ascan be used, as follows

$$\begin{pmatrix} 1 & 2 & 3 & 4 & 5 \\ 5 & 1 & 2 & 3 & 4 \end{pmatrix}$$

The above two rows notation eases in identifying the cycle presence, in this example the cycle is: 15-54-43-32-21, which is a cycle of length  $n=5$ . The inverse of the permutation elements are written as:  $\pi^{-1}(1) = 2$ ,  $\pi^{-1}(2) = 3$ ,  $\pi^{-1}(3) = 4$ ,  $\pi^{-1}(4) = 5$  and  $\pi^{-1}(5) = 1$ . If all elements are written in a line then by theorem 1, it forms a permutation as well. Hence, interms of two rows notation, it can be written as below

$$\begin{pmatrix} 1 & 2 & 3 & 4 & 5 \\ 2 & 3 & 4 & 5 & 1 \end{pmatrix}$$

From two rows notation for the inverse permutation, it can be seen a cycle of length  $n=5$  i.e., 12-23-34-45-51. By writing the inverse permutation using the two rows notation, it provides self interpretation that is, the first row denotes the set of starting points while the second row denotes **the set of destination points**. As a result, a cycle permutation of length  $n$  also forms a closed path, e.g., 1-5-4-3-2-1. This cycle permutation (51234) is obtained from the second row. Both, cycle permutation and its inverse permutation contain five same edges, where in this example it is: 12-23-34-45-51. The following theorem [stirling first kind number] below,

**Theorem 2.** [Stirling first kind number] If  $a_1, a_2, \dots, a_n$  are non negative integers such that  $\sum_{i=1}^n i.a_i = n$ . Then the number of permutation  $[n]$  containing  $a_i$  cycles of length  $i$ ,  $i \in [n]$ , is equal to  $\frac{n!}{a_1! a_2! \dots a_n! 1^{a_1} 2^{a_2} \dots n^{a_n}}$  ..

According to theorem 2, the number of cycle permutations of length  $n$  whereas all edges forming a closed path is equal to  $[Hn] = (n-1)!$  Because the inverse permutation is excluded, as a consequence, this result must be divided

by 2 in order to obtain the number of Hamiltonian cycles in a complete graph of size  $n$ , i.e.,  $|H_n| = (n-1)!/2$ . Based on this result, it can be concluded that if  $K_n$  is a complete graph, then an object combinatorics, Hamiltonian cycle,  $h_i$  is a permutation which contains one cycle of length  $n$  but its inverse permutation is not accounted.

## 2.1. ECO method and the succession rule

ECO method can be used to enumerate combinatorial objects which are constructed recursively according to their sizes. Every object can be obtained through objects of smaller size, e.g., by making a local expansion. If its recursive construction follows a known order, hence it can be encoded in a formal system, known as succession rule. The succession rule dictates the object construction of greater object size. To see the detail how the ECO method works visit works of [Ber07], [Duc07] and [Ban07].

ECO method firstly presented in [BDLPP1], where various problems concerning with enumeration of  $k$ -coloring of all Motzkin paths were able to be solved. A general metodologi for enumerating plane trees has been presented in [BDLPP2], and a survey focusing on the application of ECO methods which included many examples of enumeration problems can be found in [BDLPP] and [Vaj 08] presented a simple Gray code of some simple combinatorial such as a certain type of Dick path objects based on ECO description of those object structures.

**Lemma 1.** *Hamiltonian cycle in a complete graph is a permutation containing a cycle of length  $n$  where the permutation and its inverse permutation are not distinguished.*

**Proof:** Based on theorem 1, every permutation cycle of length  $n$  owns an inverse permutation cycle of same length too. By taking an arbitrary example  $p_1$ , a permutation cycle of length  $n$ , i.e.,  $p_1 = \begin{pmatrix} 1 & 2 & \dots & n-1 & n \\ 2 & 3 & \dots & n & 1 \end{pmatrix}$  and its inverse bijection,  $p_1^{-1} = \begin{pmatrix} 1 & 2 & 3 & \dots & n \\ n & 1 & 2 & \dots & n-1 \end{pmatrix}$ , it can be seen that those permutations both have  $n$  same edges i.e., 1-2, 2-3, ...,  $n-1$ . This is always right since in the bijection mapping, an inverse can simply be obtained by looking at elements on the first row (domain of the bijection mapping). From theorem 2, the number of cycle permutations of length  $n$  is equal to  $(n-1)!$  Then by recalling that the total number of permutation and its inverse permutation pair should be equal, as obtained by theorem 1, hence 2 is used as a dominator on the result of counting the total number of cycle permutations of length  $n$  based on theorem 2, i.e.,  $(n-1)!/2$ . This value indicates the number of Hamiltonian cycle containing in a complete graph  $K_n$ . Hence the statement in Lemma 1 is proven. ■

The number of cycle permutations of length  $n \geq 3$  in a complete graph  $K_n$  is found as an infinite sequence of positive integer numbers: 2, 6, 24, 120, 720, 5040, 40320, 362880, (see in wolfram web site). It should be clear if for those figures, all are divided by 2, i.e., 1, 3, 12, 60, 360, ...  $(n-1)!/2$  then the new sequence of positive integer numbers denote the number of Hamiltonian cycles containing in a complete graph  $K_n$  of size  $n \geq 3$ .

Lemma 1 will be used to construct Hamiltonian cycles of size  $n$  in the next part. The reason why to apply ECO method for the enumeration problems of Hamiltonian cycles, which seems here can be obtained as explained above is instead of only counting objects, the object codes can also be obtained, which will be useful for later analysis of the application of enumeration problem involved more complicated object description.

## 2.2. Operator ECO and its generating tree

Suppose  $O$  is a combinatorial object class and  $p: O \rightarrow \mathbb{N}$  is a bounded parameter to the  $O$ , that is the  $p$  parameter of objects of size  $n$  such that  $|O_n| = |\{O \in O: p(O) = n\}|$  is bounded. Let  $v: O \rightarrow 2^O$  is such that the operator  $v(O_n) \subseteq 2^{O_{n+1}}$ . Operator  $v$  describes how the object of smaller size makes the object of larger size.

Proposition [ECO operator]. If for every  $n \geq 0$ ,  $v$  satisfies:

1. For every  $O' \in O_{n+1}$ , there exists  $O \in O_n$  such that  $O' \in v(O)$ , and
2. For every  $O, O' \in O_n$ , such that  $O \neq O'$  then  $v(O) \cap v(O') = \emptyset$ , hence the family set  $F_{n+1} = \{v(O): O \in O_n\}$  is partition of  $O_{n+1}$ .

Operator  $v$  that satisfies conditions 1 and 2 mentioned above, said to be the operator ECO. ECO operators generate all  $O$  objects such that every object  $O' \in O_{n+1}$  uniquely obtained from the  $O \in O_n$ . ECO operator which is doing the local expansion on an object called the active site of the object. Object construction is done recursively by the ECO operator can be described by a tree generator.

**Definition 2.** Generating tree is a rooted tree whose nodes in a certain level correspond to combinatorial objects of size  $n$ . all objects of the same size is denoted by class  $O$ .

On the generating tree, the root (level zero) represents object of the smallest size,  $m$ . Children of an object  $O$  are objects which are produced from parents  $O$  through operator  $v$ . If  $\{|O_n|\}_n$  is a sequence determined by the number of objects of size  $n$ , then  $f_O(x) = \sum_{n \geq m} |O_n| x^n$  corresponds to its generating function.

### 1.1.3 Succession rule

Operator  $v$  is often encoded by succession rule  $\Omega$ , which means, object of minimum size has  $a$  children while  $k$  objects  $O'_1, \dots, O'_k$ , resulted through  $v$ , object  $O$  such that  $O'_i$  should produce  $e_i(k)$  children, i.e.,  $|v(O'_i)| = e_i(k)$ ,  $1 \leq i \leq k$ . Succession rule  $\Omega$  is a system  $((a), P)$ , which consists of axiom  $(a)$  and set of productions. In other way,  $P$  is defined on set of labels  $M \subset \mathbb{N}^+$ :

$$\Omega = \begin{cases} (a) \\ (k) \mapsto (e_1(k))(e_2(k)) \dots (e_k(k)) \text{ for all } k \in M \end{cases}$$

, where  $a \in M$  is a certain value and  $e_i$  is a function  $M \rightarrow M$ .

An important property belong to the succession rule is related to consistency principle, see [Fer05]. That is, every label  $(k)$  must produce exactly  $k$  elements. Hence succession rules is isomorphism with generating tree

whose root is labeled by axiom ( $a$ ), and nodes with ( $k$ ) label produces  $k$  children of next tree levels. Each child node's label corresponds to a member of multi sets ( $e_1(k), \dots, e_k(k)$ ). The term active site, where the local expansion presents, is sometimes referred to the set of productions. Succession rule can be used to obtain a sequence  $\{f_n\}_n$  of positive integers where  $f_n$  represents the number of nodes on level  $n$  of the generating tree, which is written in terms of generating function as  $f_G(x) = \sum_{n \geq m} f_n x^n$ .

### 3. RESULTS AND DISCUSSIONS

#### 3.1 Eco Operator for a Class of Hamiltonian Cycles on a Complete Graph $K_n$

[Fle, et.al 93] used symmetric minimal difference operation between two different sub graphs of a complete graphs of  $n$  nodes for generating Gray code of Hamiltonian cycle objects. In this investigation, representation cycle permutation of length  $n$  based on Lemma 1 is used. This representation provides flexibility in terms of the object coding, in this case a Hamiltonian cycle. This representation also enables for Johnson–Trotter scheme to be applied for objects generating of any  $n$  size. A close example with this problem of generation is the generation permutation objects of  $n$  length as given below.

Here generating tree of permutation objects can be obtained using the scheme by starting at the smallest object of size 1. This involves one permutation  $S_1 = \{1\}$ . For permutation of size 2, a new element i.e., 2 is included. This is done by putting element 2 to the left side and to the right side of of permutation [1], to yield  $S_2 = \{12, 21\}$ . The same way is applied for permutation of size 3, the permutations at previous size define the position of the third element, i.e., 3 to obtain two disjoint subsets:  $\{312, 132, 123\}$  and  $\{321, 231, 213\}$ , whose union is a class of permutation of size 3. So, there is  $N$  ways to produce permutation of length  $N$  based on permutation of length  $N-1$ , e.g.  $a_1 a_2 \dots a_{n-1}$ , as follows:

$$N a_1 a_2 \dots a_{n-1}$$

$$a_1 N a_2 \dots a_{n-1}$$

$$a_1 a_2 N \dots a_{n-1}$$

...

$$a_1 a_2 \dots N a_{n-1}$$

$$a_1 a_2 \dots a_{n-1} N$$

Generating tree of permutation objects is depicted in Figure 1.

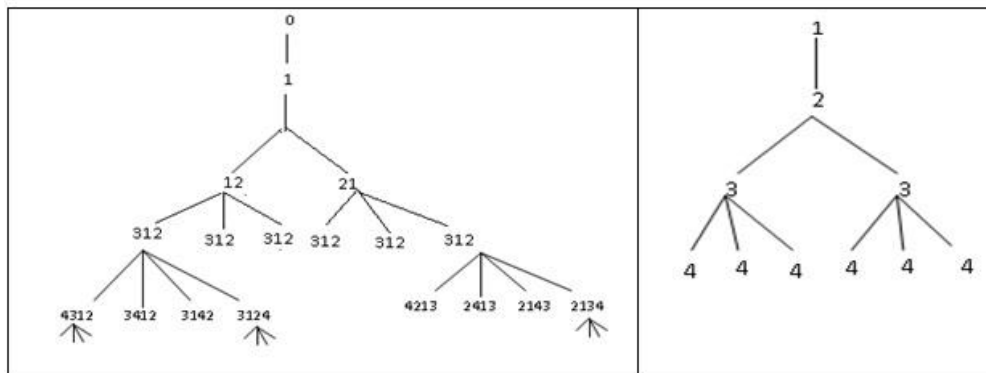

**Figure 1. Generating tree of permutation objects according to the object codes (left) and number of children produced (right)**

If nodes in the left generating tree in Figure 1 are labeled according to the number of the produced child nodes, then the right generating tree can be obtained. Hence generating tree for permutation objects can be written in terms of succession rule given by Equation (1),

$$\Omega = \left\{ \begin{array}{l} (1) \\ (k) \end{array} \right\} \mapsto (k+1)^k \quad (1)$$

The above succession rule  $\Omega$  read as the smallest object has a branch as stated by axiom (1) and objects with labels (k) produce objects with label (k+1) as many as k times. This can be verified that the number of permutation objects of length n are ordered in a sequence as 0!, 1!, 2!, 3!, ..., n! Based on object representation stated in Lemma 1, a similar way as of the generating permutation objects of length n can be applied for the case of Hamiltonian cycle objects.

Starting from permutation [3], it results into two cycles i.e., 312 and 231. Based on Lemma 1,  $\pi_1$  and its inverse permutation  $\pi_1^{-1}$  contain the same path i.e., 31-12-23. The number of ways for writing Hamiltonian cycles which contain in  $S = [3]$  can be regarded to follow circular permutation of 3 elements. It can be seen that permutation differ if an element is fixed while the others (n-1) elements being permuted, in this case results to (n-1)! circular permutations. According to Lemma 1, the number of Hamiltonian cycles made of the 3 elements is equal to . Cycle permutation of length  $n = 3$  are {231, 321}. Lemma 1 causes the two cycle permutations

be regarded as one object of Hamiltonian cycle. As a result, if its permutation being represented as a line permutation, the number of ways in rewriting a Hamiltonian cycle is equal to  $2*n = 6$ . Here number 2 denotes the number of clock directions, hence its label set,  $L(231, 321)$  can be listed as {123, **231**, 312, 132, **321**, 213}. In the same way, the number of ways in writing Hamiltonian cycle of size 4 is 8, Hence generally, object of size n has  $2n$  ways to written in terms of a Hamiltonian cycle. Figure 2 explains the relationship between Hamiltonian cycle for object of size n and  $2n$  ways of its written expressions

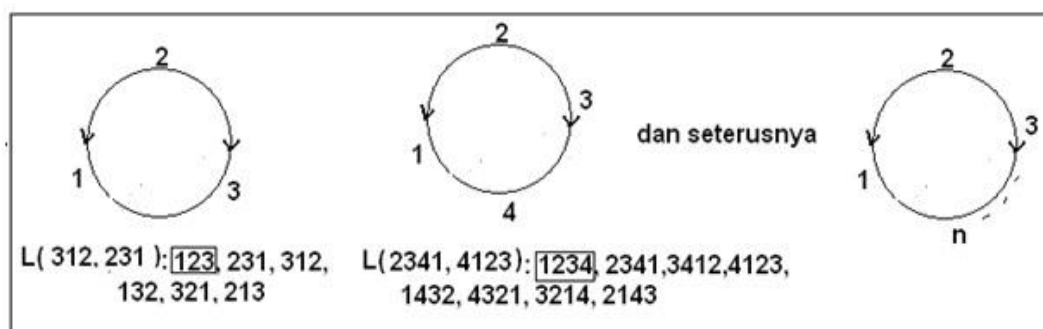
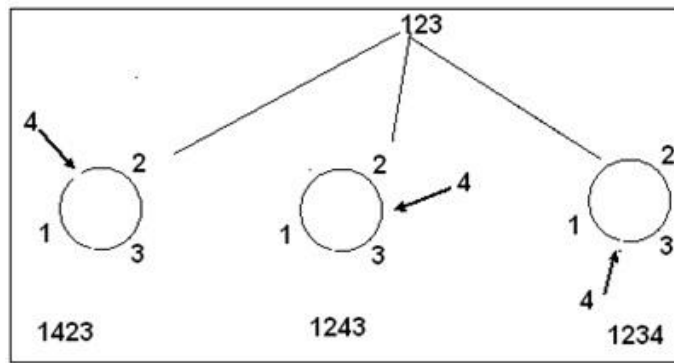

**Figure 2.** Sets of Labels ( $L(\pi, \pi^{-1})$ ), for pair of cycle permutations of length  $n = 3, 4, \dots$  on a complete graph  $K_n$ ,

In Figure 2, for  $n = 4$ , the pair of cycle permutation and its corresponding inverse is  $(2341, 4123)$ . This pair of permutations has the same closed path representation, so the corresponding object label can be written as a line permutation in 8 ways. The set of labels produced by  $(2341, 4123)$  is  $L(2341, 4123) = \{1234, 2341, 3412, 4123, 1432, 4321, 3214, 2143\}$ . For the others pairs of cycles in  $S_4$ , i.e.,  $(3421, 4312)$  and  $(3142, 2413)$  have a similar way of writing expression.

Johnson–Trotter generating scheme is implemented, starting from the smallest object of size  $n = 3$ , the written convention of Hamiltonian cycle object is done by choosing an alternatives among 6 ways, as explained above. In this paper, a Hamiltonian cycle is written as a line permutation started using number 1. Based on this scheme, the smallest object is written as  $123$ . If element 4 is inserted between element 1 and element 2, then results a Hamiltonian cycle  $1423 \in L(3142, 2413)$ , similarly by inserting 4 between element 2 and element 3 an object  $1243 \in L(3142, 2413)$  is obtained, and also from object  $123$  if element 4 is inserted at the end position to give object  $1234 \in L(2341, 4123)$ . To generate object of size  $n = 5, 6, 7, \dots$  element  $5, 6, 7 \dots$  need to be inserted in between the two positions of the smaller objects considered as a circular permutation. It is straight forward to see that on a class of objects of size  $n = 5$ , contains 12 objects of Hamiltonian cycles i.e.,  $\{15423, 14523, 14253, 14235; 15243, 12543, 12453, 12435; 15234, 12534, 12354, 12345\}$ .

The generating tree of objects whose structure follows the arrangement of  $n$  circular elements such as this Hamiltonian cycle, have  $n$  active sites, valid for objects with size  $n \geq 3$ . Hence, based on ECO method as described above, the insertion of a new element in between the element positions give  $n$  new different objects. Figure 3 describes the formation of children nodes of object  $123$ .

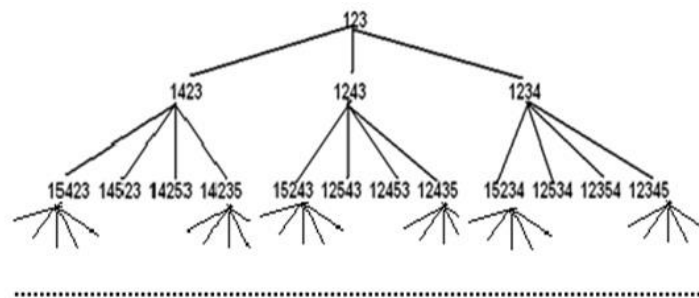

**Figure 3. Generating Hamiltonian cycles object using Johnson-Trotter scheme for initial object 123, insertions element 4 gives 3 new objects: 1423, 1243, 1234.**

This leads to the conclusion that labeling system on the Hamiltonian cycle objects  $h_n$  started from the smallest object size among six choices of object representations  $\{123, 132, 213, 231, 312, 321\}$  is isomorphism with nodes within the same levels in the generating tree of Hamiltonian cycle objects on a complete graphs  $K_n$  for  $n = 3, 4, \dots$ . Based on this isomorphism, a succession rule for labels construction of each node in the generating can be obtained.

### 3.1. SUCESSION RULE FOR ECO OPERATOR

Figure 4 shows a generating tree of a class of Hamiltonian cycle whose smallest object ( $n = 3$ ) is labelled as 123 and Figure 5 shows a generating tree with labels represent the number of children nodes produced by objects in Figure 4.



**Figure 4. Generating tree of Hamiltonian cycles belong to a complete graph  $K_n$  where the nodes are labeled as the object itself started from object with label 123**



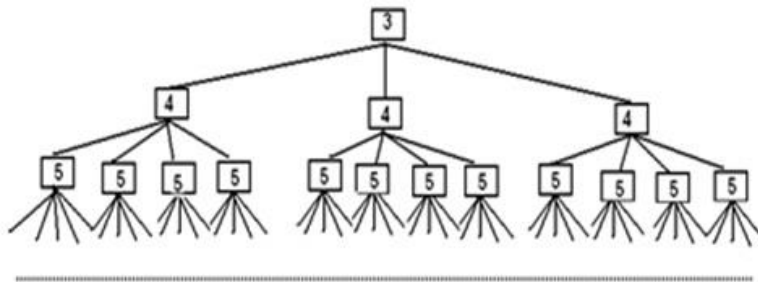

**Figure 5. Generating tree of Hamiltonian cycles belong to a complete graph  $K_n$  where the nodes are labeled as the number of children nodes started from object of size 3.**

The succession rule for the above generating tree of Hamiltonian cycle started from the smallest node  $n = 3$  is given by Equation (2)

$$\Omega = \left\{ \begin{matrix} (3) \\ (k) \rightarrow (k+1)^k \end{matrix} \right. \quad (2)$$

This succession rule is read as follows: The smallest object has node labelled as (3), this follows the number of children nodes that will be produced in the next level of the tree. Therefore, a node labeled as (k) produces k children nodes labeled as (k+1), where  $k \geq 3$ .

Based on ECO method it is possible to generate combinatorial objects, using an algorithm which is termed as *constant average amortized time* (CAT). For the enumeration purpose it will not be done here. The system of object labeling as given in this paper, which is applied on a class of Hamiltonian cycle  $H_n$ , on a complete graph  $K_n$ , can separate objects according to the edges contained in an arbitrary Hamiltonian cycle to yield sub classes of  $H_n$ , say  $H_{ij}$ . These sub classes can also be enumerated with the same manner as the Hamiltonian cycle object described above.

### 3.3. DETERMINING THE GENERATING FUNCTION

The generating function for all Hamiltonian cycle objects with size  $n \geq 3$  in the class  $H_n$  on a complete graph  $K_n$  can be obtained based on a sequence formed by the number of objects or nodes at every level of the generating tree. By starting at level 0, 1, 2, ..., n. The number of Hamiltonian cycle in complete graph  $K_n$ , can be obtained using the above succession rule, as set of productions, i.e., 1x1, 1x3, 1x3x4, 1x3x4x5,.... atau 1, 3, 12, 60, 360, .....

$$F(z) = \sum_{k=0}^n a_k z^k = 1 + 3z + 12z^2 + 60z^3 + 360z^4 + \dots + \frac{(k-1)!}{2} z^n \quad (3)$$

The closed form of Equation (3) needs to be obtained. But first of all, the EGF (*Exponential Generating*

*Function*) needs to find. This EGF is achieved by determining a sequence of positive integers which indicates the number of objects on every level of the generating tree as shown in Figure 1. The sequence of positive integer numbers is obtained through production sets of permutation objects on the (k) label, which starts from 0, e.g.,  $1, 1, 1x2, 1x2x3, 1x2x3x4, \dots, n!$  or  $(0!, 1!, 2!, 3! \dots, n!)$ . The ordinary generating function (OGF) then can be written as in Equation (4).

$$F(z) = \sum_{k=0}^n k! z^k = 1 + 1z + 2z^2 + 6z^3 + 24z^4 + 120 z^5 \dots + n! z^n \quad (4)$$

The closed form then can be obtained by recalling that the sequence  $(1, 1, 1 \dots, 1)$  has the following OGF:

$$F(z) = \frac{1}{1-z} = 1 + z^1 + z^2 + z^3 + \dots \quad (5)$$

But if expression Equation (5) can be changed to as of the form of Equation (6):

$$F(z) = \frac{1}{1-z} = \frac{0! z^0}{0!} + \frac{1! z^1}{1!} + \frac{2! z^2}{2!} + \frac{3! z^3}{3!} + \dots \quad (6)$$

Hence  $\frac{1}{1-z}$  is an EGF of sequence  $n!$ , which is nothing but the close form of generating function of sequence in Equation (4), i.e., the number of permutation objects of size n. By observing that sequence:  $1, 3, 12, 60, 360, \dots$  can be obtained from sequence as in Equation (4) by firstly subtracting  $(1+z)$  to the left and right part of Equation (6) and then dividing both of sides with  $2z^2$ . This result leads to the desired close form of the generating function corresponding to the sequence in Equation (3), i.e.,

$$F(z) = \left( \frac{1 - (1-z)^2}{2(1-z)z^2} \right), \text{ for } n = 3, 4, 5, \dots \quad (7)$$

#### 4. CONCLUSION

In this paper, complete graph is presented in order to simplify the analysis combinatorial of object such as Hamiltonian cycle. This presentation gives an idea how a sub graph, e.g., Hamiltonian graph can be translated in terms of combinatorics object, by mean of permutation cycle representation as presented in Lemma 1. Furthermore this enumeration study on the Hamiltonian cycle objects can give a contribution to the graph theory, in terms of the counting function for Hamiltonian cycles that exist in a complete graph  $K_n$  as given by equation (7). Furthermore result in this study can be applied to solve enumeration problem of Hamiltonian cycle according to the edges contained.

## References

- Bernini,A. et.al (2009). *An exhaustive generation algorithm for Catalan objects and others*, arXiv:math.CO/0612127v2.
- Barcucci,E. et. al (1995). *A construction for enumerating k-coloured Motzkin paths*, Lecture Notes in Comput.Sci. 959, 254-263.
- Barcucci,E, et.al(1998), *Proceedings of FPSAC*, Marne-la Vallee, later appeared on *Discrete Math. 180*, pp. 45-64: Towards a Methodology for tree enumeration.
- Barcucci,E, et, al, (1999), *J. Differ. Equations Appl. Vol. 5 pp. 435-490*, ECO: A methodology for the Enumeration of Combinatorial Objects.
- Duchi,E, (2009), *ECO method and Object Grammars: two methods for the enumeration of combinatorial objects*, Dottorato di Ricerca in Ingegneria Informaticae dell'Automazione, XV Ciclo, Universita Degli Studi di Firenze, <http://www.dsi.unifi.it/DRIIA/RaccoltaTesi/Duchi>, (Mei, 2009).
- Ferrari.L and R. Pinzani, (2005), *Catalan like numbers and succession rules*, arXiv:math.CO/0507210v1,
- Fleischner.H, et.al,(1993), *Acta Math: Generating Hamiltonian Cycles In Complete Graphs*, Univ. Comenianae, Vol. LXII, 2, pp. 155-159.
- V.Vajnovski,(2008), *Extended abstract*, Simple Gray codes constructed by ECO method.

The IISTE is a pioneer in the Open-Access hosting service and academic event management. The aim of the firm is Accelerating Global Knowledge Sharing.

More information about the firm can be found on the homepage:  
<http://www.iiste.org>

## CALL FOR JOURNAL PAPERS

There are more than 30 peer-reviewed academic journals hosted under the hosting platform.

**Prospective authors of journals can find the submission instruction on the following page:** <http://www.iiste.org/journals/> All the journals articles are available online to the readers all over the world without financial, legal, or technical barriers other than those inseparable from gaining access to the internet itself. Paper version of the journals is also available upon request of readers and authors.

## MORE RESOURCES

Book publication information: <http://www.iiste.org/book/>

## IISTE Knowledge Sharing Partners

EBSCO, Index Copernicus, Ulrich's Periodicals Directory, JournalTOCS, PKP Open Archives Harvester, Bielefeld Academic Search Engine, Elektronische Zeitschriftenbibliothek EZB, Open J-Gate, OCLC WorldCat, Universe Digital Library, NewJour, Google Scholar

