

The Use of RFID Sensors for Automatic Doorstop Application

Hedy Eko Hidayat Santoso¹ Herdi Saputra³ Amien Shofyan² Khoirul Anam² Eko Suprptono³

1.D3 Electrical Engineering Program, Electrical Engineering

2.S1 Informatic and Computer Engineering Education

3.Electrical Engineering

Engineering Faculty, State University of Semarang, Indonesia

Abstract

RFID or Radio Frequency Identification, is the process of identifying a person or object to the use of radio transmission frequency. RFID is a method which can be used to store or receive data remotely by using a device called RFID tags or transponders. Transponders that be used is a passive transponder that have limited power capacity, so it can only stores data that is generally a course ID number. Example of passive transponder is the e-ID card. In the e-ID card and chip antennas are used to capture the radio waves emitted by the RFID reader, and IC is used to store information. The application of RFID will be placed on an automatic doorstop where to open the e-ID card is used that has been registered in the database system. This tool is also equipped with sensors HC-SR04 as the cover latch automatically. The automatic latch uses a microcontroller atmega 328 (arduino) as the brain of this tool. Factor of safety, automation, and time efficiency into consideration for making this final task, where the use of the identification system is needed.

Keywords: RFID, Transponder, e-ID Card, Microcontroller, Sensor HC-SR04

1. Introduction

Technology is a result of the application of science in the form of a product for the purpose of solving a problem. These products can be salty, telephone, printing machines, robots and others. Example of technology application is an automatic latch. Such technology has been formed with many public places such as hospitals, factories, supermarkets, residential complexes, residential buildings, etc. Although it is considered safe, but in reality there are some disadvantages such as long queues and long parking, loss of vehicle registration, lost ticket that comes out of the parking machine (barcode) and others.

To avoid and anticipate the incident, the RFID (Radio Frequency Identification) could be the solution of all problems or incidents above. (Revelation Supriyanto, 2008: 158) RFID is a technology-based identification of radio waves being able to identify various objects simultaneously without required direct contact (or within a short distance). RFID does not need to use a guard or ticket (barcode) that came out of the parking machine or letter-critical vein as proof. Quite by using a transponder or tag (ID) as a key access in and out of the parking lot. Therefore, the author of this thesis tries to realize a parking lot security tools that use RFID as sensor.

The title of this thesis is "The use of RFID Sensors For Automatic Doorstop Application". With Atmega 328 microcontroller as the brain of this tool.

2. Theoretical Basis

2.1. RFID Sensor

Radio frequency identification is a term or abbreviation of RFID. RFID is a sensor that can generate and emit an electromagnetic wave. RFID sensor has several main components, these components include:

- RFID Reader: sensors which can radiate radio wave arrives once a sensor can read the data carried by the transponder.
- Transponder: a small object such as (cards, stickers, etc.), which also has been equipped with an antenna and a chip carrier of information.

RFID Reader or can be called reader station liaison between software applications with antenna will radiate radio waves to the RFID tag. Radio waves emitted by the antenna propagates in the room around it. As a result, the data can move wirelessly to RFID tags that are adjacent to the antenna.

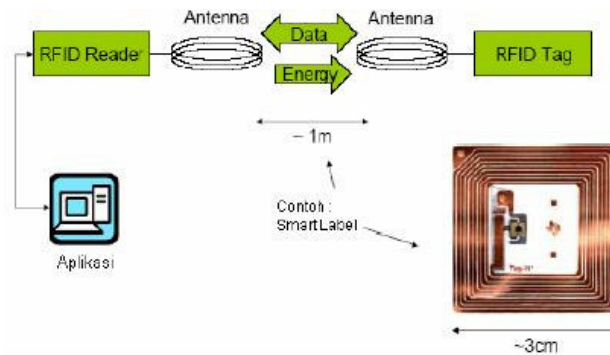

Figure 1. How RFID works

2.2. RFID TAG (transponder)

RFID TAG is a device made of IC and antenna integrated in the circuit. Electronic circuit of the RFID tag generally has memory to store data, so as a unique serial number, which has been deposited at the time of the RFID tag is produced. RFID tags may also be written and read repeatedly. There are two important parts owned by the RFID tag, namely:

- IC or an extension of the Integrated Circuit: function storing and processing information, modulating and demodulating the RF signal, take the DC voltage delivered from RFID READER through induction, and some other special functions.
- Functioning antenna receives and sends RF signals.

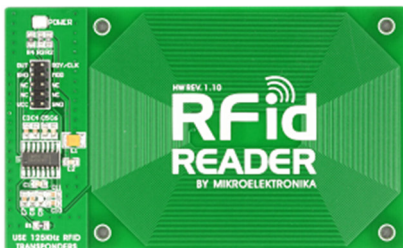

Figure 2. RFID Reader

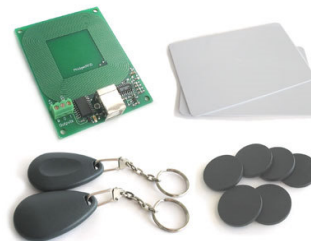

Figure 3. RFID Tag

Based on its power supply, RFID tags are classified into 2 pieces parts, among others:

- Active Tag**
 Tags are obtained from the battery voltage, thus reducing the power required by the RFID tag. The downside of this type in the RFID tag is high cost and larger size, since its function is more complex. There are more functions that can be performed by an RFID tag. The circuit in this tags will be more complex and the greater size..
- Passive tags**
 This tags are obtained from the field produced by the RFID reader. The circuit is simple, the price is much cheaper, smaller size and lighter. The disadvantage is the RFID tags can only send information in the near distance and the reader should provide additional power to the RFID tag.

Based on frequency value, RFID tags can be divided into 3 parts:

- Low Frequency tags (between 125 to 134 kHz)**
 Working frequency RFID tags located at 125 kHz frequency rang 134 kHz. RFID with working frequency in the LF band frequency range is often used for research animal tracking and tracking the delivery of an asset.
- High frequency tags (13.56 MHz)**
 Working frequency RFID tags on the HF bands located at a frequency of 13.56 MHz. RFID with working frequency of 13.56 is used where medium data rate (TAG RFID) and RFID reader (RFID Reader) is about 1.5 meters.
- UHF tags (868 to 956 MHz)**
 Range frequency in the UHF band RFID tag is located in the frequency range 850 MHz-950 MHz and 2.4 GHz. RFID with working frequency in the UHF ISM band has a very high readout speed.

2.3. Atmega 328 microcontroller (Arduino Uno)

Arduino Uno is one of labeled product. Actual Arduino is an electronic board containing a microcontroller Atmega 328 (a piece that is functionally acts like a computer) (Abdul Kadir, 2013: 16).

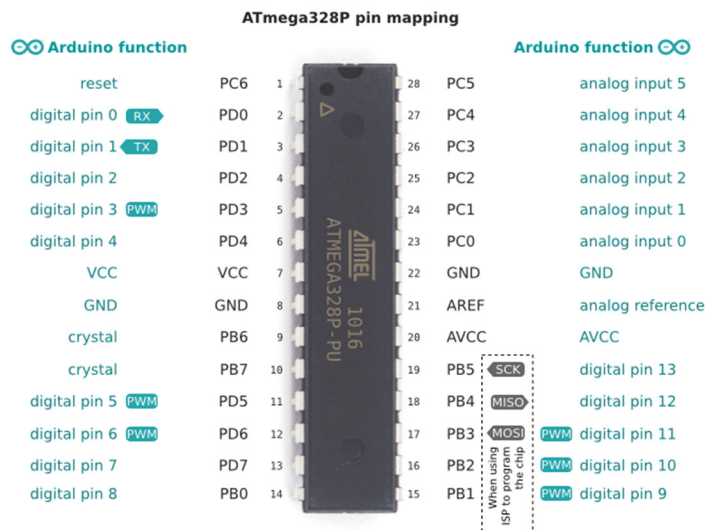

Figure 4. Port Atmega 328 Arduino

Atmega 328 has 28 pins, each pin has a different function either as port or as a function of the other. The following will explain about the usefulness of each leg on the Atmega 328:

- ✓ VCC
Is the supply voltage for the digital (5 V DC)
- ✓ GND
Is ground for all components that require grounding
- ✓ Port B
In port B are XTAL1, XTAL2, TOSC1, TOSC2, Number of port B pins are 8 pieces ranging from pin to pin B.7 B.0. each pin can be used as input and output
- ✓ Port C
Port C is a 7-bit bi-directional I / O ports in each pin there is a pull-up resistor. The pin number is only 7 pieces ranging from pin C.0 to C.7
- ✓ Reset / PC6
If RSTDISBL Fuse is programmed, then PC6 will function as I / O pins. To be attention, these pins have different characteristics with the pins located on port C. However if RSTDISBL fuse is not programmed, then the pin will function as a reset input
- ✓ Port D
Port D is an 8-bit bi-directional I / O with internal pull-up resistor. The function of this port is the same as the other ports. It is just a function of this port there are other utilities
- ✓ A VCC
In this pin functions as the supply voltage for the ADC. For this pin must be connected separately to the VCC because this pin is used for analog only
- ✓ AREF
Is the analog reference pin if using the ADC
- ✓ Memory
Atmega 328 microcontroller has 32 KB Flash memory for storing code (while 2 KB used for the bootloader)

2.4. Software Arduino Uno

To make the program (coding), a program that be used is a program belonging to the type of control on atmega microcontroller 328, so atmega 328 can organize and provide instruction to RFID and other controls.



Figure 5. Logo Software Arduino

Explanation Figure Storyboard Arduino:

- ✓ Library page is a page that contains a library program that has been provided by the software arduino uno.
- ✓ Software page is the page that will be loaded coding C ++ programming.

Language Basics of software program Arduino Uno:

1. Void setup ()
Contains the program code that is executed only once immediately after the microcontroller is executed or reset. Is part of the language C ++. The purpose of this program is to create a system of preparation or initialization program.
2. Void loop
Contains the program code that is run continuously. It is the main program.
3. Branching Instruction
Instruction if and if-else will examine whether certain conditions are met or not. If not met, then the next instruction will be skipped, but if these are met, then the next instruction to be executed.
4. Instructions for loop-loop
For loop-loop will make looping on the blocks in a certain amount, as many of its counter value.
5. Digital Input Output
 - ✓ Pinmode ()
Placed in void setup (), is used to set a base I / O digital, to run INPUT or OUTPUT. By writing format as follows:
DigitalWrite (3, HIGH); // Output a signal HIGH in D3
 - ✓ Digital Read
Used to read the incoming digital signal, use instruction digitalWrite (), with the writing format as follows:
int key = digitalRead (2); // Read the incoming signal in D2.
 - ✓ Digital Write: used to remove digital signal.
6. Communication
 - ✓ Instructions Serial.available ()
Used to obtain the number of characters or bytes that have been received at the serial port
 - ✓ Instructions Serial.read ()
Used to read data that has been received on the serial port
 - ✓ Instructions Serial.print ()
Used to print data to the serial port
 - ✓ Instructions Serial.write ()
Used to transmit data in binary form, one byte of data each shipment
 - ✓ Instructions Serial.begin ()
Used to set the baudrate or speed (9600)

2.5. HC-SR04 Sensor (Sensor Distance)

HC-SR04 is one of a series of distance sensor with the principle of ultrasonic waves, which are sensors in two parts: receiver and transmitter that has a wave function as a producer as well as a wave receiver.

Besides the physical form of the HC-SR04 ultrasonic sensor that has a 4 pin, the VCC pin as an input pin offset voltage and GND pin for grounding.

To connect the ultrasonic sensor, we just connect the VCC and GND pins to + 5V and GND arduino, and pin Trigger and Echo connected to digital pin arduino.

Calculation formula used by the sensor HC-SR04 be formulated as follows: $S = 340.t / 2$, where S is the distance between the ultrasonic sensor diffuse reflectance field, and t is the time difference antara transmitting ultrasonic waves until received by the ultrasonic receiver section.



Figure 6. Sensor HC-SR04

3. How The Application Works

The workings of the RFID sensor applications for automatic DoorStop Mechanism of action of this tool is divided into 2 parts, namely:

1. The first part of the doorstop works automatically

In this part the operation of automatic doorstop using RFID sensors and proximity sensor to operate. RFID sensor serves as a sensor that is used to scan the ID numbers on the transponders, RFID will then send the data to the mikrokontroller ID atmega 328 to validated, whether ID scanned by the reader has been registered or in other words equal to database data. If at the doorstop that automatically opens. HC-sensor SR04 function to detect a vehicle to pass through, so that the cross doorstop will close again when the sensors SR04-HC is no detect vehicles that have passed the doorstop.

Explanation of flowchart

✓ Start

The first step to operate the use of RFID sensor for automatic doorstop is an application by means of a switch rotate the shape is like a key to a motor vehicle. Then point the selector switch on the Auto mode.

✓ Atmega 328

After the automatic mode is active, atmega 328 will do its job as the control of all input and output.

✓ RFID scan data

Reader will read a series of RFID tag through the electromagnetic emission dipancarkannya. Then the reader will send instructions to the atmega 328 mikrokontroller for validated in the database.

✓ If (condition)

• Valid

If the data sent by the reader true or valid (according to the database), then the mikrokontroller will automatically run the next instruction. And if invalid or wrong then mikrokontroller will be refused or not running the next instruction.

• Not Valid

After the open cross next atmega 328 will give instruction to the proximity sensor SR04-HC to detect or no objects that cross doorstop for 20 seconds. If for 20 seconds sensor cannot detect any object, then later yan atmega 328 will give instruction to relay to close a doorstop, but if in 20 seconds still no new vehicles that crossed the doorstop, then the atmega 328 will give doorstop to hold the relay remains open.

✓ Motor rotate left

When the data is sent by the reader value valid, atmega 328 will give the signal to the relay to move the motor to spin kekiri.(open the doorstop)

✓ Limit switch (LS 1)

Function to shut down or stop revolving motion motor which rotates to the left when the cross has formed a little over 90°.

✓ Motor rotate right

When the atmega 328 sends instructions to relay the relay will then move the motor to move towards the right (close the doorstop).

✓ Limit Switch 2 (LS 2)

LS 2 serves to stop the rotation of the motor when the doorstop already form a more or less 0°.

✓ End

After a closed back, then cross atmega will reset the initialization phase and back at atmega 328 and RFID scan data.

2. The second part of the. doorstop works manually.

This section is designed as a step to anticipate when the automatic operation of an error or interruption. So if a problem occurs during automatic operation or damage the time cross pntu can still be used. On the application in use 2 button that button up and down. Which has its own function, up to open the cross and down to close the cross.

Explanation of flowchart

✓ Start

Started by turning the switch which forms such as the key of the vehicle, so that the contacts are in the position of NO (Normally Open) changed to NC (Normally Closed)

✓ Push Button (PB 1)

Button to open the doorstop.

✓ Motor rotate left

When the relay Gets the signal from the PB 1 then the relay will move the motor to spin to the left, so that the door opens.

✓ Limit Switch (LS 1)

Function to turn off the motor when the movement had formed a doorstop angle of approximately 90°.

✓ Push Button (PB 2)

- Used to close the door to cross back.
- ✓ Motor rotate right
When the relay Gets a signal from a relay then PB2 will move the motor to spin to the right, so that the door closed again.
- ✓ Limit switch (LS 2)
Function to turn off the motor when the movement was forming a doorstep or less 0°.
- ✓ End
After parker's doorstep is closed, then the work will start from PB 1 again.

4. Testing

In this step will be done testing tool in order to find out the value of efficient use of a tool entitled the use of RFID Sensor for automatic doorstep applications. And also to know the keterlaksanaan tool in accordance with the flowchart and the expectation.



Figure 7. Panel Operation Doorstop

- ✓ Power supply or power is used to turn on/off all running components. This is used for a power emergency. To switch on the power supply of the tool, turn the switch.
- ✓ Selector switch is a switch that has two NC and NO conditions that function to move or select the mode that will be used on applications doorstep.
- ✓ Push Button UP is the key to open the doorstep.
- ✓ Push Button Down is the key to closing a doorstep.
- ✓ The RFID Reader is a sensor to read RFID tags series (e-ID).

Above is a picture of the look of the panel boxes containing the main components for the operation of the doorstep. Ultrasonic sensor is a sensor used to detect or no one objects (vehicles) that are past the doorstep.



Figure 8. Poles box panel as well as the placement of Sensor HC-SR04

4.1. Manual Mode Test

At this stage the system is operated using the push-button 2 pieces up and down her pussy. Push button here serve

as a trigger to move the doorstop to be able to move up and down according to the orders given. To enter manual mode, first turn on the power switch of the lamp until the charge indicators will glow. Then on the selector switch select the manual mode, so that the indicator light Flash manual.

In the image above, there are two push button is red and green. For the red push button (Push Button Up), if pressed motor will move to the left (opposite to the direction of the clock), so the cross moves up (open). For the Green Push button (push Button downs), used to move the motor to spin to the left (clockwise), until the move down (closed).



Figure 9. Button Control to operate Mode Manual

4.2. Automatic Mode Test

Operate system using RFID tag types of e-ID as input data, where RFID tags listed have a serial number or code is as follows: 14f95146fa (one example of 7 e-ID CARD that will be tested)

RFID tags that can be used to open a doorstop is a RFID tag that is valid with the serialization code or existing in the database.

Step operation as follows :

- a. Power Switch must be in the ON State and the Selector Switch is in the Auto mode, position the sensor so that RFID will light up like drawn.



Figure 10. Button Control to operate Mode Automatically

- b. After the automatic mode is active then the next step is to bring closer the RFID Tag (e-ID) to the RFID reader module to read the series. When the readings proclaimed valid serial (serial data corresponding to the database listed in the program) then the doorstop will open.



Figure 11. Transponder value is valid

- c. If reading failed or invalid (not in accordance with the listed database data), then cross the door remains

closed, and will a dialogue appears ' access denied '.



Figure 12. Transponder value is not valid

- d. When RFID Tags were declared valid doorstop will be open for 20 seconds. If the HR sensor SR04-20 second did not detect any object of a passing vehicle, then the sensor will send instructions to the mikrokontroller to close the back door, cross is in 20 seconds if the sensor detects a new vehicle through or stop in the midst of the sensor will send instructions to the mikrokontroller to hold the doorstop remains open, and will close again when no object again.

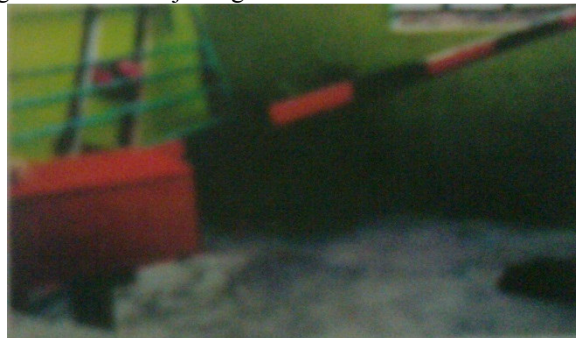

Figure 13. Doorstop move up/open



Figure 14. Doorstop move down/close

5. Evaluation

At this stage carried out evaluations of doorstop testing to ensure the tool has been built in accordance with the formulated. Here are some of his:

1. The distance reading can be done by the RFID reader RFID Tag, only to the extent of 2-2.5 cm
2. RFID Tag can open only when the doorstop RFID Tags have a serial code or in accordance with the data in the database.
3. Sensors SR04-HC can read well the existing objects on the front side (as long as the object is within less than equal to 2 meters from the location of the sensor)
4. Cross can form approximately 900 when opening and form a more or less 00 when closing
5. Selector Switches can work well in doing mode selection operation.
6. The possibility there are several risk factors that cause doorstop sometimes fail or error in the exercise of their functions.

6. Conclusion

Following the conclusion of the trial results have been done :

1. RFID based automatic doorstop used as viable suggestions to represent applications of sensors use sensors.
- 2 this doorstop has been applied in places such as public housing complex, a supermarket, a Conference Hall, etc.

Acknowledgement

Acknowledgement The authoor would like to express his great thank to Eko Supraptono.

References

- Kho Dickson, The principle of relay along with function and symbol, 2013 (<http://produksielelektronik.com>) - Access on August 26, 2014
- Abdul Kadir, Application Study of Mikrokontroller Guide and Programming Using The Arduino, Yogyakarta, Ando Offset, 2012
- Agus Purnama, The Limit Switch and Push Button, 2012 (<http://elektronika-dasar.web.id/komponen/limit-switch-dan-saklar-push-on/>) - Access on May 25, 2014
- Abi Sabrina, The Working Principle Of RFID, 2014 <http://abisabrina.wordpress.com> – Access on May 6, 2014
- Wahyu Supriyanto, Information Technology Library, Yogyakarta, Kanisius, 2008
- Didik Suyoko, Safety Door Tools Using RFID 125 Khz Mikrokontroller-Atmega 328, Elektronik Engineering, Engineering Faculty, State University of Yogyakarta, Indonesia, 2012
- Zarfani Yulias, HC-SR04 Sensors (Proximity Sensor), 2011 (<http://blog.famosastudio.com/2011/12/bengkel/menggunakan-ultrasonic-range-sensor-hc-sr04-dansdm-io/458>) – Access on May 19, 2014



Amien Shofyan was born in Semarang, at April 20th 1994. Live in Semarang. Now, Bachelor's degree in State University of Semarang, Indonesia. Has attended seminars and city level competitions to the province. Have the ability in the field of computers.