

Optimization of Zone Routing Protocol

ANUPRIYA RASTOGI

Department of Electronics and Communication Engineering, IIMT Engineering College, Meerut, Uttar Pradesh, India

ABSTRACT

Reactive and proactive protocols have several advantages in ad hoc network. Proactive protocols provide less delay and reactive protocols uses less bandwidth, but it in order to use these advantages properly, it is better to use them in a combine manner rather than using them independently. A Hybrid protocol takes advantages of these protocols and overcomes the disadvantages of both. A popular hybrid protocol is Zone Routing Protocol. As the name implies the whole network is splitted in different zones. For routing inside the zone proactive protocol is used and between the zones reactive protocol is used. Optimization of ZRP using different radius and nodes on NS2 is executed inside the paper. TORA is used as within the nodes and DSDV between the zones. Performance is judged by using PDR as a parameter. This is done to know at which radius and number of nodes the performance of ZRP is the best. ZRP is a not a distinct protocol as it provide framework for other protocols.

KEYWORDS: ZRP, TORA, DSDV, PDR, NS2.

1. INTRODUCTION

Mobile Ad hoc networks are unconventional network of autonomous mobile node connected over wireless link. As network employs mobile node, it does not have any fixed topology and central management. All node work as a router whose primary function is to provide best routed path in a given direction of destination. Several routing protocols have introduces in Adhoc network; proactive, reactive and hybrid routing protocols. In proactive routing protocols, Source sent packet to destination without wait, because routes are already provided by the network. Routing procedure takes two approach; route request and route reply. On the other hand the disadvantage is that it sends route request packet to all the nodes in which a lot of bandwidth is wasted a very used proactive protocol is "TORA" protocol. In reactive protocols the route is maintain on the request of the source node because of this source node has to wait until the route is provided by the network thus source node suffer delay. On the other hand the advantage is that route request is send only to the node to which packet is to be send so bandwidth is utilized very popular reactive protocol is "DSDV" protocol. Hybrid protocol is a combination of both of the protocol most commonly used hybrid protocol is "ZRP".

This paper is divided into 5 parts. In the first part description of ZRP is given with its architecture. A second part tells about the background of ZRP. The third part tells about the proposed work, fourth parts deals with the simulation and result and the fifth part tells about conclusion and future work.

2. ZONE ROUTING PROTOCOL

As the name implies Zone routing protocols is a hybrid protocol in which complete network is dived into zone of radius 'p' that include nodes that are hop count away from each other. The complete protocol is composed of four protocols; IERP, IARP, NDP and BRP. Nodes in the zone are kept as; Nodes with hop count = p are called as peripheral node, nodes with hop count < p are called as exterior node, nodes with hop count > p are called as interior node.

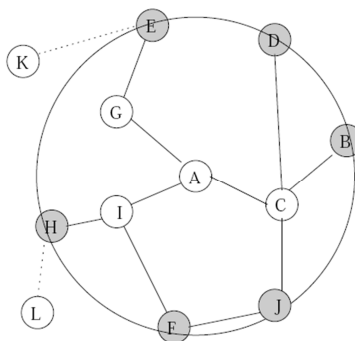

Figure1. Zone of 'A' with radius $p = 2$

In the above example for node 'A', nodes 'C', 'I', 'G' is one hope count away from 'A' and the radius of zone is 2. This means these nodes will stay inside the zone because hope count < p. But nodes B,J,D,E,H,F are two hop count away from 'A' so hope count = p, so all of these nodes will act as peripheral nodes. For nodes 'k', 'L' hope count > p, so these nodes will stay out of the zone.

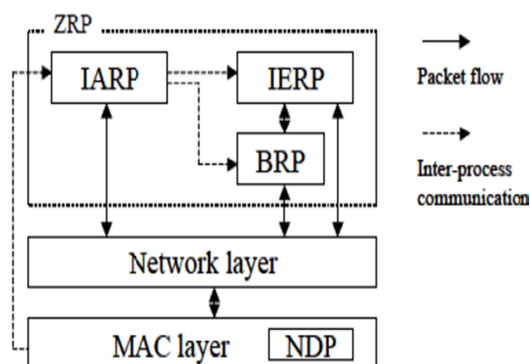

Figure2. Architecture of ZRP

2.1. NDP

Neighbour discovery protocol is used by a node to know about its direct neighbour. This is done by sending 'hello' beacons by source node, node that wants to communicate replies with a response. Once the local routing information is achieved node periodically broadcast discovery message to know up to date information about its neighbour node.

2.2. IARP

Intra zone Routing Protocol provides the possibility of direct neighbour discovery. This protocol helps in determining the routes to the interior nodes to the peripheral nodes and is commonly a proactive protocol. The nodes inside the zone are able to communicate with each other with the help of this protocol.

2.3. IERP

Inter Zone Routing protocol is used to perform routing outside the zone. This is commonly a reactive protocol. This is called as Global discovery protocol. In ZRP if the node has to send packet that is outside the zone first interior node will sent to peripheral node than peripheral node will send it to the other zone where destination node resides rather than flooding packets to all nodes. This process of providing route from the peripheral node to the destination node located inside the other zone is done by IERP.

2.4. BRP

Border cast resolution protocol is used to direct route request by IERP to peripheral node. It keeps track to which nodes query has to be delivered. For the nodes that do not lie in the zone from which query has been received it constructs a border cast tree to pass it to the neighbour node. The node after receiving query packet again constructs the border cast tree to determine whether it belongs to the tree of sending node.

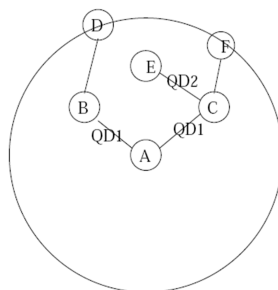

Figure3. Query Detection

Direct query in known as query detection one (QD1) ,when node receive information by listening to traffic broadcast among other node it is known as query detection second (QD2).

In order to eliminate unnecessary broadcasting BRP uses selective border casting. In this approach peripheral nodes that are not in use are removed.

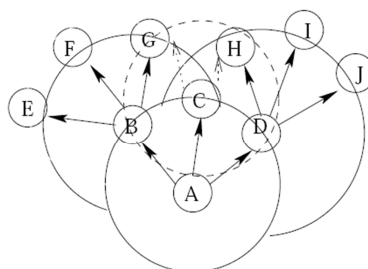

Figure4. Selective Border Casting

In the image it is clear that node C is an unnecessary node it can be removed by A. So the performance of the network can be increased by using selective broadcasting.

3. BACKGROUND

3.1. Sree Ranga Raju, Jitendranath Mungara evaluated the performance of ZRP using Qualnet simulator 4.0. In their paper, they incorporated two new algorithms; to reduce the network load and to optimize the performance of query control mechanism for ZRP in urban terrain. Network load was slim down by limiting the number of control packets when ZRP searches for a new route. . By using these algorithms they defined ZRP as enhanced ZRP and showed that on using these algorithms the enhanced ZRP was superior than that of conventional ZRP.

3.2. Shailendra Kumar Pathak, Raksha Upadhyay, Uma Rathore Bhatt evaluated the performance of ZRP using Qualnet simulator 5.0.2. In their paper an algorithm for controlling the forwarding of query packets has been provided. These query packets are forwarded by the nodes which are the local zone member of that node which has immediately broad casted or forwarded these query packets. Hence by limiting these query packets forwarding inside the local zone of a node minimize the network traffic and load. By using this algorithm there was reduction in control packets so they named ZRP as ZRP1 and compared it with conventional ZRP, the performance of ZRP1 was better than that of ZRP.

3.3. Amit Kumar Jaiswal, Pardeep Singh put forward a routing protocol named Optimizing Velocity Based Adaptive Zone Routing Protocol (OVBAZRP) in their paper. This protocol showed good results in terms of ; Stability and routing performance for situations where mobile nodes move with inconsistent speeds, according to this protocol zones were selected by the nodes according to their speeds and speeds were determined by the strength of the signal received by neighboring nodes. This modified ZRP was superior than that of conventional ZRP..

3.4. Sandeep Kaur, Supreet Kaur in their paper performed the analysis of ZRP by taking different performance using Qualnet simulator 14.0 on 20 40 and 60 nodes. From the results they concluded as the number of node increases high throughput is achieved. On taking a network of 20 nodes load is minimum, but as nodes are increased high load, delay and data drop increases.

4. PROPOSED WORK

The work is to analyse the performance of ZRP on different nodes and radius. Nodes from 0-80 are taken with radius 0-9. Simulation is performed on Network simulator 2.35 and packet delivery ratio is estimated. To determine on how many nodes and at which radius the performance of ZRP is the best. The area is 10000*10000 because for 80 nodes analysis has to be performed. Inside the zone TORA protocol is used and outside the zone DSDV is used. Source nodes is the first node and destination node is the last node for node from 10-80.

Packet Delivery Ratio (PDR) – It is the ratio of the number of packets successfully received by destination nodes to the total number of packets sent by source nodes in network.

$$PDR = \left(\frac{\text{Received packet}}{\text{sent packet}} \right) \times (100)\%$$

5. SIMULATION AND RESULT

Table1. Parameters

Channel Type	Wireless
Radio Propagation Model	Two Way Ground
Antenna Type	Omni Antenna
Packet Size	512 bytes
Nodes	10-80
Data rate	11Mb
Mac Type	802_11
X*Y Area	10000*10000

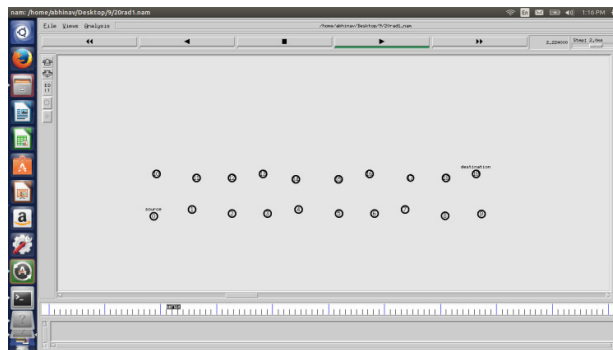

Figure5. NAM Output

Fig 5 is the NAM file of 20 nodes where source is node 0 and destination is 19. After 3-4 seconds various zones builds up that includes node in them. Nodes themselves become peripheral, interior or exterior according to the zone radius.

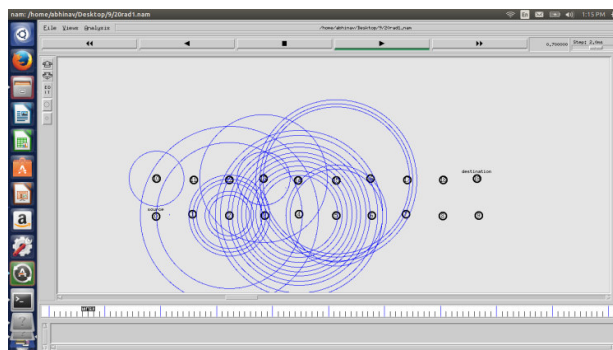

Figure6. NAM Output

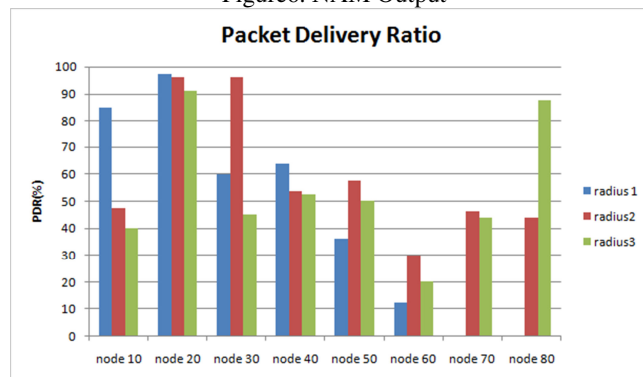

Figure7. Packet Delivery Ratio (Radius 1, 2, 3)

It is clearly visible here that for 20 nodes PDR is maximum at radius 1, 2, 3. Radius 1 can only be used till 60 nodes because after this, it gives least values of PDR. Up till 80 nodes radius 2 and 3 should be chosen for achieving good PDR. So if we want a zone of 20 nodes any radius from 1 up to 3 can be taken or vice versa.

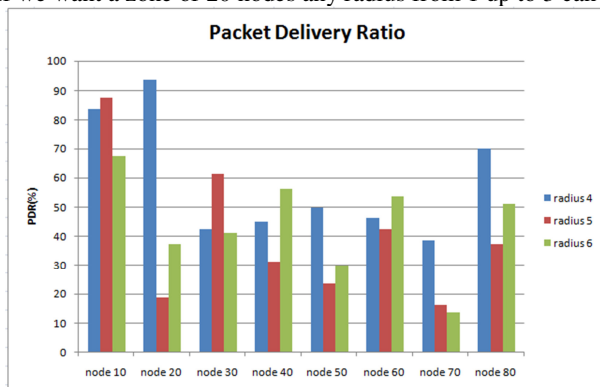

Figure8. Packet Delivery Ratio (Radius- 4, 5, 6)

For 10 nodes the radius 4, 5, 6 are showing good results of PDR. But for 20 nodes at radius 4 PDR is maximum. PDR is average for 30, 40, 50, 60 nodes. For 70 nodes PDR is least and at radius 4 for 80 nodes PDR is also showing good results. For 80 nodes taking radius 4 will also give optimal values of PDR. Radius 6 is only giving good result for 10 nodes, 40 nodes and 80 nodes.

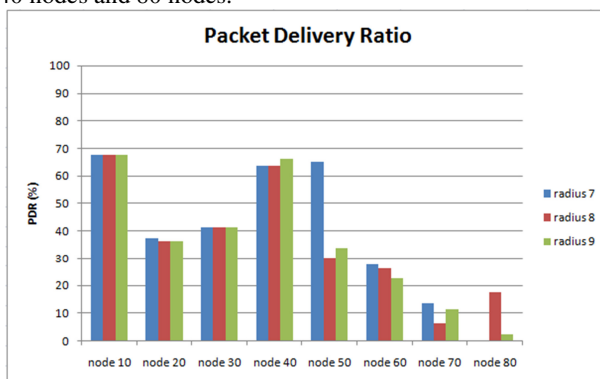

Figure9. Packet Delivery Ratio (Radius 7, 8, 9)

We can see here 10 nodes at radius 7, 8, 9 are again showing optimal results. There is sudden decrement of PDR for 20 nodes. 60, 70 and 80 nodes show bad result of PDR. For nodes 40 and 50 average PDR is achieved. Here we can see as we are increasing number of nodes and radius we get less PDR. We should never take 7, 8, 9 radius if we want a zone of 80 nodes. Radius 7 is showing fine results for 10, 40, 50 nodes.

So we can conclude now that for 10 nodes radius 1, 4, 5, 6, 7, 8, 9 can be taken for good PDR. This means 10 nodes show good result in ZRP. For 20 nodes radius 1, 2, 3, 4 should be taken this gives excellent PDR. For 30 nodes radius 2 gives excellent PDR and radius 4 gives average PDR. For 40 nodes radius 1, 6, 7, 8, 9 can be taken for average PDR. For 50 nodes in ZRP radius 7 should be taken for good PDR. For 60 nodes only radius 6 should be taken. For 70 nodes only radius 1 gives normal PDR. For 80 nodes radius 3 & 4 gives good PDR.

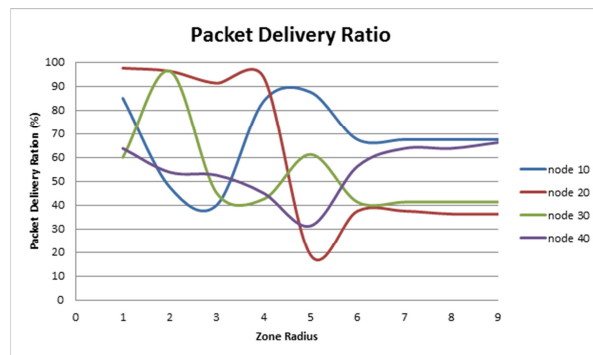

Figure10. Packet Delivery Ratio Relative Analysis

It can be said now for 20 nodes good values of PDR is achieved but decrease thereafter, while at 10 nodes maintains constant performance increases with increase zone radius(except radius 2 &3)

6. CONCLUSION & FUTURE SCOPE

In this paper the optimization of ZRP has been performed by taking different radius and different nodes. It can be stated that 20 nodes are best for radius 1, 2, 3. Radius 4, 5, 6 gives average values for 30-80 nodes and good values are only achieved at radius 4 for nodes 10, 20 and 80. Nodes from 40-70 shows varying performance as radius is increased or decreased. Still 40 nodes give good PDR at radius 7, 8, 9 and 50 nodes at radius 7 only. So for radius raising 1-3, 20 nodes should be taken and vice-versa. For radius 4-6, 10 nodes should be taken and for radius 4 again 20 nodes are good and 80 nodes. For radius 7-9 only 10 nodes or 40 nodes should be taken. In future the performance can be judged by taking more than 100 nodes in the network with changing position on source and destination at different time.

REFERENCES

- [1] Sree Ranga Raju and Kiran Runkana and Jitendranath Mungara, "Performance Measurement and Analysis of ZRP for MANET's Using Network Simulator-QualNet" 2010 IEEE
- [2] Sree Ranga Raju and Jitendranath Mungara, "A Unified Approach to Enhance the Performance of ZRP for MANETs on an Urban Terrain" 2010 IEEE.
- [3] Amit Kumar Jaiswal and Pardeep Singh, "Optimizing Velocity Based Adaptive Zone Routing Protocol" Int'l Conf. on Computer & Communication Technology 2010 IEEE pg. 149-152.
- [4] Z. Shafiq and S. A. Mahmud and G. M. Khan, A Sayyed and H. S. Al-Raweshidy, "Zone Routing Protocol: How does it Perform the Other way Round" 2012 IEEE ICTC pg 71-77.
- [5] Vishal A. Polara and Jwalant B. Baria, "Analyzing Performance of ZRP by Varying Node Density and Transmission Range" 2013 IISTE PG 21-31.
- [6] Sandeep Kaur and Supreet Kaur, "ANALYSIS OF ZONE ROUTING PROTOCOL IN MANET" 2013 IJRET pg. 520-524..
- [7] Shailendra Kumar Pathak and Raksha Upadhyay and Uma Rathore Bhatt, "An Efficient Query Packets Forward Algorithm in ZRP Protocol" 2014 IEEE ICICT pg 592-595.
- [8] Kanishka Raheja and Sunil Kr Maakar, "A Survey on Various Enhancements Made on ZRP" International Journal of Computer Applications 2014 pg.42-45.
- [9] Hema Rani and Pooja Nagpal, "Performance Analysis of Enhanced Zone Routing Protocol (EZRP) in Mobile Ad Hoc Network" 2014 IJSRD pg. 467-470.