

# Position Control of Linkage Underactuated Robotic Hand

Shaker S.Hasan<sup>1</sup> Somer M. Nacy<sup>2</sup> Eldaw E. Eldukhri<sup>3</sup> Haider Galil Kamil<sup>3</sup> Enass H. Flaiech<sup>1</sup>  
Mechanical Engineering Department , University of Technology, Baghdad<sup>1</sup>  
Biomedical Engineering Department, Al-Khwarizmi College of Engineering, University of Baghdad<sup>2</sup>  
Institute of mechanical and Manufacturing Engineering School of Engineering, Cardiff University<sup>3</sup>

## Abstract

In this study a proposed PID control system for (Ca.U.M.Ha) robotic hand with a finger and a thumb introduced, to control grasping cylindrical objects made from different materials soft and hard within a range of (48-150) mm in diameter . A samples of PID response figures for object that need just a finger, and object that needs a finger with a thumb introduced in additional to the figures of actuators voltage needed for both cases through grasping.

**Keywords:** Linkage , underactuated, position PID control

## 1. Introduction.

The under actuation term is widely used in Robotics manipulators. This shows a powerful ability for grasping objects and has the capability of adapting its shape to envelop different grasped objects even if the robotic finger is controlled by less number of actuators, than its degrees of freedom, and with simple control, low cost and easy operation. The underactuated robotic hands were introduced as simple type of dexterous hands. PID control system design area have mainly two approaches, the empirical method, and the analytical method .In the empirical method, the controller design relies heavily on past experience and on repeated experiments ,although the empirical method (guess and check) must be carried out by trial and error, it may be used successfully to design some physical systems .This method is inadequate if there is no past experience to draw from ,or if experimentation is not feasible due to high cost or risk. The analytical method needs an adequate formulation of the equations of the system. The PID controller calculates the error value as difference between the measured variable and the desired set point .It attempts to minimize the error by adjusting the process, using a manipulated variable. The controller algorithm consists of three separate constant parameters and accordingly, usually called three-term control: the proportional, the integral and derivative terms.

## 2.Literature Review

Lionel Birglen and Cle'ment M.Gosselin ( 2005) proposed a control scheme for MARS robotic hand. The researchers introduced a control scheme dedicated to under-actuated fingers by using tactile sensors. A real time control was introduced based on fuzzy force control and slippage prevention was also presented. Preliminary experiments were conducted in force control to ensure that the grasping force can be controlled using tactile feedback .Their experimental results by PID controller proved to be very disappointing. Then a fuzzy logic approach was adopted by increasing or decreasing the actuator torque until objective contact force was attained. Since the contact forces are highly sensitive functions of the joint angles of the finger and contact locations on the phalanges, the input of the fuzzy controller was the contact force error, while its output was the actuator torque variation. Initial experiments showed that these rules were not sufficient since the contact force tend to oscillate around the desired input. To solve this problem another fuzzy input was added. Amir Fassih et al.( 2012) aimed in his research by exploiting the main properties of under-actuation to perform motion tasks close to reference angles obtained by EMG signals . The proposed control law was a modified version of the standard PD control in the joint space adding the gravity compensation term, by considering the position error defined as the difference between the reference set point and the current joint angle that based on results of optimal design a model of two phalanx fingers was made by ADAMS. A multi-body dynamics modeling software was linked with matlab and Simulink software to implement the controller. N.Z.Azlan and H.Yamaura (2011) proposed a position control of a light weight and small size linkage robotic finger during non-contact motion. The finger had a fingertip pinching and self-adaptive capabilities .The PID controller was chosen where the controller input to the motors was the voltage signal covered by the PID controller. The error in the controller was the difference between the reference and the actual angular displacement of the actuated link .The RLS (Recursive least square) based FEL (Feedback Error Learning) was implemented to overcome any parameter uncertainties presented in the plant. The feedback loops were to ensure the stability of the whole system and acted as the learning signal for the forward loop. The experiment results showed that PI control scheme was efficient in controlling the slider movements. Da-peng Yang et al. ( 2010)proposed a control system of HIT/DLR Hand which composed of five-finger prosthetic hand and three active DOF's .Three motors were used ,one for the thumb, the other for index finger and the last for the rest three fingers together. The hand was implemented on two boards, one was the motor control board ,implementing the motion control of prosthetic hand ,while the other board was EMG for

high level control implementing the recognizing of hand's motion .The motor control board was based on(DSP)(digital signal processor),and a motor drive chip to implement the corresponding motion control of multi finger position control and force control of finger for position control of the finger base joint .The researcher proposed a classical PID- controller to reduce the error between actual and desired base joint of the finger. Pierluigi Rea (2011) used a closed-loop pressure control system through PWM modulated pneumatic digital valves . He designed and experimentally tested this controller ,in order to determine and analyze the static and dynamic performances of Ca.U.M.Ha robotic hand .The proposed and tested closed-loop control system was applied to the robotic hand to control the actuating force of the pneumatic cylinders of articulated fingers .The PWM modulated control signal was generated via LabView software .A typical PID compensation of the error between the input electric signal and the feed-back electric signal was carried out through a PC controller. Electric switches were installed on the palm in order to detect the eventual fully closed configuration of each proximal phalanx.

### 3. Robotic hand description

The under actuated finger mechanism of (Cassino –Underactuated –Multifinger-Hand) Ca.U.M.Ha were adopted by changing the orientation of hand in a way that the new hand will take account of the weight of the grasped object. Torsional springs were mounted in the second and third joints to perform a determined motion. The torsional springs have  $D_o=9.3\text{mm}$ ,  $D_{in}=7.68\text{mm}$  and number of turns=4.They are fixed in a way that they will work with the motors direction in grasping task and reversing the motor in releasing objects, in a way that it will simulate the human hand. This will help to adapt the objects with different geometries especially in power cylindrical grasping that had been chosen to perform. The implemented robotic hand is composed of a DC linear actuator that accelerates the finger in both directions. The slider –crank mechanism which translates the linear motion of the slider into rotation motion. It will accelerate the first four bar linkage to move which stands for the transmission mechanism that will move the first phalanx of the finger, then moves the second four bar linkage that will move the second phalanx and finally the third phalanx which represent the output link of the second four bar linkage. The thumb is moved by another linear actuator through a hinge joint. In this joint, an angular potentiometer was mounted to measure the thumb joint through movement as shown in figure (1).

### 4. Control

PID controller calculates the error value as difference between the measured variable and the desired set point .It attempts to minimize the error by adjusting the process, using a manipulated variable. The controller algorithm consists of three separate constant parameters and accordingly, usually called three-term control: the proportional, the integral and derivative terms figure (2). The linear actuators used in this investigation are DC motors that have been geared to extend and contract an arm rather than rotate a shaft used in applications that recommend precise position control. The PID controller algorithm used in feedback loop to regulate the linear actuator position (Ogata, 2012)is described by the equation:

$$u(t) = K_p er(t) + K_i \int_0^t er(\tau) d\tau + K_d \frac{d}{dt} er(t) \quad (1)$$

Where:

$u(t)$ : The controller output variable.

$k_p$  : Proportional gain, a tuning parameter.

$k_i$  : Integral gain, a tuning parameter.

$k_d$  : Derivative gain, a tuning parameter.

$er$  : error=  $y_{sp} - y$  t: The present time or instantaneous time

$\tau$ : Variable of integration, takes on values from time zero to the present (t).

$y_{sp}$ : The set point

$y$ : Measured process variable

### 5. Experimental set up

The experimental set up for the robotic hand control system is illustrated in figure (3).It consists of a PC target system, voltmeter, power supply and a box having a power amplifier .The PC is installed with a DAQ-2501 acquisition board . It reads the signals from the potentiometers of linear actuators of both the finger and the thumb. It provides the output control signals to the DC linear actuators based on the pre-training conditions for the objects with their different diameters, weights and materials through the DAQ board .Since the output current from the DAQ board is limited to low current, it is not enough to drive the motors, therefore an a power amplifier is used to amplify the power for operating the motors according to the equation ( $P=V*I$ ) without any change in voltage. The DC motor is geared with 20:1 with a screw and a nut to perform the linear actuator. The motor is equipped with a potentiometer of 10Kohm to measure the linear position of the linear actuator and

determines the position of the slider, and that moves the finger. The C++ program is chosen to execute the control commands to derive the robotic hand mechanism, since it is easy to implement. The figure (4), describes the block diagram of the experimental apparatus. Referring to figure (4), let  $y$  be the output measured process value, which represents the instantaneous value of slider position,  $u$  is the control signal which is the potentiometer voltage that stand for the slider distance and ( $e_r$ ) is the control error ( $e_r = y_{sp} - y$ ). The reference variable ( $y_{sp}$ ) is often called the set point that represents the potentiometer voltage obtained for each grasped object calculated from the primarily experiments through training of the robotic hand to grasp each object. This method followed to grasp different cylindrical objects as shown in figures (5) and (6).

## 6. Experimental process

Before performing the grasping task, the object geometry should be determined and the hand should adjust itself to this geometry by orienting the Finger, with the thumb, in the case where the cylindrical objects diameter is greater than 90 mm according to the hand design specifications. To orient the finger, a simple trajectory is generated to a prescribed slider position and the linear actuator should follow this trajectory with the PID position control, when the grasp is to be performed, a closing trajectory is generated up to a fully closed position. The position of the motors is obtained from the potentiometers attached to the linear actuators. The objective of the experimentation is to confirm the variety of sizes of objects that can be successfully grasped by this hand also, the characterization of this hand and the experimental validation of the control scheme are important issues. In order to test the adaptability of the hand, a wide range of cylindrical objects of different materials were grasped. Each object at first was placed manually in the hand to be grasped, and turned on the motor is to accelerate the hand mechanism until it grasps the object stably, to show the hand configuration which meets specific slider distance representing specific voltage reading of potentiometers of both linear actuator of the finger, and the thumb actuator, if it was needed. This method is followed for all selected different objects. The objects are grasped again, but this time by the suggested control system by performing the PID control algorithm (Oualline, 1997). According to the control strategy, the control algorithm will ask about the object that the hand should grasp, the grasping information that include the potentiometers voltages were already predetermined by the primly training of the hand of that object. The PID controller calculates the error value, the difference between the present measured variable that represents the potentiometer voltage readings for both the fingers and the thumb, and the desired set point that represent the potentiometers readings values recorded in the primarily experiments. For each object, the controller minimizes the error by adjusting the three constant parameters, the proportional term ( $K_p$ ), the integral term ( $K_i$ ), and the derivative term ( $K_d$ ). This control strategy test the grasping of different objects of different diameters, the minimum cylindrical object the hand could grasp is (48mm) up to (150mm) in diameter. The control signal is the sum of the three terms, figure (2),  $K_p$ -term which is proportional to the error,  $K_d$ -term which is proportional to the derivative of the error, and  $K_i$ -term which proportional to the integral of the error.  $K_p$  depends on the present error,  $K_i$ , on the accumulation of past errors, and  $K_d$ , is a prediction of future errors, based on the current rate of the change. This control loop will allow the linear actuator to move to a precise required position and remain there even if an external force tries to move it. The goal of the control loop to use data from the feedback device (the potentiometer) to iteratively adjust the output until it has reached the target measured value.

## 7. Results and Discussion

It was noticed, from the potentiometers reading figures through, grasping different objects, these readings represent the outputs of the control system from PID control system. The figures (7),(10) show a good response of the system according to the good choice of the PID controller parameters by studying the historical movement of the hand where the position control was adopted through grasping objects as indicated before, where figure (7) shows the PID control response for the output signal through grasping object (A), which need just a finger to be grasped. Figure(8), shows the slider distance through grasping object (A), while figure (9) shows the voltage taken by the finger actuator through grasping the same object. Figure(10) shows the finger potentiometer through grasping object (G), which need a finger and a thumb to be grasped as its diameter 90 mm, while figure (11), shows the slider distance through grasping the object, while figure (12) shows the finger motor voltage needed through grasping the same object. Figures (13) and (15) represent the thumb potentiometer voltage and the thumb rotation respectively. Figure (14) shows the thumb motor behavior through grasping the object (G). The way to grasp the object by a finger and a thumb, the finger will move to some specified configuration that's by moving the slider to defined distance, then the thumb will move to a predefined position, and finally the finger will move again to enclosed the object stably. That the position and time the finger ends, the thumb start to move as shows in different figures for finger and thumb potentiometers and in finger and thumb actuators, while all actuators voltage shows that, the actuator starts with the maximum voltage which is 10 v, then that value decreases gradually as the finger reaches the predefined configuration for the specific grasped

object which is represented by the potentiometers values that stand for the slider distance ,the decreasing in voltage taken by the actuators leads to decreasing in actuator speed avoiding to hit or crash the grasped object .The other grasped object follow the same behavior as object (A),for objects need just a finger to be hold ,while object (G),considered as a sample for objects needs a finger and a thumb to be grasped.

## References

- Azlan, N. Z., & Yamaura, H. (2011). Experimental Studies of Position Control of Linkage based Robotic Finger. *World Academy of Science ,Engineering and Technology*, 5(58), 426–432. Retrieved from <http://waset.org/publications/3733/experimental-studies-of-position-control-of-linkage-based-robotic-finger>
- Birglen, L., & Gosselin, C. M. (2005). Fuzzy enhanced control of an underactuated finger using tactile and position sensors. In *Proceedings - IEEE International Conference on Robotics and Automation* (Vol. 2005, pp. 2320–2325). doi:10.1109/ROBOT.2005.1570459
- Fassih, A., Subbaram Naidu, D., Chiu, S., & Kumar, P. (2012). Design and control of an underactuated Prosthetic hand. In T. Kambe, C. Aida Bulucea, & C. Ara Patsakos (Eds.), *ACA'12 Proceedings of the 11th international conference on Applications of Electrical and Computer Engineering* (pp. 77–82). Wisconsin, USA. Retrieved from <http://www.wseas.us/e-library/conferences/2012/Vouliagmeni/ACA/ACA-11.pdf>
- Hai, H., Li, J., Yong-jie, P., Shi-cai, S., Qi-rong, T., Da-peng, Y., & Hong, L. (2010). Observer-Based Dynamic Control of an Underactuated Hand. *Advanced Robotics*. doi:10.1163/016918609X12586151361812
- Ogata, K. (2012). *Modern Control Engineering*. (A. Gilfillan, Ed.) (fifth.). New Jersey: Pearson Education, Inc. Retrieved from [http://www.petronet.ir/documents/10180/2323242/Modern\\_Control\\_Engineering](http://www.petronet.ir/documents/10180/2323242/Modern_Control_Engineering)
- Oualline, S. (1997). *Practical C++ Programming*. (A. Nye & D. Dougherty, Eds.) (first.). United States of America: O'Reilly & Associates ,Inc. Retrieved from [http://www.dsi.fceia.unr.edu.ar/downloads/informatica/info\\_II/c++.../Practical\\_C++\\_Programming\\_1995.pdf](http://www.dsi.fceia.unr.edu.ar/downloads/informatica/info_II/c++.../Practical_C++_Programming_1995.pdf)
- Rea, P. (2011). On the design of underactuated finger Mechanisms fo robotic Hands. In H. M. Alfaro (Ed.), *Advances in Mechatronics*. doi:10.5772/875

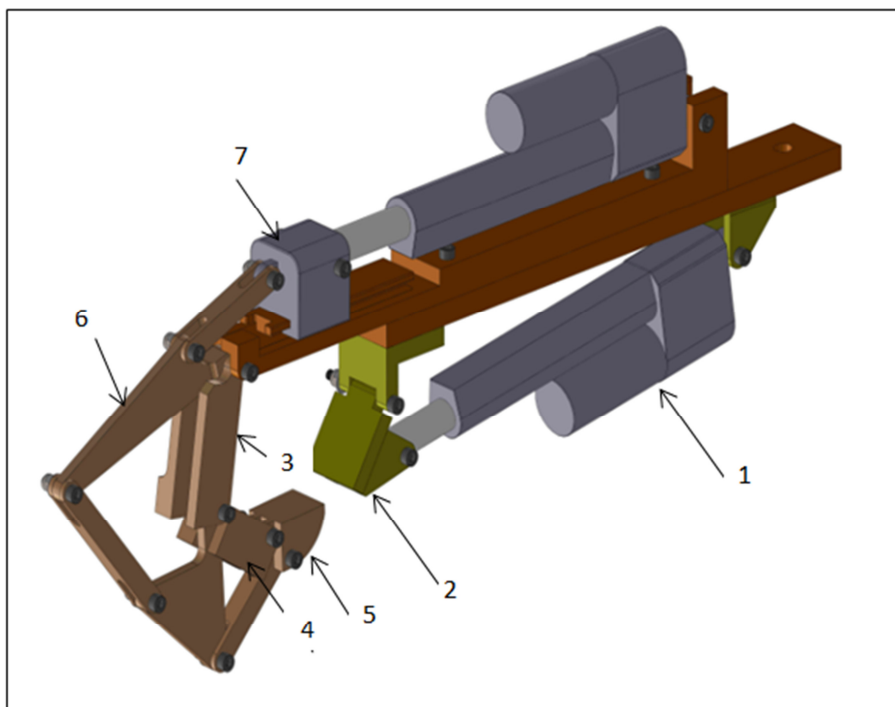

**Fig. (1) 3D model of the hand; 1) Linear actuator 2) Thumb 3) proximal phalanx, 4) Middle phalanx, 5) Distal phalanx, 6) Transmission mechanism, 7) Slider, 8) Base.**

**Table (1) Parameter values of PID controller**

Parameter	value
Proportional constant ( $K_p$ )	15
Integral constant ( $K_i$ )	0.0034
Derivative constant ( $K_d$ )	0.02

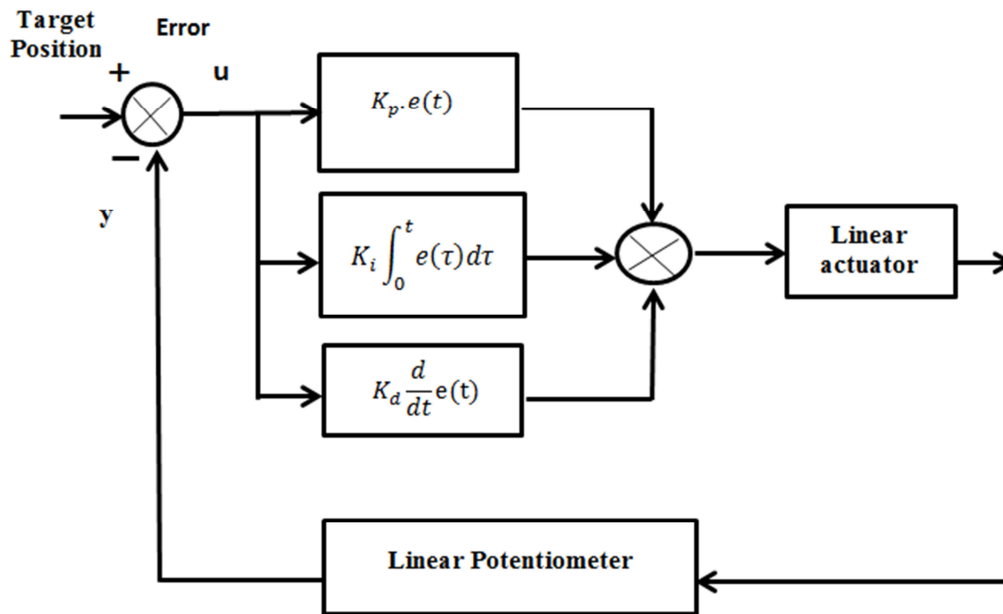

**Figure (2) Flow chart of control process.**

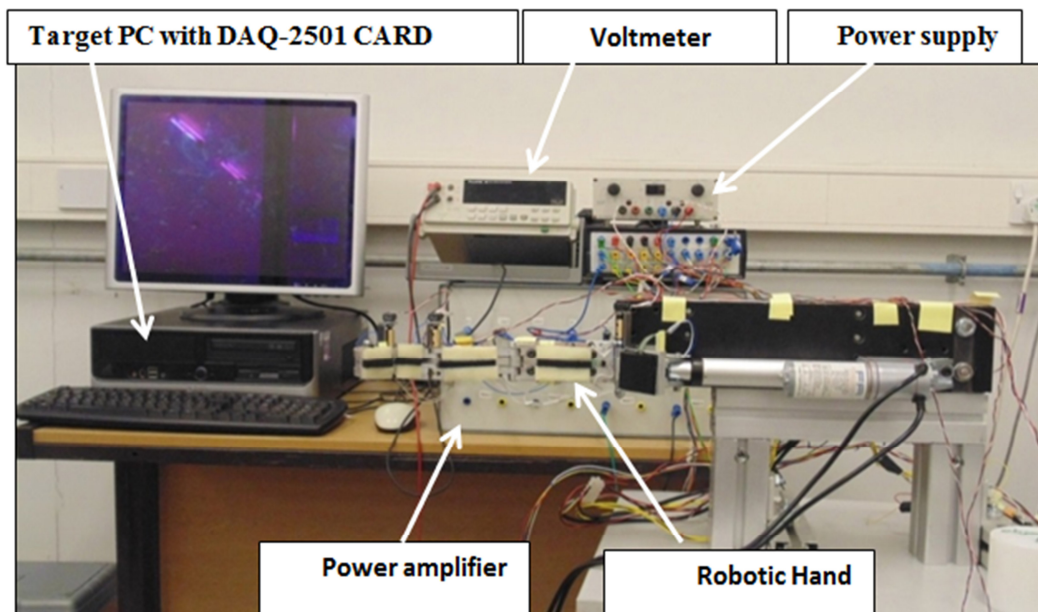

**Fig. (3) Hardware setup**

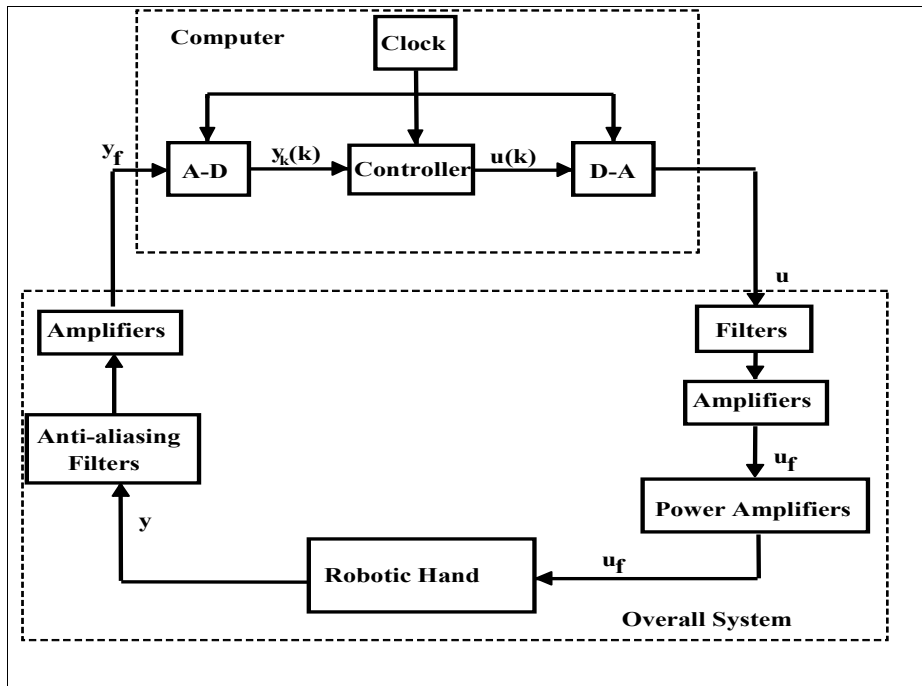
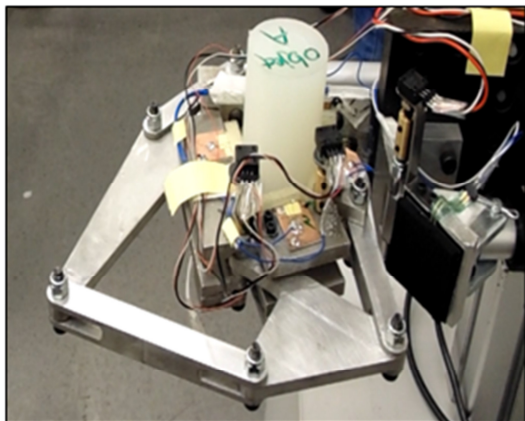
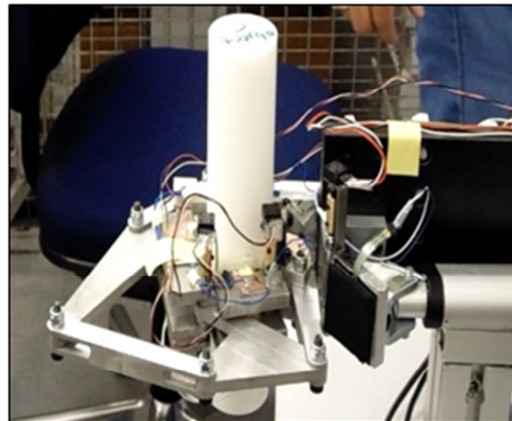

Fig. (4) Block diagram representation of experimental apparatus



a) Object (A), D=48mm, M=0.148Kg



b) Object (C), D=50mm, M=0.631Kg

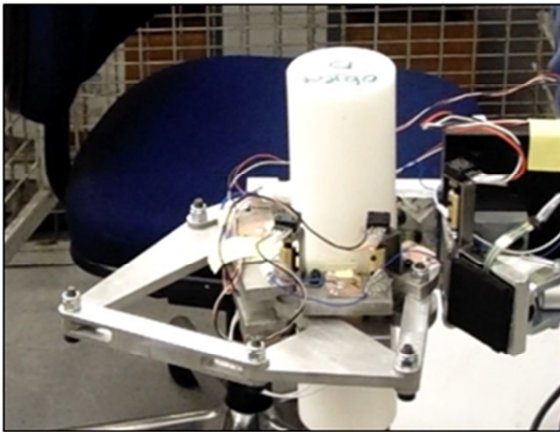

c) Object (D),  $D=60\text{mm}$ ,  $M=0.88\text{Kg}$

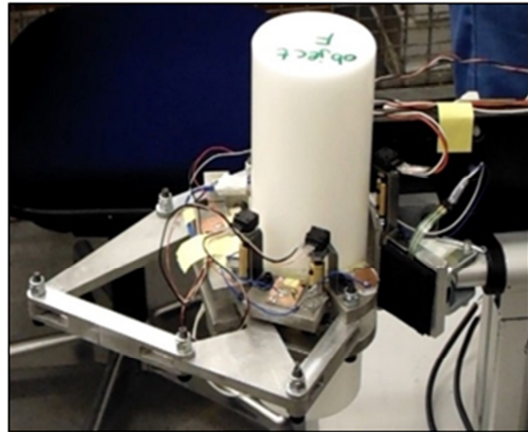

d) Object (F),  $D=80\text{mm}$ ,  $M=1.596\text{Kg}$

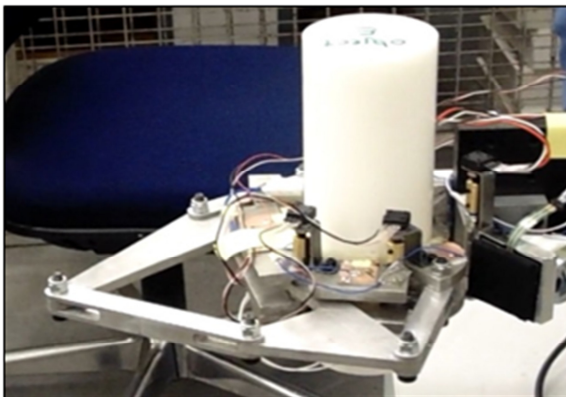

e) Object (E),  $D=70\text{mm}$ ,  $M=1.19\text{Kg}$

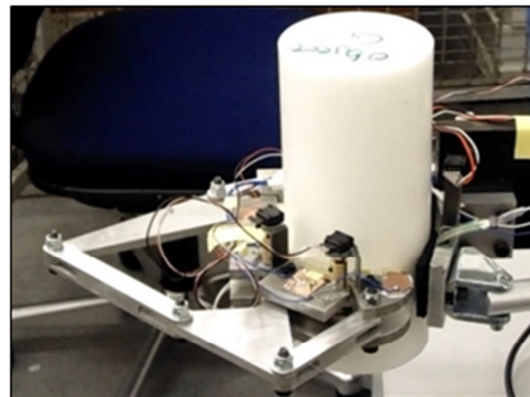

f) Object (G),  $D=90\text{mm}$ ,  $M=2.027\text{Kg}$

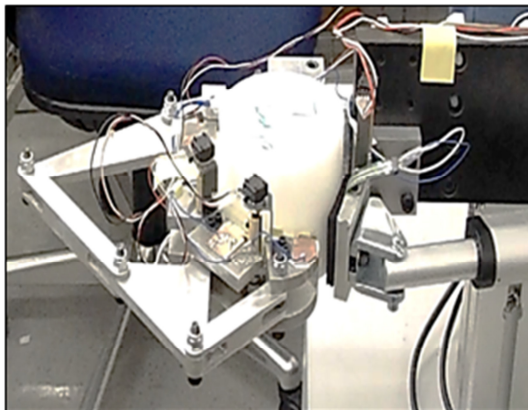

g) Object (L),  $D=90\text{mm}$ ,  $M=0.672\text{Kg}$

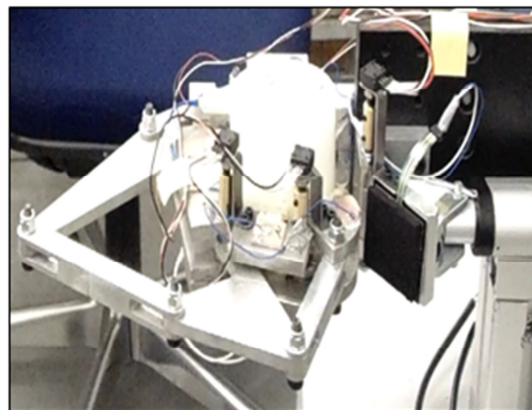

h) Object (J),  $D=70\text{mm}$ ,  $M=0.405\text{Kg}$

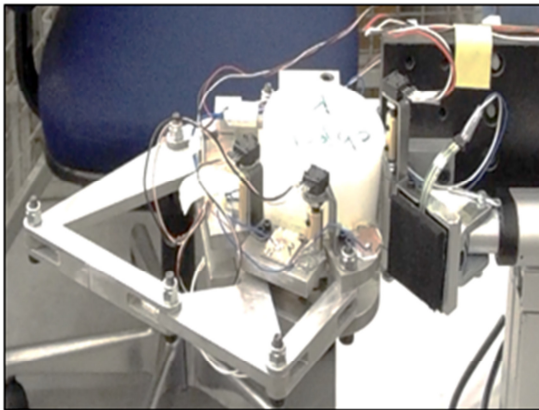

i) Object (K),  $D=80\text{mm}$ ,  $M=0.525\text{Kg}$

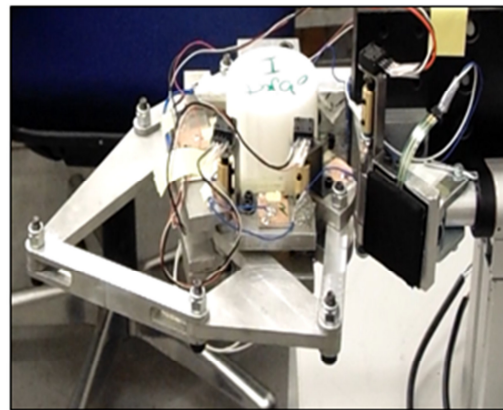

j) Object (I),  $D=60\text{mm}$ ,  $M=0.293\text{Kg}$

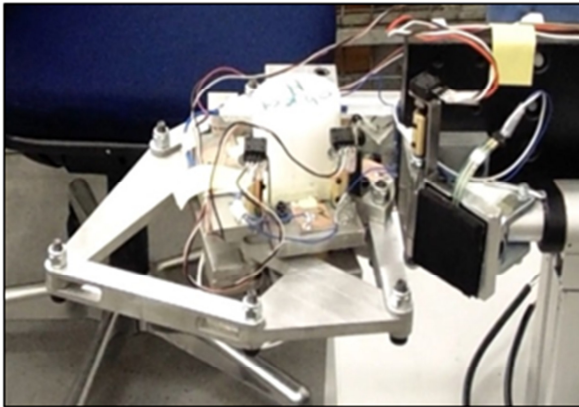

k) Object (H),  $D=50\text{mm}$ ,  $M=0.202\text{Kg}$

**Fig. (5) Grasping cylindrical objects with diameter  $D=48\text{mm}$  to  $90\text{mm}$ .**

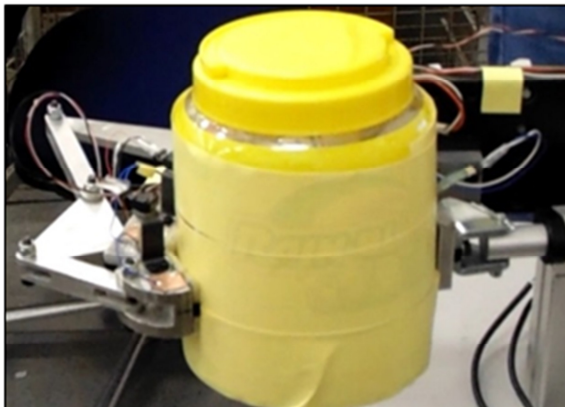

l) Object ( $P_2$ ),  $D=150\text{mm}$ ,  $M=0.159\text{Kg}$

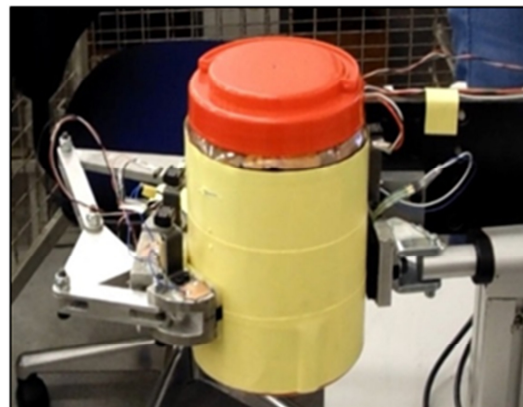

m) Object ( $P_1$ ),  $D=130\text{mm}$ ,  $M=0.155\text{Kg}$



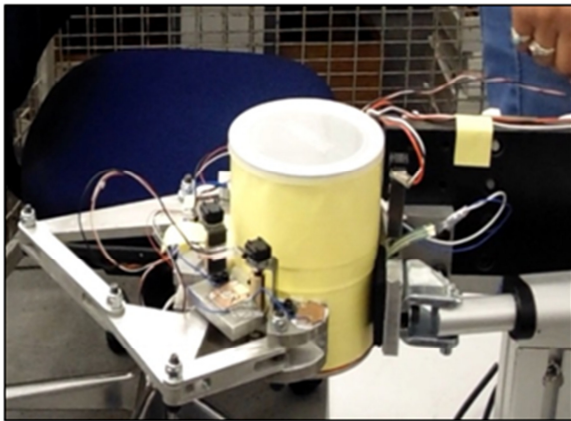

n) Object (M), D=100mm, M=0.1Kg

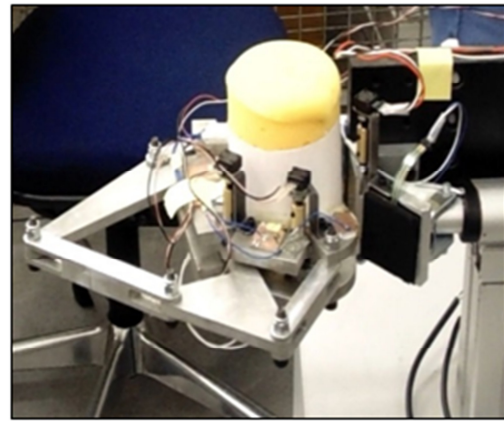

o) Object(S), D=80.5mm, M=0.023Kg

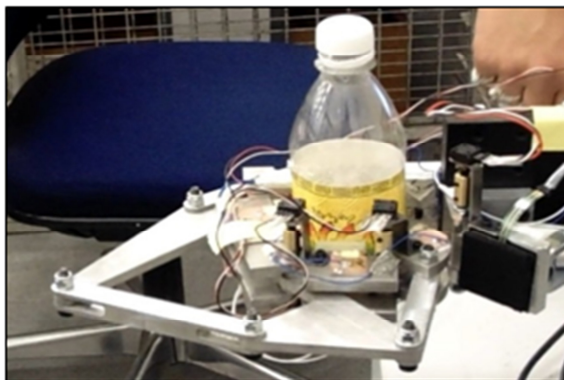

P) Object (P<sub>3</sub>), D=65mm, M=0.555Kg

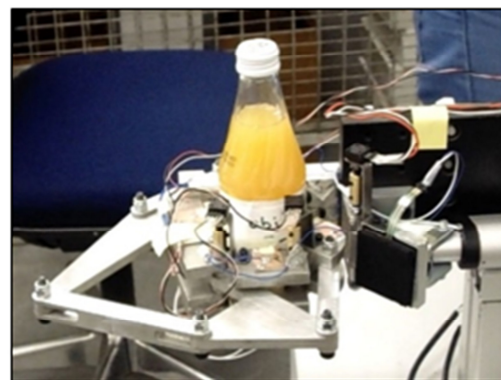

q) Object (g), D=60mm, M=0.745Kg

Fig. (6) Grasping cylindrical objects with different materials.

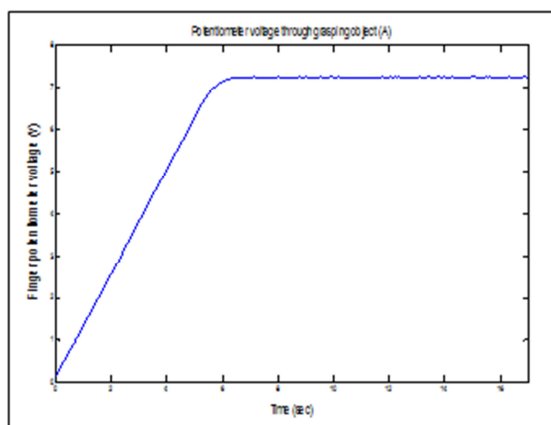

Fig.(7) Finger potentiometer through grasping object (A)

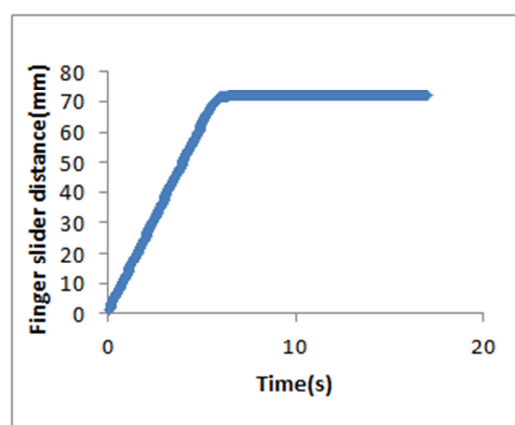

Fig.(8)Potentiometer slider distance for object (A)

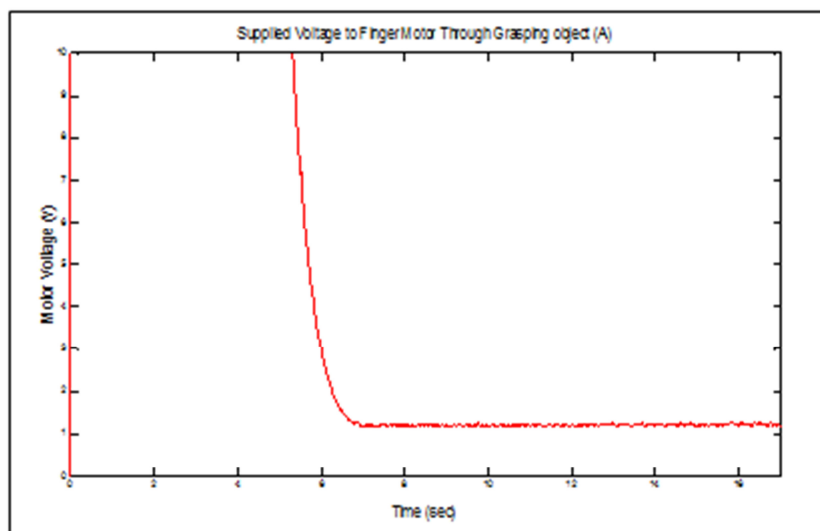

Fig.(9)Finger motor behavior through grasping object (A)

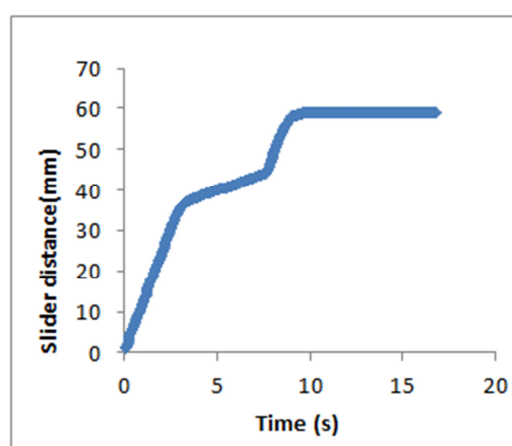
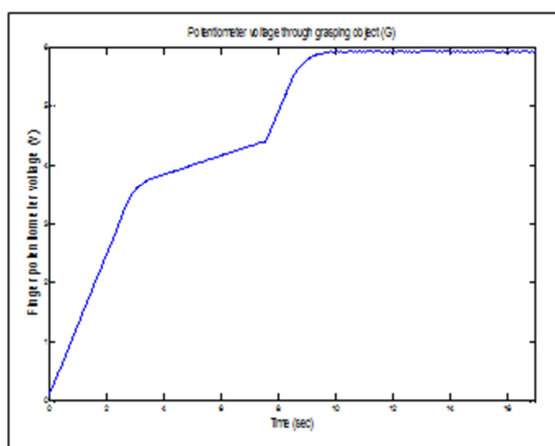

Fig.(10)Finger potentiometer through grasping object (G)

Fig.(11)Potentiometer slider distance for object (G)

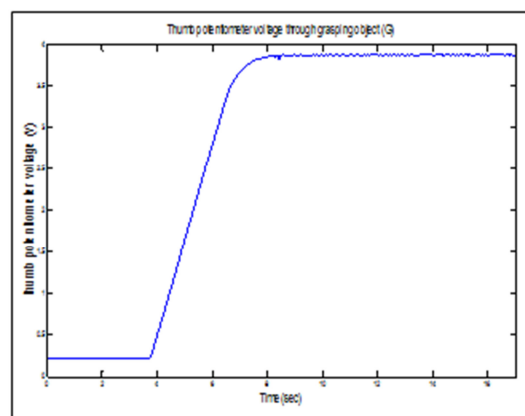
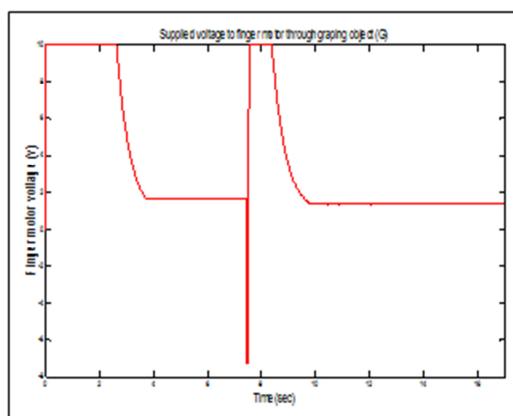

Fig.(12)Finger motor voltage through grasping object (G)

Fig.(13)Thumb potentiometer through grasping object (G)

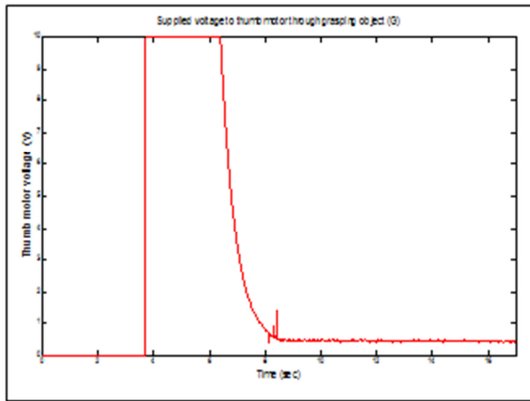

Fig.(14)Thumb motor voltage through grasping object (G)

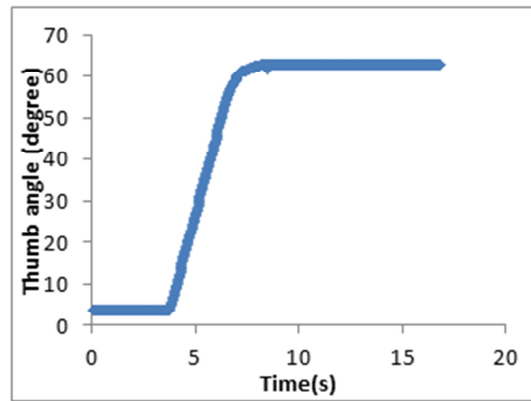

Fig.(15)Thumb rotation through grasping object (G)

The IISTE is a pioneer in the Open-Access hosting service and academic event management. The aim of the firm is Accelerating Global Knowledge Sharing.

More information about the firm can be found on the homepage:

<http://www.iiste.org>

### CALL FOR JOURNAL PAPERS

There are more than 30 peer-reviewed academic journals hosted under the hosting platform.

**Prospective authors of journals can find the submission instruction on the following page:** <http://www.iiste.org/journals/> All the journals articles are available online to the readers all over the world without financial, legal, or technical barriers other than those inseparable from gaining access to the internet itself. Paper version of the journals is also available upon request of readers and authors.

### MORE RESOURCES

Book publication information: <http://www.iiste.org/book/>

Academic conference: <http://www.iiste.org/conference/upcoming-conferences-call-for-paper/>

### IISTE Knowledge Sharing Partners

EBSCO, Index Copernicus, Ulrich's Periodicals Directory, JournalTOCS, PKP Open Archives Harvester, Bielefeld Academic Search Engine, Elektronische Zeitschriftenbibliothek EZB, Open J-Gate, OCLC WorldCat, Universe Digital Library, NewJour, Google Scholar

