

Technical Disclosure Commons

Defensive Publications Series

May 24, 2019

Guide pin holes for blind mating of connectors

Kiavash Faraji

Gordon Chan

Follow this and additional works at: https://www.tdcommons.org/dpubs_series

Recommended Citation

Faraji, Kiavash and Chan, Gordon, "Guide pin holes for blind mating of connectors", Technical Disclosure Commons, (May 24, 2019)
https://www.tdcommons.org/dpubs_series/2219



This work is licensed under a [Creative Commons Attribution 4.0 License](https://creativecommons.org/licenses/by/4.0/).

This Article is brought to you for free and open access by Technical Disclosure Commons. It has been accepted for inclusion in Defensive Publications Series by an authorized administrator of Technical Disclosure Commons.

Guide pin holes for blind mating of connectors

ABSTRACT

Portable electronics have a charging port to which a user can connect a power cable. In situations where a large number of devices are being charged, e.g., at airports, schools, etc., a clutch of cables forms near the charging station that causes visual clutter and inconvenience. Some devices have a female charging port that can be mated with a male charger without a cable, e.g., by visually aligning the male and female connectors before mating. However, when a user is visually impaired, or where there are several simultaneous devices being charged, the mating of connectors is a difficult task that can cause frustration and connector damage. This disclosure describes techniques that place a guide pin hole next to the charging port of a device. The charger has a male element that fits into the guide pin hole. The guide pin hole makes it convenient to slide a device into a charger.

KEYWORDS

- USB-C
- Charger
- Guide pin
- Charging cart
- Charging station
- Blind mating
- Charging rack
- Adapter head

BACKGROUND

Portable electronics have a charging port to which a user can connect a power cable. In situations where a large number of devices are being charged, e.g., at airports, schools, etc., a clutch of cables forms near the charging station that causes visual clutter and inconvenience. Some devices have a female charging port that can be mated with a male charger without a cable, e.g., by visually aligning the male and female connectors before mating. However, when a user is visually impaired, or where there are several simultaneous devices being charged, the mating of connectors is a difficult task that can cause frustration and connector damage.

DESCRIPTION

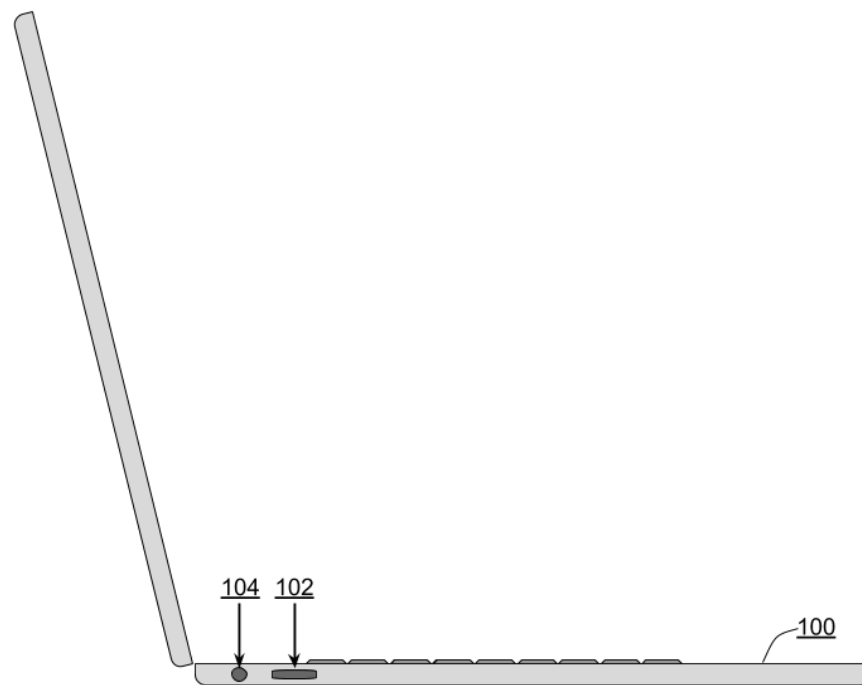

Fig. 1: Guide pin hole on device to enable convenient mating of charging port to charger

Fig. 1 illustrates the placement of a guide pin hole on a device to enable convenient mating of the device to a charger, per techniques of this disclosure. A device (100) that has an expansion or charging port (102) is to be charged. The charging port can be of any type, e.g.,

barrel, USB-A, USB-B, USB-C, mini-USB, micro-USB, etc. The device illustrated in the figure is a laptop; however, the described techniques are applicable to any electronic device, e.g., tablet, smartphone, etc. Per the techniques of this disclosure, a guide pin hole (104) is placed next to the charging port. In some devices, the guide pin hole can be the same as the security slot, e.g., a laptop lock hole, on the device. In some cases, The guide pin hole can be on an attachment that is placed near the charging port of the device.

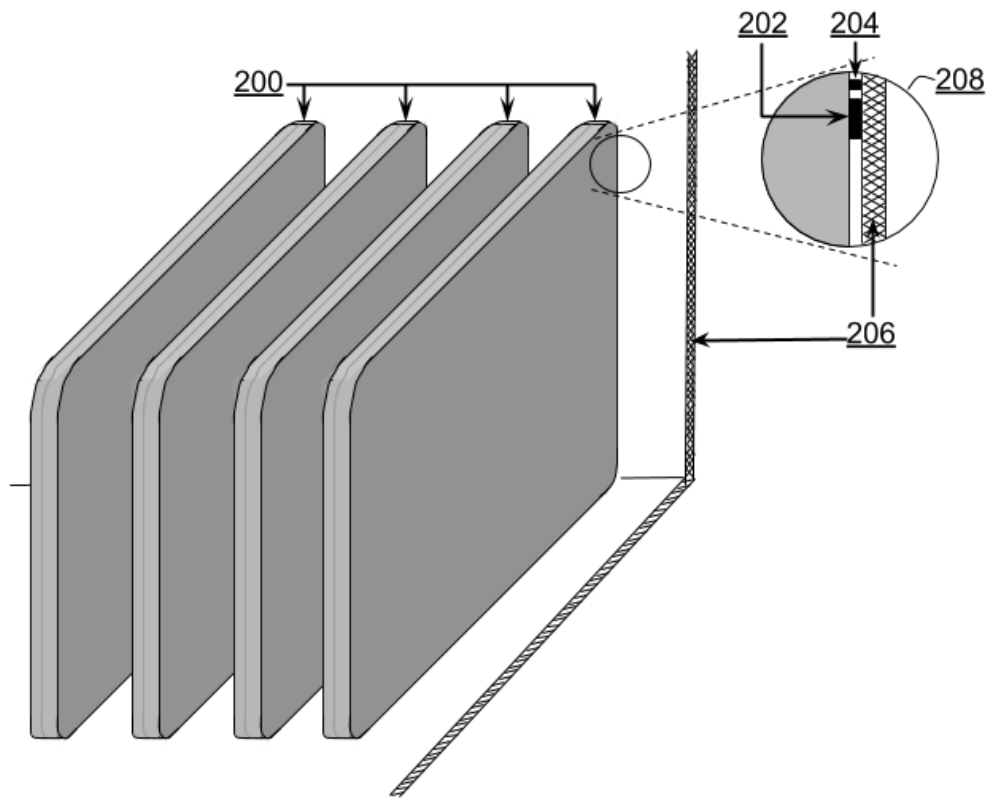

Fig. 2: Devices begin charged on a charging cart

Fig. 2 illustrates a number of devices (200) being charged using chargers located on a wall (206) or on a charging cart, rack, or station, per the techniques. A magnified view (208) is shown of the mating of the female connector on a device and the male connector on the charging cart. A male connector (202) on the charging cart supplies power to the device via its charging port. Another male connector (204), a guide pin, on the charger mates with the guide pin hole on

the device. The presence of two male-to-female connections enables convenient alignment and blind mating of the device to the charging cart.

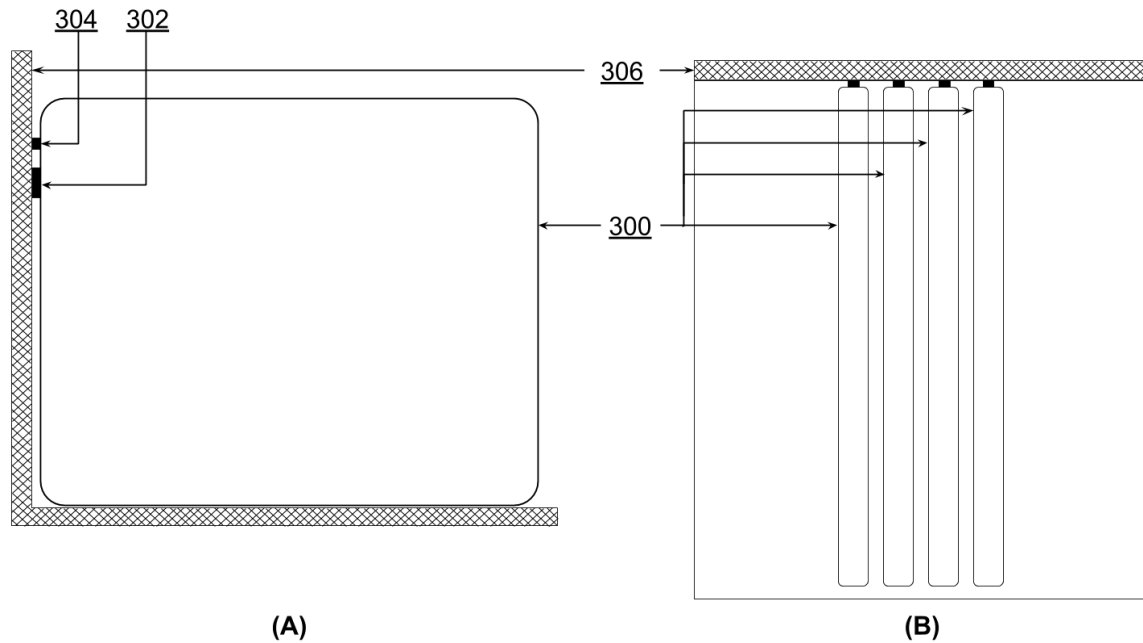

Fig. 3 (A) Side view of devices being charged on a charging cart (B) Top view of devices being charged on a charging cart

Fig. 3 illustrates side (Fig. 3A) and top (Fig. 3B) views of devices (300) being charged on a charging cart (306). A male connector (302) on the charging cart mates with the charging port on the device to provide power. Another male connector (304), a guide pin, on the charging cart mates with the guide pin hole on the device, and serves to make convenient the process of aligning and mating the device to the charger.

While Figs. 2 and 3 illustrate devices with a female connector, the device can alternatively have a male connector, e.g., a guide pin, and the charging cart can have a female guide pin hole. In some devices, the guide pin can be on an attachment that is near the charging port of the device.

The techniques of this disclosure thus enable compact, secure, and mobile charging of devices in a manner suitable for enterprise, education and other markets.

CONCLUSION

This disclosure describes techniques that place a guide pin hole next to the charging port of a device. The charger has a male element that fits into the guide pin hole. The guide pin hole makes it convenient to slide a device into a charger.