

# Voltage Stability Assessment Using Modal Analysis

Isaiah G. Adebayo<sup>1</sup>, David O. Aborisode<sup>2</sup>,

<sup>1,2</sup>Department of Electronic and Electrical Engineering, LAUTECH, P.M.B 4000, Ogbomoso, Oyo State, Nigeria

\* E-mail of the corresponding author: isaiahadebayo@yahoo.com

## Abstract

Voltage instability incidence has of recent been a major threat to the optimum operation of a modern power system due to continuous increase in load demand and insufficient reactive power to meet the demand. Thus, it becomes imperative to carry out voltage stability assessment in a power system to prevent the catastrophe of voltage collapse. This work present voltage stability assessment using a technique based on modal analysis of the reduced Jacobian. The modal analysis method makes use of the power system Jacobian matrix to find the eigenvalues essential for the evaluation of the voltage stability of a power system. The bus with the smallest value of eigenvalue is taken as the critical mode of the system. The participation factor (PF) of each load node is then determined to evaluate the bus which contributes most to the critical mode identified. The bus with the highest value of PF is taken as the critical bus of the system. The effectiveness of the methodology presented is tested on the IEEE 30 bus power system. Result obtained shows that voltage stability assessment using modal analysis method could be of a great importance to power system operators in the identification of critical nodes that are liable to voltage collapse in power system.

**Keywords:** Power flow, modal analysis, power system, voltage stability, participation factor

## 1. Introduction

The growing in number of power system blackouts in several countries in recent years has become a major cause of concern to power system utilities. The frequent occurrence of voltage instability, which may result from continues load growth or system contingencies, is essentially a local phenomenon. Considerable number of factors such as loss of a heavily loaded transmission line or insufficient reactive power supply, among others, could result in a voltage collapse or, in more serious cases, may lead to cascading outages and blackouts (Adebayo et al., 2018). Besides, sequences of events accompanying voltage instability may have catastrophic effects, including a resultant low-voltage profile in a substantial area of the power network, known as the voltage collapse phenomenon (Telang, & Khampariya 2015). Voltage collapse is characterized by a slow variation in the system operating point, as a result of increase in loads, in such a manner that voltage magnitudes slowly decrease until a sharp, accelerated change occurs (Adebayo et al., 2015, Adebayo et al., 2017). Recently, it has been observed that the voltage collapse issue is the root cause for numerous major network blackouts in various countries such as Belgium, France, Germany, Sweden, Iran, USA and Japan (FERC 2005, Moger & Dhadbanjan 2015). Substantial number of authors have addressed the study of voltage stability from different viewpoints. Most topics of interest related with voltage stability in the literatures has to do with: enhancement, assessment, bifurcation point, improvement, identification of weak bus among others (Cao et al., 2015, Lee 2016, . Kwatny et al., 1986). A significant voltage stability and voltage collapse prediction methods have been proposed in the literature (Ajjarapu & Lee. 1998). Techniques such as the use of PV and QV curves, continuation power flow, sensitivity analysis, optimization based, multiple load flow solutions, minimum singular value of power flow Jacobian, modal analysis to mention a few have been found very useful in the analysis of voltage stability in a power system. The modal analysis of the load flow Jacobian presented by Gao, Morisson and Kundur in 1992, is of great interest in this present work. This technique, in addition to providing an exact assessment of the system proximity to instability using the system eigenvalues, could also identify the elements of the power system contributing most towards incipient voltage instability (Telang, & Khampariya 2015). Thus, this present work is major on voltage stability assessment of the IEEE 30 bus power system using modal analysis method.

The remainder of this paper are organized as follows: Section 2 presents the mathematical formulation of modal analysis as presented by Gao et al., 1986. A brief description of the test case used is presented in section 3 while results and discussion are presented in section 4. Section 5 concludes the work.

## 2. Mathematical formulation of Modal Analysis of the reduced Jacobian matrix method

The modal analysis of the power flow of the Jacobian matrix as proposed by (Gao et al., 1992) is shown in the

form of linearized power flow of equation (1):

$$\begin{bmatrix} \Delta P \\ \Delta Q \end{bmatrix} = \begin{bmatrix} J_{P\theta} & J_{PV} \\ J_{Q\theta} & J_{QV} \end{bmatrix} \begin{bmatrix} \Delta\theta \\ \Delta V \end{bmatrix} \quad (1)$$

Since voltage stability analysis is depended on the reactive power of the system Q, thus, if the real power P is kept constant, then,

$$\begin{bmatrix} 0 \\ \Delta Q \end{bmatrix} = \begin{bmatrix} J_{P\theta} & J_{PV} \\ J_{Q\theta} & J_{QV} \end{bmatrix} \begin{bmatrix} \Delta\theta \\ \Delta V \end{bmatrix} \quad (2)$$

The incremental change in the reactive power of the load nodes can be expressed as:

$$\Delta Q = [J_{QV} - J_{Q\theta} J_{P\theta}^{-1} J_{PV}] \Delta V \quad (3)$$

$$J_R = [J_{QV} - J_{Q\theta} J_{P\theta}^{-1} J_{PV}] \quad (4)$$

$$\Delta Q = J_R \Delta V \quad (5)$$

The matrix  $J_R$  represents the reduced Jacobian matrix and it relates the bus voltage magnitude and bus reactive power injection directly. Therefore, from equation (5), the incremental change in voltage magnitude is given as:

$$\Delta V = J_R^{-1} \Delta Q \quad (6)$$

The modes of the power system network may be defined by the eigenvalues and the right and left eigenvectors of  $J_R$  (Sharma & Ganness 2007). Since  $J_R$  is a square matrix, application of eigenvalue decomposition technique on it will result in:

$$J_R = \zeta \lambda \tau, \quad (7)$$

where  $\zeta$  represents the left eigenvector of the reduced Jacobian matrix,  $\lambda$  depicts the diagonal eigenvalue matrix and  $\tau$  is the right eigenvector.

$$J_R^{-1} = \zeta \lambda^{-1} \tau \quad (8)$$

Substitution of equation (7) in equation (6) yields

$$\Delta V = \sum_i^n \frac{\zeta_i \tau_i}{\lambda_i} \Delta Q \quad (9)$$

Thus, the  $i^{th}$  modal voltage variation can be written as:

$$\Delta V_{mi} = \frac{1}{\lambda_i} \Delta Q_{mi} \quad (10)$$

We may infer from equation (10) that the voltage stability of a mode  $i$  with respect to changes in reactive power is defined by the modal eigenvalue. The right and left eigenvectors associated with the critical modes in the system can provide information concerning voltage instability, by identifying the element participating in these modes. The bus participation factor measuring the participation of the  $k_{th}$  bus to the  $i^{th}$  mode can be given as

$$P_{ki} = \Gamma_{ki} \Gamma_{ik} \quad (11)$$

Buses with large participation factors correspond to the most critical system buses.

### 3. Test Case Study of IEEE 30-bus power system

The effectiveness of the performance of the technique presented is tested on the IEEE 30-bus power system. This test system is made up of six generators, forty-one transmission lines with four (4) tap ratios and twenty four load nodes. The single line diagram of IEEE 30-bus power system is shown in Figure 1.

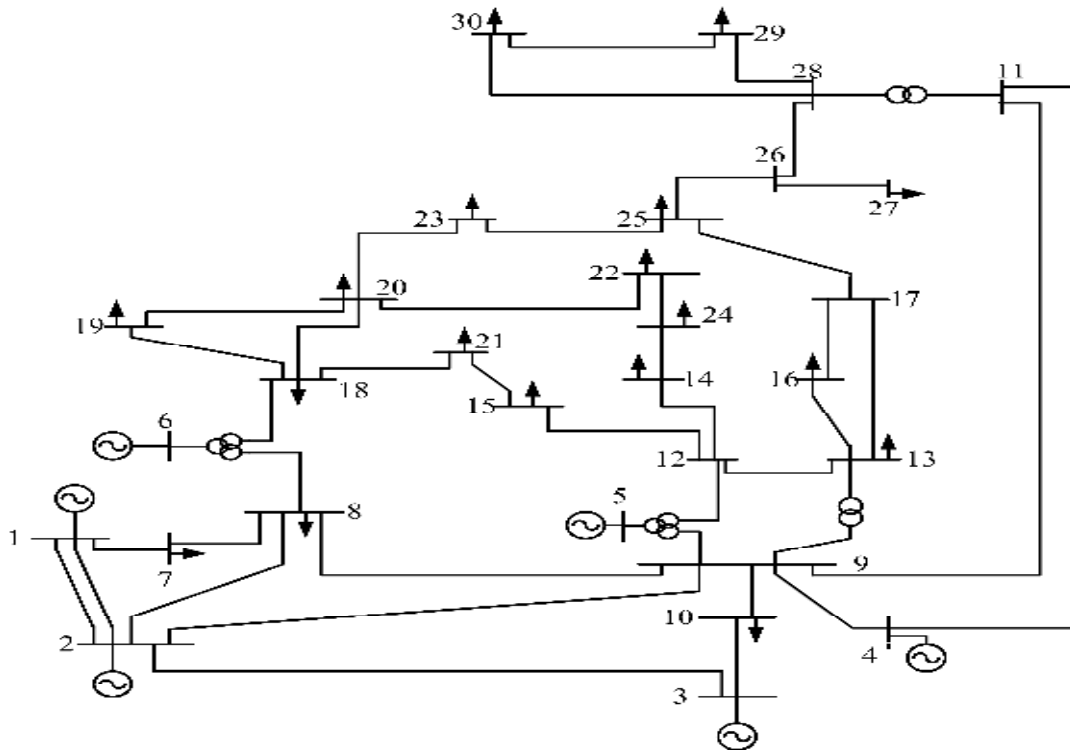

Figure 1: The IEEE 30 bus power system

#### 4. Simulation results and discussion

Power flow solution was first carried out to determine the voltage profile of each load bus of the IEEE 30 bus power system. MATLAB 2014a software is used for all the simulations performed. Result of the voltage profile obtained is shown in Figure 2. It could be seen that buses 27 and 30 have the least voltage magnitudes of 0.9605p.u and 0.9739p.u respectively. Next, for the modal analysis method, the eigenvalues of the IEEE 30 bus power system were first computed. Simulation results of the eigenvalues obtained show that the system is voltage stable as all the eigenvalues obtained are above zero and are positive. This is presented in Table 1. We then identified the smallest eigenvalues. The smallest eigenvalues was found to be 0.5021 and this correspond to mode 16. Mode 16 was then taken as the critical mode of the system. Bus participation factors to this critical mode are then generated to predict the critical buses in the IEEE 30 bus system. Based on the afore-established theory, the buses with highest participation factors were expected to be the most critical buses or buses closest to instability.

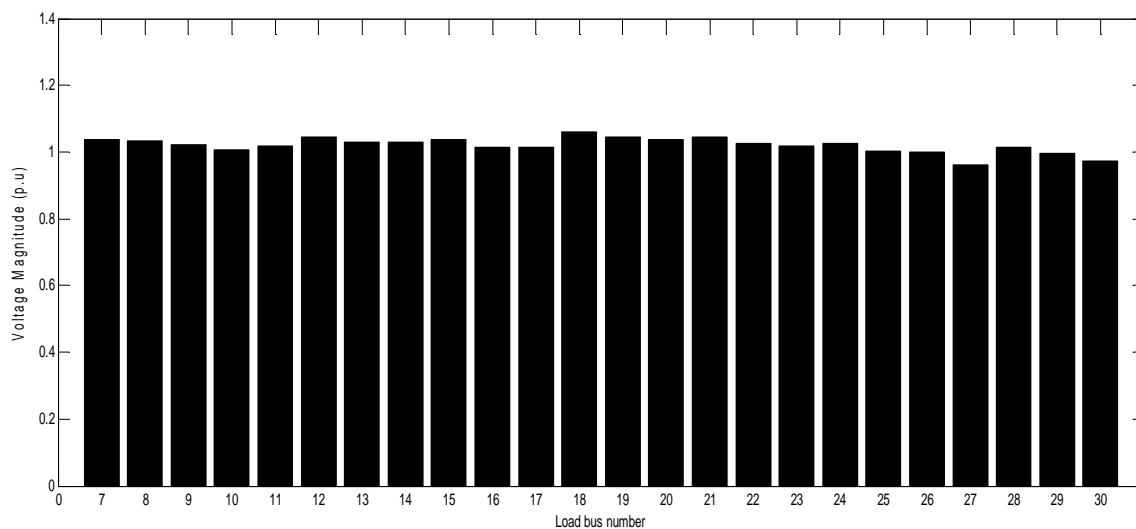

Figure 2: Voltage profile of the IEEE 30 bus power system

Table 1: Eigenvalues of the IEEE 30 bus power system

Mode	Eigenvalues
1	111.6068
2	99.5595
3	67.0189
4	49.4515
5	38.4084
6	35.5849
7	33.7787
8	23.3569
9	23.2873
10	19.0655
11	17.2975
12	15.7641
13	13.8283
14	12.9951
15	11.3505
<b>16</b>	<b>0.5021</b>
17	1.1617
18	1.6982
19	2.9108
20	4.0811
21	8.0464
22	7.1197
23	5.2353
24	6.1615

Table 2: Participation factor of the selected buses of the IEEE 30 bus power system

Ranking order	Load bus	Participation Factor	Total Computational Time (second)
7 <sup>th</sup>	23	0.0197	
8 <sup>th</sup>	24	0.0083	
6 <sup>th</sup>	25	0.0381	1.711932
4 <sup>th</sup>	26	0.1140	
2 <sup>nd</sup>	27	0.2033	
5 <sup>th</sup>	28	0.1097	
3 <sup>rd</sup>	29	0.1988	
1 <sup>st</sup>	30	0.2165	

The first eight weak buses of the IEEE 30 bus test system were considered. These buses are, 23, 24, 25, 26, 27, 28, 29 and 30. From these load buses, bus 30 has the highest value of participation factor (0.2165) as seen in Table 2. Thus, this bus is ranked as the most critical load bus of the IEEE 30 bus power system liable to voltage collapse. The order of ranking of the buses selected from the weakest bus are 30, 27, 29, 26, 28, 25, 23, and 24. It takes the total computational time of 1.711932 seconds to identify this voltage collapse bus using modal analysis technique.

## 5. Conclusion

The effectiveness of the power flow based modal analysis of the reduced Jacobian matrix for voltage stability assessment of a power system was demonstrated in this paper. MATLAB 2014a simulation tool box was used. The significance of the methodology presented in this work was tested on the IEEE 30 bus power system. Results obtained show that analysis of voltage stability in power system could be done using modal analysis method as it saves time and reduces computational burden. The method considered in this work may be utilized by power system operators and planners to analyze voltage stability at different operating conditions, as well as determine suitable remedial actions for voltage instability and voltage collapse.

## Reference

Adebayo, I. G., Jimoh A. A., Yusuff, A. A. & Sun, Y. (2018): Alternative method for the identification of critical nodes leading to voltage instability in a power system, African Journal of Science, Technology, Innovation and Development, DOI:10.1080/20421338.2018.1461967

Adebayo IG, Jimoh AA, Yusuff A (2017). Voltage stability assessment and identification of important nodes in power transmission network through network response structural characteristics. IET Gener Transm Distrib.;11(6):1398–408.

Adebayo, I. G., Jimoh A. A., Yusuff, A. A.(2015), "Detection of weak bus through Fast Voltage Stability index and inherent structural characteristics of power system," 2015 4th International Conference on Electric Power and Energy Conversion Systems (EPECS), Sharjah, 2015, pp. 1-5.

Cao, G. Y., L. N. Chen & K. Aihara (2015). Power System Voltage Stability Assessment Based on Branch Active Powers. In *IEEE Transactions on Power Systems*, 2015, 30(2): 989-996.

Lee, D. H. A., Voltage Stability Assessment Using Equivalent Nodal Analysis. In *IEEE Transactions on Power Systems*, 2016, 31(1): 454-463.

Jia, Z. & Jeyasurya, B., Contingency Ranking for On-Line voltage stability Assessment. In *IEEE Transactions on Power Systems*, 2000, 15(3):1093 – 1097.

Kwatny, H, Pasrija, A. & Bahar, L., Static bifurcations in electric power networks: Loss of steady-state stability and voltage collapse. In *IEEE Transactions on Circuits and Systems*, 1986, 33(10): 981-991.

Ajjarapu, V. & Lee, B.. Bibliograph on voltage stability. *IEEE Trans. On Power Systems*, 1998 13(1): 115-125.

FERC: 'Principles for efficient and reliable reactive power supply and consumption'. Docket No. AD05-1-000, FERC Staff Reports, USA, 2005

Gao, B., Kundur, P., Morisson, G.K, "Voltage Stability Evaluation Using Modal Analysis", *IEEE Transactions on Power Systems*, vol. 7, no. 4, pp.1423-1543, (November 1992). (15)

Moger, T and . Dhadbanjan , T. "A novel index for identification of weak nodes for reactive compensation to improve voltage stability," in *IET Generation, Transmission & Distribution*, vol. 9, no. 14, pp. 1826-1834, 11 5 2015.

Sharma, C. & Ganness, M. G., "Determination of the applicability of using modal analysis for the prediction of voltage stability," 2008 IEEE/PES Transmission and Distribution Conference and Exposition, Chicago, IL, 2008, pp. 1-7.

Telang, B, & Khampariya, P. "Voltage Stability Evaluation Using Modal Analysis", *International Journal of Scientific Research Engineering & Technology (IJSRET)*, ISSN 2278 – 0882, Volume 4, Issue 4, April 2015