

Analysis and Modelling of Single Slope Solar Still at Different Water Depth

Mohd Zaheen Khan, I. Nawaz

Department of Mechanical Engineering, Faculty of Engineering & Technology
Jamia Millia Islamia Jamia Nagar, New Delhi- 110025 India

Abstract

Although, more than two thirds of the earth is covered with water and remaining is land, all over the world, access to potable water by the people is narrowing and decreasing day by day. Most of the human diseases are due to polluted or non-purified water. Nowadays, each and every country is facing a problem of huge water scarcity because of pollution created by manmade activities. Adequate quality and reliability of drinking water supply is the fundamental need of all people on this earth. Fresh water, which was obtained from rivers, lakes and ponds, is becoming scarce because of industrialization and population explosion. Water purification using solar energy has become more popular because it is eco-friendly and cost effective. A solar still is commonly used device for water purification and it doesn't require any electricity for distillation of water. Solar distillation is a technology for producing potable water from brackish water or underground water of low quality at low cost. This method can reduce water scarcity problems in the world. In a solar still, water is evaporated using solar energy, which is a form of renewable energy and collected as distillate water after condensation of the vapour. This method can produce distilled water after removal of impurities. Since last three decades, more research work is going on to improve the system performance and efficiency of the solar still and provide a sustainable water purification. A variety of solar distillation devices have been developed with different materials and in different shapes in different locations to improve the efficiency of solar distillation. There is a strong need to improve the single slope solar still performance and increase the production of water distillation. The various factors affecting the productivity of solar still are: Climatic Parameters, Operational Parameters and Design Parameters. Among all these three parameters, main focus on the Operational Parameters; which are: Salinity, Mode of Operation, Amount of Dyes and Water Depth. From my literature survey, many researchers, engineers and scientists experimentally studied solar water distillation using Phase Change Materials. There is no more work. So, this present paper is focused on performance of solar water distillation using Phase Change Materials. In this study Magnesium Sulfate Heptahydrate ($MgSO_4 \cdot 7H_2O$), Sodium Sulphate ($Na_2S \cdot 7H_2O$) is used as phase change material and Titanium oxide is a Nano-material used for energy storage material. Among these energy storage materials Magnesium Sulfate Heptahydrate ($MgSO_4 \cdot 7H_2O$) improves the efficiency of solar water distillation.

Keywords: solar still, productivity, efficiency, phase change materials.

1. Introduction

Water is a basic necessity of man. Fresh water resources are considered to be rivers, lakes and underground water reservoirs. The use of water from rivers, lakes and underground is not always possible, especially because of the polluted environment. So search for other sources becomes a must. To overcome this problem, there are various methods to produce fresh water from seawater, saline water or brackish water. Desalination processes have received great attention as an alternative solution for fresh water production. Desalination is one of the methods, which is suitable for potable water. The demand for reliable and autonomously operating desalination systems is increasing continuously. These systems are meant for a basic need of drinking water and fresh water supply. Solar distillation seems to be a promising method and alternative way for supplying fresh water. Several solar still designs have been proposed and many of them have found significant applications throughout the world. Solar desalination systems have low operating and maintenance costs and require large installation areas and high initial investments. There are two different types of solar stills, those are; active solar still and passive solar still. Figure 1 indicates active type solar still; which contains the mechanical components like pump, valve etc. Figure 2 shows the passive type solar still which does not require mechanical components. Among active and passive solar stills, passive solar still gets more attractive compared to active solar still. Because, passive type solar still does not have moving elements, so no need of power consumption and no wear and tear problems. In this present work, focus is made on passive solar still.

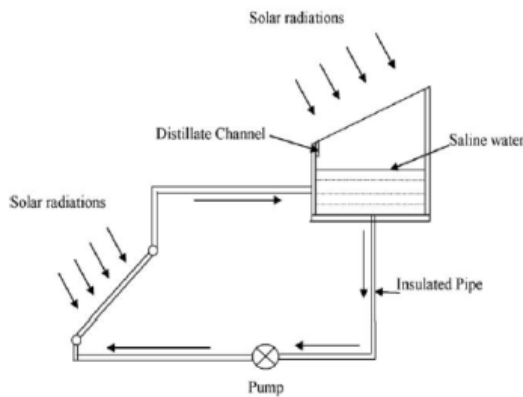

Figure 1: Active type solar still

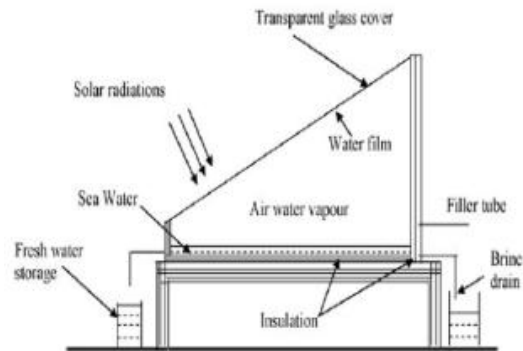

Figure 2: Passive type solar still

1.1 Experimental Procedure

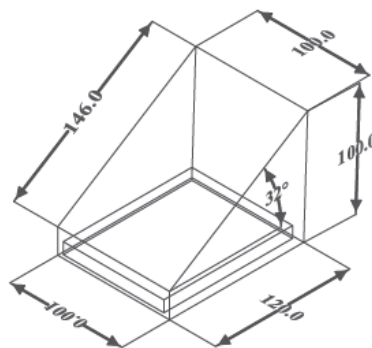

Figure 3: Single slope solar still

Above figure presents a schematic diagram of the solar still used in the present experimental study. It consists of a stainless steel basin, which has an effective area of 1m^2 . This solar still is made of Stainless steel with all dimensions in cm as shown in figure 3. The stainless steel sheet has a thickness of 0.8mm. It consists of a top cover of transparent glass with a tilt of 32° and is coated with black paint to absorb the maximum possible solar energy. This solar still faces south direction. The entire assembly is made air tight with the help of rubber gasket and clamps. Water enters in the basin through an inlet valve. To maintain constant water level of 8 cm, a floater is arranged inside the solar still. The distilled water is condensed on the inner surface of glass cover and runs along its lower edge. The distillate water was collected in a bottle and measured by a graduated cylinder. Thermocouples were located at different places of the solar still to measure temperatures such as outside glass cover, inside glass cover, basin water temperature, vapor temperature and ambient temperature. In this experiment Sodium Acetate is used as phase change material. All experiments were conducted in the month of August in Delhi, India.

1.2 Principle of Solar Desalination

A basin of solar still has a thin layer of water, a transparent glass cover that covers the basin and channel for collecting the distillate water from solar still. The glass transmits the sunrays through it and saline water in the basin or solar still is heated by solar radiation, which passes through the glass cover and absorbed by the bottom of the solar still. In a solar still, the temperature difference between the water and glass cover is the driving force of the pure water yield. It influences the rate of evaporation from the surface of the water within the basin flowing towards condensing cover. Vapour flows upwards from the hot water and condense. This condensate water is collected through a channel. Measuring Instruments are Pyranometer, Multimeter, Glass beaker, Pt-100 type thermocouples and infrared thermometer. Pyranometer is used to measure the direct solar radiation and diffused radiation. Glass beaker is used to measure the distillate water from the solar still. Pt-100 type thermocouples are used to measure the temperature of water, which is in the basin or solar still, inclined glass cover inside and outside temperatures. Infrared thermometer is used for measuring the atmospheric temperature.

2. Literature Review

Gnanadason et al (2011), has studied solar still using Nano fluids and they found that using Nano fluids in a solar still can increase the its productivity. The effect of adding carbon nanotubes to the water inside a single basin

solar still efficiency increases by 50%.

Celeta et al (2011) has studied the erosion and corrosion of metal surfaces using Nano fluid flow. They conducted their experiments for TiO₂, Al₂O₃, SiC, ZrO₂ nanoparticles with water as the base fluid where the Nano fluids flow in pipes made up of three different materials like aluminum, copper and stainless steel. They concluded that the Nano fluids have no effect on the erosion of the stainless steel pipe, while the aluminum pipe has highest erosion and they also found that ZrO₂, TiO₂ nanoparticles lead to highest erosion while SiC nanoparticles is lowest erosion.

3. Results And Discussion

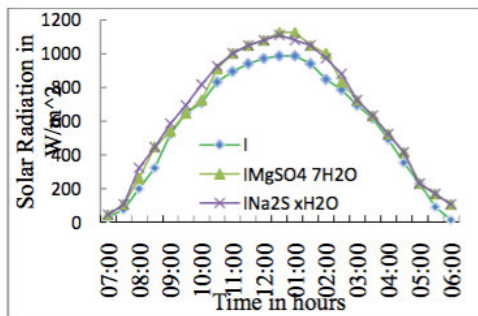

Figure 4: Variation of Solar Radiation with Time

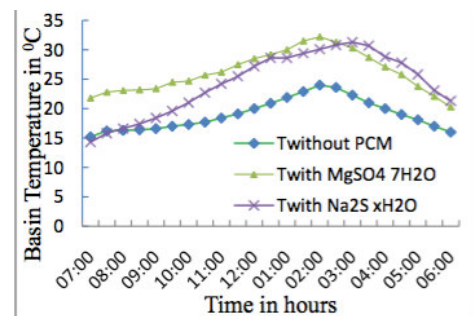

Figure 5: Variation of Basin Temperature with Time

Figure 4 shows the variation of solar radiation along with time during the daytime. Solar radiation increases up to 12 O' clock and decrease gradually. It follows the solar spectrum, i.e. solar constant is 1311 W/m².

Figure 5 shows the variation of basin temperature with time in a day. Increases basin temperature during early hours of the day and reaches the maximum basin temperature around mid noon and decreases as the sun sets.

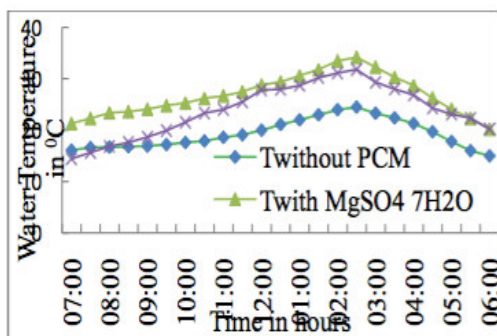

Figure 6: Variation of Water Temperature with Time

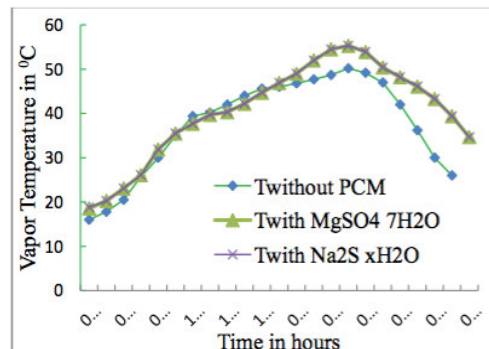

Figure 7: Variation of Vapor Temperature with Time

Figure 6 shows the variation of water temperature with time in a day. Increases water temperature during the day time and reaches the maximum water temperature around mid noon and decreases after words.

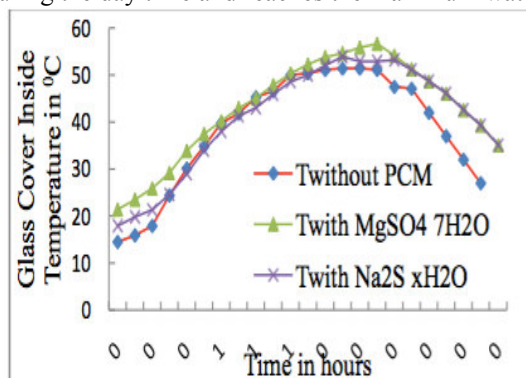

Figure 8

Variation of Glass Cover Inside Temperature with Time

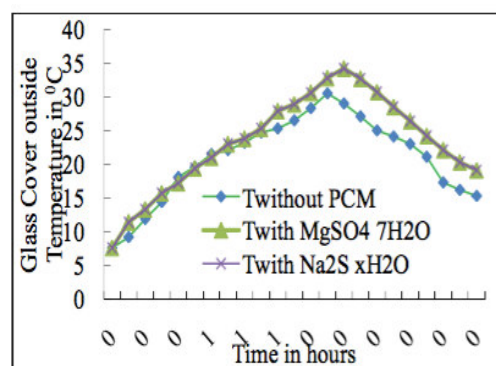

Figure 9

Variation of Glass Cover Outside Temperature with Time

Figure 7 to Figure 9 shows the variation of vapor temperature, glass cover inside temperature and glass cover outside temperatures respectively. In the above figures observed that maximum temperature reaches at mid daytime and in the presence of phase change material absorption of temperature is more.

4. Conclusion

It is known that, the solar distillation exhibits considerable economic advantages over the other water distillation processes. Because of less cost, free energy and reduces operating costs. Producing fresh water by a solar still with its simplicity would be one of the best methods to supply fresh water. In this experiment Magnesium Sulfate Heptahydrate ($MgSO_4 \cdot 7H_2O$), Sodium Sulphate ($Na_2S \cdot 7H_2O$) used as phase change material and Titanium oxide is a Nano material used for energy storage material. Among these energy storage materials Magnesium Sulfate Heptahydrate ($MgSO_4 \cdot 7H_2O$) improves the efficiency of solar water distillation.

Acknowledgement

I am thankful to Mechanical Engineering Department, Jamia Millia Islamia New Delhi for his encouragement. I am thankful to Prof G.N.Tiwari (Centre for Energy Studies), I.I.T Delhi for his kind help and suggestions during this work.

References

- [1] Al Hamadani, A. A. F., Shukla, S, K., 2011. Water Distillation Using Solar Energy System with Lauric Acid as Storage Medium. *International Journal of Energy Engineering* 1(1): 1-8.
- [2] Celata, G, P., Annibale, F, D., Mariani, A., 2011. Nanofluid Flow Effects on metal surfaces. *Energia Ambiente e Innovazione*, 4-5, 94-98.
- [3] El-Sebaili, A, A., Al-Ghamdi, A, A., Al-Hazmi, F, S., Adel, S, Faidah., 2009. Thermal performance of a single basin solar still with PCM as a storage medium. *Applied Energy*, 86, 1187-1195.
- [4] Gnanadason, M, K., Kumar, P, S., Rajakumar, S., Yousuf, M, H, S., 2011. Effect of nanofluids in a vacuum single basin solar still. *IJAERS*, 1, pp: 171-177.
- [5] Hima Bindu Banoth., Bhramara Panithapu., Ravi Gugulothu., Naga Sarada Somanchi., Devender, G., Devender, V., Banothu Kishan., 2014. A Review on Performance of Solar Still with Different Techniques. *Proceedings of International Conference on Renewable Energy and Sustainable Development (ICRESD 2014)*, pp: 393-398.
- [6] Mona, M, Naim., Mervat, A., Abd El Kawi., 2002. Non conventional solar stills part 2. Non conventional solar stills with energy storage element. *Desalination* 153, 71-80.
- [7] Muafag Suleiman K Tarawneh., 2007. Effect of water depth on the performance evaluation of solar still. *Jordan Journal of Mechanical and Industrial Engineering*, Volume 1, Number 1, September, pp: 23-29.
- [8] Nagas Srada Somanchi., Hima Bindu Banoth., Ravi Gugulothu., Mohan Bukya., 2014. A Review on Performance of Solar Still Coupled with Thermal Systems. *Proceedings of 2014 1st International Conference on Non Conventional Energy (ICONCE 2014)*, pp: 114-118.
- [9] Nijmeh, S., Odeh, S., Akash, B., 2005. Experimental and theoretical study of a single basin solar still in Jordan. *International Communications in Heat and Mass Transfer*, 32, 565-572.
- [10] Phadatare, M, K., Verma, S, K., 2007. Influence of water depth on internal heat and mass transfer in a plastic solar still. *Desalination*, 217, pp: 267-275.
- [11] Rahul, Dev., and Tiwari, G, N., 2009, Characteristic Equation of a passive solar still. *Desalination*, 245, pp: 246-265.
- [12] Rajesh Tripathi., Tiwari, G, N., 2005. Effect of water depth on internal heat and mass transfer for active solar distillation. *Desalination*, 173, pp: 187-200.
- [13] Rajesh Tripathi., Tiwari, G, N., 2006. Thermal modeling of passive and active solar stills for different depths of water by using the concept of solar fraction. *Solar Energy*, 80, pp: 956-967.
- [14] Rajendra Prasad, P., Padma Pujitha , B., Venkata Rajeev, G., Vikky, K., 2011. Energy efficient Solar Water Still. *International Journal of ChemTech Research (IJCRGG)*, Vol.3, No.4, pp:1781-1787.
- [15] Swetha, K., Venugopal., 2011. Experimental Investigation of a Single sloped still using PCM. *International Journal of Research in Environmental Science and Technology*, 1(4), 30-33.