

# Comparison Between Different Algorithms for Maximum PPT in Photovoltaic Systems and its Implementation on Microcontroller

Ahmed M. Fares<sup>1\*</sup> Belal A. Abo Zalam<sup>2</sup> Salwa G. El Nashar<sup>2</sup> Haitham Aka<sup>1</sup>

1. National Authority for Remote Sensing and Space Science NARSS, Cairo, Egypt.
2. Dept. of Industrial Electronics and Control Engineering, Faculty of Electronics Engineering, Menofia University, Menouf, Egypt.

\* Email: [eng\\_fares2007@yahoo.com](mailto:eng_fares2007@yahoo.com)

## Abstract

This paper presents the practical implementation of fuzzy logic control algorithm for maximum power point tracking (MPPT) in photovoltaic (PV) systems. A prototyping PV system is implemented with a boost DC-DC converter using Microchip<sup>®</sup> PIC18F452 microcontroller to execute the MPPT algorithms. The common algorithms like perturbation and observation (P&O) and incremental conductance (IncCon.) as well as the proposed fuzzy logic control algorithm are implemented and tested under different conditions, and the test results are analyzed and compared. The results show that the proposed fuzzy logic control algorithm can give better performance than perturbation and observation and incremental conductance algorithms.

**Keywords:** Photovoltaic, Maximum power point tracking, Fuzzy logic control, Microcontrollers.

## 1. Introduction

Photovoltaic (PV) based power systems are used today in many applications such as satellites, battery charging, home appliances and many more. So, the maximization of output power for photovoltaic systems (PV) has a great interest as the efficiency of the PV cells still not high enough.

The maximum power extracted from the PV generator depends strongly on three factors: irradiation, load impedance and cell temperature, assuming fixed cell efficiency [1]. The variation of the output I-V characteristic of a PV cell with temperature and irradiation variation is shown in Figs. 1 and 2 [2]. It can be observed that the temperature changes mainly affect on the PV output voltage, while the irradiation changes mainly affect on the PV output current.

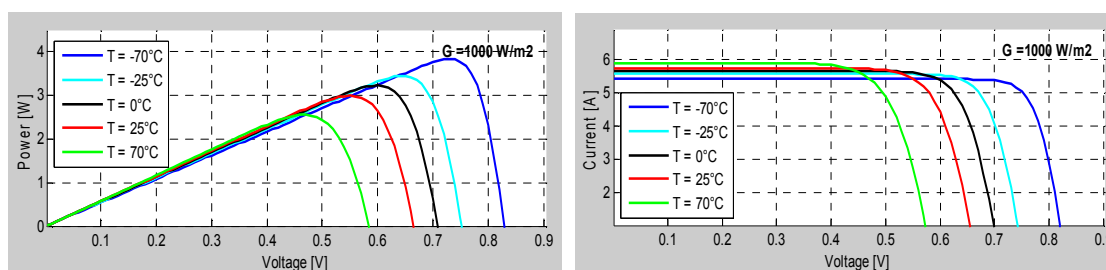

Fig.1. V-P, V-I Characteristics of a PV cell at constant irradiation level and various temperatures.

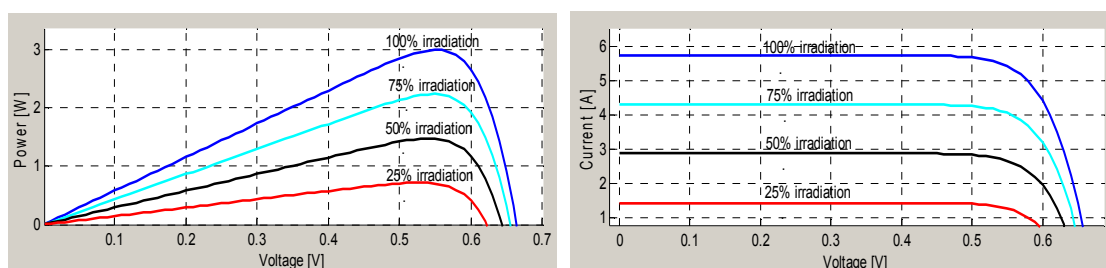

Fig.2. V-P, V-I Characteristics of a PV cell at constant temperature (25°C) and various irradiation levels.

The third factor, which affect on the PV output power, is the impedance of the load. In the present work, load consists of a DC loads with different impedances. When a PV generator is directly connected to the loads, the system will operate at the intersection of the I–V curve and load line, which can be far from the maximum power point (MPP) as shown in figure 3.

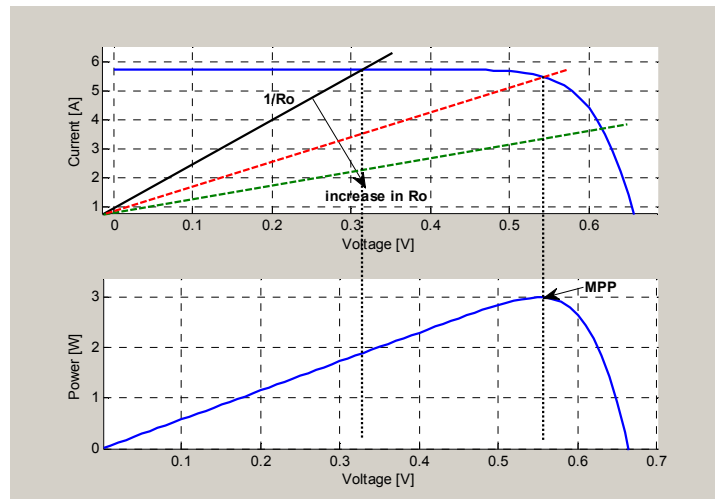

Fig.3. I-V curves of PV cell and various resistive loads

In order to overcome the above mentioned undesired effects on the PV output power, a maximum power point tracker (MPPT) is used for extracting the maximum available power from the solar PV panel and transferring it to the load. MPPT consists of a DC-DC converter and control circuit where there will be a MPP seeking algorithm.

Many tracking techniques and algorithms have been developed as the Fractional Open-Circuit Voltage method [3][6][7], the Fractional Short-Circuit Current method [3][4][5] as well as the Perturbation and Observation (P&O) method and the Incremental Conductance (IncCon.) method. The fractional open-circuit voltage assumed that voltage at MPP ( $V_{mpp}$ ) is proportional to PV open-circuit voltage ( $V_{oc}$ ). However, the estimated  $V_{mpp}$  is only an approximation of real  $V_{mpp}$  and the proportional constant will change with the PV panel aging, which means that the performance will degrade with time. Similarly for the fractional short-circuit current method. The Perturbation and Observation method has been widely used because of its simplicity and it is easy to implement, the idea of this algorithm is to periodically incrementing or decrementing the solar panel voltage then if a given perturbation leads to an increase (or decrease) in panel power, the subsequent perturbation is made in the same (or opposite) direction. In this manner, the peak power tracker, continuously seek the peak power conditions. However, this approach can be slow and thus can become 'confused' under rapidly changing atmospheric conditions.

The incremental conductance method compares the incremental conductance of the PV panel with its instantaneous conductance. The output voltage and current from the source are monitored upon which the MPPT controller relies to calculate the conductance and incremental conductance and to make its decision (to increase or decrease duty ratio output).

The present work describes the implementation of fuzzy logic control for maximum power point tracking (MPPT) for a PV system in comparison with the most commonly used algorithms (P&O and IncCon. algorithms). A microcontroller is used for control of the MPPT algorithm. The Proposed fuzzy logic algorithm, and the P&O as well as IncCon. algorithm are implemented and tested under different conditions and the results are analyzed and compared. The measured parameters such as panel voltage, current, power and temperature as well as the control parameters such as duty ratio are monitored and displayed on the PC.

## 2. MPPT Algorithms

The perturbation and observation (P&O) and the incremental conductance (IncCon.) algorithms as well as the proposed fuzzy logic control based algorithm, are described this section.

### 2.1 Perturbation and Observation

Perturbation and observation (P&O) algorithm is widely used in practice because of its simplicity and ease of implementation. In this algorithm a slight perturbation is introduced to the PV panel voltage, Due to this perturbation the power of the panel changes. If the power increases due to this perturbation then the perturbation is continued in that direction. After the peak power is reached the power at the next instant decreases and hence after that the perturbation reverses and when the steady state is reached the algorithm oscillates around the peak point. [8][9][10]. Figure 4 shows the flow chart of P&O method, where P and V represent PV panel power and PV panel voltage.

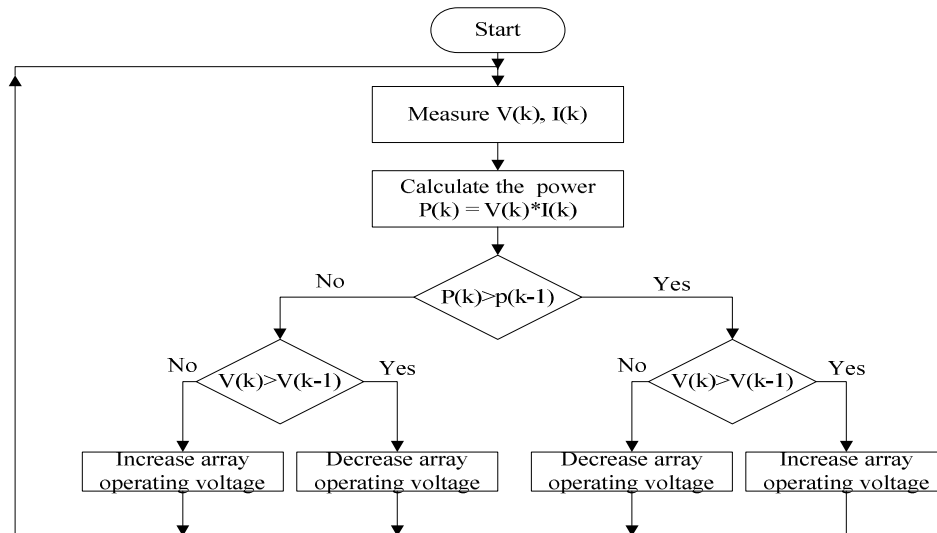

Fig.4. Flowchart of P&O algorithm.

The drawbacks of this method are that, at steady state, the operation point (OP) oscillates around MPP, the amplitude of this oscillation is proportional to the step size of perturbation. Also, it has been shown that P&O can exhibit erratic behaviour under rapidly changing atmospheric conditions [1][11].

### 2.2 Incremental conductance

The incremental conductance (IncCon.) algorithm is derived by differentiating the PV panel power equation with respect to voltage and setting the result equal to zero [10][11][12]. This is shown in Equations (1) to (5).

$$P = I * V \tag{1}$$

(Where P= PV panel power, V = PV panel voltage, I = PV panel current).

Differentiating eq. (1) with respect to dV:

$$\frac{dP}{dV} = I + V * \frac{dI}{dV} \tag{2}$$

From eq. (2), the basic equations of this method are as follows:

$$\frac{dI}{dV} = -\frac{I}{V} : \left( \frac{dP}{dV} = 0 \right) \text{ at MPP} \tag{3}$$

$$\frac{dI}{dV} > -I/V : \left(\frac{dP}{dV} > 0\right) \text{ left of MPP} \quad (4)$$

$$\frac{dI}{dV} < -I/V : \left(\frac{dP}{dV} < 0\right) \text{ right of MPP} \quad (5)$$

Figure 5 shows the flow chart of the IncCon. method, where P, V and I represent PV panel power, voltage and current respectively.

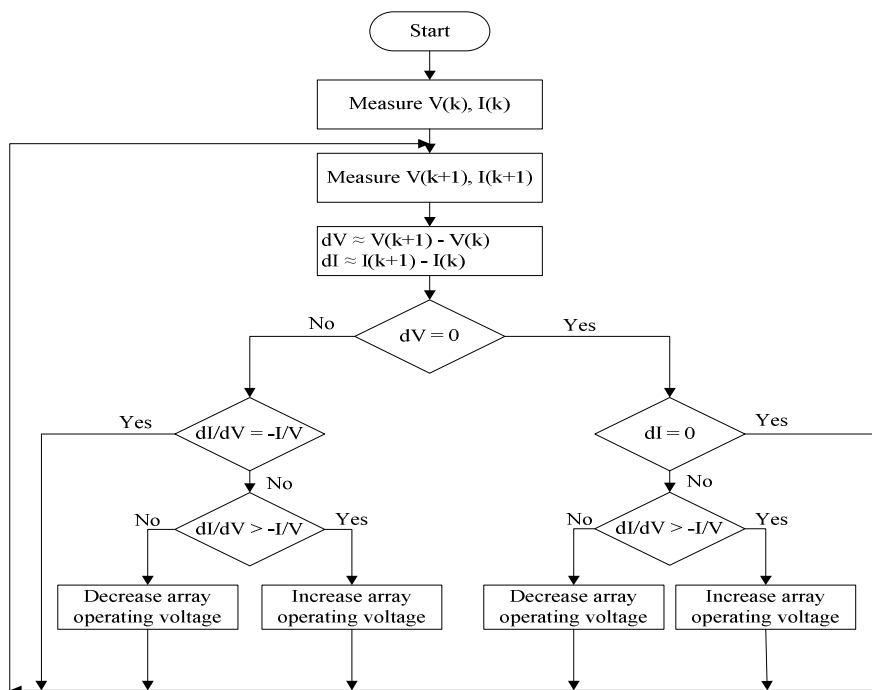

Fig.5. Flowchart of incremental conductance algorithm.

The main advantage of IncCon. algorithm is that it offers lower oscillation around the MPP than the P&O algorithm. Also, it offers a good performance under rapidly changing atmospheric conditions.

### 2.3 MPPT using Fuzzy Logic Control

Fuzzy logic controllers have been introduced recently in the tracking of the MPP in PV systems. They have the advantage to be robust and relatively simple to design as they do not require complete knowledge of the exact model and it can handle nonlinearity. The proposed fuzzy logic MPPT Controller, shown in Figure 6, has two inputs and one output. The two input variables are the error E and change of error CE at sampled times k defined by eq. 6 and 7, where P, V are the PV panel power and voltage respectively at instant k:

$$E(k) = \frac{P(k) - P(k-1)}{V(k) - V(k-1)} \quad (6)$$

$$CE(k) = E(k) - E(k-1) \quad (7)$$

The input  $E(k)$  shows if the operation point at the instant  $k$  is located on the right or on the left of the MPP on the PV characteristic curve as shown in figure 7, while the input  $CE(k)$  shows moving direction of this point. Where the control action  $D$  is duty cycle of PWM signal that control the boost converter.

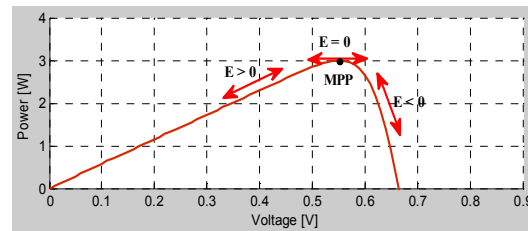
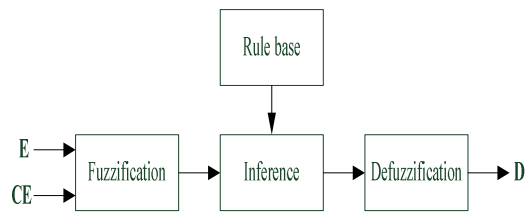

Fig.6. Block diagram of the fuzzy controller

Fig.7. PV cell power curve

The fuzzy controller includes three functional blocks, which are fuzzification, fuzzy rule algorithm, and defuzzification.

❖ *Fuzzification:*

The fuzzy logic controller requires that each control input variable to be expressed in fuzzy set notations using linguistic variables. These variables (characterized by membership functions) are used to decompose each system variable in the fuzzy regions. In this paper we use five linguistic variables for system inputs  $E$  and  $CE$  which are NB (negative big), NS (negative small), ZE (zero), PS (positive small) and PB (positive big), using basic fuzzy subsets as shown in Figure8.

❖ *The Fuzzy Rule Algorithm:*

The fuzzy rule algorithm includes 25 fuzzy control rules (listed in table1) that contain all the information for the controlled parameters. It is set according to experience and the operation of the system to be controlled. These rules are implemented by microcontroller and used for the control of boost converter (tracker) such that maximum power is achieved at the output of the solar panel at all different conditions. Fuzzy inference engine is an operating method that formulates a logical decision based on the fuzzy rule setting and transforms the fuzzy rule base into fuzzy linguistic output. In this paper using zero-order Sugeno fuzzy model [13] has been used.

❖ *Defuzzification*

The output of fuzzy controller is a fuzzy subset. As the actual system requires a non fuzzy value of control, defuzzification is required. In this paper the weighted average is used to compute the output of this FLC which is the duty cycle.

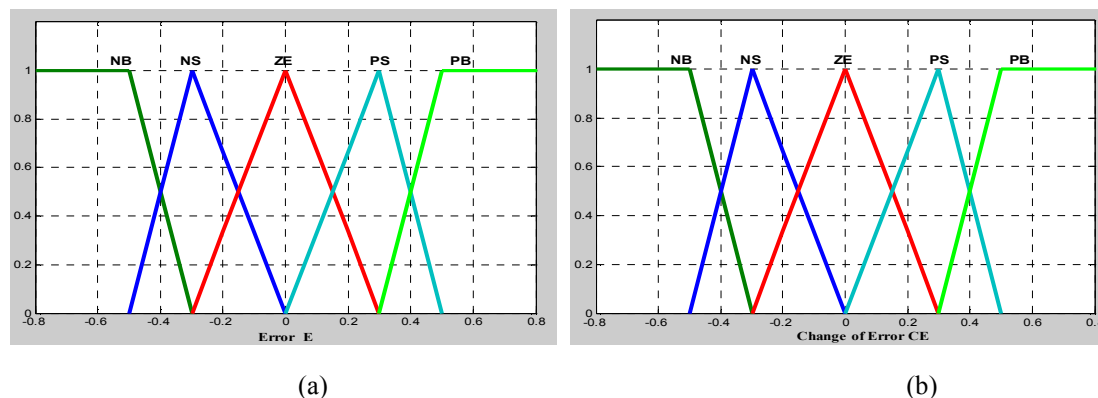

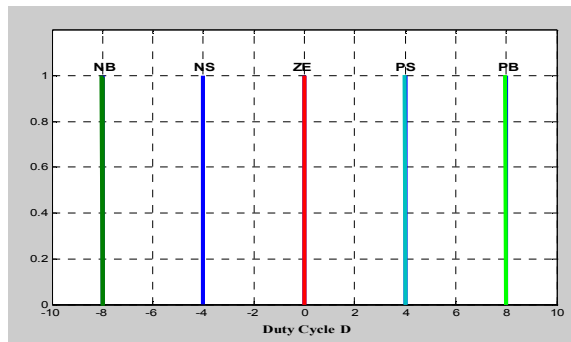

(c)

Fig.8. Membership function of E, CE and D

CE \ E	NB	NS	ZE	PS	PB
NB	ZE	ZE	PB	PB	PB
NS	ZE	ZE	PS	PS	PS
ZE	PS	ZE	ZE	ZE	NS
PS	NS	NS	NS	ZE	ZE
PB	NB	NB	NB	ZE	ZE

Table 1. Fuzzy rule table

### 3. Implementation

To test the performance of the proposed MPPT algorithm, the system shown in Figure 9 was implemented. The system consists of:

- 1) Solar panel.
- 2) DC/DC converter.
- 3) Microcontroller-based control board.
- 4) PC-based application software.

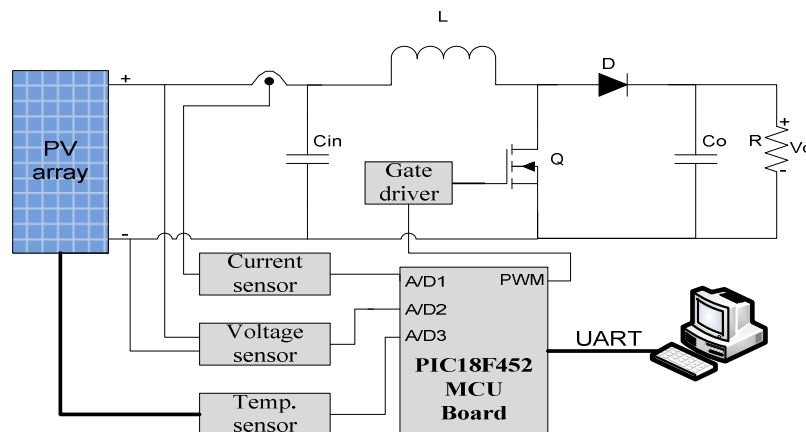

Fig.9. Block diagram of the proposed MPPT.

#### 3.1 Solar panel

The PV panel, which is to be used with this system, consists of 4 IXYS modules, model SLMD481H12, giving

around 4 W maximum power and around 15.2 V open-circuit voltage at an irradiation of 1000W/m<sup>2</sup> and temperature of 25° C. The PV module specifications are given by the manufacturer are shown in table 2. The sun light is simulated by a 750W halogen lamp as a light source for the PV panel. The panel equipped with LM35 temperature sensor to monitor its temperature during experiments.

### 3.2 DC/DC converter

The DC/DC converter here is a boost converter working at a switching frequency of 50 KHz, it is used to interface the PV panel output to the load and to track the maximum power point of the PV panel. The parameters of the converter are given in Table 3.

### 3.3 Microcontroller-based control board

The MPPT algorithms are implemented on a Microchip PIC18F452 MCU. This microcontroller features a 10-bit, eight channel A/D converter that used by the control program to measure the PV panel output current and voltage as well as panel temperature. Also, it features three PWM outputs with program controlled duty cycle that used to control the DC-DC converter to track the MPP. This family of microcontroller was chosen because it has the necessary features that required for the proposed system, such as big memory size, on-chip A/D converter, PWM outputs, low-power consumption and low cost.

### 3.4 PC-based application software.

Visual Basic software application was implemented to monitor the proposed system parameters online. It reads the measurements of the PV panel current, voltage, power and temperature as well as the controller output duty cycle from the MCU using UART port. The software has the ability to export these measurements to Excel for further off line analysis. Figure 10 shows the online monitoring of system parameters under the use of different algorithms as well as the case of MPPT-OFF using the PC-software.

Parameter	Value
open circuit voltage	7.56 V
short circuit current	200 mA
voltage at MPP	6.06 V
current at MPP	178 mA
maximum peak power	1081 mW
solar cell efficiency	22%

Table 2. Solar module specifications

Parameter	Value
Switching frequency	50 kHz
Inductance L	2.2 mH
Capacitor Co	100µF
MOSFET	110A 55V
Diode	20A 40V

Table 3. DC-DC converter parameters

## Experimental results

An extensive implementation and testing for the selected techniques has been done using the above-described system. Some selected results are presented with a comparison between P&O, IncCon and proposed fuzzy MPPT controllers. The following results were presented for different irradiation levels at fixed temperature as shown in Figure11, and at different temperature levels at fixed irradiation in Figure12, also at different loads at fixed temperature and irradiation level in figure13.

Fig.11 shows the experimental results of PV operating power for experiment time of 25 second the irradiation level has increased at time 10 second and decreased again at time 18.5 second at constant temperature of 30°C. The figure shows the result when using P&O, IncCon and fuzzy algorithms for MPPT.

Fig 12 shows the experimental results of PV operating power at varying temperature and constant irradiation. The figure shows the result when using P&O, IncCon and fuzzy algorithms for MPPT.

Fig.13 shows the output power of PV at fixed irradiation level and fixed temperature under load change for P&O, IncCon and fuzzy algorithms for MPPT as well as the case of MPPT-OFF. As shown the proposed fuzzy algorithm for MPP shows smother power signal line and better stable operating point than both P&O and IncCon algorithms.

Fig.14 shows the output power of PV at fixed irradiation level and temperature for P&O, IncCon and fuzzy

algorithms for MPPT. As shown IncCon algorithm shows less oscillating and better stable operating point than P&O., and the proposed fuzzy algorithm shows smother power signal line, less oscillating and better stable operating point than both P&O and IncCon algorithms.

From the experimental results, it can be deduced that the fuzzy logic based algorithm has better performance than both P&O and IncCon algorithms, and it has more accuracy for operating at MPP.

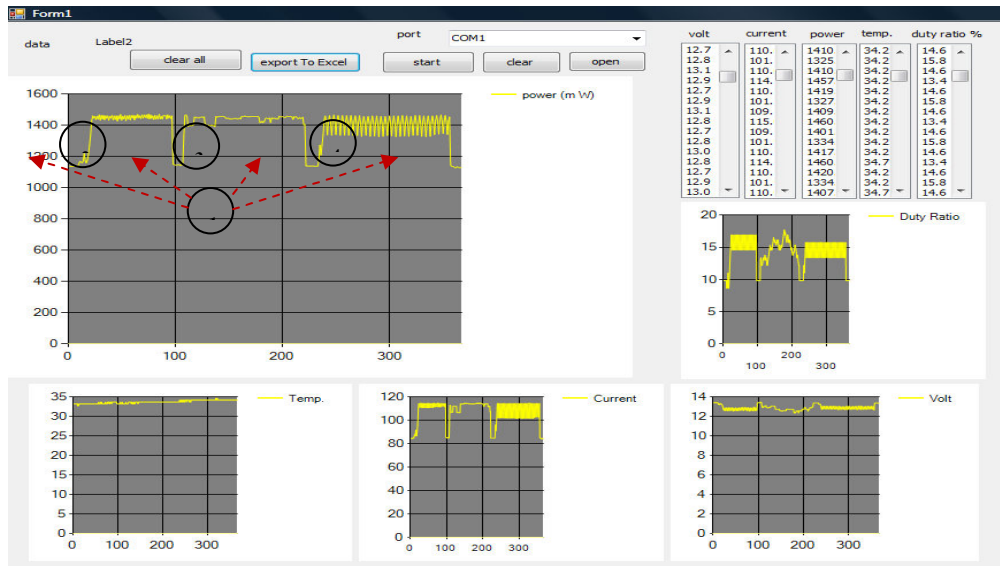

Fig.10. Online-monitoring of system parameters by the PC-based software.

- (1) PPT-OFF (2) PPT-ON with Inc. Con. Algorithm (3) PPT-ON with fuzzy control algorithm. (4)  
 PPT-ON with P&O Algorithm

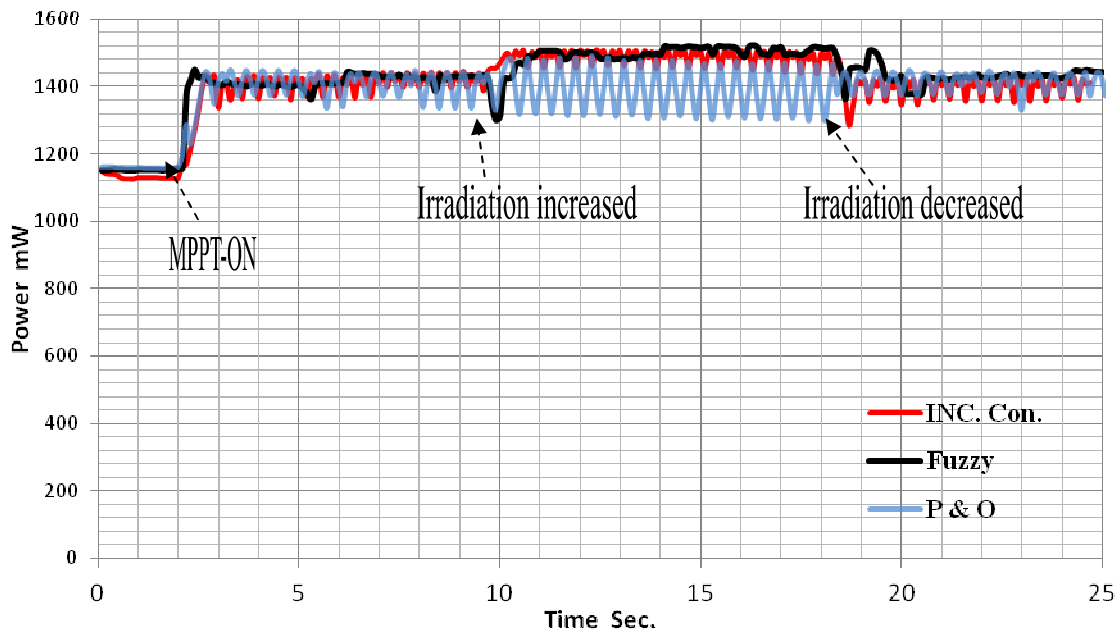

Fig. 11: Panel O/P power for different algorithms under change in irradiation and constant temperature.



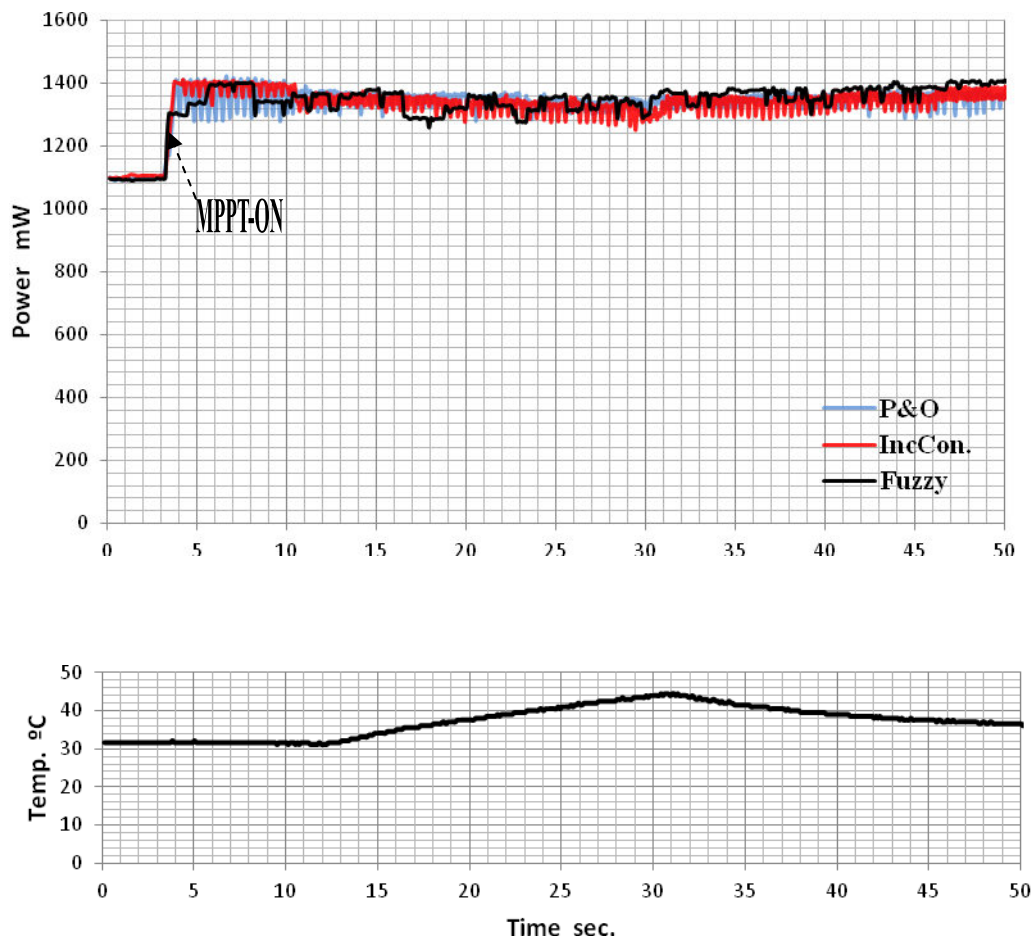

Fig. 12: Panel O/P power for different algorithms under change in temperature and constant irradianations.

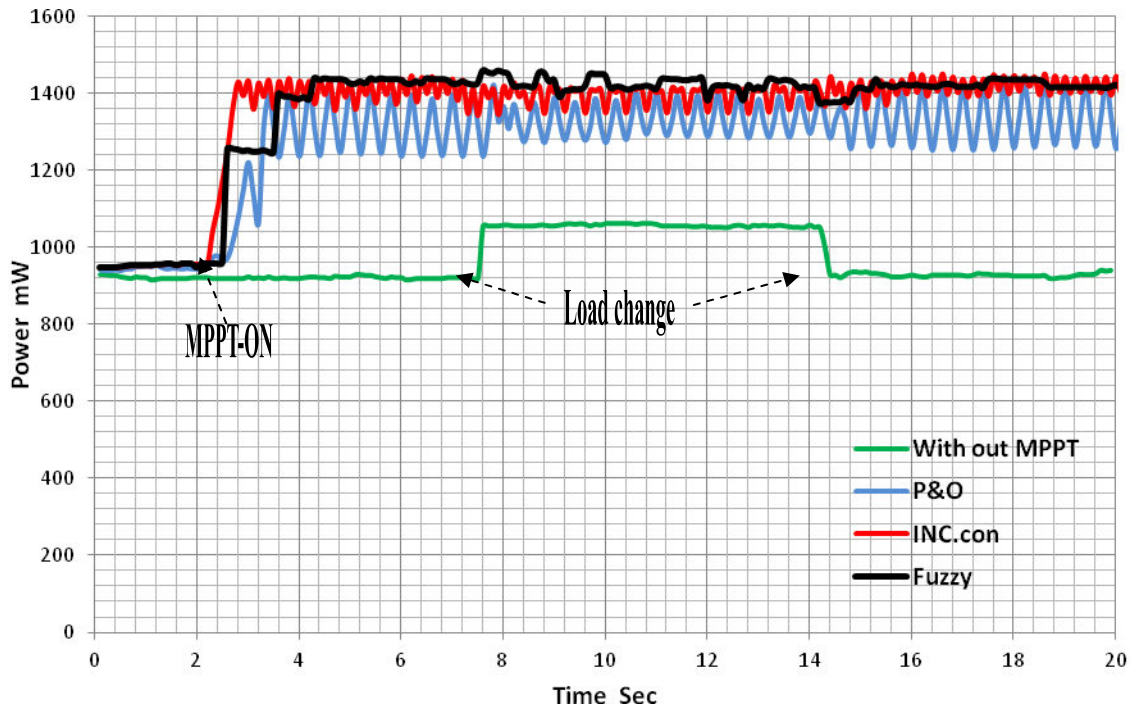

Fig. 13: Panel O/P power for different algorithms under change of the loads at constant temperature and irradiation

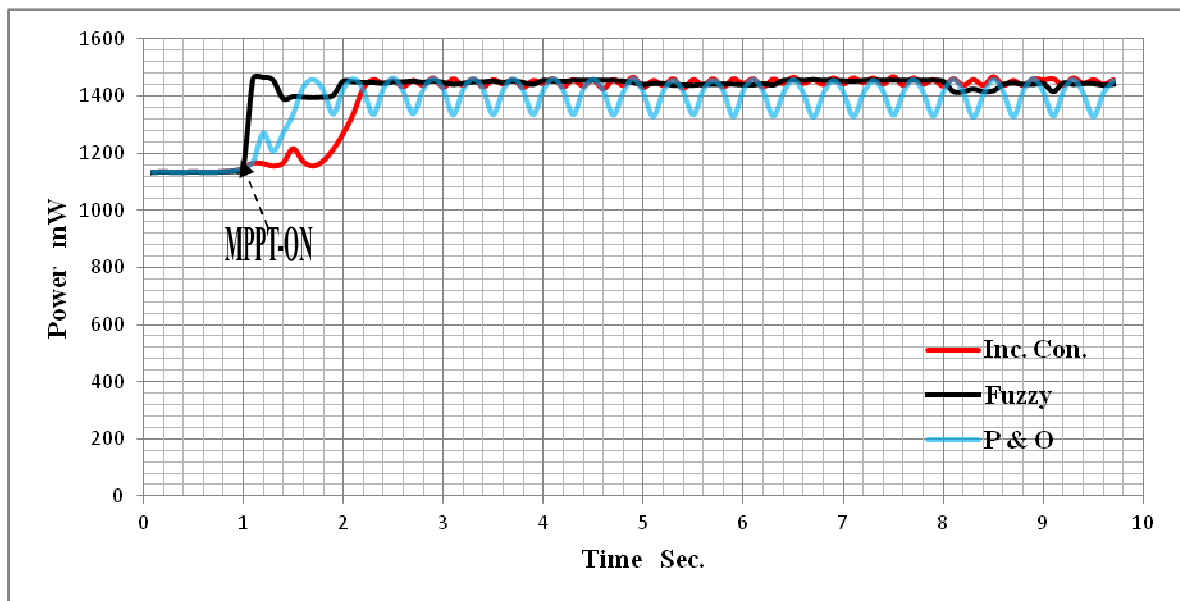

Fig.14: Panel O/P power with different algorithms at constant temperature and irradiation

### Conclusion

This paper discussed the implementation of different algorithms for MPPT on a microcontroller with photovoltaic system that is used to evaluate the performance of these algorithms. The fuzzy logic based algorithm is tested versus the most popular algorithms which are P&O and IncCon. algorithms. The algorithms were implemented and tested against change in irradiance, temperature and load. The proposed fuzzy algorithm

achieved better performance and efficiency comparable to the P&O and IncCon. algorithms.

## References

- [1] V. Salas, E. Ol'as, A. Barrado, A. La' zaro, "Review of the maximum power point tracking algorithms for stand-alone photovoltaic systems", *Solar Energy Materials & Solar Cells* 90, 2006, 1555-1578
- [2] Francisco M. González-Longatt, "Model of Photovoltaic Module in Matlab™" 2DO CONGRESO IBEROAMERICANO DE ESTUDIANTES DE INGENIERÍA ELÉCTRICA, ELECTRÓNICA Y COMPUTACIÓN (II CIBELEC 2005)
- [3] M. A. S. Masoum, H. Dehbonei, and E. F. Fuchs, "Theoretical and experimental analyses of photovoltaic systems with voltage and current-based maximum power-point tracking", *IEEE Trans. Energy Convers.*, 17(4), 2002, 514-522.
- [4] Chu, C.C., Chen, C.L., "A variable step maximum power point tracking for photovoltaic power system", *J. Chin. Soc. Mech. Eng.* 29 (3), 2008, 225-231.
- [5] Duru, H.T., "A maximum power tracking algorithm based on  $I_{mpp} = f(P_{max})$  function for matching passive and active loads to a photovoltaic generator", *Sol. Energy* 80, 2006, 812-822.
- [6] M. A. S. Masoum, H. Dehbonei, "Design, Construction and Testing of a Voltage-based Maximum Power Point Tracker (VMPPT) for Small Satellite Power Supply", 13th Annual AIAA/USU Conference on Small Satellites, August 1999.
- [7] Veerachary, M., Senjyu, T., and Uezato, K., "Voltage-based maximum power point tracking control of PV system", *IEEE Transactions on Aerospace and Electronics Systems* 38(1), 2002, 262-267.
- [8] Chihchiang Hua, Jongrong Lin, and Chihming Shen, "Implementation of a DSP Controlled Photovoltaic System with Peak Power Tracking", *IEEE Transactions on Industrial Electronics*, 45(1), 1998, 99-107.
- [9] Seok-II Go, Seon-Ju Ahn, Joon-Ho Choi, Won-Wook Jung, Sang-Yun Yun, Il-Keun Song, "Simulation and Analysis of Existing MPPT Control Methods in a PV Generation System", *Journal of International Council on Electrical Engineering*, 1(4), 2011, 446-451.  
Jung Y., So J., Yu G., and Choi J., "Improved perturbation and observation method (IP&O) of MPPT control for photovoltaic power systems", 31st IEEE Photovoltaic Specialists Conference, 2005, 1788-1791.
- [10] Hussein KH, Zhao G., "Maximum photovoltaic power tracking: an algorithm for rapidly changing atmospheric conditions", *IEE Proceedings of Generation, Transmission, Distribution*, 142(1), 1995, 59-64.
- [11] F. Liu, S. Duan, F. Liu, B. Liu, and Y. Kang, "A variable step size INC MPPT method for PV systems", *IEEE Trans. Ind. Electron.*, 55(7), 2008, 2622-2628.
- [12] B. Liu, S. Duan, F. Liu, and P. Xu, "Analysis and improvement of maximum power point tracking algorithm based on incremental conductance method for photovoltaic array", in *Proc. IEEE PEDS*, 2007, 637-641.  
Aurobinda Panda, M. K. Pathak, S. P. Srivastava, "Fuzzy Intelligent Controller for The Maximum Power Point Tracking of a Photovoltaic Module at Varying Atmospheric Conditions", *Journal of Energy Technologies and Policy*, 1(2), 2011, 18-27.
- [13] Sugeno, M., *Industrial applications of fuzzy control*, Elsevier Science Pub. Co., 1985.