

## ANALYSIS OF GRE PIPES WITH EPOXY RESIN COMPOSITE MATERIAL AND MATERIAL TEST SPECIFICATION

Thiyagarajan K<sup>1\*</sup>, Maria Antoine Pushparaj<sup>2</sup> & Shanmugam<sup>3</sup>

1. Department of Mechanical Engineering, Mailam Engineering College, Mailam, India.

2. School of Management, S.R.M. University, Kattangulathur, Chennai, India.

3. School of Mechanical Engineering, S.R.M. University, Kattangulathur, Chennai, India.

\*E-mail of the corresponding author : [kamarajvachu@gmail.com](mailto:kamarajvachu@gmail.com)

### Abstract

At present scenario composite materials has been extensively used in variety of fields right from households to aircrafts for its superior properties like lower specific weight, strength to weight ratio and modulus to weight ratio. In this project effort has been made to extend its application to pipes. Conventional pipes have its own disadvantages such as higher specific weight, low corrosion resistance and low strength which can be replaced by the composite pipes. Design of composite pipe has been done as conventional pipe for its inner diameter and its wall thickness. Structural analysis has been made with ANSYS 12 for its deformation and stress. Comparative study of ANSYS results for M.S.PIPES, and GRE pipes were done to justify the usage of GRE pipes. Filament winding process has been adopted to manufacture GRE pipes in a conventional lathe by implementing a winding setup. Hardness test and compressive test of GRE pipes to be done to assess its strength, leak and corrosion test for its ability to carry liquids.

**Key words:-**  $\{\sigma\}$  ij - Stress component,  $[C]$  ijkl - Stiffness matrix,  $\{\epsilon\}$  ij - Strain component,  $[S]$  ijkl - Compliance matrix, GRE - Glass reinforced epoxy, PAN - Poly acrylo nitrile.

### 1. Introduction To Composite Materials

#### 1.1 Polymer matrix composites

PMC are the one where matrix materials are made up of various polymers. Numerous amounts of polymer resin combinations are possible. Technically polymers are called as Resin. Typical classification of resins is thermoplastic resin and thermosetting resin. Various fibres such as carbon fibres, Kevlar fibres, SiC fibres and glass fibres can be used as reinforcement materials.

### 2. Polymer Matrix Composites.

#### 2.1 Thermo sets

Thermo set resins which readily Cross-link during curing. Curing involves application of temperature, pressure, and catalyst known as curing agent. Polyester, phenolics, polyimide and Epoxy are the typical thermosetting resin.

#### 2.2 Thermoplastics

Thermoplastics readily flow under stress at elevated temperatures, so allowing them to be fabricated into the required component, and become solid and retain their shape when cooled to room temperature. These resins can be recycled. Acrylics, Nylon, polystyrene, polyethylene, PEEK are the typical examples of thermo plastics resins.

#### 2.3 Rubber

Natural rubber is obtained from the LATEX from the Rubber tree whose content is 98% of polyisoprene. Nowadays various synthetic rubbers are available and these dominate the market, Synthetic rubbers are derived from the Butadiene. SBR and NBR are the typical synthetic rubber.

#### 2.4 Additives

Catalyst/Promoters – Thermosetting resins require both catalysts and promoters to cure. Again, a wide variety of options exist such as MEKP (methyl ethyl ketone peroxide), BPO (benzoyl peroxide), CHP (cumene hydrogen peroxide), DMA (dimethylaniline), CoNap (cobalt naphthenate) and others. Resin suppliers provide recommendations regarding correct levels of catalysts and promoters, and these should be strictly adhered to. The choice of which

catalyst/promoter system to use is usually a matter of fabricator preference, however, in some applications, superior performance can be achieved with one over the other (eg. BPO/DMA for Sodium Hypochlorite service).

### 3. Processing Of PMC:-

#### 3.1 Hand layup

In hand lay up the reinforcement is put down to line a mould previously treated with release agent to prevent sticking and perhaps a gel coat to give decorative and protective surface. Reinforcements can be many forms such as woven roving and chopped strand mat. Liquid resin is mixed with curing agent and applied to the surface of the reinforcements. This method is not suitable for the fabrication of pipes.

#### 3.2 Open mould

Open mould system includes matched die moulding uses sheet moulding compound and dough moulded compound as a raw material. Material to be shaped is pressed between heated matched die. Here only short fibres are used. This method is not suitable for manufacturing pipes.

#### 3.3 Filament winding process

This process is suitable for fabricating tubular structure. Fibres are wound in the mandrel with the required inner diameter. Fibres are guided by the squeeze rollers and impregnated with the resin. Required components are removed from the mandrel. This process is suitable for the fabrication of pipe.

### 4. Advantages Of PMC.

- Lower specific weight
- High modulus
- More toughness
- More economic
- Availability of raw materials

### 5. Law Of Mixture

Fabrication and properties are strongly influenced by proportion and properties of matrix and the reinforcements. Proportion can be expressed either via weight fraction which is relevant to fabrication, or via volume fraction which is used for property calculation.

$$\text{Volume fraction of fibre } v_f = V_f / V_c$$

$$\text{Volume fraction of matrix } v_m = V_m / V_c$$

$$\text{Weight fraction of fibre } w_f = W_f / W_c$$

$$\text{Weight fraction of matrix } w_m = W_m / W_c$$

$$v_f + v_m = 1 \quad \longrightarrow \quad 2.2.1$$

$$w_f + w_m = 1 \quad \longrightarrow \quad 2.2.2$$

Generalised form of any property can be written as

$$X_f v_f + X_m v_m = X_c \quad \longrightarrow \quad 2.2.3$$

#### 5.1 General anisotropic property

Composite materials are anisotropic in nature whose properties vary with the direction whereas conventional monolithic materials are isotropic in nature. Hooke's law can be adopted to the anisotropic materials as shown below.

#### 5.2 Generalized Hooke's law

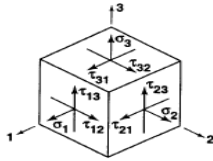

Figure no: 1 Generalized anisotropic characteristics

$$\{\sigma\}_{ij} = [C]_{ijkl} \{\varepsilon\}_{ij} \longrightarrow 2.2.4$$

$$\{\varepsilon\}_{ij} = [S]_{ijkl} \{\sigma\}_{ij}$$

Above equation indicates the generalized form of the hooks law for the anisotropic materials. It can be represented in three directional forms as given below.

$$\begin{bmatrix} \sigma_1 \\ \sigma_2 \\ \sigma_3 \\ \tau_{23} \\ \tau_{31} \\ \tau_{12} \end{bmatrix} = \begin{bmatrix} C_{11} & C_{12} & C_{13} & C_{14} & C_{15} & C_{16} \\ C_{12} & C_{22} & C_{23} & C_{24} & C_{25} & C_{26} \\ C_{13} & C_{23} & C_{33} & C_{34} & C_{35} & C_{36} \\ C_{14} & C_{24} & C_{34} & C_{44} & C_{45} & C_{46} \\ C_{15} & C_{25} & C_{35} & C_{45} & C_{55} & C_{56} \\ C_{16} & C_{26} & C_{36} & C_{46} & C_{56} & C_{66} \end{bmatrix} \begin{bmatrix} \varepsilon_1 \\ \varepsilon_2 \\ \varepsilon_3 \\ \gamma_{23} \\ \gamma_{31} \\ \gamma_{12} \end{bmatrix} \longrightarrow 2.2.5$$

### 5.3 Orthotropic materials

Orthotropic materials are the one whose properties are symmetry on the three mutually perpendicular axes. Generalized hooks law can be reduced to following equation

$$\begin{bmatrix} \sigma_1 \\ \sigma_2 \\ \sigma_3 \\ \tau_{23} \\ \tau_{31} \\ \tau_{12} \end{bmatrix} = \begin{bmatrix} C_{11} & C_{12} & C_{13} & 0 & 0 & 0 \\ C_{12} & C_{22} & C_{23} & 0 & 0 & 0 \\ C_{13} & C_{23} & C_{33} & 0 & 0 & 0 \\ 0 & 0 & 0 & C_{44} & 0 & 0 \\ 0 & 0 & 0 & 0 & C_{55} & 0 \\ 0 & 0 & 0 & 0 & 0 & C_{66} \end{bmatrix} \begin{bmatrix} \varepsilon_1 \\ \varepsilon_2 \\ \varepsilon_3 \\ \gamma_{23} \\ \gamma_{31} \\ \gamma_{12} \end{bmatrix} \longrightarrow 2.2.6$$

Orthotropic material can be characterized by the 9 independent elastic constants.

Important observations made are

- No couplings are made between normal stresses and shear strains.
- No couplings are made between stress and normal strain.

### 5.4 Transformation of stress and strain

If the fibre orientation is differ from the coordinates Then the transformation matrix is used to map the fiber coordinates to global coordinates following equation indicates the transformation matrix

$$\begin{bmatrix} \sigma_x \\ \sigma_y \\ \tau_{xy} \end{bmatrix} = \begin{bmatrix} \cos^2 \theta & \sin^2 \theta & -2 \sin \theta \cos \theta \\ \sin^2 \theta & \cos^2 \theta & 2 \sin \theta \cos \theta \\ \sin \theta \cos \theta & -\sin \theta \cos \theta & \cos^2 \theta - \sin^2 \theta \end{bmatrix} \begin{bmatrix} \sigma_1 \\ \sigma_2 \\ \tau_{12} \end{bmatrix} \longrightarrow 2.2.7$$

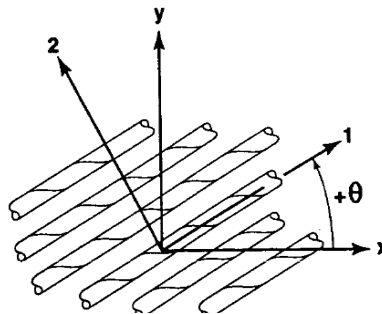

Figure no: 2 Transformation of co-ordinates

## 6. Strength Of Composite Materials

It has been seen that in a simple aligned fibre composite, loaded parallel to the fibres that both the matrix and the fibre experience the same strain (amount of stretch). It would be logical therefore to expect the composite to break at the lower of the matrix fracture strain or the fibre fracture strain. There are two cases to consider, firstly, where the matrix fails first and secondly, where the fibre fails first. The former situation is common in polymer matrix composites with low strength brittle matrices such as polyesters, epoxies or bismelamides, the latter case is observed in metal matrix composites or thermoplastic polymer composites where, because of plastic deformation in the matrix, the failure strain of the fibre is the smaller value.

### 6.1 Matrix failure

At low volume fractions of fibers, the matrix constitutes the major load bearing section and the addition of fibers gradually increases the strength as the applied load is partitioned between the fibers and the matrix. However, when the strain in the composite reaches the fracture strain of the matrix, the matrix will fail. All of the load will then transfer instantly to the fibers, which occupying such a small fraction of the sample area will see a large jump in stress and they too will fail. When the composite is deformed the elastic modulus is linear. At the strain at which the matrix is about to fracture,  $\epsilon_m$ , the stress in the composite can be determined using Hookes' Law since both the fibre and the matrix are still behaving elastically, i.e.

$$\begin{aligned} \sigma &= E \epsilon_m \\ &= f E_f \epsilon_m + (1 - f) \sigma_m \end{aligned} \quad \longrightarrow \quad 2.3.1$$

The stress in the matrix,  $\sigma_m$ , is now equal to the matrix fracture stress, but the stress in the fibre is still much less than the fibre fracture stress - we know this because the stress in the fibre is simply calculated using Hooks' Law. What happens next, as the matrix breaks, depends on the mode of loading, either constant deflection (deflection rate) i.e. the end points of the composite are fixed or constant load (loading rate) where there is a dead weight hanging off the end of the composite. Ultimately, the distinction is irrelevant to the overall strength of the composite but affects the shape of the stress-strain curve. We will just consider the case of dead weight loading. Before the matrix breaks, the load on the composite is

$$\begin{aligned} F &= \sigma A = (f E_f \epsilon_m + (1 - f) \sigma_m) A \\ \sigma &= \frac{F}{f A} = \frac{f E_f \epsilon_m + (1 - f) \sigma_m}{f} \end{aligned} \quad \longrightarrow \quad 2.2.9$$

### 6.2 Fiber failures

After the matrix breaks only the fibres remain to carry the load and the stress in the fibre jumps by  $\left(\frac{1}{f} - 1\right)\sigma_m$ . If this increase takes the stress in the fibre above its fracture strength then the fibres too will snap. This is most likely to happen when  $f$ , the volume fraction of fibres is small and when the strength of the matrix is large. This is called matrix controlled fracture. However, if the jump in stress is not sufficient to break the fibres then the load can be increased until the fibres break i.e.

$$\sigma = fE_f \epsilon_f(\sigma) = f\sigma_f \longrightarrow 2.3.1$$

## 7. Conventional Pipe Materials

Conventional material that are used as pipe are as follows

- M.S.pipe
- GI pipes
- SS pipes
- PVC pipes

## 8. Selection Of Composite Materials

### 8.1 Thermoplastic resins

Thermoplastic resin generally has linear molecular structure so it is having low stiffness and lower temperature characteristics. This led to change in focus on thermo setting plastics. Following comparison helps to make a decision.

Table no 4.1 Comparison of thermo and thermo plastics

Properties	Thermoset plastics	Thermo plastics
Young's modulus ( Gpa)	1.3-6	1-4
Tensile strength (Mpa)	20-180	40-160
Fracture toughness (Mpa <sup>1/2</sup> )	0.5-1	1.5-6
Maximum service temperature (°c)	50-450	25-200

### 8.2 Thermosetting resin

Thermo setting resin has its advantages of higher stiffness, moderate strength, higher temperature characteristics and higher chemical resistance which is suitable for the manufacturing of the pipes. From the following thermo set resin any one can be selected for pipe fabrication.

Table no 4.2 comparison of properties of resin

Resin	Stiffness Gpa	Cost	Tensile strength Mpa	Specific gravity
Polyester	1.3-4.5	less	45-85	1.1-1.5
Phenolics	4.4	less	50-60	1.3
Polyimide	3-3.1	More expensive	80-190	1.2-1.9
Epoxy	2.1- 6	expensive	35-90	1.1-1.4

## 9. Resins

### 9.1 Polyesters

A common resin that dominates the market. Linear polyesters can be dissolved in styrene. Cross link polyesters are inexpensive resin and have low viscosity however shrinkage on curing is high. Since it is having relatively low strength and stiffness it was not the choice for pipe fabrication.

### 9.2 Phenolics

Phenolics are the oldest thermo plastics. Because of their low cost and good balance of properties they find many applications. They are good fire resistant. Undesirable factor of Phenolics are they produce volatile by products and often need high pressure and temperature. It has relatively low strength and stiffness it was not the choice for fabrication of pipes.

### 9.3 Polyimide

Polyamides are more expensive and less widely used than polyesters or epoxies but can with stand relatively high temperature s. Owing to presence of ring structure it is having high strength. Because of its high cost it was not been a choice.

### 9.4 Epoxy

Epoxies are relatively expensive than poly ester and phenolics but following superior properties made them a choice for the fabrication of pipes. It is more Viscous than any other thermo set plastic which has been an ideal choice for a filament winding process where impregnation of fibre can be done easily. Curing can be done easily up to 180 c with two stages. It has typically low shrinkage on curing .It often provides better interactions with glass fibres. It is having relatively high stiffness and strength making them to make a choice for fabricating pipes.

## 10. Selection Of Reinforcement Materials

### Properties of fibres

Reinforcements phase of a composites maybe in the form of continuous or short fibres, particles of various shapes and whiskers. It contributes to determine the composite stiffness and strength. Desirable characteristics of fibre are high strength and stiffness and relatively low density.

Table no 1. properties of fibres

Fibre	Young's modulus Gpa	Tensile strength Mpa	Density Mg/m <sup>3</sup>
Aramid	130	2900	1.44
Alumina	380	1400	3.9
Carbon	380	2700	1.86
Boron	420	3500	2.65
Glass	70	2200	2.54

### 10.1 Carbon fibres

Carbon fibres are mostly used in advanced composites for its range of stiffness and strength. Carbon fibres are usually manufactured from the organic precursors such as PAN and Rayon .Carbon fibres are commercially available in the form of HS, IM and HM. Even though carbon fibres is having variety of stiffness and strength ranges .It costs more this could lead to high cost of the pipe. This could not be the right choice of fibre.

### 10.2 Aramid

Aramid fibres are manufactured by dissolving polymer in the sulphuric acid and extruded through the small hole in a rotating device. Nevertheless Aramid fibres are having high strength and modulus compared with the other fibres it has low compressive strength and absorbs high moistures this would lead to erosion of pipes. So this fibre also is not

the right choice.

### 10.3 Alumina

Ceramic fibres such as alumina are having stiffness and withstand higher temperature. It costs more and having relatively low strength. So this is also not been the right choice.

### 10.4 Glass

Glass fibres are the most commonly used in low and medium performance composite because of their high tensile strength usually a coupling agent is applied on the surface to protect the surface and ensure bonding with the resin. This has been a good choice for the moderate performance at relatively low cost.

## 11. Design Of Composite Pipes

### 11.1 Design considerations

It was intended to carry a fluid for a distance of 1 kilometre. Following parameters have been considered for consuming low power to transport the fluid.

### 11.2 Specification of GRE pipes

Material = Glass reinforced Epoxy

Inner diameter = 50mm.

Wall thickness = 3mm.

$$P = 136.7\text{N/mm}^2$$

### 11.4 Pressure rating of steel pipes

$$\text{Hoop stress } f_1 = Pd / 2t$$

$$\text{Pressure developed inside the pipe } P = (6 \times 351) / 50 = 42.12\text{N/mm}^2$$

### 11.5 Types of fluids

Newtonian fluid of 0.9 specific gravity with the viscosity of 0.1 stokes with the pressure rating 2.736 N/mm<sup>2</sup> and discharge of 4lit/sec.

## 12. Composite Modeling With Ansys

Modeling composites within any FEA software has three important stages different than modeling any isotropic material: choosing proper element type, defining the layers of the element and defining the failure criteria for the material .ANSYS has more than 40 different material models, such as linear elastic models, nonlinear elastic models, nonlinear inelastic models, foam models, pressure dependent plasticity models or equation of state models, etc. Within these models, composite materials can be modeled using layered elements with orthotropic or anisotropic material properties. In order to model layered composite materials; ANSYS serves a number of layered element types [36]:

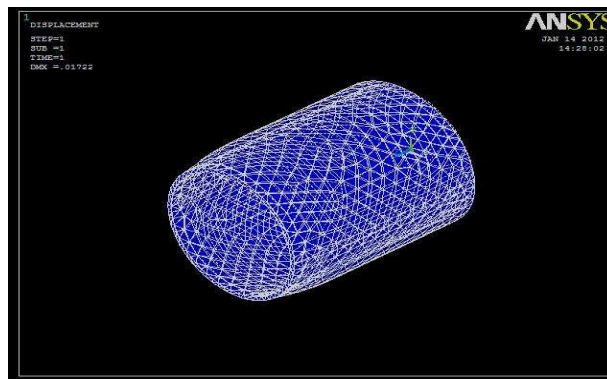

Figure No: 3 Deformation Plot of Steel

SHELL 99- Linear Layered Structural Shell Element,

SHELL 91 - Nonlinear Layered Structural Shell Element,

SHELL 181 - Finite Strain Shell,

SOLID 46- 3-D Layered Structural Solid Element,

SOLID 191- Layered Structural Solid Element,

In addition, SOLID 95, SHELL 63 and SOLID 65 elements can also be used for composite modeling with some key options; basically for single layers or for approximate calculations. The type of element to be used in the model depends on the specific application, and the results that are needed at the end of the analysis. As a rule in finite element analysis technique: if one dimension of the model is 10 or more time greater than the other two, shell elements should be preferred instead of solid38 elements. If two dimension of the model is 10 or more times greater than the other one, beam elements should be preferred [36].Shell elements can be imagined as collapsed solid elements, which have negligible through thickness stress values. Since some edges are absent in shell elements, generally more degrees of freedom (rotational degrees of freedom) are defined for nodes of a shell element.

For our specific application, solid elements should not be used due to geometrical considerations. SHELL 91 is not preferred either, since it is used with nonlinear applications such as large strain, sandwich construction or plasticity. SHELL 181 is not preferred since highly nonlinear behavior exists. Layered configuration can be modeled by specifying the layer properties; such as material properties, orientation angle, layer thickness and number of integration points per layer. For SOLID 46 and SHELL 99 element types of ANSYS, constitutive matrices can be defined with an ‘infinite number of layers’ opportunity.

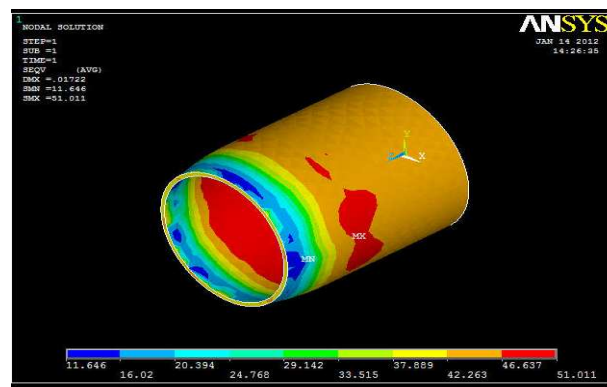

Fig no:- 4 VONMISES STRESS:- Stress analysis of a steel pipe

Within Layered configuration, SHELL 63, SHELL 91, SHELL 181 and SHELL 63 elements of ANSYS permit sandwich construction using one layer and real constants. It is possible to model ply drop-off, by using SHELL 181, SHELL 91 and SHELL 99 elements, by the method of node offsetting. ANSYS permits to use three different failure criteria for composites: Maximum Strain Failure Criterion, Maximum Stress Failure Criterion and Tsai-Wu Failure Criterion. Within these models, failure strains, failure stresses and coupling.

Coefficients in all directions of orthotropic or anisotropy can be modeled as temperature dependent parameter. ANSYS Parametric Design Language can be used in analyzing a composite structure. See ‘Section 2.3’ for details on APDL. For an application, it should be decided whether which element type or material model to use. Then the layered configuration should be defined. Layer orientation and orthotropic properties should be checked. Before running the analysis, failure criteria should be chosen.

### 12.1 Shell 99 Elements

Shell 99 is an eight node Linear Layered Structural Shell Element, which can be used to model composite structures up to 250 layers. Beyond this value, using a user-input constitutive matrix, more than 250 layers can be modeled. It does not support some nonlinear properties that SHELL 91 supports, but it has smaller computational time. Shell 99 has eight nodes: four corner nodes and four midside nodes. Each node has six degrees of freedom: translations in three directions and rotation about three axes. An average or each corner thickness can be defined explicitly, which gives a bilinear varying thickness over the area of the layer, with the thickness input at the corner node locations.



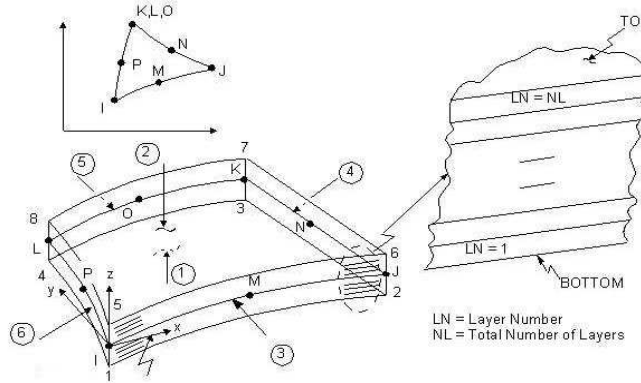

Figure no 5:-shell 99 element

### 13. Analysis Of Gre Pipes

#### 13.1 Pre Processor

Pre-processor includes selection of elements, defining material properties, modeling and meshing.

#### 13.2 Element Selection

Selection of element for the composite material is a typical one. Shell element is suitable for analysing composite materials. Since this pipe configuration involves in winding process layered concept was introduced. Shell 99 element with layered configuration has been chosen. Following figure indicates the layered configuration.

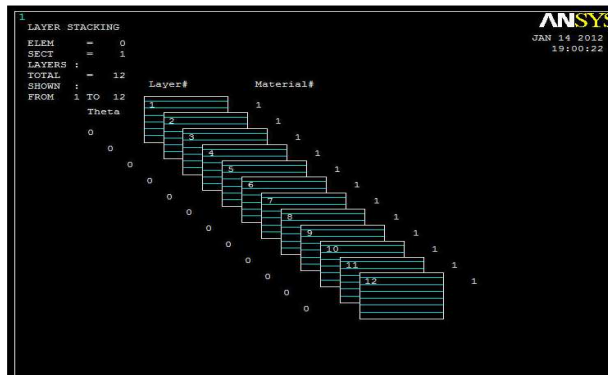
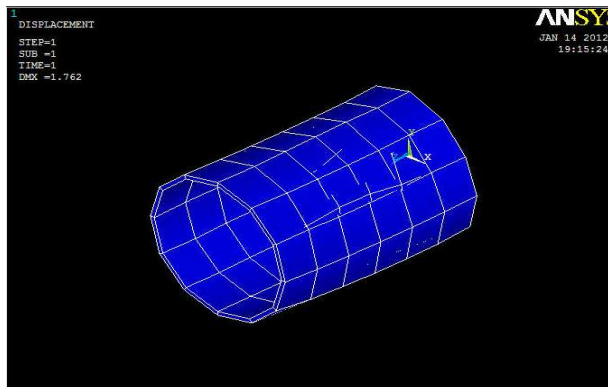

Figure no 6: Layer configurations



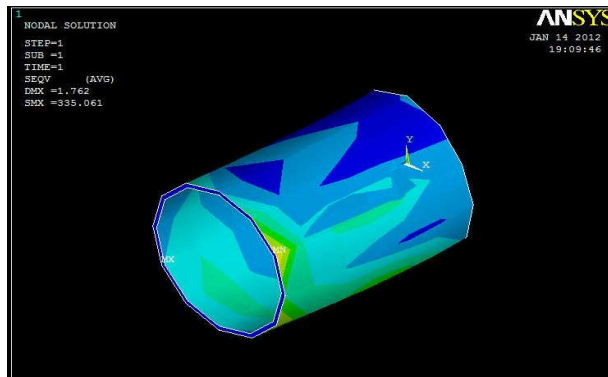

Figure no 7: Deformation plot of steel and GRE

Discussion Of Analysis Result  
 Analysis result

S.no	Material	Deformation mm	Stress N/mm <sup>2</sup>	Stiffness GPa	Tensile strength N/mm <sup>2</sup>
1.	GRE	1.72	335	10	1140
2.	STEEL	0.017	51	204	351

From the deformation plot and the stress plot it has been found that GR attains comparatively high deformation because of its low stiffness and comparatively high stress developed but it is well below its strength. It has been found in the vonmises plot that various red zone were scattered in steel but there was no trace of red zone in GRE stress plot.

14. Scheme Of Filament Winding Techniques

14.1 General lay out

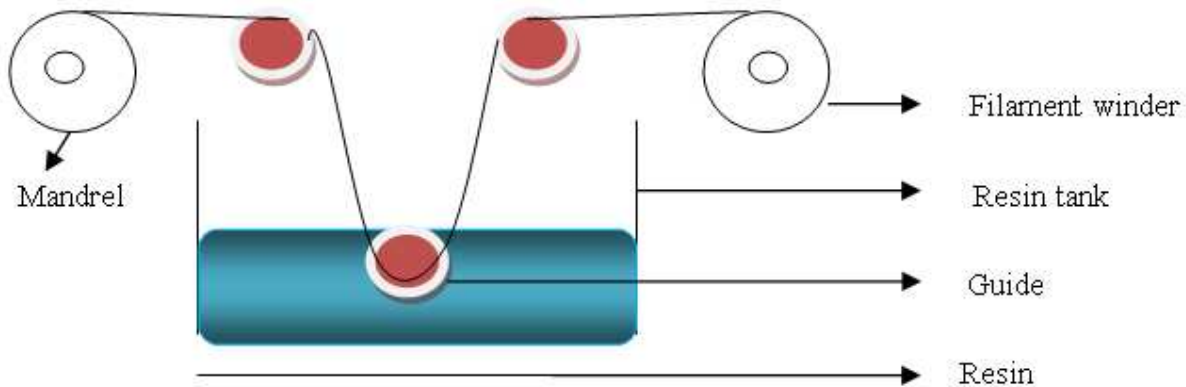

General lay out has been shown in the figure where it consists of filament winder, Resin tank Guide, Resin and mandrel. Fiber is being wound and impregnated on the resin through the guide and wound on the mandrel.

For the preparing the pipe for the As stated earlier reinforcement material used here is Glass fiber in the form of roving. Resin used here is Epoxy has been kept separately in the resin tank.Roving bundle was carefully mounted on the winding set up.

## 15. Manufacturing Process

### 15.1 Mandrel Preparation

Outer surface of the mandrel has been cleaned thoroughly using Diesel and ensured from free of rust. In case of Mild steel demold has been applied on the outer surface of the mandrel to facilitate easy removal of the part. In case of PVC Pipe has been Split into two half and fastened together by bolt to ensure easy removal of the part here applying demold is not necessary.

### 15.2 Filament preparation

Resin tank must be completely cleaned before pouring of resin into the tank. Prior to pouring of resin, Fibre tape must be fixed with the winder and as well as on the Guide .Proper tension must be maintained between the mandrel and resin tank to facilitate the proper winding into the mandrel.

### 15.3 Resin preparation

A 1 litre of epoxy solution is measured using measuring jar and poured at the resin tank. Then the 100ml of TETA solution is measured using the measuring jar poured to the resin tank. Then the mixture of both the epoxy and TETA are stirred well using the stirrer. Since pot life of the hardener is 30 min the process has to be carried out as soon as possible. Care must be taken while mixing resin and hardener. If hardener to resin ratio exceeds 1:10 blend will completely solidified. If ratio is less than 1:10 curing will get delayed.

### 15.4 Winding process

Before start winding care must be taken on the resin for its viscosity and tension of the fibre tape must be tested. After starting the machine carriage must be moved with prescribed feed rate and the angle. Winding must be stopped when desired thickness is achieved so that 3 mm.

### 15.5 Curing process

Curing is the process to dense the pipe with the desired hardness can be done by two processes open and oven curing.

### 15.6 Open curing

Curing can be affected by temperature and the pressure. If Curing is done at atmospheric temperature and pressure then it can be termed as open curing .Wound pipe let into atmospheric cooling for two hours or more. TETA facilitates the open curing at the atmospheric temperature.DDM can also be used in the curing process where it should be heated at 200 o c to liquefy the hardener and then it needed to be mixed with the resin.

### 15.7 Oven curing

Following fig shows the curing cycle of the Epoxy resin in turn applied for the GRE pipes In oven curing Wound pipe must be kept at the heating oven or furnace at around 200°c and allow it to cool at the atmospheric temperature. It will give the better result.

### 15.8 Curing cycle

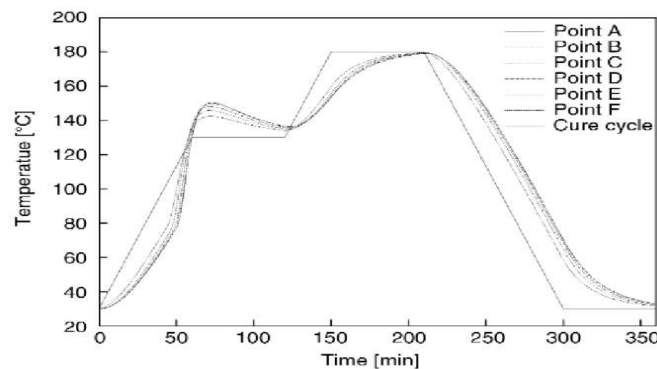

Filament winding



## 18. Results And Comparison

Name of the test	Hardness test	Compressive test	Leak test
Test result	62 HRC	9KN	No Trace of leak found

### 18.1 Comparative Statement

Description	PVC	GI	GRE
Hardness number	60 HRK	80 HRC	62HRC
Ultimate Load	0.2KN	10HRC	9HRC
Leak status	No trace	No trace	No trace

### 18.2 Compressive Test (ASTM D 695)

#### Apparatus required

- Compressive testing machine
- Specimen

#### Specimen:-Specification of the specimen

Internal diameter	:	Φ50mm
Wall thickness	:	3mm
Length of the pipe	:	150mm

### 18.3 Testing procedure

1. First specimen is placed laterally on the compressive testing machine table.
2. Dials are initially set to zero.
3. Hydraulic upper jaw is slowly let it contact with the surface of the specimen.
4. Load is being applied to the specimen.

## 19. Testing Procedure

Specimens opened bottom end is closed by means of the clamp and poured with the hydraulic oil top end also closed with the clamp and it has been kept for a period of one month and observation on any leak has been noted.

## 20. Conclusion

It has been concluded that GRE pipes is best suited for the application of conducting high pressure oil and gas, since it has more strength high hardness and more over high corrosion resistance .During the fracture test it has been observed that crack does not propagate through the either side of the pipe. Fracture first appears at the matrix and then propagates to the fiber.This property will retain the fluids inside even though fracture occurs.

## Bibliography

- [1] R.K.Bansal, “Fluid mechanics”, fifth edition, 1994, Lakhmi publikations pp387-482
- [2] R.K.Bansal, “Strength of materials”, fifth edition, 1994, Lakhmi publikations pp851-858
- [3] Daniel Gay, Suong V. Hoa, Stephen W. Tsai”Composite materials design and applications “2003, CRC press
- [4] Jones, R.M., “Mechanics of Composite Materials”, McGraw-Hill, Kogakusha Ltd., Tokyo, 1985 pp 55-102
- [5] F.L.Matthews & R.D.Rawlings, “Composite Materials, Engineering and Sciences ”, Chapman& hall, London, 1994.