

Technical Disclosure Commons

Defensive Publications Series

June 13, 2017

Tool-less Double Sided Board Retainer

Minh H. Nguyen

Hewlett Packard Enterprise

David A. Selvidge

Hewlett Packard Enterprise

Follow this and additional works at: http://www.tdcommons.org/dpubs_series

Recommended Citation

Nguyen, Minh H. and Selvidge, David A., "Tool-less Double Sided Board Retainer", Technical Disclosure Commons, (June 13, 2017)
http://www.tdcommons.org/dpubs_series/550



This work is licensed under a [Creative Commons Attribution 4.0 License](https://creativecommons.org/licenses/by/4.0/).

This Article is brought to you for free and open access by Technical Disclosure Commons. It has been accepted for inclusion in Defensive Publications Series by an authorized administrator of Technical Disclosure Commons.

Tool-less Double Sided Board Retainer

Abstract: Disclosed is a retainer that allows retention of two daughter circuit boards on either side of a main circuit board. The retention device allows the daughter boards to align with each other, minimizing the space required on the main board.

This disclosure relates to the field of mechanical mounting of circuit boards.

In some electronic devices, such as for example server computers, it is advantageous to minimize the area and volume occupied by the circuit boards. Doing so allows the server to be made smaller and/or more circuitry to be included in a server of a same size.

Many such devices install daughter cards on opposite sides of a main board. This is done by running a screw through the daughter card onto a standoff located at a first position on the main board. Because the opposite-side standoff cannot be installed in the same space on the main board as the first standoff, it is installed at a second position on the main board which is offset from the first position. This disadvantageously causes the main board to grow by the same distance as the offset. In some situations, this can prevent the main board from fitting into the available space.

According to the present disclosure, and as understood with reference to the Figure, a double-sided retainer assembly 10 allows retention of two daughter circuit boards 20A, 20B on either side of a main circuit board 30. The retainer assembly 10 allows the daughter boards 20A, 20B to align with each other, minimizing the space required on the main board 30.

The retainer assembly 10 consists of two main bodies 40A, 40B; two side retainers 50A, 50B; and a screw 60. The assembly 10 then gets installed onto the main board 30 by inserting it, then sliding it to latch in a hole on the board that has a specific shape. Once installed, the retainer assembly 10 can independently retain the two daughter cards 20A, 20B on either side of the main board 30. In some examples, the side retainer part 50A, 50B is rotated (using a finger or a tool) to attach/remove the daughter board via a soft-snap lock feature 55.

The disclosed technique advantageously reduces the area on the main board which is allocated to the mounting of daughter boards, and enables tool-less installation of both the retainer assembly to the main board, and daughter boards to the retainer assembly.

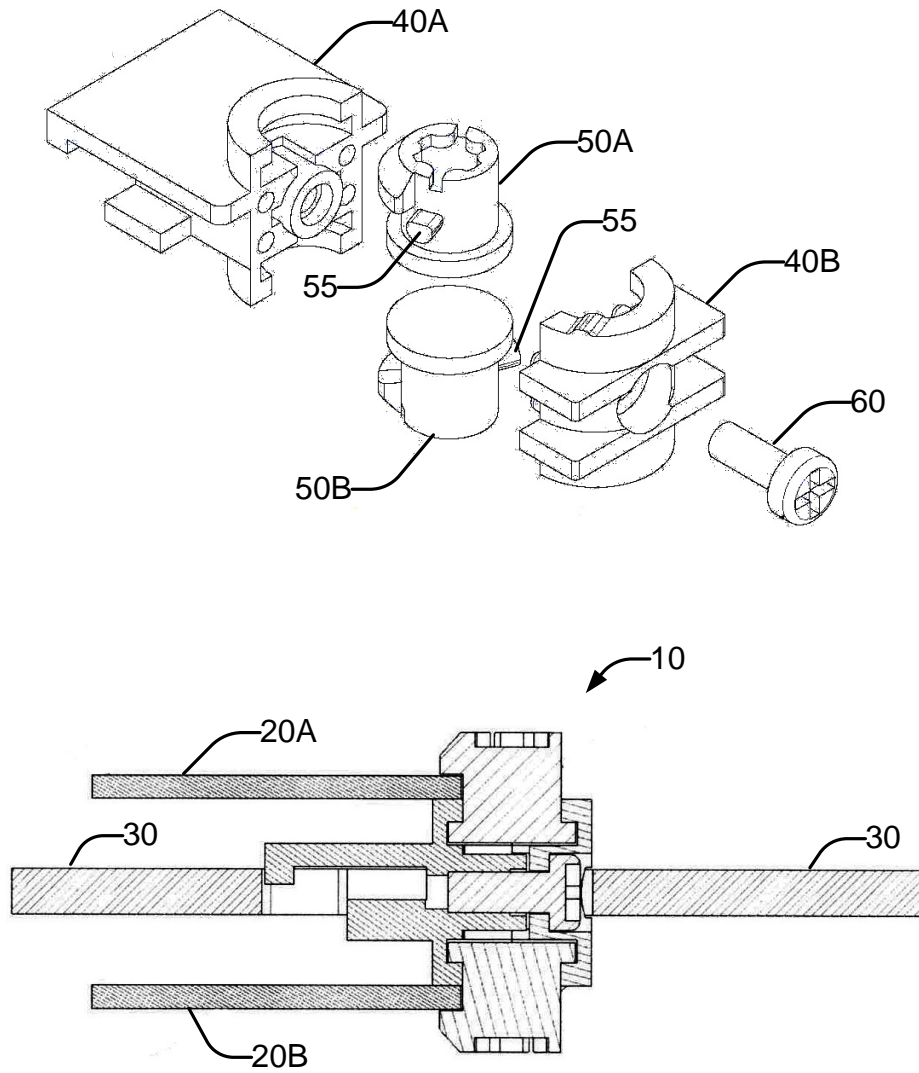

Disclosed by Minh H. Nguyen and David A. Selvidge, Hewlett Packard Enterprise