

Technical Disclosure Commons

Defensive Publications Series

May 01, 2017

Noise Cancellation For Tv Output

Brant Candelore

Mike Nejat

Peter Shintani

Follow this and additional works at: http://www.tdcommons.org/dpubs_series

Recommended Citation

Candelore, Brant; Nejat, Mike; and Shintani, Peter, "Noise Cancellation For Tv Output", Technical Disclosure Commons, (May 01, 2017)

http://www.tdcommons.org/dpubs_series/484



This work is licensed under a [Creative Commons Attribution 4.0 License](https://creativecommons.org/licenses/by/4.0/).

This Article is brought to you for free and open access by Technical Disclosure Commons. It has been accepted for inclusion in Defensive Publications Series by an authorized administrator of Technical Disclosure Commons.

NOISE CANCELLATION FOR TV OUTPUT

IPD #201605709

ABSTRACT

A system and method are disclosed to cancel noise other than speech in a TV. The method uses technology used in noise cancelling headphones to cancel noise delivered with dialogue through the TV's audio output. The system includes electronics, placed between the TV's audio signal and the speakers, to sense the audio content and generate a "fingerprint" of the noise, noting the frequency and amplitude of the incoming wave. The system then creates a new wave that is 180 degrees out of phase with the waves associated with the noise, to cancel the noise out. The cancelling feature may be used for content rendered (decoded) by the TV itself or audio input to the TV from HDMI, analog audio in, etc. The system may apply the filtering function very selectively to automatically highlight voice frequencies.

BACKGROUND

A problem with the hearing impaired is simple speech comprehension. Most shows have music or suspenseful music playing while people are talking in certain scenes. The hearing impaired may find it difficult to comprehend speech in such scenes. Previous solutions include using graphic equalizers to boost frequencies in the voice range while lowering the volume outside that range. However, not all frequencies are suppressed and the method is not automatic.

DESCRIPTION

A system and method are disclosed to cancel noise other than speech in a TV. The method uses technology used in noise cancelling headphones to cancel noise delivered with dialogue through the TV's audio output. The system includes electronics, placed between the TV's audio signal and the speakers, to sense the audio content and generate a "fingerprint" of the noise,

noting the frequency and amplitude of the incoming wave. The system then creates a new wave that is 180 degrees out of phase with the waves associated with the noise, to cancel the noise out.

The cancelling feature may be used for content rendered (decoded) by the TV itself or audio input to the TV from HDMI, analog audio in, etc. The system may apply the filtering function very selectively to automatically highlight voice frequencies.

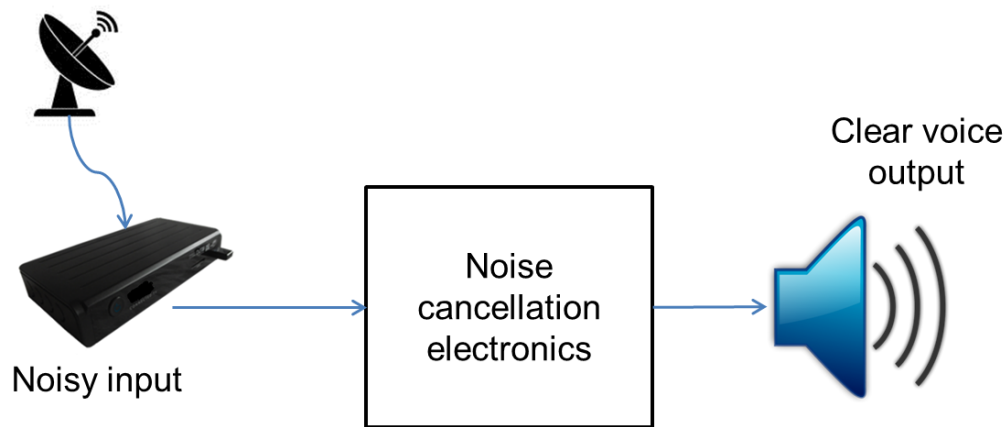

FIG. 1: Method of using noise cancellation on TV to help the hearing impaired

Advantages of the system and method include better user experience due to clear voice rendition, especially for the hearing impaired.