

Technical Disclosure Commons

Defensive Publications Series

February 16, 2017

A new cable clip module with moveable cable clip

Chih-Chang Chen
Hewlett Packard Enterprise

Ken Lee
Hewlett Packard Enterprise

Albert Liu
Hewlett Packard Enterprise

Kevin Chang
Hewlett Packard Enterprise

Shane Chen
Hewlett Packard Enterprise

See next page for additional authors

Follow this and additional works at: http://www.tdcommons.org/dpubs_series

Recommended Citation

Chen, Chih-Chang; Lee, Ken; Liu, Albert; Chang, Kevin; Chen, Shane; Chen, Verna; Cheng, August; Fang, Ben; Ho, Passor; Huang, Chun-Pin; Huang, Jay; Shih, Che-Chih; Lee, Dan; and Lo, Hellen, "A new cable clip module with moveable cable clip", Technical Disclosure Commons, (February 16, 2017)
http://www.tdcommons.org/dpubs_series/394



This work is licensed under a [Creative Commons Attribution 4.0 License](https://creativecommons.org/licenses/by/4.0/).

This Article is brought to you for free and open access by Technical Disclosure Commons. It has been accepted for inclusion in Defensive Publications Series by an authorized administrator of Technical Disclosure Commons.

Inventor(s)

Chih-Chang Chen, Ken Lee, Albert Liu, Kevin Chang, Shane Chen, Verna Chen, August Cheng, Ben Fang, Passor Ho, Chun-Pin Huang, Jay Huang, Che-Chih Shih, Dan Lee, and Hellen Lo

A new cable clip module with moveable cable clip

Abstract

For a server system, we would have many kinds of configurations for customer's different application. Some configurations like 2.5" / 3.5" HDD or different length PSU might have different PCBA, cable, mechanical part and cable clip in the chassis. It will have the part's maintenance and inventory cost on these parts for different configuration. So if we could use the same part at different configuration, it will reduce our cost. So we propose a new cable clip module with moveable cable clip to let the cable routing more flexible by moving the location of the cable clip. By using this cable clip module, we could use the same cable for different configuration like different length PSU and different size HDD. And we also could use the cable clip module at the same location in the chassis for these configurations.

Problem Description

For some configurations with different size of commodity like HDD and PSU, we might need to create different PCBA, mechanical part and cable for them. And we also need to define different location of cable clip for its cable routing. They all will increase our part's maintenance and inventory cost.

Previous Solutions

Please refer to Figure1 about the solution for different configuration for different size commodity like HDD before. We will have different PCBA, PCBA 2 and PCBA 3 and different cable, cable 1 and cable 2. PCBA2/3, cable clip 1 and cable clip2 also will have different location in the chassis.

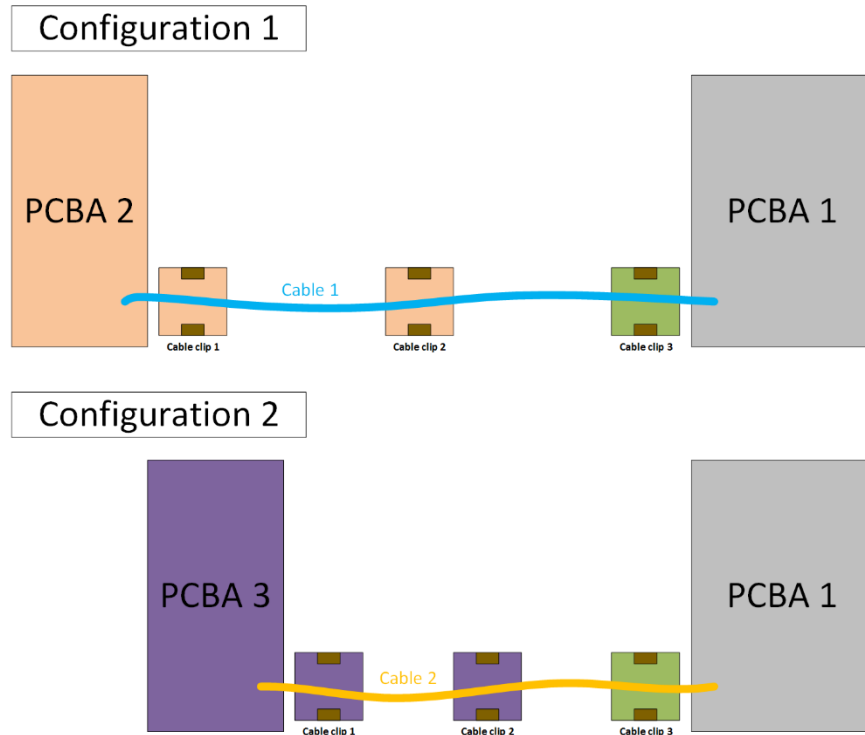

Figure 1 - The solution for different configuration for different size commodity like HDD before

Invention Description

Please refer to below about the cable clip module we create. The cable clip module contains three parts, a cable clip, a spring and a track.

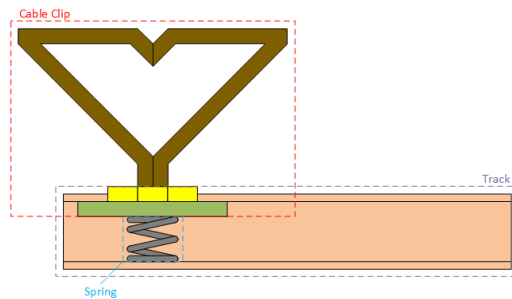

Figure 2 – The new moveable cable clip module

We could fix the cable easily with the cable clip as figure 3. By the cable clip with spring, we could move and lock in the track. By the track, we could let the cable clip fix on two or more specific location. Please refer to figure 4 about the example of the cable clip lock at location 1 or location 2.

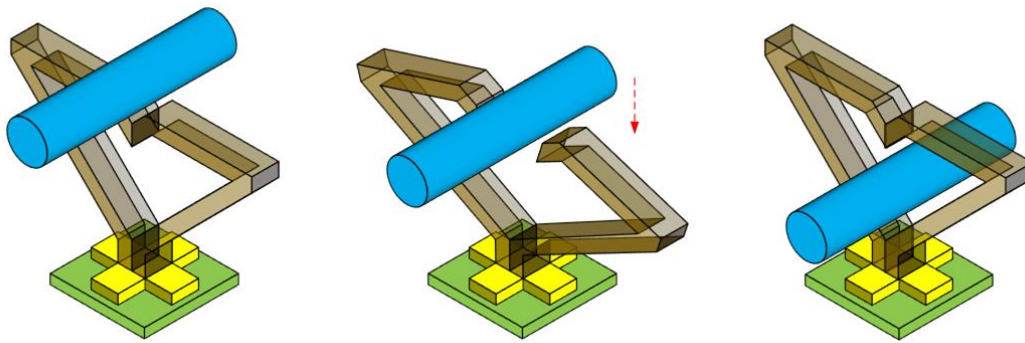

Figure 3 – How to fix the cable at the cable clip

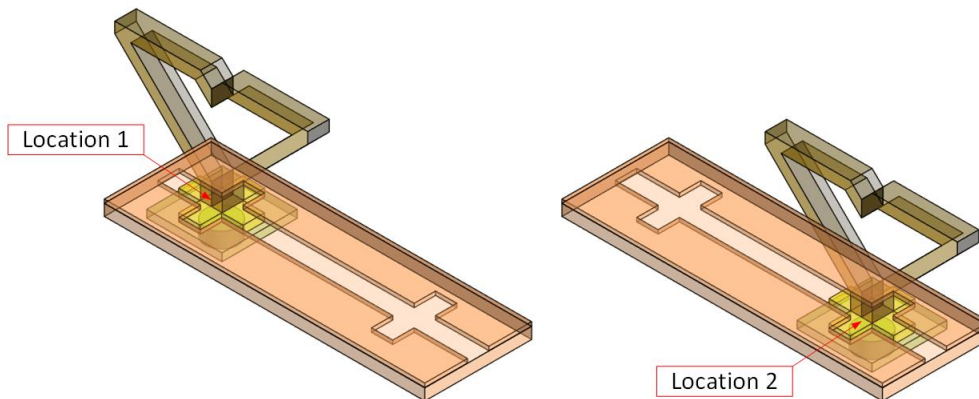

Figure 4 – The cable clip lock at Location 1 or Location 2

Please refer to figure 5 about how the cable clip module works. (1) means the initial location. The cable clip with spring is locked at location 1 in the track. Then we press the cable clip with spring to let yellow area of the cable clip under the track cover. So the cable clip with spring is un-lock from location 1. Then we could move forward the cable clip with spring from location 1 to location 2 like (3). When the cable clip with spring is arriving at location 2 like (4), the spring will let the cable clip lock at location 2 like (5).

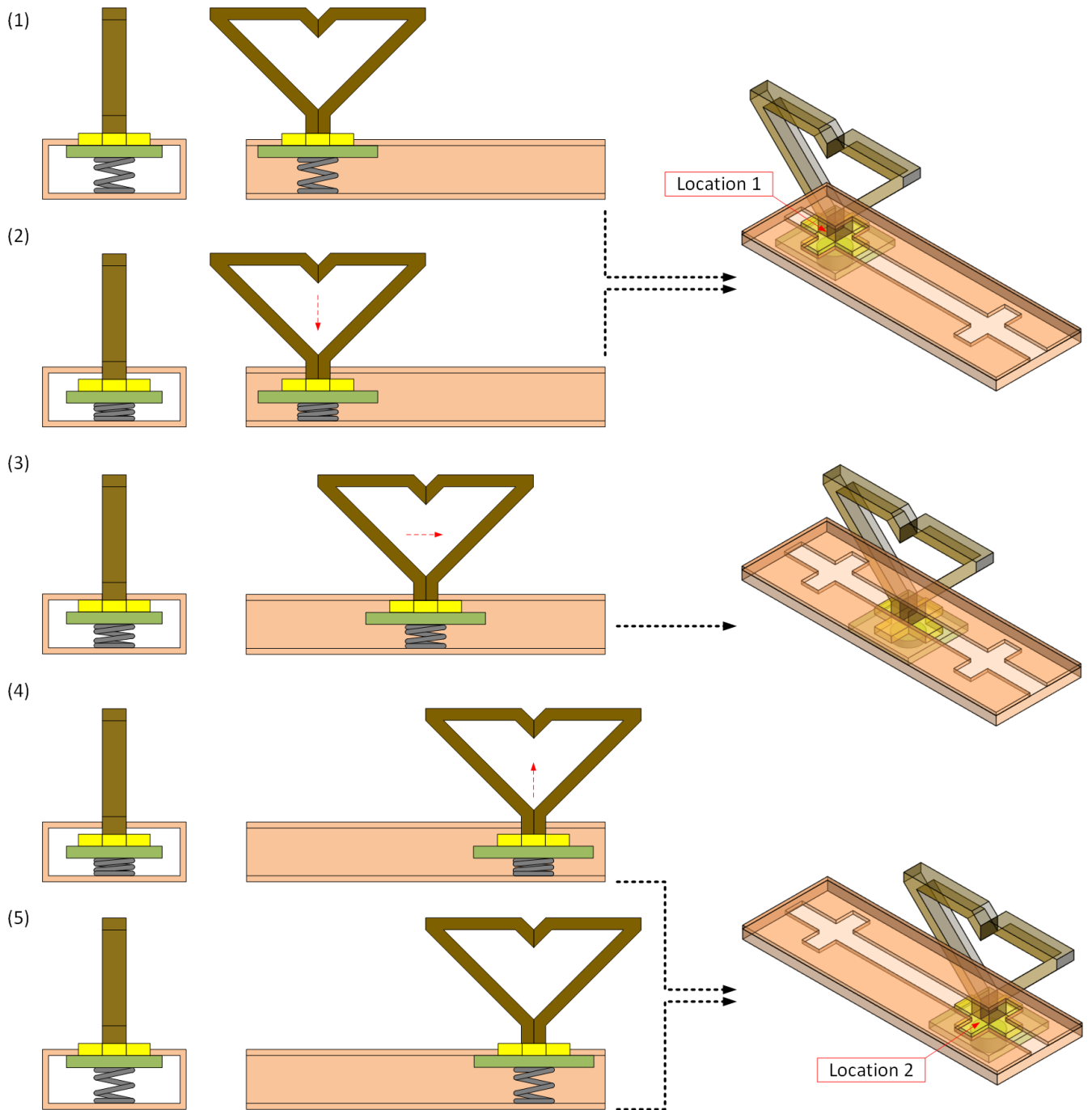

Figure 5 – The detail movement of the cable clip with spring from location 1 to location 2

Please refer to figure 6 about the example diagram for different length PSU configuration. When we use cable clip module 1 for PSU1 (Length=A) configuration, we can move the cable clip in cable clip module 1 to Location 3. And when we use for cable clip module 1 for PSU2 (Length=B) configuration, we can move the cable clip in the cable clip module 1 to location 4. So

we could use the same cable, Cable 3 for PSU1 or PSU2 configuration. We also fix cable clip module 1 at the same location in the chassis for different length PSU configuration in the chassis.

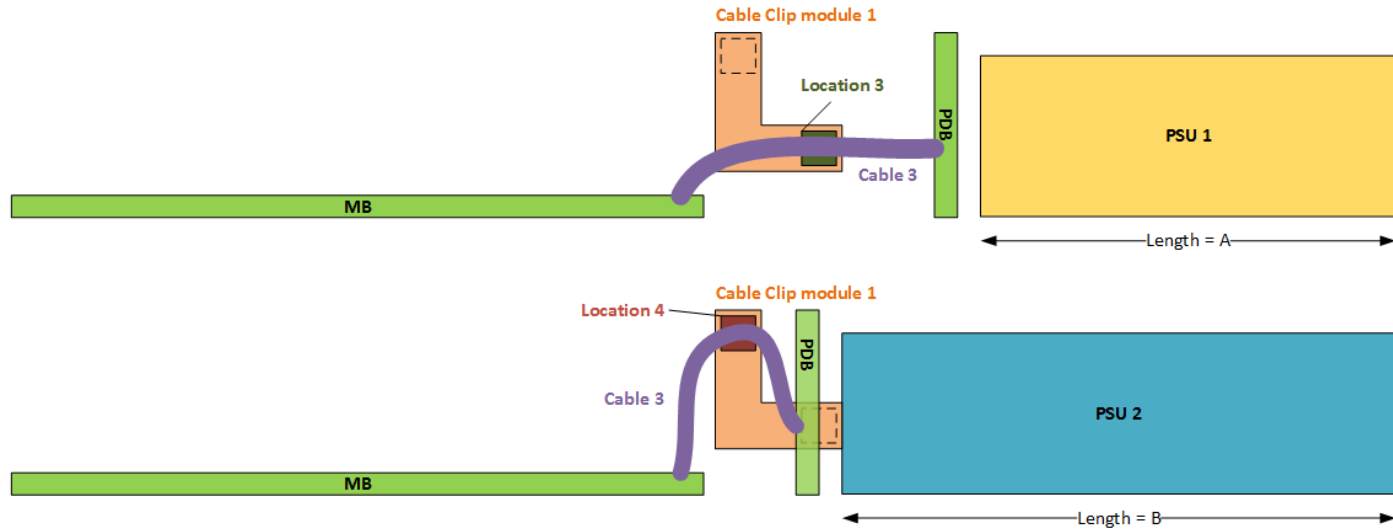

Figure 6 – The example about the cable clip module for different length PSU configuration.

Please refer to figure 7 about the example diagram for 1U rack server with 2.5" and 3.5" HDD configuration. When we use Cable clip module 2 and Cable clip module 3 for 2.5" HDD configuration, we can move the cable clip in cable clip module 2 to left fixed location and move the cable clip in cable clip module 3 to lower fixed location. And when we use them for 3.5" HDD configuration, we can move the cable clip in the cable clip module 2 to right fixed location and move the cable clip in the cable clip module 3 to higher fixed location. So we could use the same cable, Cable 4 for 2.5" or 3.5" HDD configuration. We also can fix cable clip module 2 and cable clip module 4 at the same location on the two different HDD configuration in the chassis.

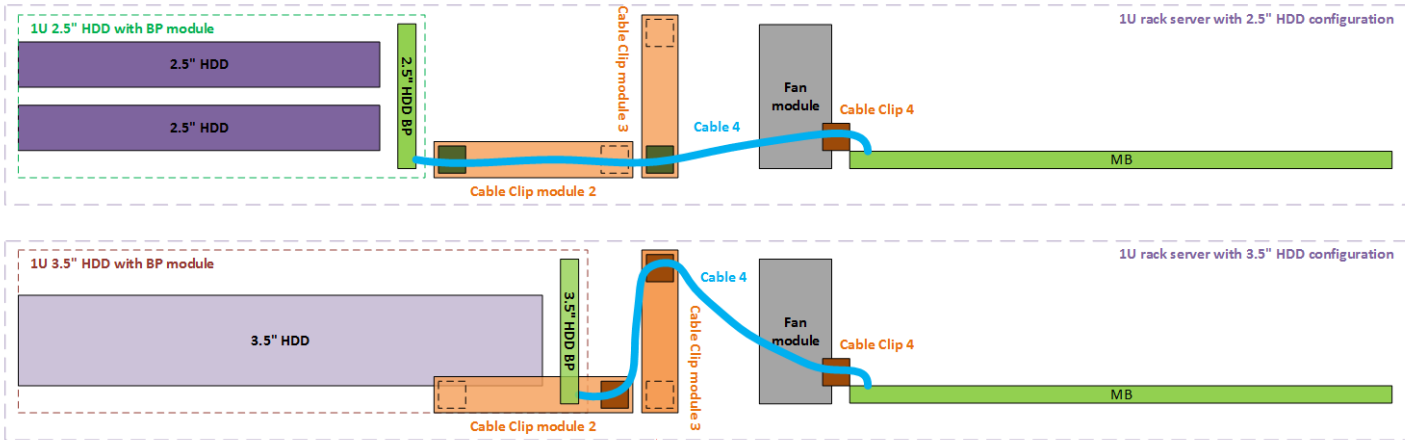

Figure 7 – The example about the cable clip modules on 1U rack server with 2.5\"/>

Based on this concept, we could let cable routing more flexible by using the cable clip module. So we could use the same cable and the same location of cable clip module for different configuration.

Advantages

We create a moveable cable clip in the new cable clip module that could let the cable routing more flexible by moving the location of the cable clip. By using this cable clip module, we could use the same cable for different configuration like different length PSU and different size HDD. And we also could use the cable clip module at the same location in the chassis for these configurations. We could decrease the base BOM configuration and then decrease maintenance and inventory cost by using this moveable cable clip module.

Disclosed by Chih-Chiang Chen, Ken Lee, Albert Liu, Kevin Chang, Shane Chen, Verna Chen, August Cheng, Ben Fang, Passor Ho, Chun-Pin Huang, Jay Huang, Che-Chih Shih, Dan Lee, Hellen Lo, Hewlett Packard Enterprise