

Journal of Environment and Earth Science
ISSN 2224-3216 (Paper) ISSN 2225-0948 (Online)
Vol 2, No.1, 2012

www.iiste.org

A Case Study on Blowout and Its Control in Krishna-Godavari (KG) Basin, East Coast of India: Safety and Environmental Perspective

C.K. Jain^{1*}, S.S. Yerramilli², R.C. Yerramilli²

1. Ex-Professor, COE, University of Petroleum and Energy Studies, Dehradun, India.
2. Department of Geotechnology, Delft University of Technology, Delft, Netherlands.

* E-mail of the corresponding author: sanjaysurya@gmail.com

Abstract

Major blowouts in Krishna-Godavari (KG) basin have led to number of risks related to loss of human lives, environmental pollution and loss of material assets. The geological complexity of the field and the presence of over pressure zones, mainly in East Godavari sub-basin, particularly in the wells at Amalapuram, Razole and Narsapur have led to major disasters in the past years. Therefore, an attempt has been made to identify the most possible causes of these disasters and to propose a safe drilling procedure to prevent these disasters in the upcoming ventures. This paper highlights the case study of a blowout occurred in KG basin in East Coast of India. An analysis of the blowout was carried out which includes well configuration and details, mechanical equipment used for controlling the blowout, firefighting procedures, financial losses incurred. The effect of exploration and production of oil and gas on the property and environment were also discussed. Efficient drilling and safety procedures were recommended to prevent further blowouts in future. The recommendations presented will be of utmost importance for oil and gas operators and service companies to take necessary steps in future drilling operations in over pressured formations of KG basin to prevent loss to personnel, property and damage to the environment.

Keywords: Blowout, Overpressures, Firefighting, Safety Procedures, Environmental Impact.

1. Introduction

Exploration of energy resources has played an important role in generating and sustaining individual development and economic growth. The consequences (Anon, 1995) of increased use of these hydrocarbons resulted in environmental degradation. There are other potential environmental hazards caused by these operations including the danger of "blowout", which was the case in the present study. The control of subsurface pressure (Danenberger, 1993) is of utmost importance in planning drilling and conducting onshore or offshore drilling operations. Improper well control procedures lead to uncontrolled flow of hydrocarbons to the surface which is referred to as blowout. Blowouts are most spectacular, expensive and feared operational hazards which results in costly delays in drilling programs and loss to human life, property and damage to the environment. The benefits (Dawson, 1966) derived from an effective safety program are large in terms of tangibles and intangibles. Good safety practices have to be recognized by operators and drilling contractors. It is the duty of the personnel working in the oil gas sector, to protect the environment and at the same time pursue the goal of economic development. One way to achieve this is through sustainable technology and development.

2. Geology of KG Basin

The KG basin (DGH, 2010) is a proven petroliferous pericratonic basin formed on the continental passive margin located on the east coast of India (**Figure 1**). The basin contains about 5 km thick sediments with several cycles of deposition, ranging from Late Carboniferous to Pleistocene age. The sedimentary sequence (Gupta, 2006) of KG Basin ranges from Permian-to-Recent. The Paleocene-Eocene sediment

package was deposited over the floor of the trap formed by the Deccan volcanism during late Cretaceous. The Precambrian metamorphic basement consists of gneisses, quartzites, charnokite, and khondalite. The sedimentary tract (Bastia, 2007) contains a vast range of geologic settings, such as costal basin, delta, shelf-slope apron, deep-sea channel, and deep water fan complex. The well site where the blowout occurred was about 7 km from Amalapuram. It is situated in the sub-basin of East Godavari, which belongs to Paleozoic era.

The basin was formed following the rifting along eastern continental margin in early Mesozoic. Formation of the series of horst and grabens cascading down towards the ocean led to different reservoir compartments separated by steeply dipping faults. In the Tertiary, the area became structurally deformed by numerous sets of growth faults and related features. In deltas as the sediment is loose and due to large sediment input into the basin and slope stability numerous growth faults develop. Tilted fault blocks, (Rao, 2001) growth faults, and related rollover anticlines provide the structural traps. In deltas as the sedimentation rate is high, the water initially present in the pore space cannot escape out resulting in over pressured formations. The overpressures are encountered mainly in the East Godavari sub-basin, particularly in the wells drilled at Amalapuram, Narsapur, and Razole and in the adjoining offshore areas. The formation pressures have been found to be two times larger than the normal hydrostatic pressure. The site was surrounded by paddy fields, coconut plantations and irrigation canals of the Godavari River providing a beautiful landscape in normal times.

3. Well Details/Event Summary

A raging blowout (Bhaskar, 2005) occurred in an exploratory well in the East Godavari District of Andhra Pradesh in Jan'95. The well was spudded in Sep'94. The bit sizes and the casing details of the well were given in (Table 1) and the well configuration is shown in (Figure 2). The drilling progressed with 8.5 inch bit and with a drilling mud specific gravity of 1.3 ± 0.1 . The bit had stuck at the depth of ≈ 2727 m MD which was confirmed by conducting a stretch test. The stuck up might be due to many reasons which were discussed in the coming sections. An attempt has been made to retrieve the drill rods by unscrewing, which was successful. Unfortunately, they were unable to retrieve the drill bit and drill collars and were left in the well bore. It was reported no kick off pressure recorded until this stage.

As alleged, in the evening, uncontrolled flow of gas to surface at high pressures led to a blowout. The spewing gas caught fire immediately. The remaining pipes inside the bore were thrown out by the enormous pressure of the gas. The derrick and the surrounding equipment were gutted after the blowout. The pressure (Jain, 1995) of the gas was estimated around 281.2 ± 0.5 kg/cm². The sound resembled like a rocket engine and the level was so high that none can hear anything up to 700 m distance from the site, necessitated the use of ear plugs. In the night, the intensity of the light caused by the flame was so high that it is visible up to a distance of more than 2 km from the well site. The gas flames (Pantulu, Satyanarayana, 2005) were about 200 feet high with temperature shooting to more than 50°C. About 1 million m³/day of gas spewed out with a deafening sound as shown in (Figure 3).

4. Safety Action Plan

With raging flames of high magnitude and panic spread over the villages in the vicinity, (Jain 1995) nearly 6000 families evacuated their houses. This was in addition to the many other problems. The action plan was executed immediately without any loss of time. Therefore a prompt and immediate action was taken by the company personnel to,

- Combat the flame.
- Rehabilitate the villagers (evacuation of villagers) and setting relief camps. The families who left their houses were accommodated in relief camps and were provided food through local administration. Nearly 225 families were in relief camps till the well was capped.

- Discussion with local administration, government and public for their coordination and help with the safety rescue personnel.
- Digging of water storage pits for creating a water umbrella over the flame and cleaning the debris and retrieving the casings etc., from the well and well site.
- Mobilize the firefighting equipment from the well site.

5. Blowout Control Operation

5.1 Mechanical Equipment

- Six pumps of 20,000 gal/min total capacity were used for spraying of water and to create a water umbrella over the flame to reduce the temperature of the flame and surroundings for approach of the safety rescue personnel and for clearing the debris at the site. To prevent the damage of the pumps, they were placed in the well site. A schematic of the pumps arrangement used for combating the blowout is shown in **(Figure 4)**. The details of the pumps used for pumping the water are given in **(Table 2)**.
- Water monitors were bought for monitoring the level of water in the storage pits. Initially four monitors of 0.1016 ± 0.01 m sizes were used and later on four more monitors of 0.023 ± 0.01 m size were received from USA in first week of Feb'95.
- Athey wagon **(Figure 5)** was employed (Kelly, 1993) to clear the debris at the well site so that it was easier for the safety rescue personnel to reach within 20 m radius of the blowout area.

5.2 Procedures (Success/Failures)

- Two huge water storage pits of 20000 m³ total capacity were created. Fortunately an irrigation canal was present at about 500 m from the site. Water was pumped from irrigation canal to the storage pits. Water was sprayed onto the flame to reduce the intensity of the flame for further operations.
- Drums of plastic explosives of each approx... 200 kg were dispersed over the flame, to suck up all the oxygen and to extinguish the fire. But many attempts failed. In another attempt, approx... 400 kg of plastic explosive was dispersed onto the flame with the help of Athey wagon and the finally the fire was extinguished. This brought much needed relief to the crew and experts at the well site.
- In the same month, the final capping operation such as installation of new wellhead and blowout preventer's was successful with the help of water umbrella of 98.4 m³/min water spray.
- The surroundings were cleaned with the use of Athey wagon, bulldozer and a crane with hook. A relief well (Wright, 1993) from a distance of 1.5 km from the site of blowout was drilled to connect to the bottom of the blowout well. High density drilling mud was pumped to control the flow of gas from the reservoir into the well bore. The choice of spraying foamy fire retardant chemicals was not tried to put off the fire.

6. Consequences

6.1 Material/Financial Loss

- The drilling equipment's of the company of worth approx... US\$ 4 million (Shrivastava, 1995) was destroyed. No estimate was made for mobilization cost of equipment and other relief operations. Uncontrolled flow of gas to the surface in the form of blowout at a rate of 1 million m³ per day costing around US\$ 34,000 per day.

- About 280 hectares of paddy fields (Jain 1995) and 470 hectares of coconut trees were affected by the rising flame. A total compensation of US\$ 0.2 million for paddy fields and US\$ 42 per coconut tree were paid to the owners. Seedlings at the cost of US\$ 90 per hectare were compensated.
- For the relief work US\$ 76,000 was paid by Jan'95 and US\$ 96,000 was spent till Feb'95 on relief camps. Four experts (Sarma, 2005) from Boots and Coots Ltd based in Houston were engaged in fire fighting operation initially, US\$ 3,000 per day was paid to American safety rescue team and later US\$ 10,000 per day was paid in the second term. A coordination team was set up to work round the clock.

6.2 Environmental Damage

This incident resulted in serious environmental damage and also damage to flora and fauna. The paddy fields, coconut groves and prawn farms within 2 km radius of the site were damaged due to enormous heat of the rising flame. Cultivation of paddy was possible in next season but palm trees were damaged permanently. After 1993 blowout an unknown virus infected the brackish water required for the growth of prawns and resulted in loss of two successive growths. The houses in the vicinity of blowout were damaged due to cracks that developed because of high intensity of sound disturbed the sleep of the people. The constant heat and light also affected the life of animals and birds.

7. Causes of Blowout in KG Basin

The causes of blowouts were divided into two categories. One, a few possible causes of blowouts (Works, 1944), fortunately these are few in number and their probability of occurrence is slight. On the other hand blowouts can also occur unpredictably that place stress upon the control equipment in excess of even the most conservative allowance for factors of safety. In this section, importance has been given to the second type of causes rather than to the first type. In the second type, emphasis is given to the causes relevant to the stuck up of drill string which lead to blowout in KG basin. Stuck up of drill pipe may be due to various reasons (Blok, 2010) as the subsurface rock layers are much diversified in their nature and composition.

- In plastic formations such as salt dome, if the pressure caused by the drilling mud is lower than the formation pressure, the formation deforms causing the hole to collapse as salt is visco-elastic in nature. Reaction of clay minerals with the drilling mud causes swelling and sloughing that cause well bore problems and result is pipe stuck up.
- The other type of stuck up which cause due to differential pressure. This occurs in open hole when the pipe comes in contact with a permeable formation having a pore pressure much less than the pressure caused by the drilling fluid. In this case the string is held in place due to the differential pressure. This situation can be recognized by increased over pull on connections due to increase in frictional forces in the well bore. The above situation was encountered in KG basin and was confirmed by stretch test as described in the event summary.
- As KG basin contains huge gas resources, drilling through these gas reservoirs is of high risk. The main reason for blowout in drilling gas reservoirs too fast is (Adams, 1990) due to fact that that the gas contained in the formation being drilled becomes mixed with the drilling mud as the bit penetrates the gas bearing strata thus causes the drilling mud to become gas cut and lightened to such an extent that it will not overcome the formation pressure.

8. Impact of Exploration and Production Activity on Environment

Oil and gas exploration and production require large infrastructure, supply of necessary materials with constant influx of personnel that make the well sites and near well site area prone to environmental degradation with time (Madduri, 2003). In this section more emphasis is given to the environmental damage caused by drilling operations.

8.1 Gas Emissions

Oil and gas blowouts result in emission of large quantities of harmful gases such as sulphur dioxide, carbon monoxide, hydrogen sulphide and other oxides of nitrogen and as well as particulates containing burnt hydrocarbons and metals that are potentially harmful to human health and vegetation. The emissions from drilling activity and their relative contribution to different types of environmental damage (Madduri, 2003) were shown in **(Figure 6)**. The oxides of sulphur and nitrogen lead to decline in growth of plant and animal life and especially nitrogen oxides can affect the respiratory system in living organisms and humans. Carbon dioxide is a greenhouse gas which cause global warming.

8.2 Noise from Drilling Operation

Out of entire oil and gas exploration activity, drilling phase produces more noise pollution. Noise affects not only humans but also wildlife. The sounds produced from drilling operation can have a serious impact on living creatures, depending on the closeness to the well site. The impact of drilling operation is of varying magnitude both on socio-economic and environmental parameters. However, the threshold also varies from place to place.

8.3 Hydrological Impact/Soil Ecosystem

The important concern in drilling from hydrological perspective is that the degradation of land, water and air near the drill site. Major sources of pollution from drilling activity that cause hydrological and affect the quality of soils are chemicals such as bentonite, barite, diesel, mercury, cadmium (Candler, 1992), arsenic formaldehyde and heavy metals in drilling fluids. Most of the drilling muds are very toxic. These pollutants cause contamination of ground and surface waters. The mud pits used in drilling operation can affect the ground water and ecology of the surroundings by the process of lateral migration through fractures present in the subsurface. Two main significant impacts of drilling activity to soil ecosystem are invasion of drilling mud and chemicals into surrounding formations, Compaction of pores due to removal of oil and gas leads to subsidence in the area.

8.3 Flora and Fauna

The interruption of the ecological balance due to drilling operation occurs through surface discharge of pollutants affecting the environment. Mainly damage is caused due to construction of roads, pipelines, establishment of drilling site, support infrastructure etc. The loss of vegetation in the area affects nutrient cycles, deteriorates soil quality and reduces the availability of habitat for wild life. Habitat damage also includes vegetation or soil removal, erosional topographies, sedimentation, and hydrology. The changes in the abundance and distribution of certain wildlife species can have significant effect on the livelihood of indigenous people living in that area.

9. Recommended/Proposed Safety Procedures

- As over-pressures have been encountered in the East Godavari sub-basin it is advisable to have a detailed study of the geological setting of the basin in terms of presence and degree of over pressures and different pressure regimes in different parts of the reservoir leads to compartmentalization of the reservoir. Necessary steps should be taken by reviewing the history of blowouts occurred previously in this region at Lingaboyanacheral in 1979, Komarada in March 1993 and East Godavari District in March 1993.
- Various signs (Ellis, 1981) of kick such as increase in the ROP caused due to reduced differential pressure between mud pressure and the pore pressure, loss of circulation, pressure decrease in well bore due to gas cut mud, increase in return flow rate and increase in pit level must be monitored

constantly and the information should be passed on to the crew working at the well site. Training must be imparted to the crew to avoid occurrence or at least to limit or lessen the ferocity.

- The rig and equipment's used for drilling should be well adapted to the performance of the task required. The equipment's should be routinely tested for any defects and should be rectified before using at the well site.
- Wells (Yerramilli, 2007) must be designed carefully with casing seats selected scientifically and the location should be checked for any weak formations. The rough depth estimate of high pressure zones should be known from exploration geologists before drilling a well. The proximity of high pressure formations should be known before hand through ROP to avoid the possibility of formation breakdown.
- The of various reservoir and well parameters such as pore pressure, bottom-hole pressure to be maintained and initial pumping pressure and mud density should be calculated while killing the well. Now a days, as the world is technologically far ahead, implementation of new exploration and drilling technologies such as high resolution 3D seismic, cyber rigs should be used for efficient development of oil and gas fields.
- Last but not the least, consciousness of the personnel working at the well site with sufficient training in well control procedures can decrease the intensity of the blowout.

10. Conclusions

- Well control procedures and training are very important aspects of planning these well operations with well control as a primary consideration, with emphasis on kick prevention and minimization of kick size (early detection) in order to prevent material and financial losses and damage to the environment.
- The failure to reduce drilling blowout occurrence rates is largely attributable to difficulties in drilling through shallow gas sands as learnt from this case study. The prevention of blowout lies in the hands of the operators and their personnel. The combination of blowout consciousness management, efficient and reliable equipment and well educated and trained drilling crews are the best options for blowout prevention in order to avoid environmental damage.
- It was a great credit to the company for making arrangement within a period of 3 days only, which was possible only by the personnel working round the clock with determination. Personnel of the company were appreciated for the relief work done. Hence drilling of future wells in that area was permitted by the public.
- An in depth knowledge of the geological setting of the East Godavari sub-basin is required before drilling wells in shallow or deep gas reservoirs in this area.

References

- Adams, N. J, and Kuhlman, L. G., (1990) Case History Analyses of Shallow Gas Blowouts. SPE 19917, Feb 27-Mar 2, IADC/SPE Drilling Conference, Houston, TX, USA.
- Anon, (1995), The Oil industry Experience Technology Corporation and Capacity Building Contribution to Agenda 21. IPIECA/UNEP, London.
- Bastia, R, Nayak, P, Singh, P, (2006), Shelf Delta to Deepwater Basin: A Depositional Model for Krishna-Godavari Basin. AAPG International Conference, Perth, West Australia, Nov 5-8, 2006.
- Bhaskar, B.V.S, (2005), Blowout Occurs in ONGC Exploratory Well, no casualties. [Online] Available: <http://www.hindu.com/2005/09/09/stories/2005090919750100.htm> (Sep 9, 2005)
- Blok, G., (2010), Well Engineering Handbook, Chapter 10: Stuck Up and Fishing. Internal Course Notes, Delft University of Technology, Delft, Netherlands.

Candler, J. E (1992), Source of Mercury and Cadmium in Offshore Drilling Discharges. SPE Drilling Engineering Journal 7, 279.

Danenberger, E.P, (1993), Outer Continental Shelf Drilling Blowouts 1971-1991. OTC 7248, 25th Annual Offshore Technology Conference, 3-6 May, Houston, TX, USA.

Dawson, J.A, (1966), Offshore Safety-Drilling Operations. SPE 1551, Oct 2-5, 41st Annual Fall Meeting of AIME, Dallas, TX, USA.

Ellis, P.W, (1981), Blowout Prevention and Well Control. Editions Technip, France.

Gupta, S.K., (2006), Basin architecture and petroleum system of Krishna Godavari Basin, east coast of India. The Leading Edge 25, 830; doi:10.1190/1.2221360.

Jain C.K, (1995), A Case Study on Blowout at Pasarlapudi, KG Basin, Internal Report.

Kelly, M.J, (1993), Part 10-Blowout surface intervention methods: Descriptions of debris removal techniques; special services like junk shots, hot tapping and freezing; and proven methods of well capping [Online] Available: <http://www.jwco.com/technical-literature/p10.htm>

DGH, Krishna Godavari basin. [Online] Available: <http://www.dghindia.org/16.aspx> (July 7, 2010)

Madduri V.B.N.S, Mohan Reddy E, (2003), An Environmental Assessment of Oil and Gas Exploration, Environmental Economics Research Committee, Theme: Industrial Pollution and Policy, IPP-8, University of Hyderabad, Hyderabad, India.

Pantulu, C.C, Fire Spreads Panic on AP Coast. [Online] Available: http://www.dnaindia.com/india/report ONGC-fire-spreads-panic-on-ap-coast_1484 (Sep 9, 2005)

Rao, G.N, (2001), Sedimentation, Stratigraphy, and Petroleum Potential of Krishna-Godavari Basin, East Coast of India. AAPG Bulletin, v. 85 no. 9 p. 1623-1643.

Sarma, R.S, Fire at ONGC's well in KG basin; no casualties. [Online] Available: <http://www.thehindubusinessline.in/2005/09/09/stories/2005090902790200.htm> (Sep 9, 2005)

Satyanarayana K., (2005), Case Studies on Blowout Prevention, Petrotech Benchmarking of HSE in Oil and Gas Industry. 1-3 Feb, Goa, India.

Shrivastava, R, Martin, M, Raging Rig. India Environment Portal. [Online] Available: <http://www.indiaenvironmentportal.org.in/news/raging-rig> (January 30, 1995)

Wright, J.W, (1993), Part 11 Relief wells: Advancements in technology and application engineering make the relief well a more practical blowout control option. [Online] Available: <http://www.jwco.com/technical-literature/p11.htm>

Works, M.T, (1944), Blowouts-Causes and Prevention. June 13-14, SPE Spring Meeting of South Western District, California, USA.

Yerramilli, S.S, Yerramilli, R.C., (2007), Blowout and its Control. B.Tech Minor Report (Internal), University of Petroleum and Energy Studies, Dehradun, Uttarakhand.

Nomenclature

°C Degrees Centigrade

DGH Directorate General of Hydrocarbons

KG Krishna-Godavari

MD Measured Depth

ROP Rate of Penetration

3D Three Dimensional

\$ Currency symbol for USD



Figure 1. Location of Krishna Godavari basin in the East coast of India (Bastia 2006).

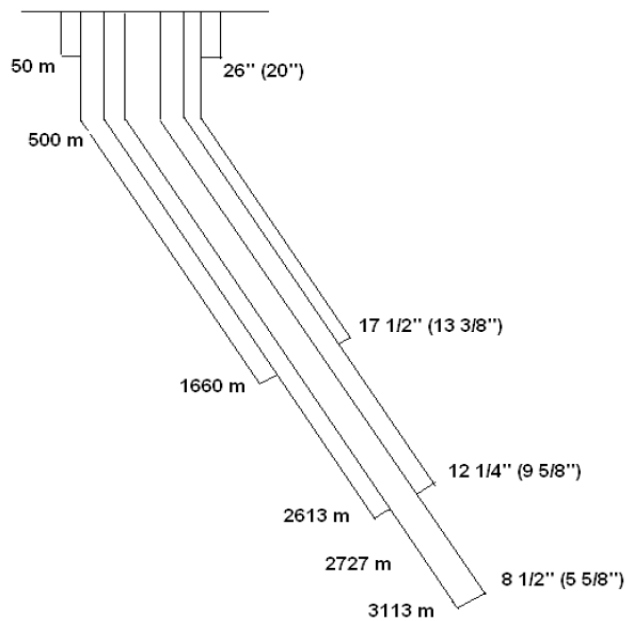

Figure 2. Schematic of well configuration (Jain 1995).



Figure 3. Real photograph showing the height of the flame and the spewing gas.

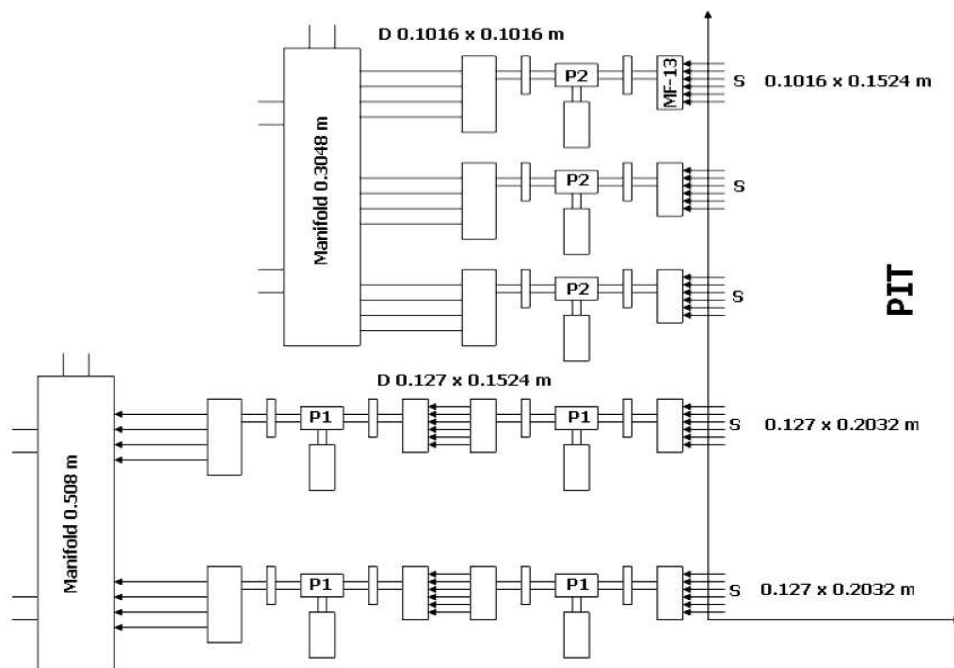

Figure 4. Arrangement of water pumps to create a water umbrella over the flame (Jain, 1995).



Figure 5. Athey Wagon clearing the debris at the well site.

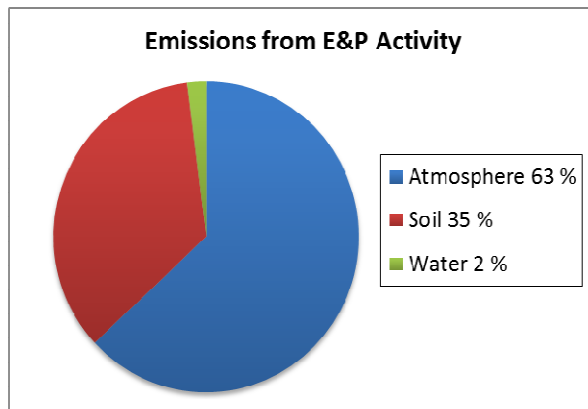

Figure 6. Relative contribution of emissions from E&P activity to Atmosphere, Soil and Water.

Casing	Depth (m)	Casing Size (inch)	Bit Size (inch)
Conductor Casing	50	20	26
Surface Casing	1660	13.375	17 ½
Intermediate Casing	2613	9.625	12 ¼
Production Casing	3113	5.625	8 ½

Table 1. Bit sizes used and casing programme of the well (Jain 1995).

Type of Pump	Discharge (m ³ /min)	Head (m)	Suction and Delivery Manifolds
Red Adair 2 sets in series	18.92706 each	129.54	0.127×0.2032 m suction, 0.127×0.1524 m delivery connected to 0.508 m manifold
Kirloskar 2 Nos.	15.14165 each	129.54	0.1016×0.1524 m suction and 0.1016×0.1016 m delivery connected to 1.8542 m manifold
Transfer pumps 2 Nos.	15.14165	30.48	N.A.

Table 2. Details of pumps used for creating water umbrella over the flame (Jain 1995).

This academic article was published by The International Institute for Science, Technology and Education (IISTE). The IISTE is a pioneer in the Open Access Publishing service based in the U.S. and Europe. The aim of the institute is Accelerating Global Knowledge Sharing.

More information about the publisher can be found in the IISTE's homepage:

<http://www.iiste.org>

The IISTE is currently hosting more than 30 peer-reviewed academic journals and collaborating with academic institutions around the world. **Prospective authors of IISTE journals can find the submission instruction on the following page:**

<http://www.iiste.org/Journals/>

The IISTE editorial team promises to review and publish all the qualified submissions in a fast manner. All the journals articles are available online to the readers all over the world without financial, legal, or technical barriers other than those inseparable from gaining access to the internet itself. Printed version of the journals is also available upon request of readers and authors.

IISTE Knowledge Sharing Partners

EBSCO, Index Copernicus, Ulrich's Periodicals Directory, JournalTOCS, PKP Open Archives Harvester, Bielefeld Academic Search Engine, Elektronische Zeitschriftenbibliothek EZB, Open J-Gate, OCLC WorldCat, Universe Digital Library, NewJour, Google Scholar

