

Construction And Testing Of Ultrasonic Bird Repeller

EZEONU Stella Ogochukwu^{1*}, AMAEFULE Desmond Okechukwu² and OKONKWO Godfrey Nnaegbo³

1. Department of Physics/Industrial Physics Nnamdi Azikiwe University, Awka
2. Department of Agricultural and Bioresources Engineering Nnamdi Azikiwe University, Awka
3. Department of Science Laboratory Technology Federal Polytechnic, Bida

*Email: ogooezeonu@yahoo.co.uk

Abstract

The threat posed by birds to economic crops in the farms or at storage facilities requires the deployment of an effective bird deterrent in such locations. Many attempts have been made to develop successful bird deterrent systems with only a few achieving desired results. The ultrasonic frequency range 15-25 kHz is known to be disturbing to birds and a device operating at that range was developed. The output of the integral oscillator was fed to 4 piezo transducers, placed 90° to each other to produce a dispersion of overlapping fans of sound for full 360° coverage. The power of the first device was 7.98W and the intensity of the sound pressure at 1m was calculated to be $6.35 \times 10^{-1} \text{W/m}^2$ at 118dB. A second device was constructed which had a power of 23.98W and intensity of the emitted sound at 1m, 1.91W/m^2 at 123dB. The devices were tested and the results obtained showed that the ultrasonic beam from the piezo speakers was able to drive birds away from designated areas. Further tests conducted with the unit showed a wider reach of the waves on a dull day than on a sunny day. About 5-6 of the second device is expected to cover one hectare of field. The device is solar powered, eliminating the cost of fuel, the inconvenience of regular attention and its protection from environmental perturbation. It is environmentally friendly.

Keywords: Pest birds, Bird repeller, Solar powered, Ultrasonic, Frequency range, Environmentally friendly.

1. Introduction

Birds exist in our natural environment. Though some of these birds are beneficial to man, a few species of them can be detrimental to human beings. Birds can be a nuisance when they cause damage and health problems. A survey of the New Zealand farmers by the nation's Plant Protection Society, revealed that large percentage of them had encountered crop damage from birds (Coleman & Spurr 2001). In Nigeria, farmers especially those located in the northern region encounter damage to their crop from bird pests. The magnitude of destruction caused by these bird pests can sometimes be really great. Catastrophic crop losses resulted in many African countries within nearly 2 decades (1955 to well into the 1970's) from the highly gregarious quelea birds' (*Quelea quelea*) sporadic attacks despite diverse control measures adopted then (Schmutterer 1978, Ward 1979). In Nigeria, this same pest destroyed about 45,000 hectares of rice farm under the Bakalori Irrigation scheme (located in Sokoto State Nigeria) in 2005 prompting a lot of money to be spent on procuring avicides for their control (Ezeonu 2009). Disease transmission (wikipedia.org/wiki/transmission_Site), fouling of the environment with birds dropping plus the attendant insect infestation and the damage of vehicles and glass structures from bird strikes, *inter alia*, are other nuisance factors of birds to man.

Several devices have been used to control the menace of birds both at the airports and farms but the use of electronic scarecrows is a relatively new invention. While seeking the protection of human concerns from avian menace, the researchers adopted an environmentally friendly-bird protection technique like ultrasonic so as to preserve the role of birds in global environmental balance. Some studies have been carried out to evaluate objectively the effect of ultrasonics on birds (Meylan 1978, Martins & Martins 1984, Kerns 1985). Apart from Meyhan's (1978) whose device operated below the ultrasonic frequency (16kHz), these studies have not demonstrated effectiveness in the use of ultrasonics in repelling birds (Woronecki 1988). Meylan (1978) reported that an ultrasonic device was used successfully in reducing damage to sunflower by greenfinches (*Carduelis Moris*) in Switzerland in 1977. Meylan (1978) reported that the damage during the one month the unit operated was low but increased considerably after the unit was removed. Meylan subsequently noted that the unit operated at only about 16,000 Hz (Woronecki, 1988). Thus, the sound waves that deterred the birds were considerably below ultrasonic frequency.

Nankinov D et al (2007) tested a commercial ultrasonic unit of Conrad Company aimed at scaring rodents against some species of birds. The investigation was carried out using a specially prepared feeding place at Bulgarian ornithological center which was visited by doves, starlings and sparrows. The device produced an output of 30 kHz.

Nankinov D et al (2007) reported that the ultrasonic sound produced by the device has no noticeable effect on the birds but observed that the number of birds visiting the feeding station reduced significantly after the 10th day. This development was related to the influence of the device as well as to the advancing period for nesting for the majority of the birds (Nankinov D et al, 2007).

Hamershock (1992) and Bomford and O'Brien (1990) in their reviews of published research in ultrasonic repeller reported that there was no evidence that ultrasonic devices had any effect on avian behavior, including dispersal

Ultrasonic sound, defined with man as reference, has frequencies above those heard by man (20Hz - 20 kHz). Most birds hear about the same range as human beings (Encarta 2003), some small birds however, do not hear low frequency sounds but can detect sound of high frequencies that human beings cannot. Generally birds have ultrasonic limit lower than that of man (Frings 1964).

The aim of the study is to fabricate a solar-powered ultrasonic device to scare birds away from designated areas.

2. Device Construction

The block diagram of the circuit device consists of the frequency scanner, the frequency generator, the power drive and the output transducer, see figure 1.

2.1 Frequency Scanner: The frequency scanner consists of an IC 555 timer and a decade counter, (figure 2). The frequency of the ultrasonic oscillator was continuously varied between 15-25kHz automatically. Five steps of variation were used. The 555 timer used as a low frequency square wave oscillator was biased to give an output frequency of 250Hz (such that the output of each division of the counter represented 50Hz). The output frequency of the timer (see figure 3) was used as a clock input of a decade counter. For each clock pulse output from the timer, the logic 1 output of the decade counter shifts from Q₀ to Q₄. Five preset variable resistors- VR1 – VR5 (each connected at Q₀ to Q₄ output pins) are set at different values. The VR6 was used to change the clock pulse rate.

2.2 The Frequency Generator: This consists of another 555 timer and a dual D flip flop, (see figure 4). The voltages from the five outputs of the decade counter are connected through D1-D5 and VR1- VR5 respectively to this 555 timer wired as an astable multivibrator operating at a high frequency. This timer oscillates in the ultrasonic frequencies generated by the five presets. The frequency outputs of this 555 timer is not symmetrical but is fed to a dual D flip flop which delivers symmetrical signals at its outputs.

2.3 The Power Drive: This consists of a push-pull type amplifier, (see figure 5). The amplifier was used to magnify the output signal from the dual D flip flop. Here complementary transistors (NPN and PNP) were used to obtain a full cycle output across a load using half cycles of operation from each transistor. A single input was applied to the base of both transistors.

The transistors, being of opposite types, conduct on opposite half cycles of the input. The NPN transistor was biased into conduction by the positive half cycle of the signal, with the resulting positive half cycle across the load. During the negative half cycle of the signal the PNP transistor was equally biased into conduction giving also a negative output. During a complete cycle of the input, a complete cycle of the output signal was developed across the load. The load was driven as the output of an emitter follower so that the load resistance is matched by the low output resistance of the driving source (Boylestad & Nashelsky 1996) and this buffers the signal. The output power of the amplifier is 7.98W.

2.4 The Output Transducers: The symmetrical outputs from the dual D flip flop are amplified in push-pull mode by transistors Q₁ - Q₄ to drive the four high frequency piezo tweeters. When the quartz plate of the transducer is subjected to an alternating electric field, the reverse piezoelectric effect causes it to expand and contract at the field frequency. If this field frequency is made to coincide with the natural elastic frequency of the crystal, the plate resonates. This physical displacement propagates sound waves.

The combination of the subsections' circuits constituted the complete circuit of the ultrasonic bird repeller, (see figure 6). In constructing the device, a printed circuit board was used. The printed circuit board was produced using the toner transfer method (Gootee 2003). The device was powered by a 12V solar panel. The picture of the repeller is shown in figure 7, with its solar photovoltaic panel power source.

The output power of the device was 7.98watts. The intensity (I) of the sound emitted by the device at a distance of 1m was calculated to be $6.35 \times 10^{-1} \text{W/m}^2$ using the inverse square law

$$(I = P / 4\pi r^2)$$

where P is the power and r is the distance covered.

The sound pressure level is given as

$$\text{SPL(dB)} = 10 \log (I/I_r)$$

Where I_r is the reference intensity and is equivalent to 10^{-12}W/m^2 . This gave a calculated sound pressure level of 118dB. Another ultrasonic repeller with a higher power was constructed. Its power was 23.98watts; three times the output power of the first one. The intensity of its emitted sound at 1m distance was also calculated to be 1.908w/m^2 , and the sound pressure level 123dB.

3. Testing and Results

The circuit constructed was tested. When the circuit was powered, an electric signal was generated and this signal generated was converted to ultrasound by the piezo transducer. Ultrasonic level detector (instrument) was used for detecting the signals propagated from these devices. Detection test for signals produced showed that the arrangement of the four piezo ceramic speakers placed at 90° to each other produced 360° sound dispersion coverage. The frequency of the emitted ultrasound varied continuously between 15 kHz and 25 kHz automatically. Observations of birds' reactions to the broadcasted waves were made. For experimental control, the birds' response in portions of the field where the broadcasted waves did not reach was observed. Simple average was employed in evaluating the signal reach from the raw data obtained.

3.1 Signal Attenuation Due To Atmospheric Effect: It was noted that the high frequency sound waves produced by the piezo speakers attenuated in intensity with increasing distance from the sound source at a specific rate as shown in figure 8. This was true for sunny, rainy and dull days. It can be observed in figure 8 that the ultrasound generated by the device traveled slightly farther in moist air (7.0m reach) than in dry air (less than 6m reach). This is primarily due to the lower concentration of Carbon (IV) Oxide (CO_2) in moist air due to its solubility in water and of dust particulate matter in moist air. These and the higher concentration of water vapour means a lower air density. Conversely, on sunny days, the dry air is of comparatively higher density and contains entrained dust particles; such air will therefore vibrate less readily. Sound travels more slowly through such a medium. This explains why the attenuation was less on a rainy day than on a sunny day. This phenomenon is an advantage since the device will be very useful to farmers especially during the rainy season; when fruits of rain-fed cereal crops develop and granivorous birds' nuisance pervades

3.2 Effect of Gadget Elevation on the Signal Reach: The performance of the two ultrasonic devices were compared when placed on three different heights (viz: 0.79m depicted as 1, 1.38m as 2 and 1.86m as 3) on both sunny and dull days. On the average, the first device covered an area of 45.02 square meters while the second device covered an area of 232.26 square meters when placed on an elevation of 0.79m, while when placed on an elevation of 1.86m, they covered an area of 175.83 and 429.53 square meters respectively. Thus about 5-6 pieces of the second device will effectively cover a hectare. The effect of gadget's power and elevation on the reach of the generated signals is shown in figure 9.

From figure 9, the following can be observed:-

- (i) When the power of the device increases (from 7.98W to 23.98W), the distance the sound travelled also increases (from 5.8m to 12.5m on a sunny day and from 6.5m to 17.5m on a dull day for a device elevation of 0.79m). This is hardly surprising.
- (ii) As the gadget elevation increases (from 0.79m to 1.38m, and 1.86m), the reach of the sound increases: (from 5.8m to 7.6m, and 12m for device 1 and from 12.5m to 16.5m, and 18.6 for device 2 respectively on a sunny day). Similar trend was obtained for a dull day test. This should most likely be as a result of less obstacles interference with the transmission.
- (iii) The sound travels farther on a dull day than on a sunny day; (from a reach of 5.8m to 6.5m, 7.6m to 12.8m and 12m to 14.7m for a sunny and dull day respectively with device 1 placed at corresponding heights of 0.79m, 1.38m and 1.86m). A similar result was obtained for device 2 whose reach increased from 12.5m to 17.7m, 16.5m to 19m and 18.6m to 22.9m for given weather conditions and heights as in device 1, in the same order. The reason is as was explained earlier on.

3.3 Field Testing

Observations showed that the birds' activity would be greatest early in the morning and gradually decline as the day progresses. This corroborated with the findings of Schmutterer (1978) that quelea birds feed early in the mornings and late afternoon, but rest and drink in-between. Consequently the field testing was conducted between 7am and 12noon. The whole exercise lasted for 7 days. The field testing of the device was carried out in the outskirts of Birnin Kebbi, Kebbi State in northern Nigeria. The test was carried out in fields planted with cereal crops at fruiting stage with adjoining savannah bush. The targeted bird species were black birds, weaver birds (a *Ploceida*) and Quelea birds. The weaver birds and quelea birds' flocks were on the average of 80 and over 400 in order but the black birds do not move in flock.

3.4 Repellant Impact of the Device on the Birds:

i) During the tests both the blackbirds and weaverbirds responded to the stimulus occasioned by the generated waves. The birds that responded usually move some meters away from their perch but did not leave the area entirely. This observation may be due to the fact that when ultrasound is broadcast over wide open spaces, the sound waves lose their intensity rapidly with distance and dissipate (www.bugspray.com).

ii) Quelea birds on the other hand were a species that it was difficult to elicit good noticeable response to the stimulus from the device. They did not respond like the other birds and seemed to be unaffected much by the ultrasonic waves. The reason needs understanding but was thought to be the enormity of their flock size.

iii) During the experiment, it was also observed that the resting and loafing birds are easily dispersed than the feeding birds since it is always difficult to break the habit once they are feeding as reported by (Bishop et al 2003).

A break in the signals broadcast was ensured when the birds have given their maximum response to the stimulus so as to avoid the birds' habituation to the device signal.

4. CONCLUSION

The use of ultrasonic waves; which human ears do not detect, but are perceived by small birds is a novel technology that can effectively repel such birds from designated places. Ultrasonic waves was successfully generated, with automatically varied frequency (between 15kHz and 25kHz), amplified and broadcast at high enough sound pressure level from a locally fabricated solar powered electronic device. The 7.98W device produced an ultrasound of 118dB, on the average will cover a distance of 45.02m² while the 23.98W with an ultrasound of 123dB will cover a distance of 232.26m² when placed on the elevation of 0.78m but when placed on the elevation of 1.86m, their average area coverage will be 175.83m² and 429.53m² respectively. The ultrasonic waves created a hostile environment for the pest birds and had a repulsive influence on them, though they have a small radius of action but eventually drove the birds away from the designated locations. Response to the ultrasonic wave stimulus broadcasted from the environmentally friendly gadget was visibly demonstrated by targeted weaver birds and black birds but not quelea birds. The waves travelled farther with increasing power of the gadget and for wet days than for dry days. This is advantageous as rain-fed cereal crops fruit during the rainy season and will need the deployment of the gadget more at such a period. About 5-6 pieces of the 23.98W device will be needed to cover a hectare sized field.

References

1. Bishop J, McKay H, Parrot D & Allan J (2003). Review of International Research Literature Regarding the Effectiveness of Auditory Bird Scaring Techniques. www.defra.gov.uk/environment/noise/birdscaring.pdf - Retrieved on 25/03/2009.
2. Bomford, M and O'Brien, R H (1990). "Sonic Deterrents in Animal damage Control: A Review of Device Tests and Effectiveness". *Wild. Soc. Bull* 18:411-422
3. Boylestad, R.L and Nashelsky, L (1996) *Electronics and Circuit theory*, (6th ed), Prentice Hall, New Jersey, USA. 72.
4. Coleman, J and Spurr, E (2001) Farmers Perceptions of Bird damage and Control in Arable Crops. The New Zealand Plant Protection Society Incorporated.

5. Encarta Encyclopedia 1993-2003 Microsoft Corporation .
6. Ezeonu S.O (2009). The solar powered ultrasonic and sonic bird repellents. An unpublished PhD thesis, Dept of Physics/Industrial Physics, Nnamdi Azikiwe University, Awka , Nigeria
7. Frings, H. (1964). Sound in vertebrate pest control. *Proc. Vert. Conf.* 2:50-56.
8. Gootee, T. (2003). <http://www.fullnet.com/u/tomg/gooteepc.htm>. - Retrieved 6th July, 2005
9. Hamershock, D M (1992). "Ultrasonic as a Method of Bird Control" *Flight Dynamics Directorate*, Wright-Patterson AFB, OH, 42.
10. Kerns, J. D. (1985). "Evaluation of the effectiveness of the 'Ultrason ET' ultrasonic device as a means of cliff swallow control" In: Woronecki, P.P. Effects of ultrasonic, visual, and sonic devices on pigeon numbers in a vacant building. *Proc. Vert. Pest Conf.* Monterey, California 13:266-272
11. Martin, L. R. and P. C. Martin. (1984). "Research Indicates Propane Cannons can Move Birds" In: Woronecki, P.P. Effects of ultrasonic, visual, and sonic devices on pigeon numbers in a vacant building. *Proc. Vert. Pest Conf.* Monterey, California 13:266-272.
12. Meylan, A (1978). Granivorous birds in sunflower crops. *Proceedings of Vertebrate Pests Conference* 8:73-77, Sacramento, California
13. Nankinov, D, Ivanon N, Nikolov B, Dalakchieva S, Gluhchev G and Trifonov D (2007). "Electro-Acoustic Influence on Birds" *Bularian Academy of Sciences (Cybernetics and Information Technologies)* 7:106-111
14. Schmutterer, H. (1978). Birds. In: Kranz, J.; Schmutterer, H. and Koch, W. (Editors) *Diseases, Pests and Weeds In Tropical Crops*. John Willey and Sons New York :532-536
15. Ward, P. (1979). Rational strategies for the control of queleas and other migrant bird pests in Africa. Strategy and Tactics of Control of Migrant Pests. A Royal Society Discussion held on 29 and 30 June 1977. The Royal Society London :289-300
16. Woronecki, P.P. (1988). Effects of ultrasonic, visual, and sonic devices on pigeon numbers in a vacant building. *Proc. Vert. Pest Conf.* Monterey, California 13:266-272.
17. Wikipedia (indated). Transmission and infection of H5N1. Wikipedia The Free Encyclopedia [en.wikipedia.org/wiki/transmission_](http://en.wikipedia.org/wiki/transmission) Site visited on 9/2/2012
18. www.bugspray.com – Retrieved on 3/11/2006

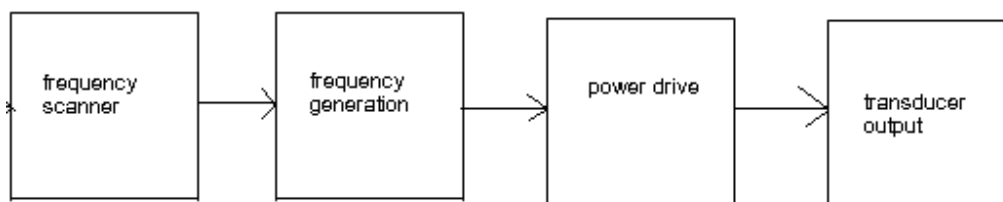

Fig 1: The block diagram of the ultrasonic bird repeller

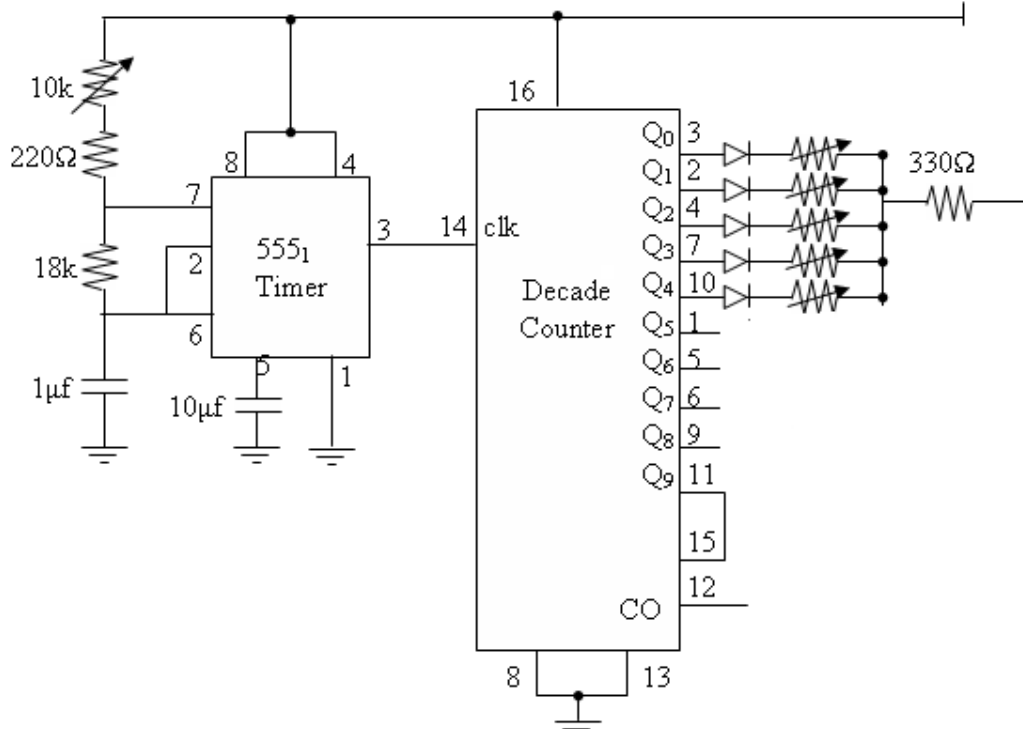

Fig 2: The circuit diagram of the frequency scanner

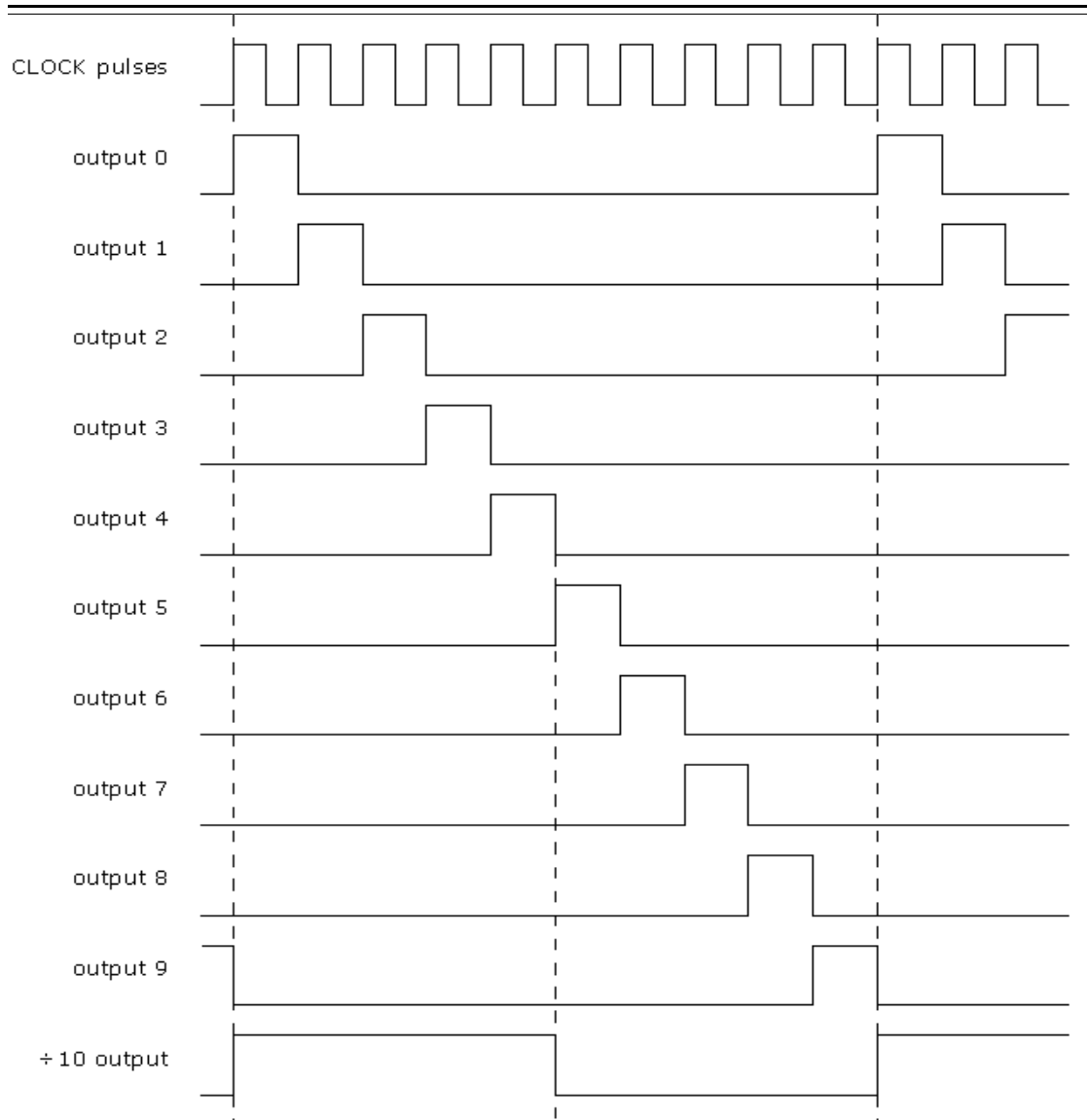

Fig 3: The ten separate outputs of the decade counter

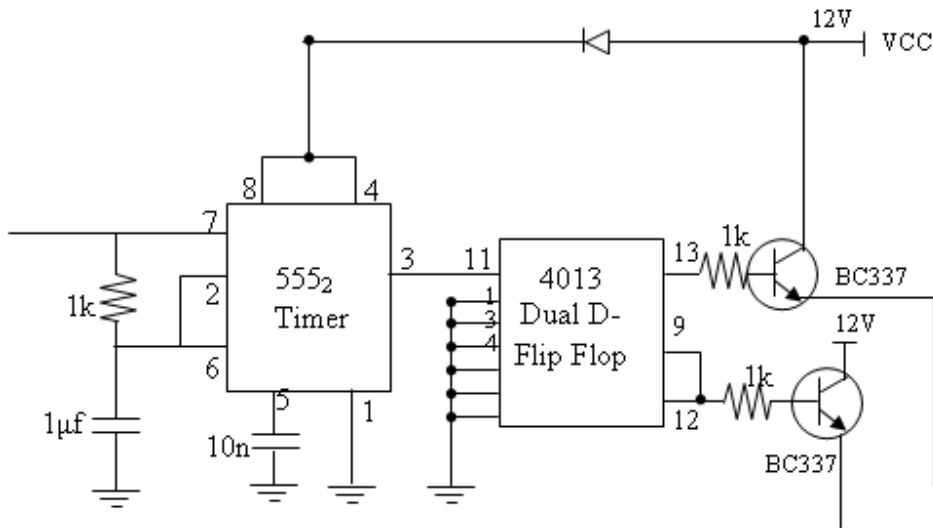

Fig 4: The circuit diagram of the frequency generator

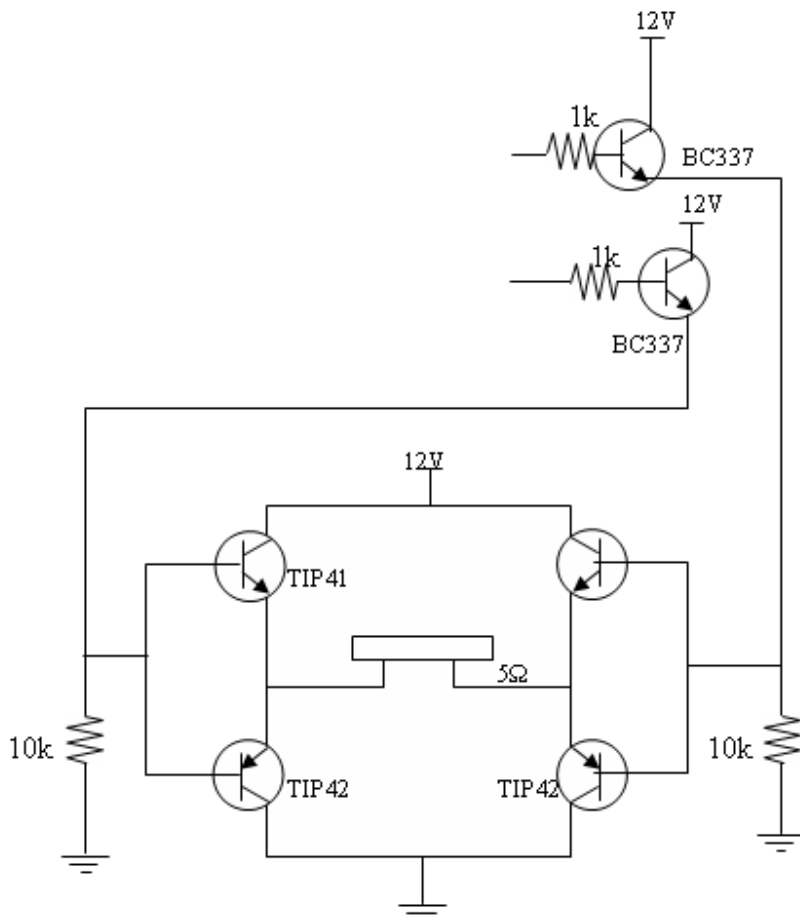

Fig 5: The circuit diagram of a push-pull amplifier

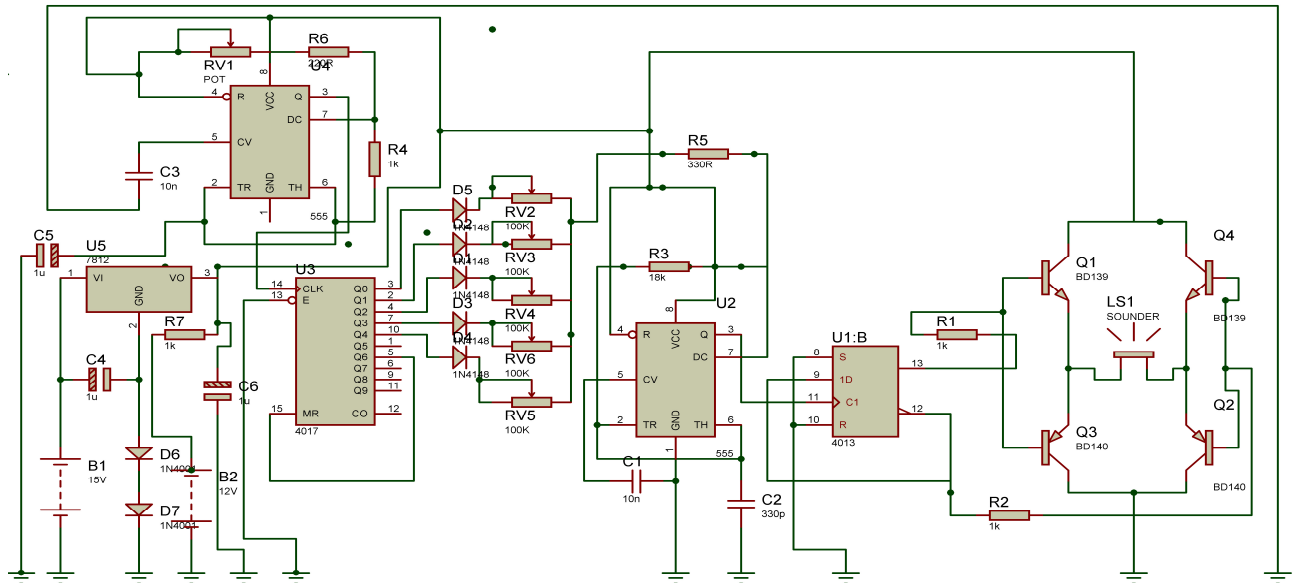

Fig 6: A complete circuit diagram of the ultrasonic bird repeller



Fig 7: The picture of the ultrasonic bird repeller

SIGNAL ATTENUATION DUE TO ATMOSPHERIC EFFECT

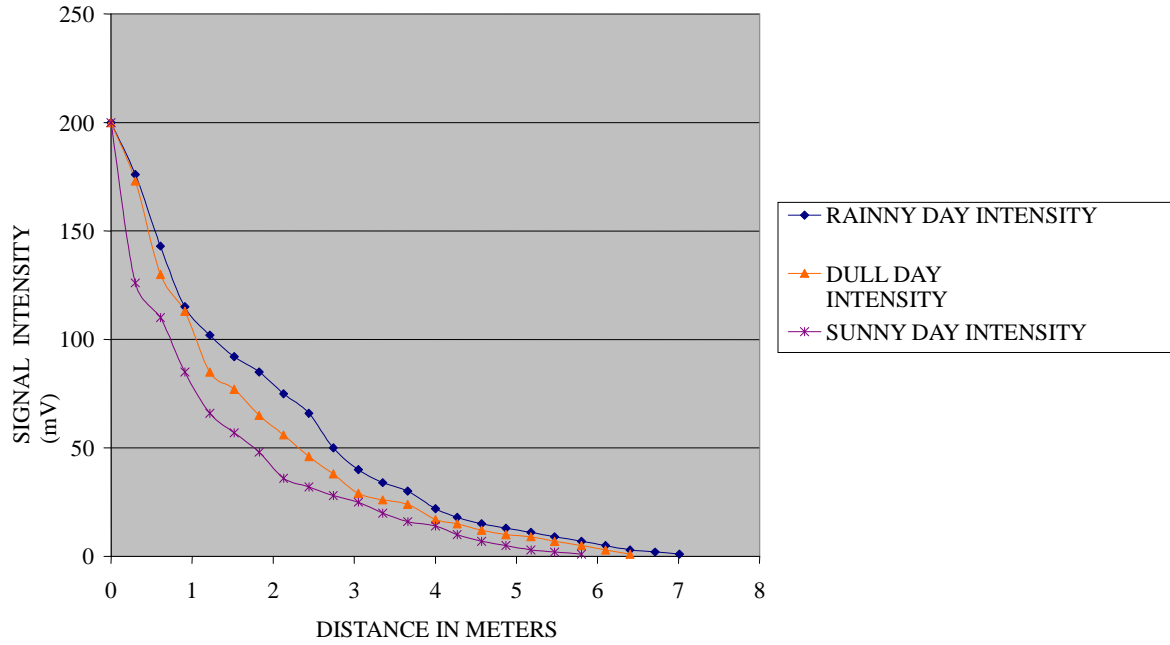

Fig 8: Attenuation of ultrasound waves with distances and weather condition

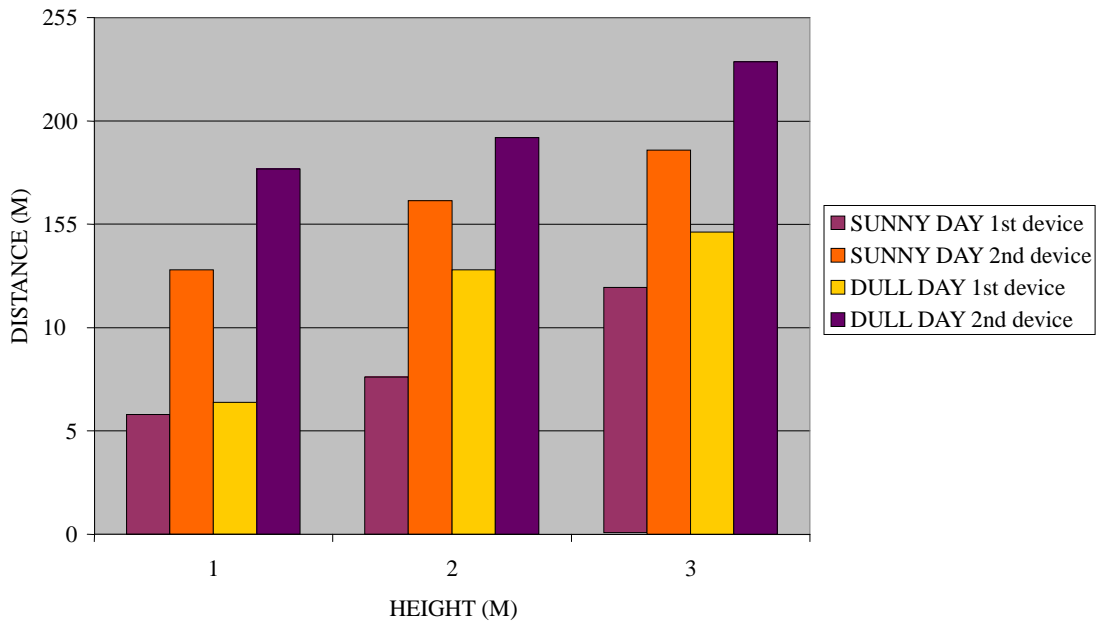

Fig 9: Bar chart of the reach of the two devices from 3 different heights on sunny and dull days.