

# A new Environmental, Pollution and Soil Monitoring (EPSm) System

<sup>1</sup>Lanre Daniyan, <sup>2</sup>Ezechi Nwachukwu, <sup>3</sup>Onyenwaoma Nnaemeka, <sup>4</sup>Chapi Jonah, <sup>5</sup>Kevin Eze, <sup>6</sup>Justus Chukwunoye, <sup>7</sup>Joy Wali, <sup>8</sup>Nwagbara Donatus, <sup>9</sup>Adejoh Joshua, <sup>10</sup>Obi Nnamdi, <sup>11</sup>Okeke Nonso, <sup>12</sup>Ezinwa Vincent, <sup>13</sup>Umeh Constance, <sup>14</sup>Eze Ogochukwu

<sup>1-14</sup>Instrumentation Division, NASRDA Centre for Basic Space Science, Nsukka.

## Abstract

This paper presents the design and development of Environmental, Pollution and Soil Monitoring (EPSm) Station using the four – stage Architecture Design Modelling Development (ADMD) process. The Solar powered EPSm station uses indigenous technology to deliver about Thirteen (13) real time variables, on – board modelling, user-defined functions, remote data transmission to clients' mobile phones and dedicated website while offering cost effectiveness among others. Data validation and calibration were done using known standard devices. The system was design to lodge data in Comma Separated Value (CSV) format in micro SD card with site coordinates and owner's information stamped on the data table. The system is design to be highly modular in order to provide the ease of troubleshooting and maintenance if required. The overall features, capabilities and performance of the EPSm station positions it to be a one-stop facility for a wide scenario of environmental variability measurements and succour to research community.

**Keywords:** Automation, Calibration, Modularity, Simulation, Validation.

## 1. Introduction

CBSS is an activity Centre of National Space Research and Development Agency (NASRDA) charged with the mandate to carry out frontline research in Space Science and Astronomy in Nigeria. The EPSm station is one of the indigenous projects that emanate from the Instrumentation Division of the Centre. It is one of the numerous ways the Division supports the realization of the Centre's mandate through the design and fabrication of frontline scientific research equipment.

The EPSm system is a smart outdoor system that is designed to comprehensively carry out real time measurement of environmental and soil monitoring. Thirteen real time variables being handled by the system include Ambient Temperature, Relative Humidity, Solar Radiation, Atmospheric Pressure, Soil Temperature, Soil Moisture, Soil PH, Precipitation, Aerosol, UV Radiation, site GPS coordinates and Gas Pollution. The system could handle any of Gases such as CO, CO<sub>2</sub>, NO, NO<sub>2</sub>, LPG or NH<sub>3</sub>. Data are stored in an on – board Secure Digital (SD) card for subsequent processing.

The on – board micro server on the control board provides automation and advance communications on – site. Real time variables, thresholds and alerts are sent to registered users mobile devices with the aid of the micro server. Also, the micro server push data directly to a dedicated website for on – line access by authorized users. On – site real time modelling is performed with the aid of a push button provided on the control board. The result is display on the 7 inches TFT screen installed in the enclosure box.

The TFT screen provides visual evaluation of the real – time data, model results or visual inspection of the operational status of the EPSm System with the aid of a push button.

## 2. Architecture

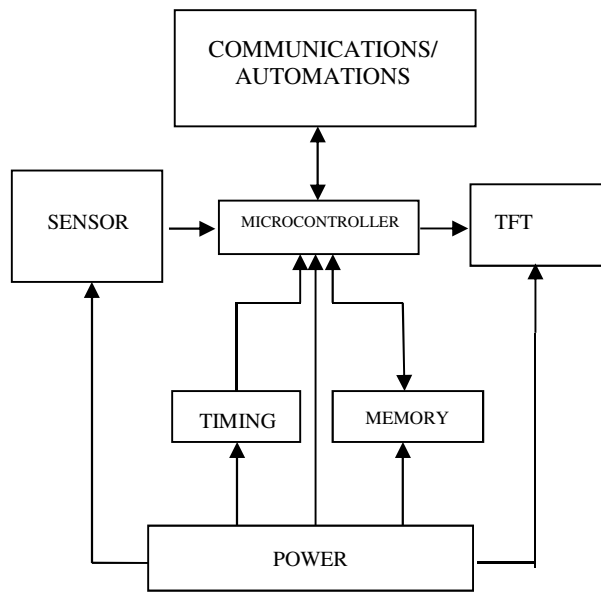

Figure 1. Simplified Architecture of the EPSm System

The architecture features seven principal subsystems which are the Power Management, Timing, Memory, Sensor Array, Microcontroller, Display and Communications subsystems. As shown in Fig 1 below, the Power Management handles the varied power requirement by different sensors, modules and subsystems. It equally helps to bring all sensors and modules to the same logic state. The Timing system provides timing series for the data and time control for program execution. The memory is made up of a 32Gbyte Secure Digital card where the data table is stored and updated. The group of sensors relaying information to the controller forms the Sensor Array. The Microcontroller is the central processing system of the station. It coordinates and handles all activities such as computational, control and data processing. The display is a 7-inch TFT screen that provides visual presentation of the real – time operations of the system. The communications subsystem performs automations and on – board web push.

## 3. Simplified Proteus Model

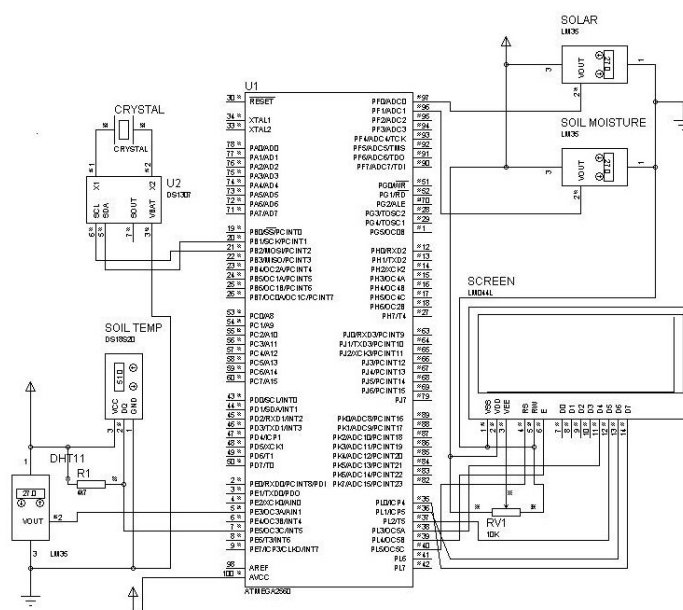

Figure 2. Sectional Proteus Sample Model of the EPSm Design

Figure 2 above shows the model design of the EPSm system for simulation using Proteus for a few of the system sensors.

#### 4. System Design

The design is based on the versatile Atmel 2560 microcontroller chip as shown in Fig 2 above. The sensor array comprises sensor for Ambient Temperature, Relative Humidity, Solar radiation, Atmospheric Pressure, Soil Moisture, Soil Temperature, Soil PH, Precipitation, Global Positioning System (GPS) and Gases Pollution. This group of sensors with digital and analog outputs, and different communication protocols are interfaced to the Microcontroller and programmed accordingly. The control board is made using Veroboard.

The power system is designed using 10Watt Monocrystalline PV module, a 10A charge controller and 12V/4A backup battery. With the aid of two voltage regulator (LM2596 and LM6009) modules, the needed 3.7Volts and 5Volts are supplied to their respective rails on the control board.

The data time series and control is provided by the aid of a simple RTC DS1307 chip equipped with a 32.768 KHz crystal oscillator and a backup 3Volt coin cell.

Automations and data web push are implemented with the aid of a SIM800L GSM/GPRS module on the control board. This module is design to SMS certain alerts and thresholds to pre – programmed user mobile phones and equally upload the data to a dedicated website.

The EPSm system is smart enough to know its location of deployment and also stamp this on the Data Table using the GPS module. Location information is essential in data processing, hence, the GPS system is programmed to stamp location coordinates such as Latitude, Longitude and Altitude on the Data Table.

Two push buttons are provided on the control board. The first is to call - up the TFT screen which is usually left in hibernation to save power. The second is used to perform on – board modelling.



Figure 3. The Enclosure Box

The control board is made to interface with all on – board devices via pre-configured modular sockets. These sockets which are assigned to specific device modules receive the peripherals on – board thus making the EPSm system highly modular. The essence of this modularity is to provide ease of subsystem isolation in the event of troubleshooting thereby making maintenance a lot easy.

A weather and humid proof Enclosure box (Figure 3 above) houses the control board, power, GPS and communication systems and the BMP180 sensor.

## 5. Data Table and Format

Data is stored in a 32Gbyte micro Secure Digital (SD) card located on the control board in Comma Separated Value (CSV) format. CSV files are easily transported into Spreadsheet applications for further processing. The top of the Data Table carries short information about the source (Instrumentation Division, NASRDA Centre for Basic Space Science, Nsukka) and the GPS location coordinates of the site. The main part of the data table shows the variable headings and the logged data.

S/N	Date	Time	Solar Irr. (w)	Amb. Temp.	RH (%)	Soil Temp (d)	Soil pH	Soil Moist (%)	Atm. Press. (r)	LPG Pollu. (u)	Aerosol (ppr)	L/V Rad. (w)	Precip. (mm)
1	29/06/16	8:17	44	25.2	75.8	25	N/A	0	964.766	0	N/A	N/A	N/A
2	29/06/16	8:21	47	25.3	76.6	25	N/A	0	964.8	0	N/A	N/A	N/A
3	29/06/16	8:25	45	25.4	78	25.05	N/A	0	964.986	0	N/A	N/A	N/A
4	29/06/16	8:29	44	25.5	78	25	N/A	0	965.084	0	N/A	N/A	N/A
5	29/06/16	8:33	44	25.6	78	25.25	N/A	0	965.144	0	N/A	N/A	N/A
6	29/06/16	8:38	41	25.74	78	25.25	N/A	0	965.252	0	N/A	N/A	N/A
7	29/06/16	8:42	37	25.9	78	25.25	N/A	0	965.278	0	N/A	N/A	N/A
8	29/06/16	8:46	36	25.96	78.4	25.25	N/A	0	965.314	0	N/A	N/A	N/A

Figure 4. Data Table Format in Spreadsheet

## 6. Data Visualization

The CSV data file is usually transported into Spreadsheet for research purposes. In the event that there is a need to carry out visual evaluation of the real – time data, model results or visual inspection of the operational status of the EPsm system, the 7-inch TFT screen is called – up. With the aid of a push button, information such as real time data, logged errors (in case a sensor fails), Memory utilization and also programmed model results are displayed on the TFT screen in a tabular format.

## 7. Data Validation and Calibration

To ensure the quality of data being generated is suitable for frontline research, data validation is done using the Campbell Scientific Automatic Meteorological Station at Centre for Basic Space Science, Nsukka, Enugu State, Nigeria. Necessary calibrations were done using standard equipment and procedures at the Engineering Workshop of the Centre.

## 8. Installation

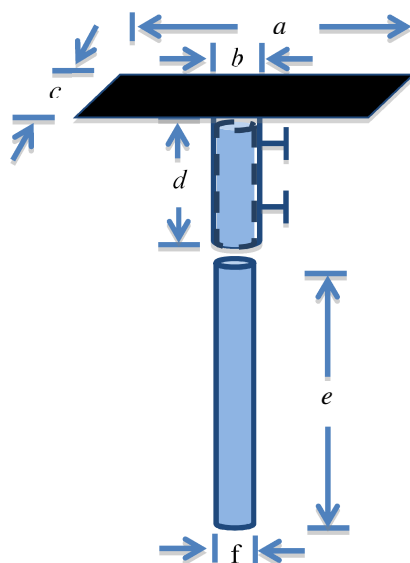

Figure5. EPsm Mounting Brackets

Where:

$$a = 27\text{cm}; b = 8.5\text{cm}, c = 15\text{cm}; d = 22\text{cm},$$

The EPSm system is design to have a simplified installation. The Enclosure box sits atop a steel metal bracket (dimension: a.c) for installation. The metal bracket wears smoothly via (d) with diameter (b) and locks firmly (using the two bolts provided on the base bracket) on a simple pole with diameter (f). The height (e) is determined by the user and the intended science to be done by the user. No mast is required. It takes about twenty minutes to install the system.

## 9. Cost Benefit

The current dollar exchange rate in Nigeria is alarming. This has made foreign made research instruments to be expensive and difficult to acquire. The EPSm system is indigenous and its installation is simplified when compared to Campbell Scientific meteorological System that requires about a three – meter tall mast for its installation. The technology is indigenous, its peripheral parts are sourced locally, its capacity and capability is exhaustive and the quality of data generated is good for any frontline research. All these have made EPSm system much cheaper and affordable compared to foreign made instruments.

## 10. Significance of the work

The African research community has been plagued with a host of problems such as inadequate facilities to support research, expensive nature of foreign instruments, instruments not built to users' specification, instruments not customized, lack of expertise to fix equipment failures, some instruments do not take account of the peculiarity of local environment in the design and production, knowledge deficit on instruments that support our research among others. All these are what the EPSm station is addressing by making indigenous equipment available and affordable for frontline research. While it is easily customized, users intended science needs and goals are also taken into account in the course of design. Because it is indigenous, this facility is easily maintained in the rare event of failure or malfunction and users' awareness of its diversities and capabilities is very profound. EPSm system has really provided succour to the Nigerian research community especially in the area of environmental characterization.

## 11. Conclusion

The comprehensive coverage of EPSm system positions it to be a one – stop facility for a wide scenario of environmental and soil monitoring. The station was calibrated and its dataset validated with this counterpart station, the NECOP station, hence it is highly recommended for frontline research. Its indigenous technology makes it to be cost effective compared to foreign made instruments while offering great capabilities. Its modularity and simplified architecture makes it exceptionally durable and reliable. Its advance features such as on – board modelling, remote wireless communications and visual real time presentation of operational information are highly innovative.

## References

- [1] Atmel, "Atmel ATmega640V-1280V-1281V-2560V-2561V, 8-bit Atmel Microcontroller with 16/32/64KB In-System Programmable Flash Datasheet".
- [2] Barringer and Associates Inc, "Electronic Reliability Design Handbook" U.S Department of Defence, October 1988.
- [3] Bosch, "BMP180 Digital pressure sensor" Revision 2.5, April, 2013.
- [4] Dallas Semiconductor, "DS18B20 Programmable Resolution 1-Wire Digital Thermometer" Datasheet, April, 2000.
- [5] Hanwei, "MQ series Semiconductor Gas Sensor" Datasheet.
- [6] Hongshen Ma, "Fundamentals of Electronic Circuit Design" Hongshen Ma 2005.
- [7] Krishna B. Misra, "Engineering Design: A Systems Approach" Springer, Handbook of Performability Engineering, 2008.
- [8] LOCOSYS Technology Inc, "Datasheet of GPS smart an Antenna module, LS20030~3". 2006.
- [9] Neil Storey, "Electronics A Systems Approach" Fourth Edition, Pearson Education Limited, 2009.
- [10] SIMCom, "SIM800L Hardware Design V1.00" August, 2013.