

# STATCOM Controller (Design and Assessment) for Transmission and Distribution System Problems

Muhammad Salman<sup>1</sup> Sohail Qureshi<sup>1</sup> Liaqat Ali<sup>2</sup> Sakhi Rehman<sup>2</sup> Nasrullah Khan<sup>1</sup>

1.Department of Electrical Engineering, COMSATS Institute of Information Technology, Islamabad, Pakistan

2.Department of Electrical Engineering, University of Science and Technology Bannu, Pakistan

## Abstract

Due to immense increase in needs of human being, the power generation system encounters a deficiency of key energy sources as a result the demand is increasing day by day without an increase in alternative generation resources and transmission line capability. The constantly increase of electrical power demands and loads, especially non-linear loads making the power system network become more complicate to operate and the system becomes unstable with large power flows without proper control and operation. The advancement in power system with time have brings new challenges and sometimes it is difficult to operate system in stable condition due to complex system network. One of the invention of power electronics is FACTS technology. FACTS (Flexible Alternating Current Transmission Systems) devices are based on power electronics and other dynamic controllers that provide control of one or more AC transmission system parameters to upgrade the controllability and to increase power transfer capability. One way to improve the power system control is by applying FACTS controllers such as D-STATCOM (Distribution Static Synchronous Compensator) which can be introduced to the power system to regulate terminal voltage and to improve power factor of system. A comprehensive D-STATCOM controller is to be established which when will be introduced in the power system will eliminate the voltage fluctuations and improve power stability. A test power system is being designed in MATLAB Sim Power System with non-linear load and wind energy source as renewable source and then the systems is analyzed with and without the D-STATCOM controller and both the result are being compared to check the performance of the designed D-STATCOM Controller.

**Keywords:** Unified Power Flow Controller (UPFC), Distribution Static Compensator (D-STATCOM), Static Synchronous Series Compensator (SSSC)

## 1. INTRODUCTION

Due to immense increase in needs of human being, the power generation system encounters a deficiency of key energy sources as a result the demand is increasing day by day without an increase in alternative generation resources and transmission line capability. All these reasons may have stressed the power system to operate beyond the capability it is built to be handled originally [1]. Voltage variations, Active and Reactive power stability, and power factor improvements are some of the key complications being faced by electric power utilities across the world. If not taken into account these issues can be a reason for power losses in lines, mal-function of critical loads, damage to customer equipment and possibly power system instability. Distribution Static Synchronous Compensator (D-STATCOM) is a speedily acting high power electronic dynamic reactive power compensator which is progressively being employed globally for the above purposes.

The importance of the implementation of FACTS devices to the power system will make the energy more and more efficient. With the increase of the FACTS systems implementing to the power system, the stability of the power system and also the power quality is becoming a major area of concern [2].

Renewable energy sources as wind and solar power are one of the most favorable distributed energy sources. Although there are some advantages of distributed energy sources which comprises of voltage maintenance, decrease in both the distribution and also transmission damages and enhanced consistency, complications of the power quality are also of worry.

Flexible AC Transmission system was proposed in 1995, which was then called as FACTS technology [3]. The main idea on which FACTS devices have been proposed to the world is to install the power electronics devices at the high-voltage transmission and distribution sides of the power grid in order to make the overall system controlled electronically. The advancement made in high power electronic semiconductor devices and control technologies have achieved the invention of FACTS devices [4]. The power compensation provided by FACTS devices could preserve the voltage of the whole power system due to which power flow can be easily controlled. Commonly, FACTS devices can be characterized into two (2) generations;

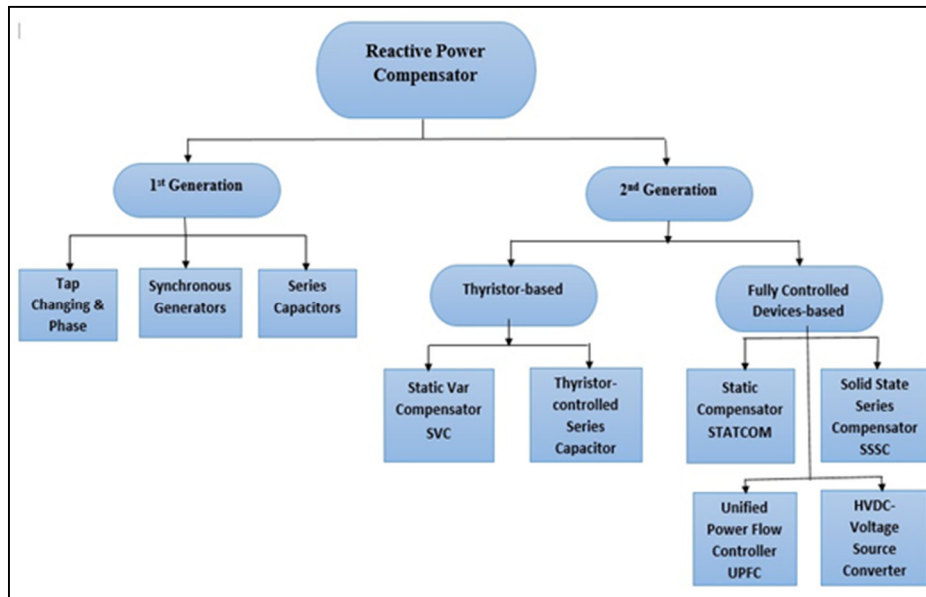

Figure 1.1: The categories of FACTS devices [6]

1<sup>st</sup> Generation of FACTS devices: Fixed capacitance and dynamic devices are 1<sup>st</sup> generation of the FACTS technology. These 1<sup>st</sup> generations of FACTS devices comprises of tap changing and phase changing transformers, series capacitors and synchronous generators. These are all dynamics devices excluding the series capacitors which are also called capacitor bank and are typically operated at the generation side of the power system but their cost is very high due to their extremely large size and maintenance. The big drawback of these devices is fixed series capacitors, since such devices are made up of several fixed-capacitance capacitors so these devices are very difficult to be controlled to give the exact not-fixed input capacitance to the grid.

Second Generation FACTS devices: Static state compensator is the second generation of FACTS technology. It can be divided into two categories: thyristor-based technology and fully-controlled compensator based technology. The thyristor controlled device is half controlled device because once the device is on then it cannot be switched off manually until the main power is cut-off [7].

Static Var Compensator (SVC) and Thyristor-Controlled Series Capacitor (TCSC) devices belong to this category [7]. While the fully controlled devices consist of Gate Turn-Off (GTO) thyristor i.e these device can be manually switched on and off when needed. The Static Compensator (STATCOM), Solid Static Series Compensator (SSSC) and Unified Power Flow Controller (UPFC) belong to fully-controlled devices. Different FACTS devices have different roles in improving the stability of power system during disturbances. Some of their roles are discussed in the following table;

Table 1.1: Various roles of different FACTS devices [5].

Type	Operation Problem	Corrective Action	FACTS Controllers
Voltage Limits	Low voltage at heavy load	Supply reactive power	STATCOM, SVC
	High Voltage at low load	Absorb reactive power	STATCOM, SVC, TCR
Thermal Limits	Transmission circuit overloaded	Reduce overload	TCSC, SSSC, UPFC
	Tripping of parallel circuits	Limit circuit loading	TCSC, SSSC, UPFC
Loop flows	Parallel line load sharing	Adjust series reactance	SSSC, UPFC, TCSC
	Power flow direction reversal	Adjust phase angle	SSSC, UPFC
	Post-fault power flow sharing	Rearrange network	TCSC, SSSC, UPFC

### 1.2 Problem Statement

Rapid increase in loads particularly non-linear loads and also in power demand, have stressed the power system to operate out of its capability for which it is built, makes the power system network more complicate to operate. This makes the system uncertain due to large power flows without enough control. This makes the system insecure due to voltage variations, Power factor instability. If these complications are not taken into account these issues can be a reason for power losses in lines, mal-function of critical loads, damage to customer equipment and possibly power system instability. For such purpose FACTS devices are introduced in power system to improve the voltage fluctuation, power factor's improvement and also removal of harmonic distortion [3].

For the purpose of power system stability a comprehensive D-STATCOM controller in synchronous rotating reference frame is introduced which counters all the problems of power system i.e. Voltage variations, Active and reactive power stability and Power factor improvement.

### 1.3 Research Hypothesis:

Voltage variations, Active and Reactive power stability, Total harmonic distortion (THD) and Power factor improvements are some of the key complications for power system which should be handled in order to achieve power system stability. Number of advantages could be gained if one can successfully address the above problems and efficiency of power system can be considerably increased by addressing voltage fluctuations, power factor improvement and active and reactive power problems in a power system. Furthermore, enhanced power factor will affect the efficiency as it increases the efficiency of the system or equipment and assist the system or equipment to last for extended time which on mean time also reduces the cos of electricity significantly. So FACTS devices should be researched to make our system more securable [2].

### 1.4 Research Objectives:

The scope of this research is to evaluate the enhancement capability of D-STATCOM for Voltage variations; Active and Reactive power stability and Power factor improvements by introducing it in a power system.

The Research objectives are as follow:

- i. Implementation of a power system with wind energy source.
- ii. Implementation and modelling of a comprehensive D-STATCOM controller.
- iii. To observe the performance of proposed system without D-STATCOM.
- iv. To study the voltage variation, active and reactive power and power factor of the proposed system without D-STATCOM.
- v. To observe the performance of proposed system with D-STATCOM.
- vi. To study the voltage variation, active and reactive power and power factor of the proposed system with D-STATCOM.
- vii. Comparison of the different parameters of the power system with and without D-STATCOM.

### 1.5 Research Methodology:

A power system with non-linear loads and wind energy source as renewable energy source is chosen as the proposed system which has to be tested for this research. To achieve the intended objectives and result discussed above, the following tasks have to be carried out in several phases:

#### 1.5.1 Phase-1:

Implementation and design of a power system with wind energy source as renewable energy source. Analysis of voltage fluctuation, active and reactive power and power factor will be done without using D-STATCOM.

#### 1.5.2 Phase-2:

Implementation and design of D-STATCOM controller for the proposed system which will improve the voltage fluctuations and other tasks discussed earlier.

#### 1.5.3 Phase-3:

Implementing the desired D-STATCOM controller with the proposed system and analyzing the proposed system with D-STATCOM controller. Voltage fluctuations, active and reactive power and power factor values for the proposed system are analyzed with D-STATCOM controller.

#### 1.5.4 Phase-4:

Finally, the performance prosed system is analyzed with and without the D-STATCOM controller and the results are compared for both the cases.

The primary objective of this research is to improve voltage fluctuation in the power system and improving the active and reactive power and also improving the power factor of the power system.

### 1.6 Significance of Research:

It is vital as the load is increasing on daily basis as well as the variable nature of load which mostly attributes the non-linear behavior. The key effect of the non-linear behavior is the stability disturbance of system following a severe failure. To ensure the maximum power transfer by conventional means such PSS BR etc. are not close enough for modern power system due to their complexity. While the FACTS devices have been accounted for providing system operators with high flexibility of system parameters control to make sure that the maximum power is been delivered to the consumers [9]. In this thesis a comprehensive STATCOM controller is designed for the purpose of overcoming voltage fluctuation and also for the improvement of power factor of power system.

## Literature Review

### 2.1 Introduction

We discuss the basic prime knowledge and the basic principle of operation of FACTS devices. Moreover, it includes the short overview of the dq transformation. The performance of different FACTS devices is also being discussed to show how the system parameters are controlled for better system operation. Finally, a detail review of work related to this research is discussed.

## 2.2 abc to dq frame transformation

Consider 3-phase electrical variables which are  $x_a$ ,  $x_b$  and  $x_c$  and can represent either current, voltage or flux linkage.

Now the 3-phase variables can be denoted by using a space vector  $\vec{x}$  in a 3-phase ( $abc$ ) stationary reference frame. The relationship between the space vector and its 3-phase variables can be seen in the figure below:

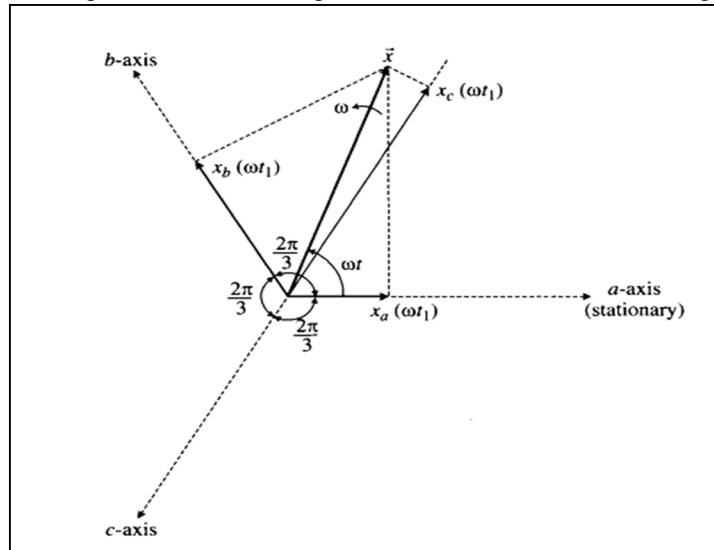

Figure 2.1: Space vector  $\vec{x}$  and its three-phase variables  $x_a$ ,  $x_b$ , and  $x_c$  [8]

Here  $\vec{x}$  rotates at the arbitrary speed  $\omega$  with respect to  $abc$  stationary frame. Now its phase values can be found by simply projecting  $\vec{x}$  to the corresponding to a-, b- and c-axis that are  $\frac{2\pi}{3}$  apart in the space.

Now the space vector  $\vec{x}$  can be written as:

$$\vec{x}(t) = \frac{2}{3} (x_a(t) + x_b(t)e^{j\frac{2\pi}{3}} + x_c(t)e^{-j\frac{2\pi}{3}})$$

Where

$$x_a(t) = A \cos(\omega t)$$

$$x_b(t) = A \cos\left(\omega t - \frac{2\pi}{3}\right)$$

$$x_c(t) = A \cos\left(\omega t - \frac{4\pi}{3}\right)$$

Where

A= Amplitude of each electrical phase

$\omega$ = Synchronous rotating phase

Now the 3-phase variables in the  $abc$  stationary frame can be transformed into more dynamic 2-variables in a reference frame defined by d (direct) & q (quadrature) axis that are perpendicular to each other.

The  $dq$ -axis frame has an arbitrary position with respect to the  $abc$ -axis stationary frame given by the angle  $\theta$  between the a-axis and b-axis. The  $dq$ -axis frame rotates in space at an arbitrary speed  $\omega$ , which relates to  $\theta$  by

$$\omega = \frac{d\theta}{dt}$$

To transform variables in the  $abc$  stationary frame to the  $dq$  rotating frame, simple trigonometric functions can be derived from the orthogonal projection of the  $x_a$ ,  $x_b$ , and  $x_c$  variables to the  $dq$ -axis.

The sum of all projections on the d-axis corresponds to the transformed  $x_d$ , given as;

$$x_d = x_a \cos \theta + x_b \cos\left(\frac{2\pi}{3} - \theta\right) + x_c \cos\left(\frac{4\pi}{3} - \theta\right)$$

This can be written as;

$$x_d = x_a \cos \theta + x_b \cos\left(\theta - \frac{2\pi}{3}\right) + x_c \cos\left(\theta - \frac{4\pi}{3}\right)$$

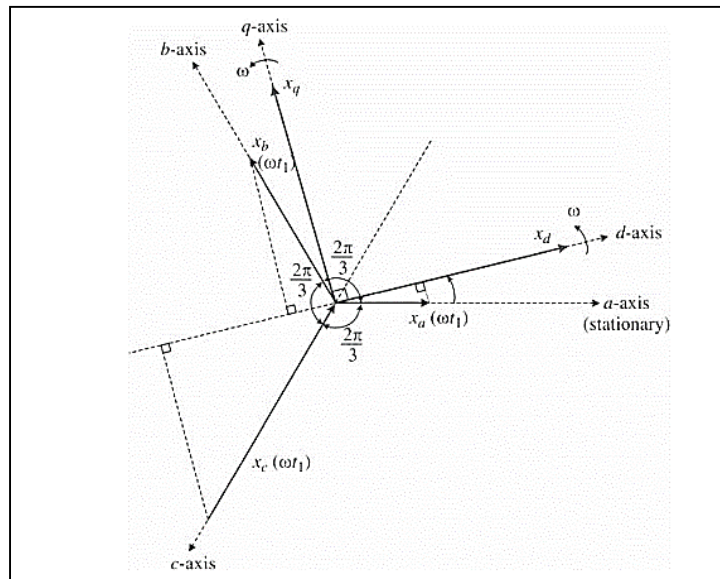

Figure 2.2: Transformation of variables in the three-phase (*abc*) stationary frame to the two phase (*dq*) arbitrary frame [8].

Similarly, the transformation of the *abc* variables into the *q*-axis can be performed. The transformation of the *abc* variables to the *dq* frames, referred to as *abc* to *dq* transformation, can be expressed in a matrix form;

$$\begin{bmatrix} x_d \\ x_q \end{bmatrix} = \frac{2}{3} \begin{bmatrix} \cos \theta & \cos(\theta - 2\pi/3) & \cos(\theta - 4\pi/3) \\ -\sin \theta & -\sin(\theta - 2\pi/3) & -\sin(\theta - 4\pi/3) \end{bmatrix} \begin{bmatrix} x_a \\ x_b \\ x_c \end{bmatrix}$$

Here:

A coefficient of 2/3 is arbitrarily added to the equation. The commonly used value is 2/3. The main advantage of using 2/3 is that the magnitude of the two-phase voltages is equal to that of the three-phase voltages after the transformation [8].

### 2.3 Flexible AC Transmission System (FACTS)

The Idea on which FACTS devices are based is that they are power-electronic-based devices that can control power system network parameters such as current, voltage, and impedance, such effectively compensate voltage sag. FACTS devices, like STATCOM and SVC which are well-developed mature technologies which have been extensively used in power.

The shunt type of FACTS controller is very efficient in improving the voltage profile of a specified bus, increase the power damping oscillation and improve the transient stability of system during disturbance. Some of the examples of the shunt type FACTS controllers are Static Synchronous Compensator (STATCOM) and Static VAR Compensator (SVC)

The series type of FACTS controller is useful in decreasing voltage fluctuation and thus increasing the voltage stability, improves the power factor of the system and also helps in increases the power oscillation of power system during disturbance.

The joint shunt-series type of the FACTS controller offers more than one function and capability at a time due to which several problems have been overcome faced by the power industry. Some of the examples of shunt-series type of FACTS devices are Interline Power Flow Controller (IPFC) and also Unified Power Flow Controller (UPFC) [3].

#### 2.3.1 FACTS Concept

The shunt type pf FACTS devices operates on the simple concept of steady state transfer of voltage level and power level across the transmission line which can be organized by using proper reactive shunt compensators. While linked to the power system, the capacitors produce reactive power while inductors (or reactors) absorbs, depending on the need of the power system. For effective operation of shunt controller, mechanical switches are used with VAR generator and absorber to control the reactive power generation and absorption [3]. Actually the shunt connected FACTS controllers are divided into three types which are as follow:

- i. Variable impedance
- ii. Hybrid.
- iii. Switching convertor.

### 2.3.2 Principal of FACT Controllers:

Numerous kinds of source and inverter circuit have been recommended and inspected. The dc-voltage source converter (VSC) is the type of converter that has been acknowledged most consideration is in the applied realization of the D-STATCOM principle. It is a very simple inverter that produces a square voltage waveform as it switches the direct voltage source on and off. The inverter must use either conventional thyristors with forced commutation, or it must use devices which can be turned off as well as turned on, such as gate turn-off (GTO) thyristors, which are been used and applied for many years in drives and also for industrial uses. Also a new generation of devices which requires less energy for switching process comprises of Integrated Gate Bipolar Transistor (IGBT), Integrated Gate Commutated Thyristors (IGCT) and MOS-Controlled Thyristors (MCT).

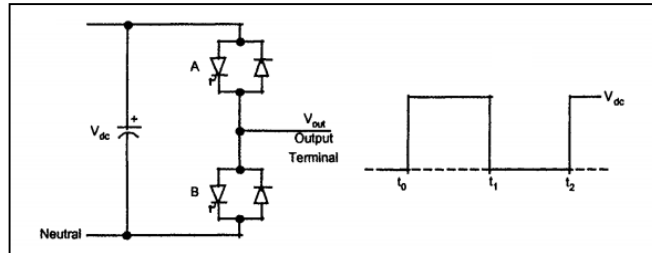

Figure 2.3: 2-level Voltage Source Inverter [10]

When a voltage source converter (VSC) is connected to the transmission system then it uses the transmission line frequency for its operation in order to generate a stable set of sinusoidal waveforms of voltage. Thus, the VSC connected to a transmission system have got only two (2) options of operation, firstly is that it can fluctuate the phase angle and magnitude of its output voltage according to the power system's voltage [5].

## 2.4 Introduction to D-STATCOM

When the D-STATCOM is applied to the distribution system it is called D-STATCOM (Distribution-STACOM). Its configuration is the same or with small modifications of the D-STATCOM that is applied to the distribution network at low and medium voltage. It operates in a similar manner as the D-STATCOM, with the active power flow controlled by the angle between the AC system and AC output converter voltages and the reactive power flow controlled by the difference between the magnitudes of these voltages.

### 2.4.1 Function of D-STATCOM:

D-STATCOM is a shunt connected compensating device that is capable of absorbing and supplying reactive power to the system in order to maintain output, it also improves steady state stability of the network [11].

D-STATCOM deals with reactive power support in order to provide constant system voltages and it also has ability to dump out the system oscillations due to internal disturbances. Both capacitive and inductive type of reactive power can be supplied by D-STATCOM for the improvement of power quality of the system [12, 13].

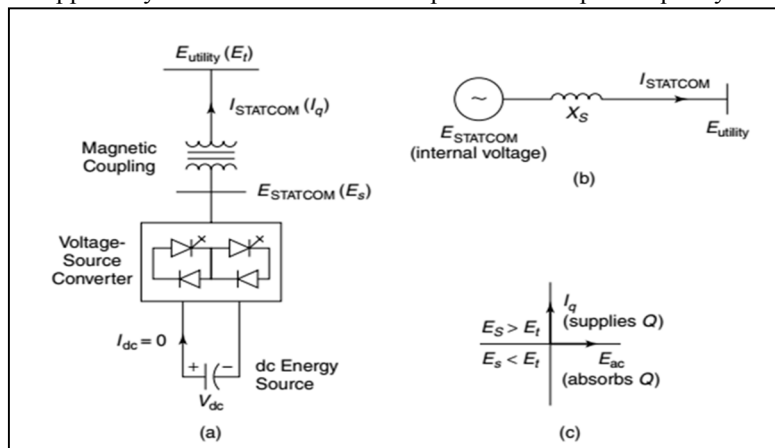

Figure 2.4: (a) D-STATCOM power circuit diagram; (b) D-STATCOM equivalent circuit diagram; (c) D-STATCOM power exchange diagram [10]

### 2.4.2 Basic Concept of the D-STATCOM

A STATCOM employed at distribution side or at load side is called D-STATCOM. The D-STATCOM consists of a VSC, a DC bus capacitor, a coupling transformer connected in shunt with the ac system. STATCOM at transmission level control only the reactive power compensation and provide voltage support. Whereas the D-STATCOM is employed at the distribution level or load side and it also behaves as shunt active filter. A D-STATCOM consists of GTO/IGBT based VSI connected to the power system through coupling transformer [14].

D-STATCOM employs either a voltage source inverter (VSI) or current source inverter (CSI) with reactive power storage as capacitor or inductor respectively.

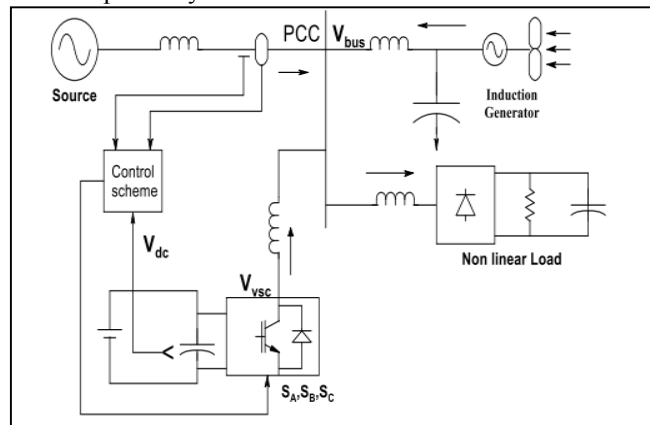

Figure 2.5: Schematic diagram of D-STATCOM [15]

The current generated by D-STATCOM correct the voltage sag by adjusting voltage drop across system impedances. When current injected by the D-STATCOM is kept in quadrature with the system voltage, so desired voltage correction can be achieved without injecting any active power to the system [15].

#### 2.4.3 Principal of Operation of D-STATCOM

The operation of D-STATCOM involves the exchangeable amount of reactive power (capacitive or inductive) between the power system and D-STATCOM, can be adjusted or set by monitoring the output voltage of D-STATCOM with respect to the voltage of system. The D-STATCOM will supply reactive power in case when the value of Q is positive with respect to the system and on the other hand D-STATCOM will absorb the reactive power from system when Q is negative. The generation of reactive power is being achieved through charging and discharging of the energy bank capacitor [11, 16, 17]. The reactive power deliver by the D-STATCOM to system can be represented by the following given equation:

$$Q = \frac{V_{STATCOM}^2 - V_s^2}{X} \quad (1)$$

In above eq: (1);

$Q$  = Reactive power deliver by D-STATCOM

$V_{STATCOM}$  = Amplitude of output voltage of D-STATCOM

$V_s$  = Amplitude of the System's voltage

$X$  = Equivalent Reactance between the D-STATCOM and the system.

#### 2.4.4 Operating characteristics of D-STATCOM

$V-I$  characteristics of STATCOM is presented in Figure 2.5. D-STATCOM reactive power output does not depend on voltage at the bus. So even in case of very low bus voltage, D-STATCOM can work with its full capacity unlike SVC whose performance degrades with lower bus voltage. D-STATCOM is preferred over SVC at locations where voltage goes too low or drops down very fast, so instant control is required [18]. For unbalanced voltage control by SVCs a 3rd harmonic filter is required. It occupies a large area. Hence it is generally avoided by utilities. Whereas, STATCOM does not have any low order filter requirements and hence is a preferred solution for mitigating unbalance. Superiority of D-STATCOM over SVC is presented in [19].

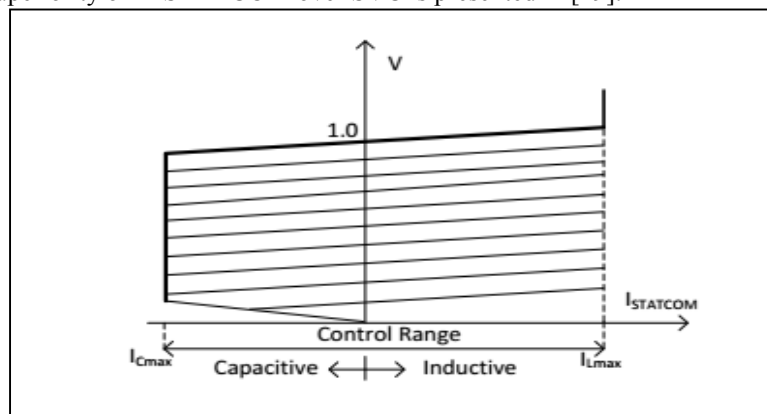

Figure 2.6: D-STATCOM operating characteristics [20]

#### 2.4.5 D-STATCOM Control Strategies

The heart of the D-STATCOM used for compensation of the power system is its control system and its response to the dynamic change of the load depends on the methodology used for its control. It has been observed that all the schemes broadly fall into the following categories: phase shift control, carrier based PWM control, and carrier less hysteresis control

### 2.5 Previous Studies and Research

D-STATCOM consists of a Voltage Sourced Inverter (VSI) without any DC voltage source at dc-link. There are different inverter configurations available for STATCOM such as multi-level inverter [21], modular multi-level inverter [22], six-pulse three phase inverter [23], [24], cascaded converter based STATCOM [25], cascaded H-bridge converter with star configuration [26], [27], three level neutral point clamped (NPC) inverter [28] etc.

There are various modulation strategies in literature for inverters such as symmetrical multiple pulse modulation, sinusoidal pulse width modulation (SPWM), selective harmonic elimination pulse width modulation (SHEPWM) [29] etc. No control over harmonics is present in symmetrical multiple pulse modulation technique. Lower order harmonics can be successfully removed with SHEPWM. However, probability of derating of converter is higher.

Being an expensive device, D-STATCOMs are typically installed for fast voltage regulation or power factor correction in networks where voltage excursion is large [23]. There is a trend in recent years to add more features in STATCOM to increase its versatility for various purposes and with other power sources like with petroleum industries and high speed railway [30], [22] and [31]. Following this, a co-ordination of D-STATCOM with other power sources is addressed in [31]. In case of unbalanced load, negative sequence current flows through compensator and introduces 2<sup>nd</sup> harmonic voltage component on DC-link. If not amended, it will cause 3<sup>rd</sup> harmonic current component on the AC side thus, deteriorating the STATCOM performance [32]. Furthermore, a severe imbalance may cause large negative sequence current on AC side forcing D-STATCOM to go offline and restricting its reactive power support.

It can be hereby seen that various D-STATCOM controls and other FACTS have been suggested in literature for achieving either voltage balancing, active and reactive power improvement and power factor improvement, independently, or in a combination of two functions. But it can be seen that no such D-STATCOM controller seems to have been developed which can analyze and implement the three issues instantaneously.

## Methodology

### 3.1 Introduction

The methodology approach in simulating and analyzing the test system which contains wind energy source as renewable energy source and non-linear load is being studied. The system is first analyzed without STATCOM and then with STATCOM using MATLAB Sim Power System Toolbox (MATLAB) software. This software makes the analysis of load flow, voltage fluctuation and power factor accurate and easily.

### 3.2 D-STATCOM implementation in Simulink

A comprehensive STATCOM is being modelled in Simulink with an appropriate gain setup also here we use  $abc$  to  $dq$  transformation which transform the  $abc$  to  $dq$  transformation. The advantage of this conversion i.e. from  $abc$  to  $dq$  transformation is that it makes equations easier also  $dq$  has perfect orientation so the transformation is being done and a block of  $abc$  to  $dq$  transformation is being used.

### 3.3 Detailed Versus Average Model

When modeling VSC-based energy conversion systems in Simulink, you can use two types of models, depending on the range of frequencies to be represented: the detailed model and the average model.

#### ■ The detailed model

It includes detailed representation of power electronic IGBT converters. In order to achieve an acceptable accuracy, the model must be discretized at a relatively small time step (5 microseconds). This model is well suited for observing harmonics and control system dynamic performance over relatively short periods of times (typically hundreds of milliseconds to one second).

#### ■ The average model

In this type of model, the IGBT Voltage-Sourced Converters (VSC) are represented by equivalent voltage sources generating the AC voltage averaged over one cycle of the switching frequency. This model represents harmonics, but the dynamics resulting from control system and power system interaction is preserved. This model allows using much larger time steps (typically 40-50 microseconds), thus allowing simulations of several seconds.



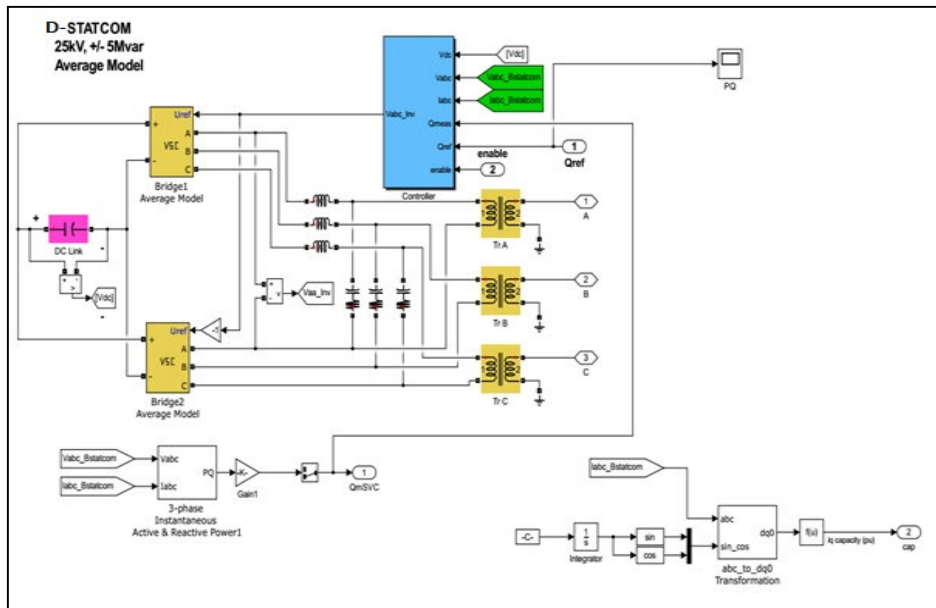

Figure 3.1: D-STATCOM implementation in Simulink

### 3.4 Load implementation in Simulink:

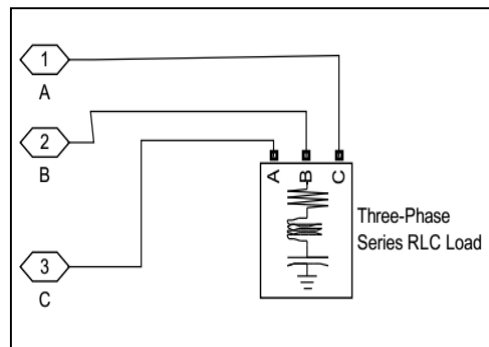

Figure 3.2: Load implementation in Simulink

The load used in the test power system is non-linear load. The nature of non-linear load is to create harmonics and produce distortion in current and also voltage waveforms.

### 3.5 Wind Generator model in Simulink:

The wind turbine model is centered on the steady-state power characteristics of the turbine.

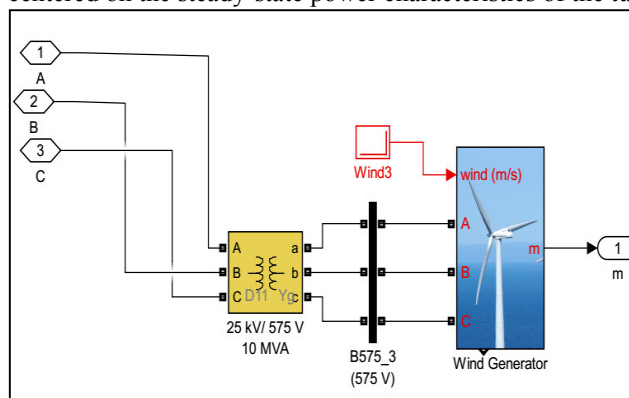

Figure 3.3: Wind Generator implementation in Simulink

### 3.6 Summarized Flow Chart

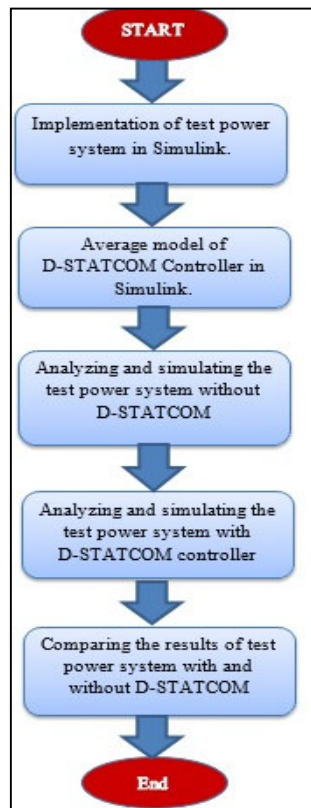

Figure 3.4: The flow chart of methodology adopted

## Simulation and Results

### 4.1 Introduction

The results obtained from the simulation done in MATLAB Sim Power System are presented here. The simulation was involving the test power system without the consideration of any D-STATCOM controller, meaning it was just to measure the system performance during no D-STATCOM controller. Then, the system performance was measured with D-STATCOM controller taken into account.

## 4.2 Simulation and Evaluation of test power system performance without D-STATCOM Controller

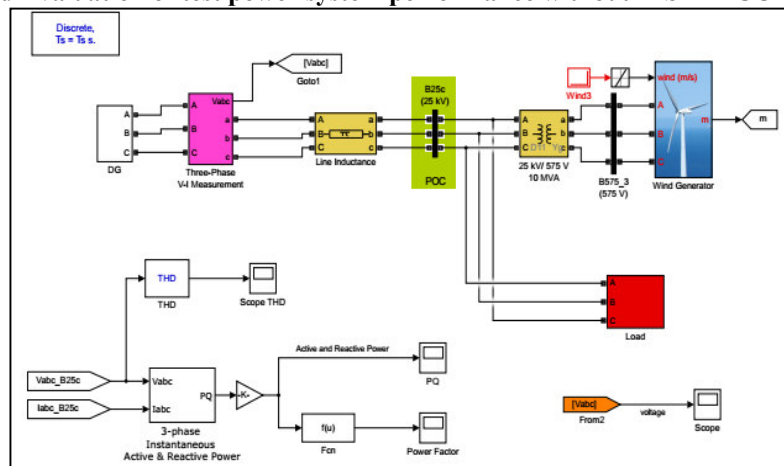

Figure 4.1: Simulink model of test power system without D-STATCOM Controller

### 4.2.1 Grid voltages without D-STATCOM:

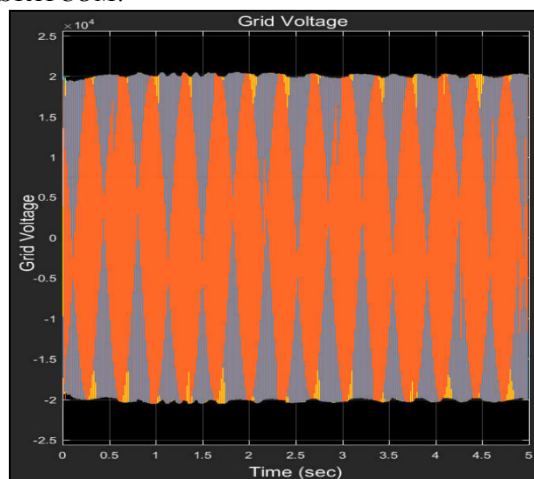

Figure 4.2: Grid voltages without D-STATCOM

Here these are the voltages of point of coupling (PCC) of wind generated voltage and also the Grid generated voltage.

### 4.2.2 Active and Reactive power without D-STATCOM:

When there is no D-STATCOM controller in the power system the active and reactive power of the power system are below:

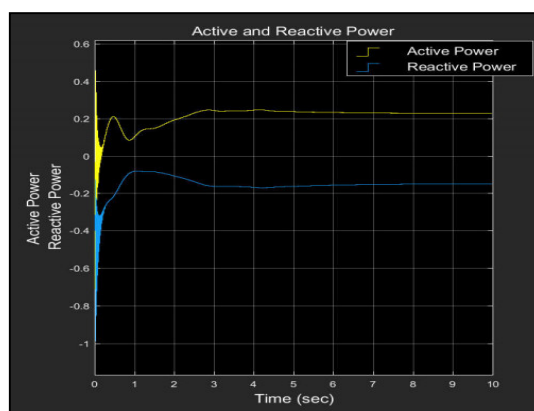

Figure 4.3: Active and Reactive power without D-STATCOM

#### 4.2.3 Total Harmonic Distortion without D-STATCOM:

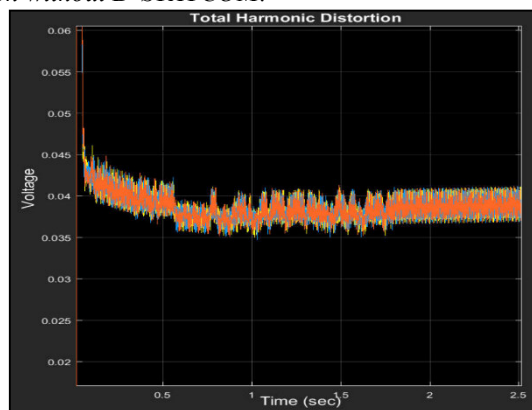

Figure 4.4: Total Harmonic Distortion without D-STATCOM

#### 4.2.4 Power Factor without D-STATCOM:

- The Improvement of power factor i.e. reaching of power factor to unity is of importance to both consumers and generating stations.
- A power factor of one or "unity power factor" is the goal of any electric utility company since if the power factor is less than one, they have to supply more current to the user.
- As a result, an industrial facility will be charged a penalty if its power factor is much different from 1. Here it can see that the power factor of test power system without D-STATCOM is less than unity.

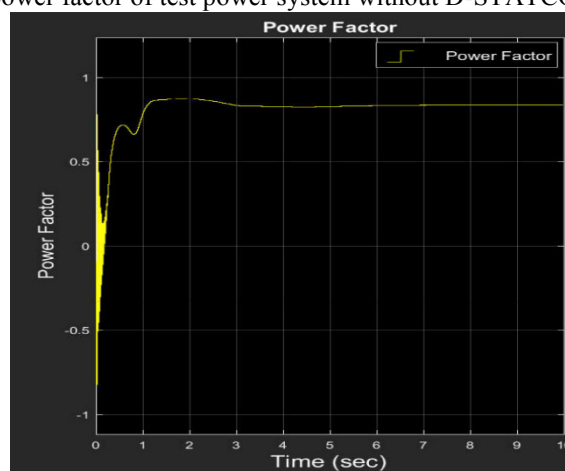

Figure 4.5: Power Factor without D-STATCOM

### 4.3 Simulation and Evaluation of test power system performance with D-STATCOM Controller

Using the D-STATCOM controller and adding it to the test power system and analyzing the different aspects of power system.

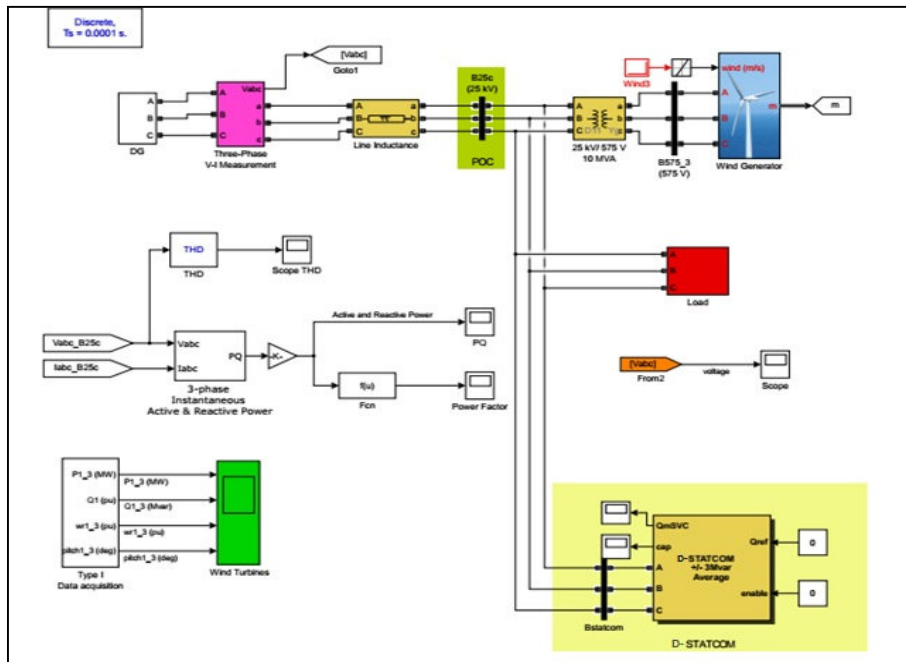

Figure 4.6: Simulink model test power system with D-STATCOM Controller

#### 4.3.1 Grid voltages with D-STATCOM:

Grid voltage after the coupling of D-STATCOM at PCC become sinusoidal without distortion and voltage Sag/Swell. Now the sag is 0% (voltage magnitude is 1 p.u) while its value was 40% without using D-STATCOM.

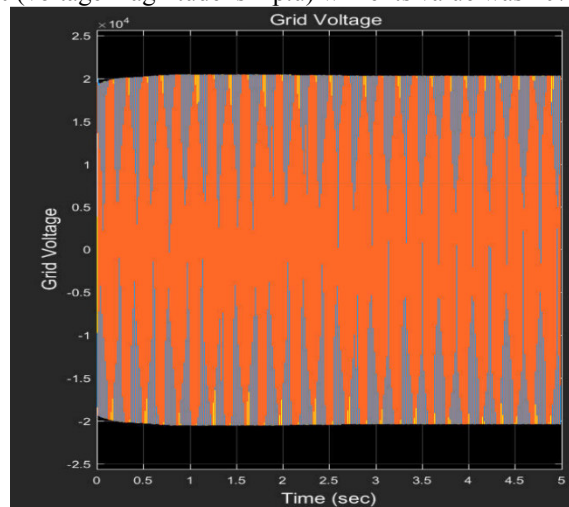

Figure 4.7: Grid voltages with D-STATCOM

#### 4.3.2 Total Harmonic Distortion with D-STATCOM:

We can clearly see that total harmonic distortion has been successfully been improved by adding D-STATCOM controller to the power system.

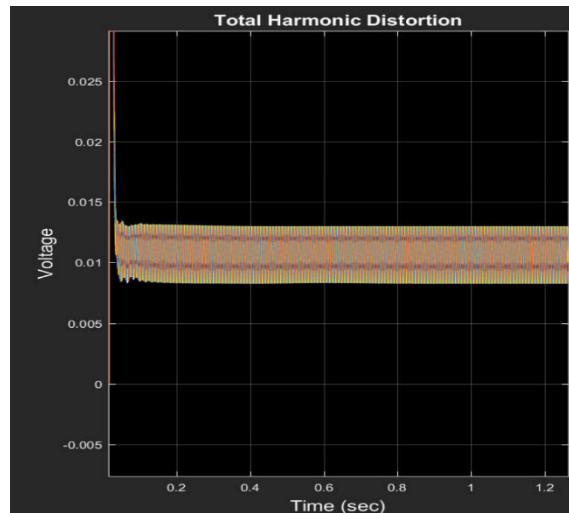

Figure 4.8: Total Harmonic Distortion with D-STATCOM

#### 4.3.3 Active and Reactive power with D-STATCOM:

By adding D-STATCOM controller to the power system the reactive power of the power system is increased and has reached to almost 0.

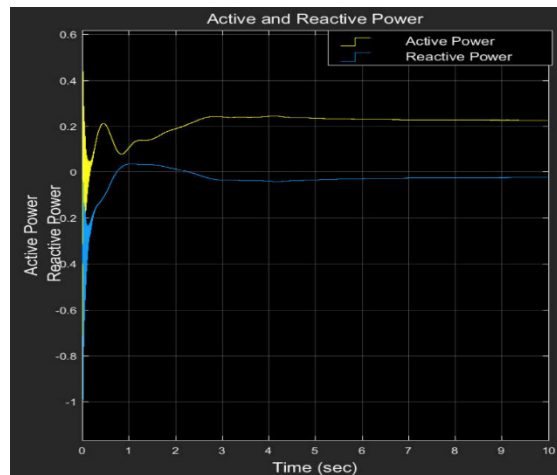

Figure 4.9: Active and Reactive power with D-STATCOM

#### 4.3.4 Power Factor with D-STATCOM:

It can be clearly seen that after introducing STATCOM controller in the test power system the power factor of the power system which was previously less than 1 has now been improved and is almost 1.

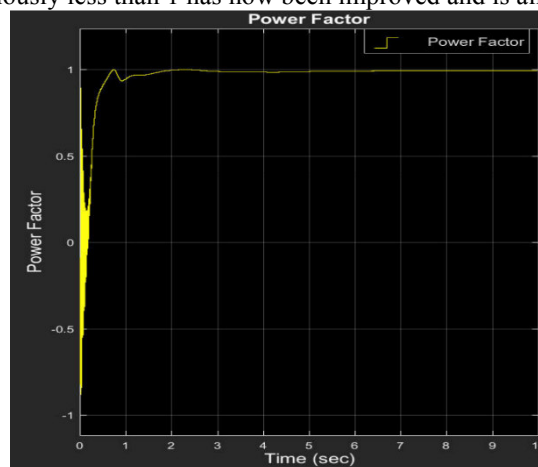

Figure 4.10: Power Factor with D-STATCOM

## Conclusion

### 5.1 Research Conclusion:

The purpose of this research was to identify the effect of comprehensive D-STATCOM Controller on the power system in terms of voltage stability, active and reactive power improvement and power factor improvement. In this research  $dq$  transformation was being developed as  $dq$  transformation has perfect orientation and can be used for control techniques also it reduced the complexity of  $abc$  transform.

As a conclusion, a comprehensive D-STATCOM controller was successful in removing voltage fluctuation from the power system and improving active and reactive power and also improving the power factor of the power system.

### 5.2 Achievements of Research

This research has been carried out successfully. It has been proved from the analysis of different plots that by introducing D-STATCOM controller to the power system voltage fluctuation and other problems including power factor improvement and active and reactive power improvement can successfully be achieved. When if D-STATCOM is placed in power system, it will give better results in the improvement of power quality and reduced power loss which is possible due to fluctuation and oscillations produced due to wind energy variable nature. But when the system has no D-STATCOM the power system will have losses.

### 5.3 Recommendation

There are a few recommendations for future work for improvement of this research work.

- i. Test the system using others FACTS controllers such as SVC, UPFC and TCSC because different device can show different effect for voltage fluctuation and also power factor improvement.
- ii. Test the system using other simulation software like PSCAD, POWERWORLD, and other software.
- iii. Test the D-STATCOM controller on a very large network, to view its capability
- iv. Develop new method to improve power system delivery quality for reduce losses.

## References

- [1] V. Mahajan, "Power System Stability Improvement with Flexible A.C. Transmission System (FACTS) Controller," *Power System Technology and IEEE Power India Conference, 2008. POWERCON 2008. Joint International Conference on*, New Delhi, 2008, pp. 1-7.
- [2] R.J. Nelson, J-Bian, D.G.Ramey, T.A.Lemak, T-R-Reitman, J.E.Hill "Transient Stability enhancement with FACTS controllers," *Sixth International Conference on AC & DC Transmission, No.423. 1997.*
- [3] P. H. Ashmole, "Introduction to 'FACTS'," *Flexible AC Transmission Systems (FACTS) - The Key to Increased Utilisation of Power Systems, IEE Colloquium on (Digest No.1994/005)*, London, 1994, pp. 1/1-1/2.
- [4] C. C. Davidson, "Power transmission with power electronics," *Power Electronics and Applications (EPE 2011), Proceedings of the 2011-14th European Conference on*, Birmingham, 2011, pp. 1-10.
- [5] N.G. Hingorani and L. Gyugyi, "Understanding FACTS concepts and technology of flexible AC transmission systems," *IEEE Press*, New York, 2000.
- [6] Nallagalva, S.Kumar, M.K Kirar, and G. Agnihotri. "Transient Stability Analysis of the IEEE 9-Bus Electric Power System", *International Journal of Scientific Engineering and Technology 1.3 (2012): 161-166.*
- [7] A. Kumar and G. Priya, "Power system stability enhancement using FACTS controllers," *Emerging Trends in Electrical Engineering and Energy Management (ICETEEEM), 2012 International Conference on*, Chennai, 2012, pp. 84-87.
- [8] Bin Wu, Y. Lang, N. Zargari and S. Kouro, "Power conversion and control of wind energy systems" *IEEE Press 2011.*
- [9] Pavlos S. Georgilakis and Peter G. Vernados, "Flexible AC Transmission System Controllers: An Evaluation," *Materials Science Forum, Trans Tech Publications*, Switzerland, Vol. 670, pp 399-406, 2011.
- [10] <http://www.rioi.com/open-access/power-quality-improvement-in-dtcbased-induction-motor-drive-using-multilevel-statcom.php?aid=41777>
- [11] K.K. Sen, "STATCOM-static synchronous compensator theory, modeling, and applications," in *Proc. IEEE Power Eng. Soc. Winter Meeting*, 1999, vol. 2, pp. 1177-1183.
- [12] Z. Chen and E. Spooner, "Grid power quality with variable speed wind turbines," in *IEEE Transactions on Energy Conversion*, vol. 16, no. 2, pp. 148-154, Jun 2001.
- [13] S. W. Mohod and M. V. Aware, "Power quality issues & its mitigation technique in wind energy conversion," in *Proc. of IEEE Int. Conf. Quality Power & Harmonic*, Wollongong, Australia, 2008.
- [14] V.Kumbha, N.Sumanthi, "Power Quality improvement of distribution lines using DSTATCOM under various loading condition," *international journal of Modern Engineering Research (IJMER)*, vol.2, Issue.5, sept.2012, pp-3451-3457

- [15] A.Ananda Kumar, G.Ganeshwar Kumar “Power Compensation at Distribuion Level using a VSC based STATCOM,” *International Journal of Engineering Research & Technology (IJERT)* ISSN:2278-0181, vol.1, Issue.5, July-2012
- [16] A.Pateriya, N.Saxena and M.Tiwari, “Transfer Capability Enhancement of Transmission Line using Static Synchronous Compensator (STATCOM),” *International Journal of Advanced Computer Research*. Volume-2 Number-4 Issue-7 December-2012. 83-88.
- [17] M. Molinas, S. Vazquez, T. Takaku, J.M. Carrasco, R. Shimada, T. Undeland, “Improvement of transient stability margin in power systems with integrated wind generation using a STATCOM: An experimental verification,” *International Conference on Future Power Systems*, 16-18 Nov. 2005.
- [18] S. Teleke, A. Yazdani, B. Gudimetla, J. Enslin and J. Castaneda, "Application of STATCOM for power quality improvement," *Power Systems Conference and Exposition (PSCE)*, 2011 IEEE/PES, Phoenix, AZ, 2011, pp. 1-6.
- [19] M.G. Kashani, S. Babaei, S. Bhattacharya, "SVC and STATCOM application in Electric Arc Furnace efficiency improvement," in Proc. 4th IEEE International Symposium on Power Electronics for Distributed Generation Systems (PEDG), pp. 1-7, 8-11 July 2013.
- [20] Singh, B., Verma, K. S., Mishra, P., Maheshwari, R., Srivastava, U., & Baranwal, A. (2012). "Introduction to FACTS Controllers" *A Technological Literature Survey. International Journal of Automation and Power Engineering*, 1(9), 193-234.
- [21] C. Hochgraf and R. H. Lasseter, "Statcom controls for operation with unbalanced voltages," *IEEE Trans. Power Del.*, vol. 13, no. 2, pp. 538– 544, Apr. 1998.
- [22] P. W. Lehn, "Exact modeling of the voltage source converter," *IEEE Trans. Power Del.*, vol. 17, no. 1, pp. 217–222, Jan. 2002.
- [23] R. M. Mathur and R.K. Varma, "Thyristor based FACTS controllers for Electrical transmission systems," *IEEE press* 2002.
- [24] <http://www.abb.ca/>
- [25] Xiong, Liansong; Zhuo, Fang; Zhu, Minghua, "Study on the compound cascaded STATCOM and compensating for 3-phase unbalanced loads," *Applied Power Electronics Conference and Exposition (APEC), 2013 Twenty-Eighth Annual IEEE*, pp.3209-3215, 17-21 March 2013.
- [26] Q. Song and W. Liu "Control of a cascade STATCOM with star configuration under unbalanced conditions" *IEEE Trans. Power Elec.*, vol. 24, no. 1, Jan. 2009.
- [27] Shih-Feng Chou; Bo-Siang Wang; Sheng-Wan Chen; Chia-Tse Lee; Po-Tai Cheng; Akagi, H.; Barbosa, P., "Average power balancing control of a STATCOM based on the cascaded H-bridge PWM converter with star configuration," in Proc. 2013 IEEE Energy Conversion Congress and Exposition (ECCE), pp.970-977, 15-19 Sept. 2013
- [28] A. Yazdani and R. Irvani, "Voltage sourced converters in power system Modeling, control, and application" *IEEE WILEY press* 2010.
- [29] Bingjie Zhao; Xiaojie Wu; Xiao Fu; Peng Dai, "A Novel 12-Pulse 3-Level Inverter for STATCOM Using Selective Harmonic Elimination Modulation," in Proc. 2010 Asia-Pacific Power and Energy Engineering Conference (APPEEC), pp.1-5, 28-31 March 2010
- [30] G. Escobar, A. M. Stankovic', and P. Mattavelli, "An adaptive controller in stationary reference frame for D-StatCom unbalanced operation," *IEEE Trans. Ind. Electron.*, vol. 51, no. 2, pp. 401–409, Apr. 2004.
- [31] J.M. Guerrero, Poh Chiang Loh; Tzung-Lin Lee; M. Chandorkar, "Advanced Control Architectures for Intelligent Microgrids—Part II: Power Quality, Energy Storage, and AC/DC Microgrids," *IEEE Transactions on Industrial Electronics*, vol. 60, no. 4, pp. 1263-1270, April 2013.
- [32] B. Blazic and I. Papic, "Improved D-StatCom control for operation with unbalanced currents and voltages," *IEEE Trans. Power Del.*, vol. 21, no. 1, pp. 225–233, Jan. 2006.
- [33] Kumkratug, P., 2011, "Improving power system transient stability with static synchronous series compensator", *Am. J. Applied Sci.*, 8: 77-81.