

Design, Construction and Performance Evaluation of a Propane Conversion Kit

O.S Olaoye, L. Osunmakinde, O. A. Ibitowa and O. D. Abodunrin
Mechanical Engineering Department, Ladoke Akintola University of Technology,
P.M.B. 4000, Ogbomoso, Nigeria
osolaoye@lautech.edu.ng and olaoyeos@gmail.com

ABSTRACT

The electricity demand in Nigeria is far beyond what is generated and supply is epileptic in nature. Erratic power supply has led to the use of generator to maintain constant supply of electricity at homes and offices. The incessant hike and artificial scarcity of petrol and diesel in Nigeria have led to looking for an alternative fuel that can be used to generate electricity and that is propane. This paper report on design, construction and testing of C1 conversion kit for 1.7 kVA generator. This enables generator to use both petrol and propane as source of fuel. The aim is to design a kit that is simple and affordable for people. The generator was tested with petrol and propane while carrying 288 Watt of load for 4 hour 15 minutes. The results show 4.3% CO₂ reduction when petrol was used as fuel and 80.66% CO reduction when propane was used. An average of 0.21kg/h of propane was used as against 0.83kg/h of petrol for the same load. Propane gas is not only economical but also saver and environmental friendly. Moreover, the kit was simple to install and used.

Keywords: Generator, Propane, C1 converter, economical, affordable

INTRODUCTION

Energy plays a significant role in the socio-economic development of a nation. It enhances the standard of living and the quality of life of the population. One of the major problems in Nigeria today is energy generation and distributions. The electricity demand in Nigeria is far beyond what is generated and supply is epileptic in nature. The acute shortage is hindering development since there is a strong relationship between socio-economic development and availability of electricity. The per capital electricity generation in Nigeria is 0.05 that is low (Olugbenga *et al.*, 2013). The resent statistic report shows that about 70% of Nigerian rely on two structures power generation, that is PHCN and generator(Ekpo, 2009). Despite the fact that Nigeria is endowed with significant renewable energy resources including large and small hydroelectric power resources, solar energy, wind, potentials for hydrogen utilization and development of geothermal and ocean(ECN, 2005; Alamu *et al.*, 2007). Majority of Nigerians are using generator to argument the erratic power supply, both at homes and offices.

Generator is any machine that converts mechanical energy to electricity (Klempner and Kerszenbaun,2004). It could either be a diesel generator, petrol generator or gas generator. The incessant hike and artificial scarcity of petrol and diesel in Nigeria have great effect on both the economic and social life of the populace. However, despite the scarcity of this product, electricity can still be generated at a lower price. Availability of natural gas in abundances (estimated to be 187 trillion cubic feet, Oyem, 2013) is a hope of generating electricity without any hindrance or burden on Nigeria citizens.

Environmental benefits offered by propane generator in comparison to either diesel or gasoline generator include reduced sulfur oxides emissions, ultra-low emissions of particulates, carbon monoxide and volatile organic compounds. Typical propane gas burns much cleaner than gasoline, heating oil and diesel, with less carbon dioxide per BTU than petroleum based fuels. In addition, propane cuts emissions of toxins and carcinogens like benzene by up to 96% when used in place of gasoline. Its exhaust creates 60 - 70% fewer smog hydrocarbons than gasoline and 12% less carbon dioxide, about 20% less nitrous oxide (N₂O) and as much as 60% less carbon monoxide than gasoline (Markita, 2008).

Propane is an energy rich gas that is related to petroleum and natural gas (Gaynor, 2002). It is a three carbon alkaline derived during the processing of oil and natural gas. Nigeria is endowed, according to (EIA, 2007) it has an estimated 187 trillion cubic feet (tcf) of proven natural gas reserves, the seventh largest reserves in the world. Propane was first identified by Dr. Water Snelling, in 1910. Snelling while working on liquefied gas, he discovered that a bottle full of propane was sufficient to light a home for three weeks (Kevin, 2012). He

invented ways to liquefied gas while refining natural oil. Limited studies were, however, found in the literature on the use of propane as fuel in a generator. This study reports the economic value, using propane as fuel substitute to generate electricity through design and construction of conversion kits and its environmental benefits.

MATERIALS AND METHODS

Conversion kits vary for different KVA's generators. The generator used for this project is a 1.7KVA, therefore a conversion kits of C1 was fabricated. The parts required are of two types: standard part and the designed part. This two parts are coupled together to make the propane conversion kit, which will allow the generator to run on propane gas. The standard parts that were gotten from the market are the nipple joint, parker brass ball valve, fuel controller whose diameter assume the size of the medium joint. It serves as a control valve because it helps to open and close the pipe that conveys the gas to the carburetor. This serves as the opening and closing of gaseous fuel into the generator carburetor. Also, stud extenders was bought and used to extend the length over which the engine carburetor and the adaptor will seat.

The designed parts include the adaptor and medium joint which were designed and fabricated carefully from selected steel material. Steel was chosen because it has a unique combination of attractive properties which ranges from mid weight, high strength, superior malleability, easy machining, and excellent corrosion resistance and its cheapness. In the design of adaptor, the size of the carburetor opening was measured. The carburetor venturi was measured so as to know the size and how to fabricate the kit that will convert the generator to run on propane. After taking note of this measurements and sizes, machining was carried out on the material needed for the fabrication. In other words the adaptor was fabricated based on the size of the carburetor venturi.

The diameter of the joint was determined based on the mass flow rate equation as it became necessary to determine the flow rate, diameter, area and velocity at which the gas will be moving from the cylinder jar into the engine carburetor.

The flow rate through a pipe is given as (Frank, 2004):

$$Q = A.V \quad \dots\dots\dots 1$$

Where Q = flow rate (m³/s)

A = area of the joint in m²

V = gas velocity in m/s

Speed of various gases can be calculated using (Myrtle, 2012):

$$S = \left(\frac{3RT}{M}\right)^{1/2} \quad \dots\dots\dots 2$$

Where M = molar mass of the gas molecule

T = temperature of the gas in kelvin

R = ideal gas constant

Since propane has a chemical formula of C₃H₈, therefore the molar mass can be calculated.

Hence, the diameter of the medium joint, adaptor hole and the control valve is 20mm.

Hence the drawing and specifications is shown in figure 1:

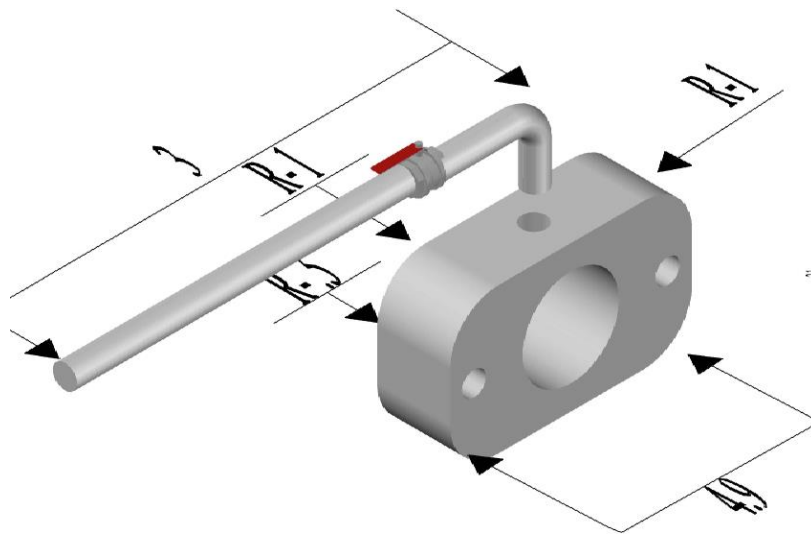

Figure 1: Propane Conversion Kit

The fabricated parts (that cost about ~~N~~ **6000.00**) and standard parts were coupled together and installed in the generator. The arrangement was done to allow both propane and petrol to be used alternatively. Then test was carried out when propane was used as source of fuel and when petrol was used under the same load condition. Analysis was done on quantity of fuel used, CO & CO₂ emission and cost for both petrol and propane.

Experimental Procedures

3.6 Kg of propane gas was carefully connected to 1.7 KVA generators with the help of the conversion kit. The nipple joint, parker brass ball valve, fuel controller were placed tightly. Stud extender was used to securely affirm the adaptor and carburetor to the generators. The set up was used to light up a room under load of 288 Watts for 4 hrs 5 minutes. The conversion kit arrangement to the generator enables it to run on either of the fuel used. The phase of the propane gas was closed which in turn open the phase of petrol. The generator was run again on load 288 Watts using petrol as fuel source for the same period as compared to gas. The experiments were repeated three times and air mixture sampling was measured using gas detector (Air Quality Meter AQ-9901SD) for CO and CO₂. The weight of propane gas and petrol was determined at the end of each trial using weighing scale and the average value of the fuel used in Kg was determined using this relation:

$$W_{pg} = \frac{W_{2a} - W_{1a} + W_{2b} - W_{1b} + W_{2c} - W_{1c}}{3} \dots\dots\dots 3$$

RESULTS AND DISCUSSIONS

Air mixture characterization

The air mixture produced by propane gas generator and gasoline, were analyzed for parts per million (PPM). The results obtained are presented in table 1-4. The propane gas generators having 978 ppm CO₂ and 212 ppm CO, while the CO₂ and CO for petrol are 936 ppm and 383 ppm respectively. This shows that there is 4.3% CO₂ reduction when petrol fuel was used while 80.66% CO reduction when propane gas was used. According to ASHRAE and OSHA standards, CO emission from petrol was more hazardous than that of propane (Table 6).

The CO₂ values for both fuels fall within concentrations typical of occupied indoor spaces with good air exchange the approved level (Table 5). Technically, it shows that propane gas produces cleaner fumes than petrol source.

Table 1: PPM of CO₂ in Propane Generator

CO ₂	PPM of propane	Temperature °C
	973	20.8
	980	20.8
	981	20.8

Average PPM of gas = *978 ppm*

Table 2: PPM of CO in Propane Generator

CO	PPM of propane	Temperature °C
	212	100
	216	100
	208	100

Average PPM of CO for gas = *212 ppm*

Table 3: PPM of CO₂ in Petrol Generator

CO ₂	PPM of petrol	Temperature °C
	935	20.8
	937	20.7
	936	20.8

Average PPM of CO₂for petrol = *936 ppm*

Table 4: PPM of CO in Petrol Generator

CO ₂	PPM of petrol	Temperature °C
	382	100
	384	100
	383	100

Average PPM of CO for petrol = *383 ppm*

Table 5: Standard PPM for CO₂ Safety Levels in Rooms

250-350ppm	Normal background concentration in outdoor ambient air
350-1,000ppm	Concentrations typical of occupied indoor spaces with good air exchange
1,000-2,000ppm	Complaints of drowsiness and poor air.
2,000-5,000 ppm	Headaches, sleepiness and stagnant, stale, stuffy air. Poor concentration, loss of attention, increased heart rate and slight nausea may also be present.
5,000	Workplace exposure limit (as 8-hour TWA) in most jurisdictions.
>40,000 ppm	Exposure may lead to serious oxygen deprivation resulting in permanent brain damage, coma, even death.

Source: ([http://www.kane.co.uk/tech-tips-faqs/359-what-are-safe-levels-of-CO-and-CO₂-in-rooms](http://www.kane.co.uk/tech-tips-faqs/359-what-are-safe-levels-of-CO-and-CO2-in-rooms))

Table 6: Standard PPM for CO Safety Levels in Rooms

9 ppm	CO Max prolonged exposure (ASHRAE standard)
35 ppm	CO Max exposure for 8 hour work day (OSHA)
35 - 800 ppm	CO Death within 2 to 3 hours
>12,800 ppm	CO Death within 1 to 3 minutes

Source: ([http://www.kane.co.uk/tech-tips-faqs/359-what-are-safe-levels-of-CO-and-CO₂-in-rooms](http://www.kane.co.uk/tech-tips-faqs/359-what-are-safe-levels-of-CO-and-CO2-in-rooms))

Economical value of used fuel

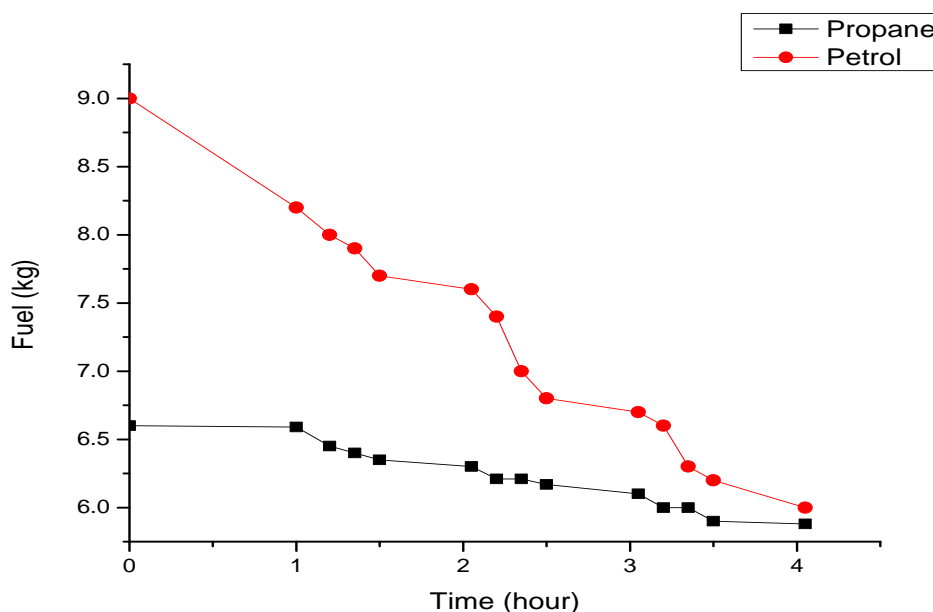

Figure 2: Graph of propane gas and petrol against time

From figure 2, the rate of petrol fuel expended in a generator is inversely proportional to time likewise propane gas too. But there is a clear difference at which this occurred. At the origin of the graph, (0,0) weight of the petrol was 9 Kg while that of propane gas was 6.6 Kg. After an hour of usage there is a sharp decline in weight of petrol compare to propane gas, this continue up to 2 hours of usage. The graph between 2 hours after and 3 hours shows a drastic reduction in petrol used which then later maintain a balance compared to propane gas. Propane gas is economical compared to petrol since 0.21 Kg/h propane gas was used to power 1.7KVA generator with load 288 Watts while 0.83 Kg/h petrol was used to power 1.7KVA generator respectively. The propane gas used to power 1.7KVA generator on load 288 Watts for an hour was 0.21 Kg which translates to ₦ 56.00 while for petrol is 0.83 Kg and translate to ₦ 89.24K Nigeria currency respectively. This implies that almost twice the amount spent on propane will be spent using to power generator. This shows that with propane gas as fuel source the living standard of the Nigerian populace will be improved on which in turns better the economy of the country through her Gross Domestic Products (GDP). The results translate to when approximately 80% of petrol is used to power a generator for a load, approximately 20% of propane will be used for the same types of load. Therefore, in terms of emission and money spent, propane is economical and environmental friendly.

CONCLUSIONS

From the development and evaluation of fuel used study, the following conclusions can be drawn:

- Propane generator has a 978 ppm of CO₂, 212 ppm of CO while petrol is 936 ppm and 383 ppm respectively, this indicate that propane is more environmental friendly than petrol.

- Powering 288 watts for 1 hr, propane gas is 0.6275213 times better than petrol.
- The cost of the kit is six thousand naira.

REFERENCES

1. Alamu, O.J. 2007. Optimal Operating Conditions for the Production of Biodiesel from Palm Kernel Oil. Unpublished Ph.D. Thesis: Mechanical Engineering Department. Ladoke Akintola University of Technology: Ogbomoso, Nigeria.
2. Bosch, B., Muljadi, E., Carlson, O., Pierik, J., Estanqueiro, A., Srensen, P., O'Malley, M., Mullane, A., Anaya-Lara, O., and Lemstrom, B., 2009. Dynamic Models of Electricity Generation for Power System Studies—European Energy Conference & Exhibition (EECE), London, U.K.
3. ECN. 2005. Energy Commission of Nigeria. Renewable Energy Master Plan; Executive Summary. Lagos Nigeria.
4. EIA. 2007. Energy Information Administration. World Proved Reserves of Oil & Natural Gas. Most Recent Estimates. www.eia.doe.gov. June 2007.
5. Ekpo, A.H. (2009). The Global Economic Crisis and the Crises in the Nigerian Economy, Presidential Address to the 50th Conference of the Nigerian Economic Society, September, Abuja-Nigeria.
6. Frank, M.W. (2004). Fluid Mechanics, Fifth Edition. McGraw Hill, New York.
7. Gaynor, J.K., (2002). “The Global Liquefied Natural Gas Market: Status and Outlook, Appendix, Energy Information Administration, Retrieved 12 May, 2013 Available on URL: <http://www.eia.doe.gov/oiaf/analysispaper/global/pdf/app-f.pdf>
8. Kevin, K. (2012). Snelling Made Discovery that Lit Flame on Propane Industry – www.lpgasmagazine.com.
9. Klempner, G and Kerszenbaum, I. (2004). Operation and maintenance of Large Turbo Generators. John Wiley & Sons, Inc.
10. Markita, R., (2008). Analysis of Electric Machinery, McGraw Hill Co. NY
<http://www.kane.co.uk/tech-tips-faqs/359-what-are-safe-levels-of-CO-and-CO2-in-rooms>.
11. Myrtle, B., (2012). Chapter 6, Gases Properties of Gases, Beach Chemistry.
12. Olugbenga, T. K., Jumah, A.A. and Phillips, D.A. (2013). The Current and Future Challenges of Electricity in Nigeria in the Face of Deregulation Process. African Journal of Engineering Research Vol.1(2), pp 33-39.
13. Oyem, I.L. (2013): Analysis of Nigeria Power Generation Sustainability through Natural Gas Supply. Journal of Innovative Research in Engineering and Science. 4(1) pp434-443.