

## Development of Laboratory-Scale Salt Bath Furnace

\*Ukoba Kingsley, Aigbogun, J.O; Alasoluyi J.O.; Oyelami, A.T (PhD); Idowu A.S.; Babatunde, G; and Olusunle, S.O.O (PhD)

Engineering Materials Development Institute, PMB 611, Akure, Ondo state, Nigeria

\* E-mail of the corresponding author: [ukobaking@yahoo.com](mailto:ukobaking@yahoo.com)

### Abstract

A salt bath furnace was developed using electrical heating as source of heat which can be used in tertiary institution laboratories as well as by small and medium scale enterprises (SMEs). The salt bath was designed and manufactured virtually using CAD/CAM procedures, after which the production and assembling was carried out. A Material selector software aided in the materials selection, where mild steel was selected as the material for the casing, while other materials for the construction were selected based on functions and properties of the materials, cost considerations and ease of fabrication into component parts. The performance of the furnace was evaluated and, it was observed that the salt bath furnace has relatively fast heating rate of 16.67<sup>0</sup>C/min when compared to conventional brands of salt bath and muffle furnaces that are available in the market. The furnace also has good heat retaining capacity and uniform heating rate.

**Keywords:** Salt bath furnace, Heating Rate, CAD/CAM, Small and Medium scale enterprises (SMEs)

### 1. INTRODUCTION

The salt bath furnace can be utilized for conventional heat-treatment processes and for various thermo-chemical heat-treatment processes such as: carburizing, nitriding, and cyaniding (Yutaka, 2000). It is equally useful for preheating, isothermal quenching, austempering just to mention a few. Apart from its versatile process usefulness, it also has the advantage of giving uniform heating of the material and controlled atmosphere (Reid, 2006). These advantages make the use of salt bath furnaces an indispensable facility in heat treatment operations. The relative high cost of furnaces in the market was one of the motivations for this work.

#### 1.1 Objective

The aim of this work is therefore to develop a salt bath furnace that is efficient and affordable so as to make available salt bath furnace that can be used to heat-treat with ease with high degree of safety with little maintenance.

#### 1.2 Previous works

Some work has been done in the area of salt bath furnace. Recent amongst them is Alaneme et al 2010 where the production and evaluation of a diesel fired furnace using diesel as its source of fuel for the heating, Ojiegbe, K. k. (2005) also worked on the design and construction of a Diesel- Fired Heat Treatment Furnace. Andrew Gascoigne, 2011 wrote extensively on how to build a home heat treatment furnace, He enumerated the various step of doing-it-yourself for heat treatment furnace from home. Andrew Gascoigne's work is mainly for a furnace that can be used at home. Ukoba et al (2012) also developed a low heat treatment furnace that can be used for heat treatment of ferrous metals, non-ferrous metals and their alloys for a temperature ranging between 850<sup>0</sup>C to 880<sup>0</sup>C. A salt bath furnace that will make use of heating element (electricity) as its source of heat was developed. It will be used by laboratory of tertiary institutions and for small and medium scale purposes.

### 2. METHODOLOGY

#### 2.1 Materials

The materials that were utilized for the fabrication of the furnace are: Outer casing is 5mm thick mild steel, middle casing is 3mm thick mild steel, inner or last casing is 5mm thick mild steel, refractories, temperature controller, thermocouple, switch, wire light indicators, salts, paint, black tape, thread tape, body filler, adhesives, plug, and mild steel test samples of predetermined chemical composition.

##### 2.1.1 Material Selection

###### Steel Sheet

The steel sheet selected is a mild steel of composition: 0.15%C, 0.45%Mn, 0.18%Si, 0.18%Si, 0.031%S,

0.001%P, 0.0005%Al, 0.0008%Ni and balance Fe. The composition was determined spectrometrically with the use of a spark spectrometric analyzer. It was selected for the fabrication of the bath casing with preference on Aluminum and stainless Steel because of its light weight, excellent formability, availability, and low cost.

Other components and parts selected for the design were influenced by cost, availability, efficiency and reliability.

**Quantity of Heat from Source:** The heat source is generated from the industrial heating element which takes a period of 1hour to attain its maximum loading capacity. This is supported by the Joule- Lenz's law.

$$E = I^2Rt \quad (1)$$

Where;

E=electrical energy

I=current flowing in the circuit

R=resistance to flow in the circuit

t= time- taken for maximum heating

But from Ohm's law;  $V = IR$

V is voltage across the circuit

$$\text{Hence; } E = \frac{V^2t}{R} \quad (2)$$

Given that;

V=240volts

R=1.85

t=3600secs

$$E = 112,320,287.6J \quad (3)$$

$$\text{But, rate of heat flow; } Q = \frac{E}{t} \quad (4)$$

Q=31.2kJ/s

### Design Assumptions and Constants

Convective coefficient of air ( $h_{\text{air}}$ ) = 500W/m<sup>2</sup>k

Door efficiency ( $\epsilon$ ) = 1(assumed)

Heating time (t) = 1hour

Resistance in the circuit (R) = 1.85

Thermal conductivity of the brick ( $K_b$ ) = 1.28W/mk (Mark's Handbook)

Voltage across the circuit (V) = 240volts

## 2.2 Design and Construction of the furnace

The salt bath furnace was designed with Computer Aided Design and Manufacturing (CAD/CAM) software as shown in figures 1 and 2 while the fabrication and assembly was done on the shop floor as shown in plate 1. The Final product was then tested and evaluated.

### 2.1.1 Design Principles

The molten salt bath furnace consists essentially of a furnace pot made of metal. This container holds molten salt in which the work pieces are immersed. The mode of heat transfer to the work piece is by convection through the liquid bath. The molten bath possesses high heat capacity which results in the work piece being heated up very quickly. The design philosophy was to fabricate a molten salt bath furnace that will work efficiently at an affordable cost of production. Thus the following design considerations were taken: Power consumption

(electricity) required to operate the furnace should be at a minimum; the component parts should be easily replaceable in case of damage or failure; and the design should be simple for easy construction and ease of operation; and safety of the operator must be guaranteed.

#### 2.1.1 Design conception and assumptions

According to the literature given by International Electric Equipment (IEE, 1994) regulations, basic standard parameter for the design and construction of a furnace comprises the following: the casing design, the insulating system, the electrotechnicals, and the safety/ controls system

#### **Furnace Pot**

The salt bath furnace was conceived to be used for the heat-treatment of laboratory-size components and parts: thus the following design dimensions were used for the construction of the furnace pot: Diameter = 600mm, Height = 500mm, Flange = 540mm, Flange thickness = 5mm.

#### **Casing design and construction**

The Salt bath furnace casing is the main housing of the furnace it was designed to have a cylindrical shape for simplicity of construction. The required dimension for the casing was cut and folded on a bending machine in order to form the cylindrical shape. Three development sheets of 5mm thick (Outer casing), 3mm thick (middle casing), and 5mm thick (Inner or last casing), were cut, rolled and welded to form the outer, middle and inner casing of the furnace with final diameter of 600mm, 550mm and 500mm respectively. After the welding operation has been carried out, welded joints were grinded to remove carbon chips. This was followed by the application of body filler on the casing and it was painted after air drying in order to give a smooth and good finishing.

#### *2.3 Constructing the furnace*

##### 2.3.1 Lining of the Furnace

The arrangement of the lining of the furnace is such that there is refractories lining at the bottom followed by fiber glass then inner refractories lining resulting to air gap for insulation. This is shown in figure 2.

##### 2.3.2 The furnace cover

The cover of the furnace is insulated with refractory with thermocouple incorporated to measure the temperature of the furnace bath.

##### 2.3.3 *The Salts used*

Two different salts were used for the austenitizing and austempering respectively. Potassium chloride, Sodium Chloride and Barium Chloride were mixed for the austenitizing salt for a temperature of 850°C to 900°C while Sodium Nitride and Potassium Nitrate were mixed for the austempering for a temperature of 250°C to 300°C

#### **Main Switch and Light Indicator:**

**Description:** The main switch and light indicator are also part of the electrotechnicals. The main switch controls the power source input as it allows electric power to flow into the circuit when switched-on and prevents the inflow when switched-off. The light indicator signals the furnace operator if electrical energy flows uninterrupted into the heating element. When the light is on, it signals continuity in the circuit but if the light is off, it signals discontinuity. They are well positioned on the furnace where the temperature is very minimal and fusing or damage is prevented during operation.

**Materials:** The electrical- carrying light/current are made of thermosetting materials so that they do not fuse or damage easily, and are placed on the outer casing.

##### 2.3.4 *Assembling*

The assembling of the salt bath furnace was carried out manually. After the successful completion of the construction processes, such as the furnace casing, which comprises of the casing and the charging door, introduction of the electrotechnicals namely; temperature controller, the main switch and the light indicator, and taking into consideration the required suitable engineering materials, all parts are assembled together as shown in Plate 1. The assembly is made possible with the use of arc welding, boring and screwing with the use of

appropriate tools. Electrical parts are also joined and insulated with tape to prevent shocks or discontinuity in the circuit.

### 2.3.3 Electrical Connections

Well insulated wires were used in other to prevent shocks and hazards.

### 2.4 Testing:

The photograph of the Salt bath furnace after installation is presented in Plate 1. The performance and working efficiency of the furnace was evaluated by determining the furnace heating rate, and ability to maintain constant temperature.

## 3. PERFORMANCE EVALUATION

The performance of the furnace was evaluated by using its functionality (Temperature Sensing and heating rate), aesthetics, maintainability, cost analysis, estimated life span as basis for assessing the efficiency of the furnace.

### 3.1 Functionality of the Furnace

*Effectiveness of Temperature Sensing:* The thermocouple tip is positioned in the salt bath one – third from the base and the salt at molten is convectional, so there is homogeneity of the temperature in the inner pot. The temperature controller is digital which makes the reading sensed to be accurate. There is also regular temperature check using an external probe to calibrate the temperature controller thereby guaranteeing effective temperature reading.

*Heating Rate:* The heating rate of the salt bath furnace was equally evaluated as it serves as a measure of the time taken to attain the desired temperature, and the duration of the treatment. The furnace was heated to 1000<sup>0</sup>C and a time of 60 minutes was taken to attain the temperature. This gives a heating rate of 1000<sup>0</sup>C/60mins = 16.67<sup>0</sup>C/min (0.1667<sup>0</sup>C/s). This heating rate is quite high in comparison to 7.08<sup>0</sup>C/ min of the 30/60 capacity salt bath furnace designed in Germany by Degussa (2006) and that of 12.5<sup>0</sup>C/min by Alaneme et al (2010). Thus the Salt bath furnace designed can be said to be very efficient in service in comparison to similar standard furnaces from outside the country. Equally critical in the performance evaluation is its sensitivity and ability to maintain a constant temperature during isothermal treatments. The furnace lining also shows its effectiveness by preventing heat loss from the heating chamber to the furnace surroundings.

**Maximum Attainable Temperature:** With the aid of optical pyrometer, the initial maximum temperature attained was 1000<sup>0</sup>C.

**Temperature Fluctuations:** The overall temperature of the furnace heating environment varied between 950<sup>0</sup>C and 1000<sup>0</sup>C, whereas the temperature at the casing varies between 23<sup>0</sup>C and 27<sup>0</sup>C. Measurements were repeated five times as a standard with scientific practical equipment testing.

**Time to Attain Maximum Temperature:** Although, theoretical expectation for achieving the temperature of 1000<sup>0</sup>C was supposed to be 60minutes, it actually takes about 70minutes to attain the temperature of 1000<sup>0</sup>C.

**Possible Heat Treatment Applications** Since the maximum attainable temperature is 1000<sup>0</sup>C. Comparing this with some certain heat treatment operations and their relative process temperature, it will be possible to carry out the following heat treatment processes: preheating, isothermal quenching, austempering, austenitizing, etc.

**Operation Procedure:** The operation procedures determine the process to be done on the furnace. But basically, it involves placing the material to be heated in the furnace after which the door of the furnace should be closed. The furnace is thereafter switched on from the mains; turn the knob of the temperature controller to the desired heat treatment temperature. After attaining the temperature and holding for a reasonable time, switch off the furnace before removing the sample from the furnace.

## 4. CONCLUSION

The Furnace was specifically designed for controlled heating of element/material of temperature range of 950<sup>0</sup>C but it can equally be adapted for use in other heating operations of same temperature range. The result obtained makes it possible for usage in several applications and processes with maximum safety and precaution in place.

## 5. ACKNOWLEDGEMENT

Authors wish to acknowledge works that were used and subsequently cited. Also, we appreciate the effort of Mr. R.A. Bello, Mr. S.A. Lawrence, Mr. A.O. Akinola, Mr. S. O. Ademoyejo, Mr. M.B. Balogun, Mr. O.S. Olaseinde, Mr. O.I. Olorundare, Mr. I.A. Oyerinde, Mr. S.O. Adigun, Mr. O.A. Ojo, Mr. A.E. George, Mr. A. Yusuf and Mr. A. Adedeji everyone that contributed to this work too numerous to mention.

**References**

Alaneme, K. K. and Olarenwaju, S. O. (2010). Design of a Diesel fired Heat-treatment Furnace, Journal of Minerals, Materials Characterization and Engineering, 9, 581 - 591.

Aluko, F.O. (2004). “The Effect of Heat Treatment on the Corrosion Properties of Grey Cast Iron on Paper Making Industries” NJEM, vol. 5, No 1. Pp 31 – 33.

Degussa (2006). Degussa Fuel-Fired Furnace Handbook, Degussa Salt Bath Company, Germany.

Gascoign,A. (2011). A home built heat treatment furnace. [Online] Available: <http://www.bbuk.net> (2011).

International Electric Equipment (IEE) Regulation (1994): European Economic Area, Oporto.

Mark’s Mechanical Engineering Handbook (1961): McGraw-Hill Book Company Incorporation. New York, USA. Pp 7-82.

Ojiegbe, K. k. (2005): The Design and Construction of a Diesel- Fired Heat Treatment Furnace. A Final Year Project, Federal University of Technology, Akure. Pp 40-52, 55-63.

Reid, B. (2006). Pack Thermal Industrial Heating; Solution to Salt Bath Furnaces, Ontario, Canada.

Ukoba, O. K; Anamu, U. S; Idowu, A. S; Oyegunwa, A. O; Adgidzi, D, Ricketts, R; Olusunle, S.O.O (2012). Development of low heat treatment furnace. International Journal of Applied Science and Technology Vol. 2 No. 7; 188 – 194.

Yutaka, (2000). Salt Bath Heat Treatment, Trends and prospects of heat treatment in 21st century. 3rd Edition, 140-147.

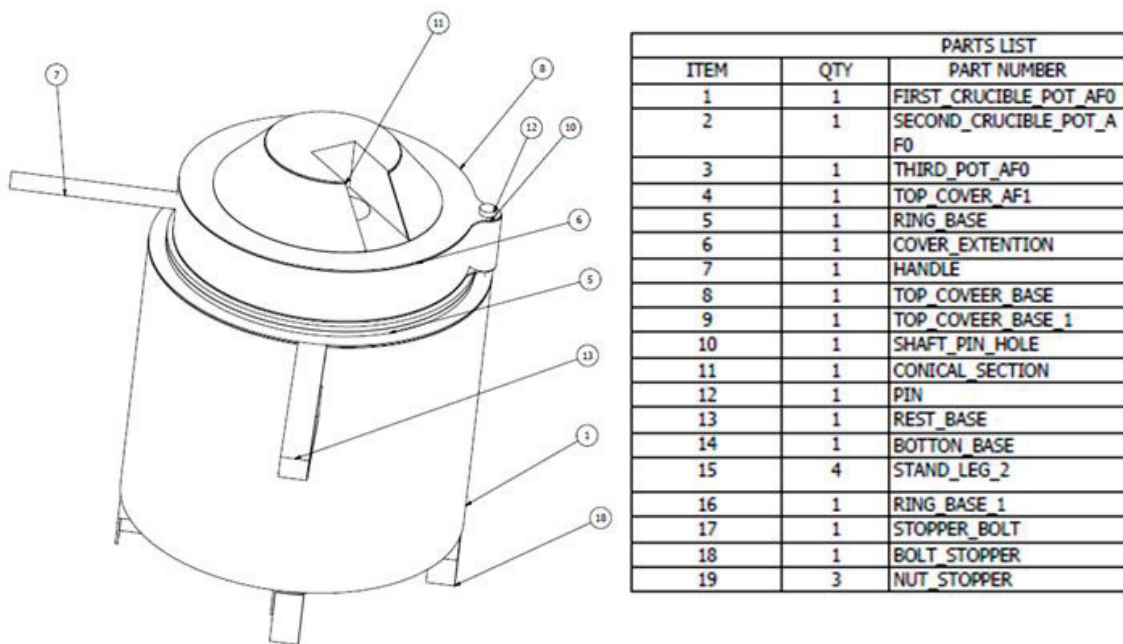

Figure 1. Isometric View of the Salt Bath Furnace



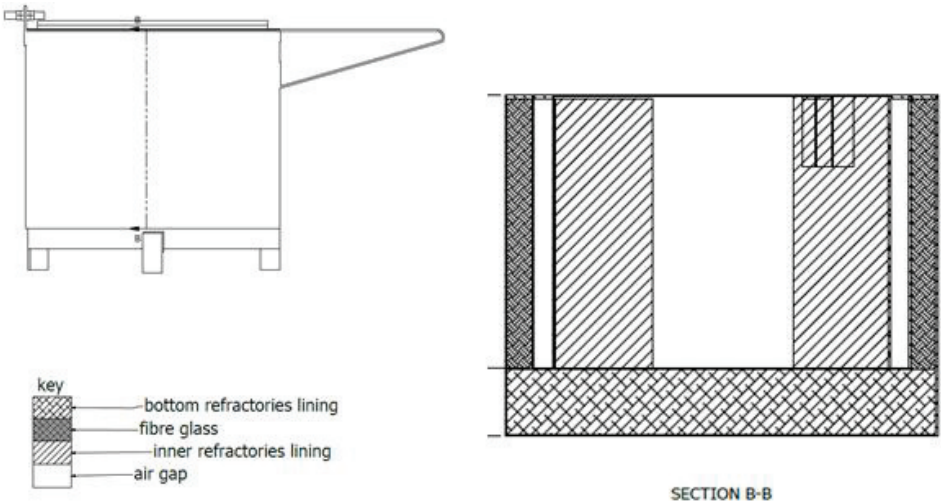

Figure 2. furnace showing the Lining



Plate 1: The painted salt bath furnace

The IISTE is a pioneer in the Open-Access hosting service and academic event management. The aim of the firm is Accelerating Global Knowledge Sharing.

More information about the firm can be found on the homepage:  
<http://www.iiste.org>

## CALL FOR JOURNAL PAPERS

There are more than 30 peer-reviewed academic journals hosted under the hosting platform.

**Prospective authors of journals can find the submission instruction on the following page:** <http://www.iiste.org/journals/> All the journals articles are available online to the readers all over the world without financial, legal, or technical barriers other than those inseparable from gaining access to the internet itself. Paper version of the journals is also available upon request of readers and authors.

## MORE RESOURCES

Book publication information: <http://www.iiste.org/book/>

## IISTE Knowledge Sharing Partners

EBSCO, Index Copernicus, Ulrich's Periodicals Directory, JournalTOCS, PKP Open Archives Harvester, Bielefeld Academic Search Engine, Elektronische Zeitschriftenbibliothek EZB, Open J-Gate, OCLC WorldCat, Universe Digital Library, NewJour, Google Scholar

