

Induction Machine Stator Inter-Turn Short Circuit Fault Detection using Discrete Wavelet Transform

Syed Kamruddin Ahamed^{1*}, Arghya Sarkar², Madhuchhanda Mitra³ and Samarjit Sengupta⁴

1. Govt.College of Engineering & Textile Technology, Serampore, Hooghly, W.B., PIN- 712201

2. MCKV institute of Engineering Howrah, PIN -711204

3,4. Dept. of Applied Physics, University of Calcutta

* E-mail of the corresponding author: syedahamed.ahamed9@gmail.com

Abstract

A novel technique for the detection of stator inter-turn short circuit fault of the induction motor is presented. At first, the discrete wavelet transform (DWT) is performed on the windowed steady state stator currents to obtain the detailed coefficients at higher wavelet level. It has been observed that the faulty motor produces higher statistical parameters of the reconstructed details- RMS and Power Detailed Energy (PDE) than those values for the healthy one. Illustrative laboratory test results confirm the validity and accurate performance of the proposed method.

Keywords: inter-turn short, induction motor, Discrete wavelet transform, power detail energy, RMS value.

1. Introduction

Induction motor is the main prime mover in most of the modern day industries and any failure in it becomes cost effective. To prevent downtime losses and safety of the operator, fault is to be detected and monitored at its childhood stage to initiate remedial action before it becomes severe.

According to the survey made by IAS Motor Reliability Working Group (1985), 35-40% of induction motor failures are usually related to insulation failures of the stator. Many works have indicated that most of the stator winding failures start as undetected turn to turn faults in a single phase due to destruction of insulation which finally grow and terminate in major faults. This type of fault is known as stator turn fault [2], described by Sottile and Kohler (1993). The various causes of stator failures have been presented in their works by Bonnet et.al.(1992) [3] and are available from the source: www.indiaelectricmarket.com. [online]. From the investigation, it has been revealed that most of the faults occur due to the effects of thermal, electrical, mechanical and environmental stresses. As a rule of thumb for every 10⁰C rise of temperature beyond its normal limit, the life of insulation gets halved due to thermal ageing [5] as Lipo (2004) has illustrated in his research article.

Several diagnostic techniques have been proposed in the literature for stator winding faults like partial discharge testing by Stone et.al.[1995], vibration monitoring by Leonard et.al. (1986), analysis of axial flux by Penman et.al.(1994), acoustic noise monitoring by Lee et.al. (1994), temperature monitoring of the winding [10], measurement of induced voltage along the shaft [10] and gas analysis due to degradation of insulation that passes into cooling air circuit etc [10] by Tavner et.al.(1986), measurement of Air gap torque by Hsu(1995), Current monitoring by Benbouzid (2000). Many of the techniques needs delicate sensors which are cost effective and when the motors are operating in hostile atmosphere, the installation and maintenance of these sensors are difficult. Researchers focus their attentions on motor current signature analysis (MCSA) i.e. current monitoring due to its easy availability and non-invasive nature (as almost all the motors in the industries incorporated with current measuring arrangements). Thomson and Fenger (2001), Joskimovic and Penman (2000) have used MCSA through FFT analysis to search for characteristic (spatial) harmonics in the stator current to detect fault in the winding. However, in this approach similar types of harmonics are observed due to eccentricity related faults. Apart from this, supply unbalance and constructional imperfection produce similar effects as Nandi et.al. (2005) reported in their paper. Oveido et.al.(2011) has utilized Negative sequence current and Tallam et.al. (2003) used negative sequence voltage [16],[17] in their works for diagnosis of stator shorted turns faults. But these two parameters cannot be taken alone as reliable indicators because they are not immune to unbalance of supply and inherent asymmetry of the motor as described by Villada et. al. (2010) in their research article. Q.Wu and S. Nandi (2008) have explored in their works that positive and negative sequence third harmonic components are good identifiers of stator inter-turn fault at its incipient stage. Cardoso et. al. have utilized Park's vector approach

(1999) in their research. O.A. Mohammed et. al. (2006) and Cusido et. al. (2008) have applied Wavelet transform, specially discrete Wavelet Transform (DWT) for diagnosis of motor fault as illustrated in their research articles.

The present paper proposed a novel approach for diagnosis of stator inter-turn short circuit fault of the induction motor. The proposed algorithm relies on efficient application of the Discrete Wavelet Transform (DWT) of windowed signals. Windowing is used to shape the portion of measured data required for analysis to minimize the edge effects that result in spectral leakage in the spectrum. It improves the frequency resolution and amplitude accuracy to detect exact frequency peaks. Fault detection algorithm in real time is discussed and experimental results are provided. Laboratory test results confirmed that high accuracy can be obtained using the proposed scheme.

2. DISCRETE WAVELET TRANSFORM

The DWT decomposes a given signal into its constituent wavelet sub-bands or levels (scales) with different time and frequency resolution. Each of the signal scale represents that part of the original signal occurring at that particular time and in that particular frequency band. These individual scales tend to be of uniform width with respect to the log of their frequencies. Fig. 1 represents the pyramidal algorithm with QMF-bank for multiresolution decomposition up to second level as described in his book by Mallat (1998).

The scaling coefficients (approximation) at j^{th} level and k^{th} time can be computed by taking the inner products of the function $x(t)$ with the scaling basis $\phi_{j,k}(t)$ as follows

$$a_{j,k} = \langle x(t), \phi_{j,k}(t) \rangle = \int_{-\infty}^{\infty} x(t) \phi_{j,k}(t) dt \quad (1)$$

The wavelet coefficients (details) at j^{th} level and k^{th} time become

$$d_{j,k} = \langle x(t), \psi_{j,k}(t) \rangle = \int_{-\infty}^{\infty} x(t) \psi_{j,k}(t) dt \quad (2)$$

where $\psi_{j,k}(t)$ is the wavelet basis.

The scale function and wavelet function are determined by the selection of a particular mother wavelet and the following equations:

$$\phi_{j,k}(t) = 2^{j/2} \phi(2^j t - k) \quad (3)$$

$$\psi_{j,k}(t) = 2^{j/2} \psi(2^j t - k) \quad (4)$$

The corresponding relationships of scaling function and wavelet function between two consecutive resolution levels j and $(j+1)$ are defined in (5) and (6) using Mallat algorithm as described by Mallat (1998).

$$a_{j,k} = \sum_n h_w(n-2k) a_{j+1,n} \quad (5)$$

$$d_{j,k} = \sum_n g_w(n-2k) a_{j+1,n} \quad (6)$$

where sequences $h_w(n)$, $n \in Z$ and $g_w(n)$, $n \in Z$ are quadrature mirror filter (QMF) bank. The sequence $h_w(n)$ is known as low-pass filter, while $g_w(n)$ is known as high-pass filter. At each scale, the number of the DWT coefficients of the resulting signals is half that of the decomposed signal.

3. Proposed Scheme

This paper presents a novel technique for identification of Induction motor stator inter-turn short circuit fault at no-load condition and single mass load. The algorithm steps are summarised below:

Step 1: Use suitable window function to obtain specific size data vector from stator current of the Induction Motor. Window function is utilized to reduce the effect of transients.

Step 2: Perform Discrete Wavelet Transform in such a fashion that the detailed coefficients at higher levels correspond to narrow band frequencies below 50 Hz.

Step 3: Compute statistical parameters – RMS values and Power Detailed Energy (PDE) of higher level wavelet coefficients. PDE is defined as

$$PDE = \sum_1^N (d_j \times d_j) \quad (7)$$

where level of decomposition j , containing N number of samples .

Step 4: Compare the statistical parameters with set value to obtain the information about the health of the Induction Motor.

Step 5: Go to Step 1.

This paper selects Hamming window of length 10240 (5 secs. duration) samples. Then Discrete Wavelet Transform was performed using db4 mother wavelet. The spectral frequency bands at different decomposition level are presented in Table I for the sampling frequency 2048samples/secs.

4. Experimental Setup

Experiment was carried out on a test-rig built by Spectra Quest, USA, having a high speed data acquisition system (OROS OR35, 8 channels, 100 mbps). One induction motor with 3ph, 1HP, 415V, 50Hz, 1460rpm incorporated with provisions for shorting from outside tappings . The same motor can be used as healthy and shorting turns (5% and 10%) in stator winding as faulty .The motors were run by direct-on-line supply at 330V, 50Hz. Current signature was captured using Hall Probe (LEM PR30 ACV 600V CATIII 30Ampac / 3Vac). The experimental set up and its schematic block diagram are shown in Fig. 2 and Fig. 3 respectively.

5. Result Analysis

Wavelet Transform using db4 were performed on the windowed (Hamming window) steady state signals (Sample size of duration of 5secs) at no-load and single mass load. Reconstructed details for the motor with the healthy and faulty conditions corresponding to 6th, 7th and 8th levels i.e. spectral bands below 50 Hz shown in Fig. 4, Fig. 5, Fig. 6 at no-load and Fig. 7, Fig. 8, Fig. 9 at single mass load were analysed.

It is observed from the Table II that at no- load, RMS values and PDE at all the three levels indicate higher values for the faulty motor than those for healthy one. Table IV indicates that at no- load, the %tage variations in the values of RMS which are very high for the motor under faulty condition with respect to the healthy motor are 110.34,100, 81.98 for 5% stator turn short and for 10% stator turn short, the %tage variations are 265.52, 243.9 and 484.41 respectively at 6th, 7th and 8th levels. Considering the values of PDE, these %tage variations are 337.10, 3872.0, 238.46 for 5% stator turn short and for 10% stator turn short, these the %tage variations are 1212.78, 11819.19, 3253.84 respectively at 6th, 7th and 8th levels. From the observations, it is obvious that at no-load, the parameters considered sharply increases under faulty conditions with respect to the motor under healthy condition.

The results in Table III indicates that at single mass load, the values of RMS are very high for the motor under faulty condition with respect to the healthy motor. From Table V, it is seen that the the %tage variations in the values of RMS which are also very high for the motor under faulty condition with respect to the healthy motor are 40.79, 39.28, 302.48 for 5% stator turn short and these variations are 43.42, 84.82, 417.24 for 10% stator turn short respectively at 6th, 7th and 8th levels, specially 8th level indicates much higher variation. On the other side, the %tage variations in the values of PDE are 95.24, 39.06, 1575 .00 for 5% stator turn short and for 10% stator turn short, these variations are 258.86, 147.11, 2542.85 respectively at 6th, 7th and 8th levels. From the analysis, it is observed that at single mass load, the parameters considered shows sharper increase for motor under faulty conditions with respect to the motor under healthy condition. It is observed from the Table IV that at single mass load, the values of PDE and RMS for 5% stator turn short and 10 % stator turn short indicate higher values at all the three levels and specially at 8th level, the variations are much more higher.

From the above discussion, it can be inferred that these variations in the values of RMS and PDE of the reconstructed detailed coefficients can be efficiently used for detection of stator turn short both at no-load and load condition.

6. Conclusion

In this paper, a novel monitoring system has been described to detect the stator inter-turn short circuit fault of the Induction Motor. The spectral leakage is minimised and the effects of transients are reduced due to application of window function. The investigation reveals that the proposed method can successfully be employed for on-line monitoring of stator winding turn short both at no-load and load. The developed scheme is fast, highly reliable and low cost, ideally suited for industries. The method may also be applied for other fault analysis.

References

- IAS Motor Reliability Working Group (1985), "Reports of large motor reliability survey industrial and Commercial installation, part I," *IEEE Transactions on Industry Applications*, vol.1A21, pp.853-864, July/Aug.,1985.
- Sottile, J. and Kohler, J. L., (1993), "An on-line method to detect incipient failure of turn insulation in random-wound motors," *IEEE Transactions on Energy Conversion*, vol.8, no.4, PP.762-768, December, 1993.
- Bonnett, A. H. and Soukup, G. C. (1992), "Cause and Analysis of Stator and Rotor Failures in Three-Phase Squirrel-Cage Induction Motors," *IEEE Trans. Ind. Appl.*, vol. 28, no.4, pp.921-937, 1992.
- Lipo, T.A. (2004), "Introduction of A C machine design", Wisconsin Power Electronics Research Centre, 2nd edition.
- Induction Motors (LV/HV) Failures and its Prevention Guidelines Available[Online] :
www.indiaelectricmarket.com.
- Stone, G. C. and Sedding, H. G. (1995), "In-service evaluation of motor and generator stator windings using partial discharge tests," *IEEE Trans. Ind. Applicat.*, vol. 31, pp. 299-303, 1995.
- Leonard, R. A. and Thomson, W. T. (1986), "Vibration and stray flux monitoring for unbalanced supply and inter-turn winding fault diagnosis in induction motors," *Br. J. Non-Destr. Test.*, pp. 211-215, July, 1986.
- Penman, J., Sedding, H. G., Lloyd, B. A. and Fink, W. T. (1994), "Detection and location of Inter turn short circuits in the stator windings of operating motors," *IEEE Trans. Energy Conversion*, vol. 9, pp. 652-658, Dec. 1994.
- Lee, Y.-S., Nelson, J. K., Scarton, H. A., Teng, D. and Ghannad, S. A., "An acoustic diagnostic techniques for use with electric machine insulation," *IEEE Trans. Dielectr. Electr. Insul.*, vol. 1, no. 6, pp. 1186-1193, Dec. 1994.
- Tavner, P. J., Gaydon, B. G. and Ward, D. M. (1986), "Monitoring generators and large motors", *Proc. Inst. Elect. Eng. B*, vol. 133, no. 3, pp. 169-180, May 1986.
- Hsu, J. S. (1995), "Monitoring of defects in induction motors through air-gap torque observation," *IEEE Trans. Ind. Applicat.*, vol. 31, no.5, pp. 1016-1021, Sept./Oct. 1995.
- Benbouzid, Mohamed El Hachemi (2000), "A Review of Induction Motors Signature Analysis as a Medium for Faults Detection", *IEEE Transaction on Industrial Electronics*, vol. 47, no. 5, pp. 984-993, October, 2000.
- Thomson, W.T., Fenger, M. (2001), "Current signature analysis to detect induction motor faults," *IEEE Ind. Appl. Magazine*, vol.7, no.4, pp.26-34, July/August 2001.
- Joksimovic, G. M. and Penman, J. (2000), "The detection of inter turn short circuits in the stator windings of operating motors," *IEEE Transactions on Industrial Electronics*, vol.47, no.5, October, pp.1078-1084, 2000.
- Nandi, S., Toliyat, H. A., Li, X. (2005), "Condition Monitoring and Fault Diagnosis of Electrical Motors— A Review", *IEEE Transactions on Energy Conversions*, vol.20, no.4, December, 2005.
- Oviedo, S., Quiroga, J. and Borrás, C. (2011), "Motor Current Signature Analysis and Negative Sequence Current based Stator Winding short Fault Detection in an Induction Motor", *Dyna*, 170.
- Tallam, R.M., Habetler, T. G., Harley, R.G. (2003), "Stator winding Turn- fault detection for closed-loop induction motor drive," *IEEE Transactions Industry Applications*, vol. 39, no. 3, pp. 720-724, 2003.
- Villada, F., Cadavid, D.R., Aedo, J.E., Benavides, B.A., Velilla, E. (2010), "The negative impedance as fault indicator in induction motors", *Rev. Fac. Ing. Univ. Antioquia*, no.52, pp.226-232, Marzo, 2010.
- Wu, Q. and Nandi, S. (2008), "Fast Single-turn Sensitive Stator – Fault Detection of Induction Machines Based Positive and Negative Sequence Third Currents", 978-1-4244-2279-1/08, *IEEE*.
- Cardoso, A. J. M., Cruz, S. M. A. and Fonseca, D. S. B. (1999), "Inter-turn stator winding fault diagnosis in three-phase induction motors, by Park's Vector Approach," *IEEE Trans. Energy Conversion*, vol. 14, pp. 595-

598, Sept. 1999.

Mohammed, O.A. Abed, N.Y., Ganu, S. (2006) "Modeling and Characterization of Induction Motor Internal Faults using Finite Element and Discrete Wavelet Transform", *IEEE Transactions on Magnetics*, vol.42, no.10, October 2006.

Cusido, J. , Romeral, L., Ortega, J. A. , Rosero, J. A., (2008), "Fault Detection in Induction Machines Using Power Spectral Density in Wavelet Decomposition", *IEEE Transaction on Industrial Electronics* vol .55 , no.2 . February, 2008.

Mallat , S.(1998) : 'A wavelet tour of signal processing', *Academic Press*, San Diego, CA, 1998, 2nd edn.

Table I
 SPECTRAL FREQUENCY BANDS AT
 DECOMPOSITION LEVELS

Decomposition Details	Frequency Bands(Hz)
Detail Level 1	512 - 1024
Detail Level 2	256 - 512
Detail Level 3	128 - 256
Detail Level 4	64 - 128
Detail Level 5	32 - 64
Detail Level 6	16 - 32
Detail Level 7	8 - 16
Detail Level 8	4 - 8

Table II
 THE RMS VALUES AND PDE OF DETAILED COEFFICIENTS
 FOR THE FAULTY AND HEALTHY MOTORS AT NO LOAD

Wavelet Level	Motor Condition	Parameters	
		RMS	PDE
6	Healthy	0.0029	0.0876
	Faulty 5% shorted turn	0.0061	0.3829
	Faulty 10% shorted turn	0.0106	1.1500
7	Healthy	0.0041	0.0172
	Faulty 5% shorted turn	0.0082	0.6832
	Faulty 10% shorted turn	0.0141	2.0501
8	Healthy	3.5946×10^{-4}	0.0013
	Faulty 5% shorted turn	6.5415×10^{-4}	0.0044
	Faulty 10% shorted turn	0.0021	0.0436

Table III

THE RMS VALUES AND PDE OF DETAILED COEFFICIENTS FOR THE FAULTY AND HEALTHY MOTOR AT SINGLE MASS LOAD

Wavelet Level	Motor Condition	Parameters	
		RMS	PDE
6	Healthy	0.0076	0.5990
	Faulty 5% shorted turn	0.0107	1.1695
	Faulty 10% shorted turn	0.0145	2.1496
7	Healthy	0.0112	1.7823
	Faulty 5% shorted turn	0.0156	2.4785
	Faulty 10% shorted turn	0.0207	4.4042
8	Healthy	0.000522	0.0028
	Faulty 5% shorted turn	0.0021	0.0469
	Faulty 10% shorted turn	0.0027	0.0740

Table IV

VARIATION OF PARAMETERS OF THE FAULTY MOTOR W.R.T. HEALTHY MOTOR AT NO-LOAD

Wavelet Level	Motor Condition	%tage variation of Parameters	
		RMS	PDE
6	Faulty 5% shorted turn	110.34	337.10
	Faulty 10% shorted turn	265.52	1212.78
7	Faulty 5% shorted turn	100	3872.0
	Faulty 10% shorted turn	243.9	11819.19
8	Faulty 5% shorted turn	81.98	238.46
	Faulty 10% shorted turn	484.21	3253.84

Table V

VARIATION OF THE PARAMETERS OF FAULTY MOTOR W.R.T. THE HEALTHY MOTOR AT SINGLE MASS LOAD

Wavelet Level	Motor Condition	%tage variation of Parameters	
		RMS	PDE
6	Faulty 5% shorted turn	40.79	95.24
	Faulty 10% shorted turn	43.42	258.86
7	Faulty 5% shorted turn	39.28	39.06
	Faulty 10% shorted turn	84.82	147.11
8	Faulty 5% shorted turn	302.49	1575.00
	Faulty 10% shorted turn	417.24	2542.85

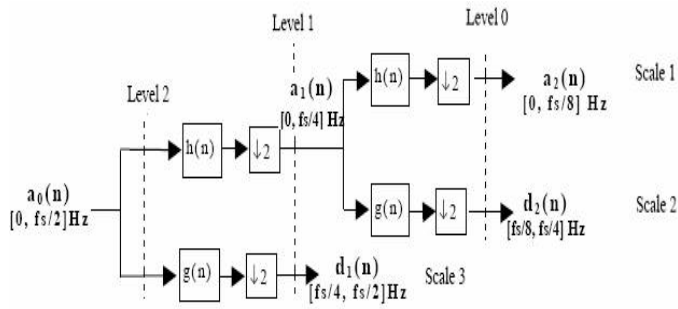

Fig.1. Pyrimidal algorithm with QMF bank.

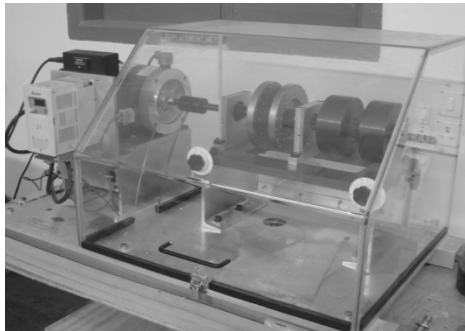

Fig. 2 Experimental setup.

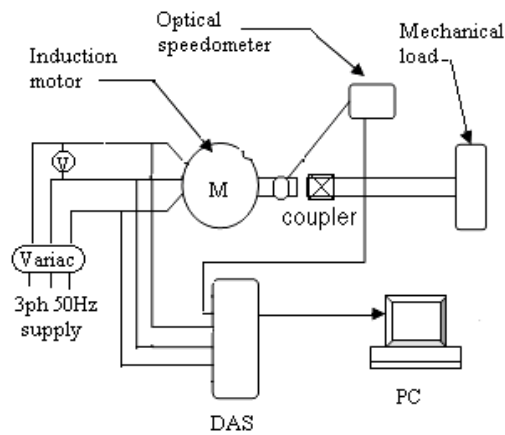

Fig. 3 Schematic block diagram of the experiment

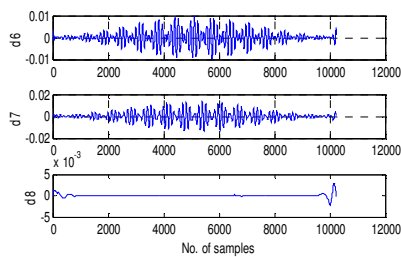

Fig. 4 Detail Co-efficient at 6th, 7th, 8th level at no-load (Healthy Condition)

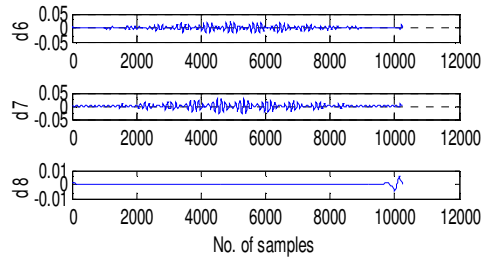

Fig. 5 Detail Co-efficient at 6th, 7th, 8th level at no-load (faulty Condition, 5% turn short)

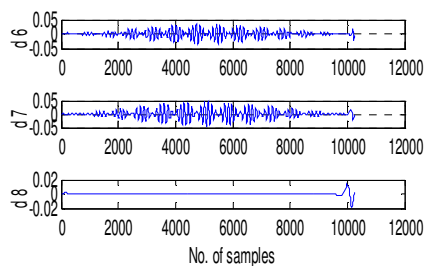

Fig. 6 Detail Co-efficient at 6th,7th,8th level at no-load (faulty Condition, 10% turn short)

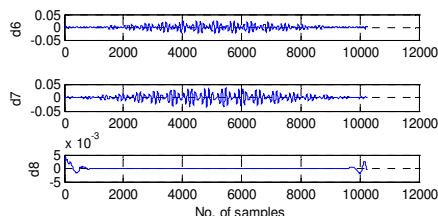

Fig. 7 Detail Co-efficient at 6th,7th,8th level at single mass load (Healthy condition)

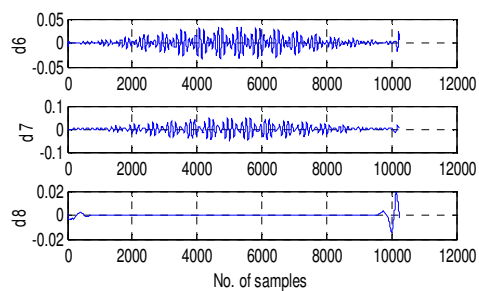

Fig. 8 Detail Co-efficient at 6th,7th,8th level at single mass load (faulty Condition, 5% turn short)

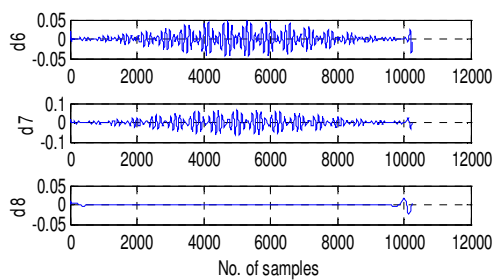

Fig. 9 Detail Co-efficient at 6th,7th,8th level at single mass load (faulty Condition, 10% turn short)