

# Shunt Active Power Filters Based On Diode Clamped Multilevel Inverter and Hysteresis Band Current Controller

1. PROF. DR. EMİN TACER, Department of Electrical and Electronic Engineering, Bahçeşehir University, Istanbul: Turkey
2. Akram Qashou, Department of Electrical and Electronic Engineering, Bahçeşehir University, Istanbul: Turkey  
Phone: +905314231082 and email: akram11\_qashou@hotmail.com
3. Nezihe yildiran, Department of Electrical and Electronic Engineering, Bahçeşehir University, Istanbul: Turkey

## Abstract

This work focused to design and implementing the three phase shunt Active Power Filter (SAPF) based in instantaneous reactive power theory which we used to generate the reference current and measure the power and reactive power and power factor and using Hysteresis Band Current Controller to obtain the gating signals for 11-steps diode clamped multilevel inverter (DCMLI). The proposed system represent two inverter Shunt Active filters is less total harmonic distortion (THD) and reduced semiconductor ratings compared with conventional inverter. The current drawn by the non-linear load and improve the source side power factor by compensate the reactive power. Also, the shunt Active Power Filter (SAPF) system response has been tested under steady state and transient conditions for real time current compensation harmonics. A study of its performance through simulation results will be investigated through MATLAB Simulink.

**Keywords:** Shunt Active power filter (SHAPF), diode clamped Multilevel Inverter (DCMLI), Hysteresis band controller.

## 1.1 Introduction

Most researchers studied shunt active power filters (APF) based on conventional two-level inverters with conventional controllers requiring a complex and a complicated mathematical model. In order to overcome this problem a hysteresis band controller based diode clamped multilevel inverter is used and extended to an 11- Step two inverters shunt active power filter.

## 1.2 Objectives

(a)-Two inverter Shunt active power filter will be used in this thesis to decrease harmonics in current wave and compensate reactive power of non-linear loads. A control system based on hysteresis band controller with Shunt Active Power Filter (SAPF) is proposed to study the system results and performance.

(b)-Three phase 11- Step Diode Clamped Multi-Level Inverter (DCMLI) proposed as a voltage source inverter instead of other inverters because specification of this type of lowest Total Harmonic Distortion (THD) and 11- Step according to the cost condition. [Harmonics current generation will be used by Diode Clamped Multi-Level Inverter (DCMLI) with the same magnitude of the source current harmonic but in opposite phase]. The DCMLI output will be connected at the point of common coupling of the system in order to avoid or cancel the current source harmonics.

(c)-Instantaneous reactive power theory based on proposed system, it will be employed to obtained the reference current of the DCMLI, the theory based on instantaneous values in three-phase power systems with or without neutral wire, and is valid for steady-state or transitory operations, in this theory instantaneous active current ( $i_p$ ) and instantaneous reactive current ( $i_q$ ) of three phase system are calculated based on Clark transformation which applied to the voltage and current vectors.

(d)-Hysteresis band controller will be used to optimize the switching pattern of diode clump inverter to compensate harmonic and reactive load currents.

(e)-Analyze the obtained results and compare it with other published results.

## 1.3 Problem Statement

The operation of non-linear loads in power system and applications almost creates harmonics currents and harmonics voltages especially in industrial systems. Therefore, the harmonic current and voltage exist at the same frequency where inductive and capacitive of industrial power system are equal, this situation reflected to the harmonic current and voltages and raise it and become much greater.

## 1.4 Literature Review

The power quality problem was as old as electrical system, but the interest in these problems starts from thirty years only. However, the use of active power filters has started only in the last twenty years. There are some of researches in this field in the last two decades are summarized as follows:

A distributed active filter system (DAFS) was discussed by (Po-Tai Cheng and Zhung-Lin Lee.2004), to alleviate power systems harmonic distribution. Multiple active filter units of the DAFS are proposed to install on the same location or different locations within the power system. In order to reduce the power lines voltage harmonic distortion, the active filter units of the proposed DAFS cooperate without any communication among them. They reduce voltage harmonics by work like a harmonic conductance. A controller of each unit is programmed by droop relationship between the volt-ampere of the active filter unit and the harmonic conductance so multiple active filter units can share the workload of harmonic filtering. The volt-ampere rating of the active filter unit decides the slope of the relation in order to evenly distribute the workload according to the each unit rated capacity. The distributed deployment of active filter units also shows that they can effectively improve the power lines voltage THDs more than installing active filter in the radial system terminals.

The converter absorbed a current rich in harmonics. This would disrupt the network and the consumers joined at the same node will influences. Several techniques used including active filtering and/or passive, to minimize the harmonics of side network. (M. T. Benchouia, M.E.H. Benbouzid, A.Golea, S.E.Zouzou, 2007), have discussed these techniques. Adaptive controller Referenced by The Fuzzy Model is used to minimize the converter harmonics of the side network, including the DC-link voltage and power factor control. The result shows the line current wave is approximately sinusoidal. They found that, the system has adequate dynamic response to load variation according to the rapid change of the line current results. Also they found that any external disturbance has not affected the reactive power. Also the study ends with the result that the increasing or decreasing of step load torque determines the sign of the Input real power peaks.

Harmonic current-source load generates the harmonics and by using both of the shunt passive filter and shunt active filter this harmonics can be compensated. Passive filter is not recommended to use because the system impedance strongly determined the performance of passive filter and it may cause resonance problem, and so, the active filter is more attractive.

If the harmonic of the voltage source load compensated by using shunt passive filters or shunt active filters, an over current problems may occurs due to the amplification of the load current. The active filter capacity may be the same or larger than that of the load. Hence, it is neither practical nor economical to use shunt active filter to compensate harmonic voltage source. The power factor improvement is the determinant of the capacity of passive filter; it may be overloaded in the harmonic voltage source application. When applying active filter with harmonic voltage source load, a series reactor must be placed on the load side.

Another research discuss the design and simulation of Harmonic and power factor compensation of multiple non-linear loads of a single phase shunt active power filter by (Z.F. Hussien, N. Atan, I.Z Abidin,2003). Whereas the active filter is based on a full bridge single phase inverter. The system was modeled in Mat lab Simulink to consist of an AC controller as nonlinear loads connected to active filter to enhance the harmonic of the current injected by the load, and an uncontrolled rectifier.

The differences between the proposed model and other models are as follows:

- Topology is a Shunt Active Power Filter, current source for Ibrahim.A. Altawil, (2011), while it is a comparison between two techniques to reduce THD multilevel voltage source inverter using cascaded inverters with separated DC sources for Siriroj Sirisukprasert , (1999), and it is a shunt hybrid active power filter system, for current source inverter based induction furnace(CSI-IF) for Adnan Tan, (2011), but it is a Two inverter Shunt Active Power Filter Current source for the proposed model
- Load is a nonlinear load with inductive load for Ibrahim.A. Altawil, (2011), while it is in each phase, a resistor and inductor are connected in series for Siriroj Sirisukprasert , (1999), and it is a Nonlinear (CSI-IF) for Adnan Tan, (2011), but it is a nonlinear load (rectifier load bridge, inductive and DC motor) for the proposed model.
- Simulation model is a three phase nine steps diode clamped multi level inverter Ibrahim.A. Altawil, (2011), while it is three phase seven steps Multilevel voltage source inverter using cascaded inverters with separated DC sources using triangular-carrier method for Siriroj Sirisukprasert, (1999), and it is a Three phase three Step bridge inverter for Adnan Tan, (2011), but it is a three phase 11- Step diode clamped multi-level inverter for the proposed model.
- Results are (THD=2.8%), (PF=0.95), (P=20kW), (Q=6kVAR) for Ibrahim.A. Altawil, (2011), while it is a line voltage THD = 12.3% (P=1.8KW), (PF= 0.92), (Q=2.5 KVRA) for Siriroj Sirisukprasert,

(1999), and they are (THD=1.8- 3.2%), (PF=31. 5), (P=0.95), (Q=4kVAR) Adnan Tan, (2011), but they are (THD=1.8%), (PF=0.99), (P=10MW), (Q=0.3MVAR) for the proposed model.

### 1.5 Power circuit topology

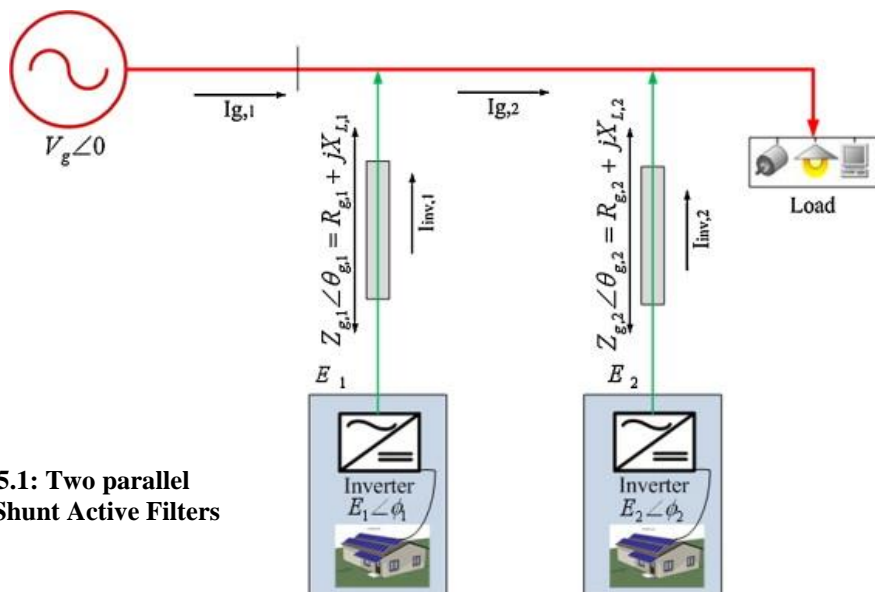
Many non-linear loads are the cause of non-sinusoidal current drawn from electrical power supply. This current will produce voltage harmonics when passing through different kind of power system impedances. The connected sensitive equipment which attached to the same power system will affected by these harmonics, (Hussien, Atan, Abidin,2003). To reduce these harmonics, regularly, passive filters (LC filters) used, but other unnecessary effects may occur it may result in parallel resonances with the network impedance. Active power filters is proposed to use instead of the passive filter due to the harmful of resonance. Improve the power quality without the disadvantages of passive filters is the main objective to use shunt active power filters.

The Power Circuit Topology will be explained by the headings below.

- 1- Two Inverter Shunt Active Filters (SAFS).
- 2- Hysteresis PWM current controller.
- 3- Generation of Reference current using p-q theories
- 4- Diode-clamped multilevel inverter

#### 1.5.1 Two Inverter Shunt Active Filters (SAFS)

SAFs are attached to the distribution line shunt, and they compensate the harmonics by injecting compensating currents. The injected currents magnitude is equals to the disturbances in the system magnitude but opposite in phase. This eliminates the harmonics in the transmission system to restore the waveforms of source voltage and source current sinusoidal again. Depending upon the objective of the SAF, harmonic compensation yields real power oscillations elimination; power factor correction or reduction of current harmonics from the distribution system. Constant real power compensation can be provided by SAPF by compensating the oscillating active power (P) and reactive power (Q) of the load.



**Figure 5.1: Two parallel inverters Shunt Active Filters**

#### 1.5.2 Hysteresis PWM current controller

The current controller of the hysteresis band for shunt active power filter can be approved for inverter switching pattern generation. The proposed current control methods has an assortment for the configurations of such active power filter, but in terms of immediate current controllability and straight forward the control method of hysteresis current has the biggest rate of implementation than other current control methods. Hysteresis band current controller has properties like sturdiness, fastest control, and tremendous dynamics with minimum hardware. (L. Hongda and K. Cao)

The conventional hysteresis band current control scheme used for the control of active power filter line current is shown in figure three, composed of active a hysteresis around the reference line current ( $I_L^*$ ) and actual line current of the active power filter is referred to as ( $I_L$ ). The hysteresis band current controller decides the switching pattern of active power filter. The switching logic is formulated as follows: (S. Buso, S. Fasolo, L. Malesani, P. Mattavelli, July 2000).

If  $I_L < (I_L^* - HB)$  upper switch of the leg is OFF and lower switch of the leg is ON.

If  $I_L > (I_L^* + HB)$  upper switch of the leg is ON and lower switch of the leg is OFF.

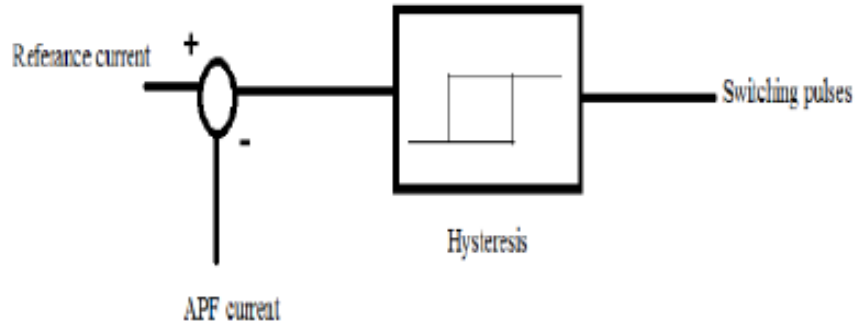


Figure 5.2: Conventional Hysteresis Band Current Controller

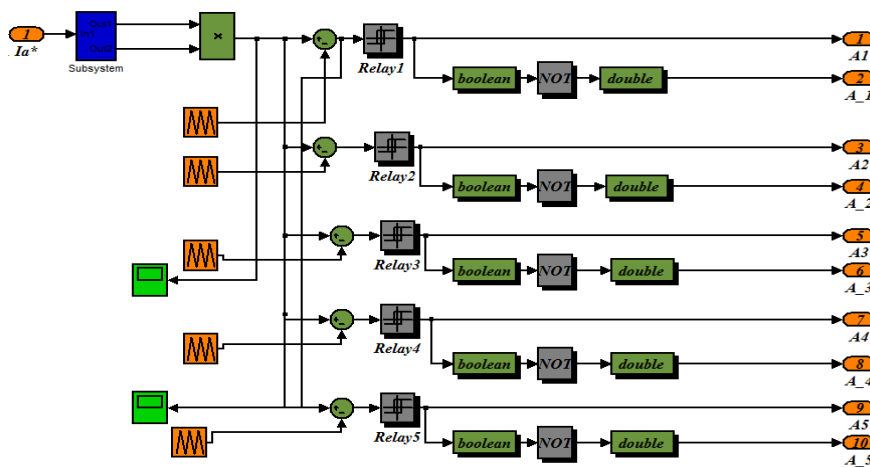


Figure 5.3: Simulation of Hysteresis Band Current Controller

### 1.5.3 Generation of Reference current using p-q theories

The three phase instantaneous reactive current ( $I_q$ ) and instantaneous active current ( $I_p$ ) are calculated by this theory based on instantaneous reactive power theory. The current and voltage vector is calculated according to the Clark transformation. The following equations illustrates the method to obtain the instantaneous values of currents and voltages in the ( $\alpha, \beta$ ) coordinates. (FERRACCI, 2001).

$$\begin{bmatrix} I_\alpha \\ I_\beta \end{bmatrix} = [A] \cdot \begin{bmatrix} I_a \\ I_b \\ I_c \end{bmatrix} \quad \begin{bmatrix} V_\alpha \\ V_\beta \end{bmatrix} = [A] \cdot \begin{bmatrix} V_a \\ V_b \\ V_c \end{bmatrix} \quad (5.1)$$

Where:

A: transformation matrix and obtained of (FERRACCI, 2001) .And given as:

$$A = \sqrt{\frac{2}{3}} \begin{bmatrix} 1 & -\frac{1}{2} & -\frac{1}{2} \\ 0 & \frac{\sqrt{3}}{2} & -\frac{\sqrt{3}}{2} \end{bmatrix} \quad (5.2)$$

The transformation can be used in case of that the voltages are balanced and sinusoidal, as a summary

$$V_a(t) + V_b(t) + V_c(t) = 0 \quad (5.3)$$

The instantaneous reactive and active power in the coordinates of  $\alpha, \beta$  is given according to the coming formula: (FERRACCI, 2001)

$$p(t) = V_a(t) \cdot I_\alpha(t) + V_\beta(t) \cdot I_\beta(t) \quad (5.4)$$

$$q(t) = -V_a(t) \cdot I_\beta(t) + V_\beta(t) \cdot I_\alpha(t) \quad (5.5)$$

According to the  $\alpha$ - $\beta$  plane, the equation of the currents as a function of the instantaneous power is addressed in the following expression:

$$\begin{bmatrix} I_\alpha \\ I_\beta \end{bmatrix} = \frac{1}{V_\alpha^2 + V_\beta^2} \cdot \left( \begin{bmatrix} V_\alpha & V_\beta \\ V_\beta & -V_\alpha \end{bmatrix} \cdot \begin{bmatrix} p \\ q \end{bmatrix} + \begin{bmatrix} V_\alpha & V_\beta \\ V_\beta & -V_\alpha \end{bmatrix} \cdot \begin{bmatrix} 0 \\ 0 \end{bmatrix} \right) = \begin{bmatrix} I_{\alpha p} \\ I_{\beta p} \end{bmatrix} + \begin{bmatrix} I_{\alpha q} \\ I_{\beta q} \end{bmatrix} \quad (5.6)$$

This yields that:

$$I_{\alpha p} = \frac{V_\alpha p}{V_\alpha^2 + V_\beta^2} \quad (5.7)$$

$$I_{\alpha q} = \frac{V_\beta q}{V_\alpha^2 + V_\beta^2} \quad (5.8)$$

$$I_{\beta p} = \frac{V_\beta p}{V_\alpha^2 + V_\beta^2} \quad (5.9)$$

$$I_{\beta q} = \frac{-V_\alpha q}{V_\alpha^2 + V_\beta^2} \quad (5.10)$$

Equations (5.4) and (5.5), expressed in terms of the AC components in addition to the DC components the values of p and q, which is:

$$p = \bar{p} + \tilde{p} \quad (5.11)$$

$$q = \bar{q} + \tilde{q} \quad (5.12)$$

Where:  $\bar{p}$  the instantaneous power (p) DC component, and belongs to the conventional fundamental active current.  $\tilde{p}$ : Is the instantaneous power (p) AC component and belongs to the harmonic currents caused by the instantaneous real power AC component.

$\bar{q}$ : Is the imaginary instantaneous power (q) DC component, and belongs to the reactive power generated by the voltages and currents fundamental components.

$\tilde{q}$ : Is the instantaneous imaginary power (q) AC component, and belongs to the harmonic currents caused by the instantaneous reactive power ac component.

The active power filter reference signal must have the values of  $\bar{p}, \bar{q}$  and  $\tilde{q}$  for compensation of the reactive power (displacement power factor) and non-linear loads current harmonics. The following equations calculate the reference currents needed by the active power filters:

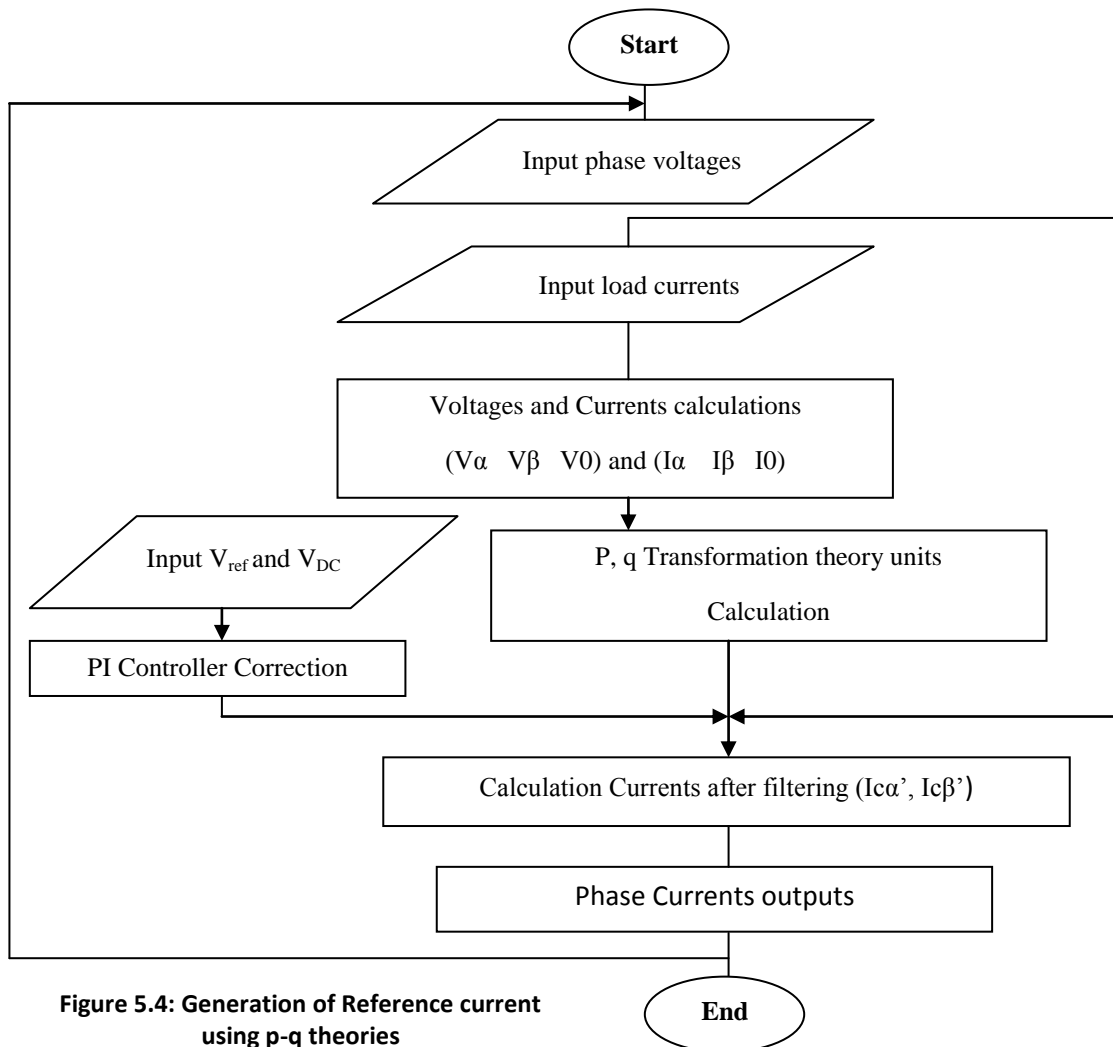
$$\begin{bmatrix} I_{c\alpha}^* \\ I_{c\beta}^* \end{bmatrix} = \frac{1}{V_\alpha^2 + V_\beta^2} \cdot \left( \begin{bmatrix} V_\alpha & V_\beta \\ V_\beta & -V_\alpha \end{bmatrix} \cdot \begin{bmatrix} \bar{p} \\ \bar{q} + \tilde{q} \end{bmatrix} \right) \quad (5.13)$$

The following matrix equation 5.14 presents the final compensating currents gathered with a, b, c reference frames zero sequence components:

$$\begin{bmatrix} I_{ca}^* \\ I_{cb}^* \\ I_{cc}^* \end{bmatrix} = \frac{1}{\sqrt{3}} \begin{bmatrix} 1/\sqrt{2} & 1 & 0 \\ 1/\sqrt{2} & -1/2 & \sqrt{3}/2 \\ 1/\sqrt{2} & -1/2 & -\sqrt{3}/2 \end{bmatrix} \begin{bmatrix} -I_0 \\ I_{ca}^* \\ I_{cb}^* \end{bmatrix} \quad (5.14)$$

Where the zero sequence current components

$$I_0 = \frac{1}{\sqrt{3}}(I_a + I_b + I_c). \quad (5.15)$$



**Figure 5.4: Generation of Reference current using p-q theories**

This block diagram (fig 5.4): chooses the instantaneous reactive power theory which we used to generate the reference current and measure the power and reactive power and power factor. First of all we transfer the phase voltage and load current from (a, b, c) reference frame to (0, α, β) reference frame, then we find the power and reactive power and power factor.

#### 1.5.4 Diode-clamped multilevel inverter

The shunt active power filter is operated as a controlled current source connected in parallel with the non-linear loads driven by PWM to inject current harmonics into the ac source. 11-steps diode clamped inverter is used in this work to generate compensation current (Z. F. Hussien, N. Atan, I. Z. Abidin, 2003) (F. Z. Peng, J-S Lai,

1996). A diode clamped multilevel inverter (M-level) inverter typically consists of (M-1) capacitors on the dc bus and produces M-levels on the phase voltage. Also it contains  $2*(M-1)$  switching devices and  $(M-1)*(M-2)$  clamping diodes. The dc voltage applied to the capacitors terminals, C1, C2, C3, C4 and C5 and each capacitor has a voltage  $V_{dc}/5$  and each devices voltage stress is limited to one capacitor voltage level through clamping diode. The numbering order of the switches is S1, S2, S3, S4, S5, S1\*, S2\*, S3\*, S4\* and S5\*.

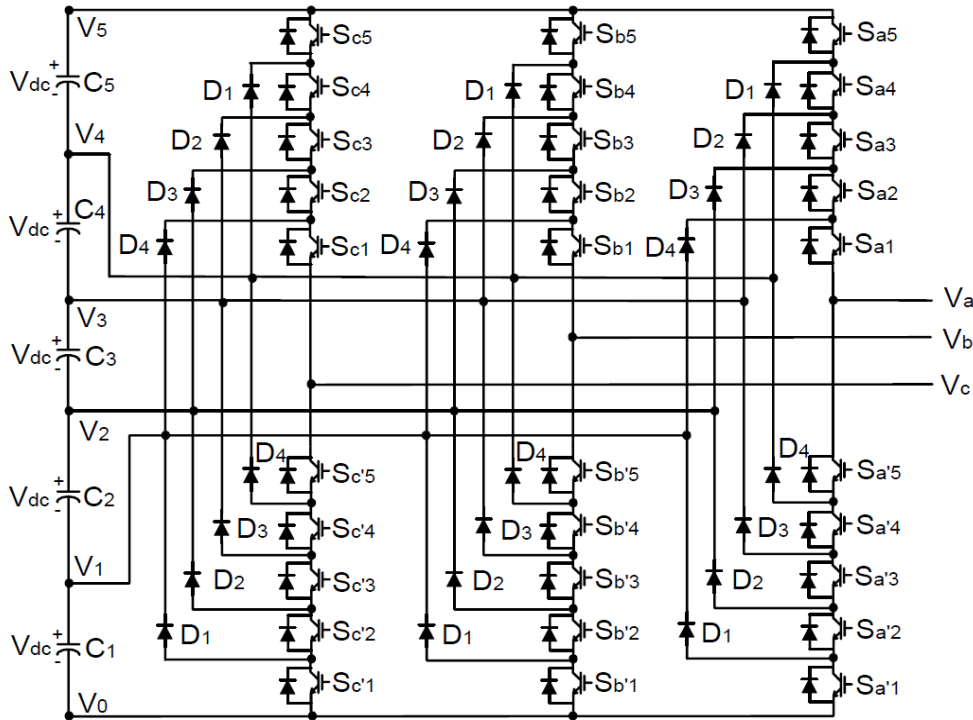


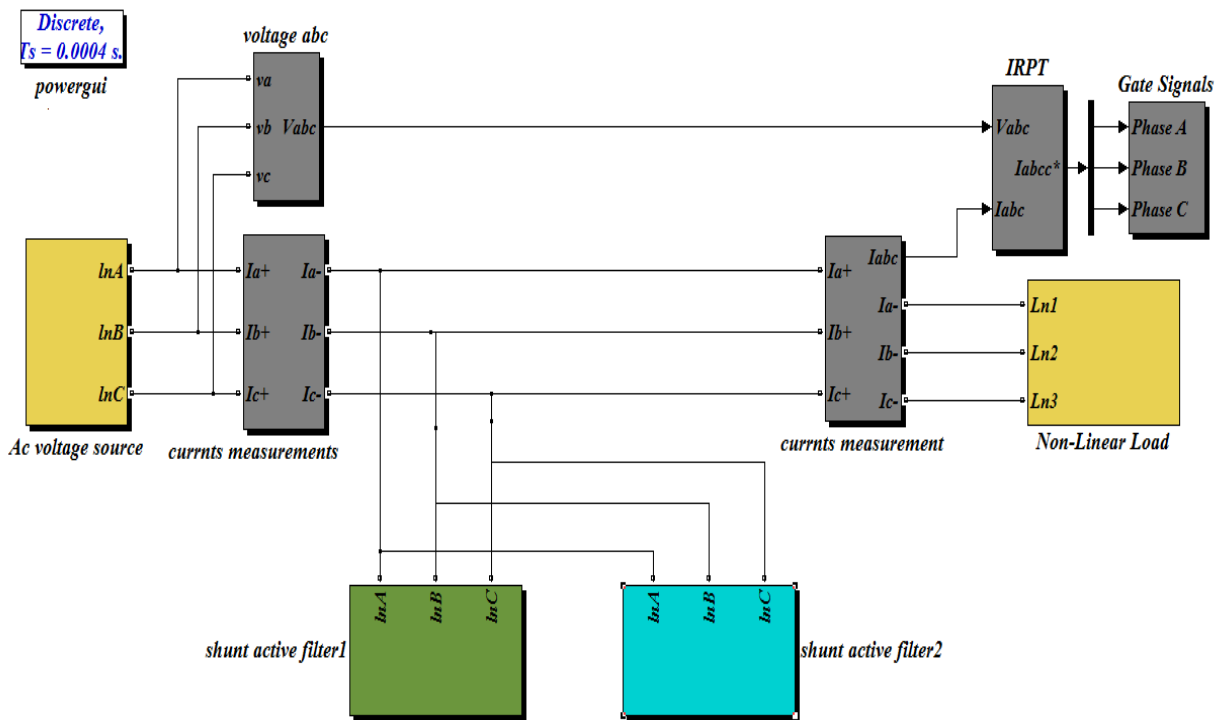
Figure 5.5: Structure of three-phase, 11-Step of a diode-clamped inverter

## 1.6 Simulation and Results

### 1.6.1 OVERALL CIRCUIT DIAGRAM (SIMULATION MODEL): Fig 6.1

The overall **diagram** of the simulation circuit contains in the table 6.1

Table 6.1: system parameters	
Parameter	Value
Source Voltage $V_s$	11KV <sub>p-p</sub>
Source frequency f	50 Hz
Voltage phase angle	$0^\circ$
Source resistance $R_s$	0.1 $\Omega$
Source Inductance $L_s$	10 mH
Load inductance $L_r$	1.5 mH
Load Resistance $R_r$	20 $\Omega$
<b>Armature Dc Motor</b> Load inductance $L_r$	<b>3 H</b>
<b>Armature Dc Motor</b> Load Resistance $R_r$	<b>2 <math>\Omega</math></b>
<b>Field Dc Motor</b> Load inductance $L_r$	<b>13 H</b>
<b>Field Dc Motor</b> Load Resistance $R_r$	<b>84<math>\Omega</math></b>
<b>Field of Dc Motor</b>	<b>400 V</b>



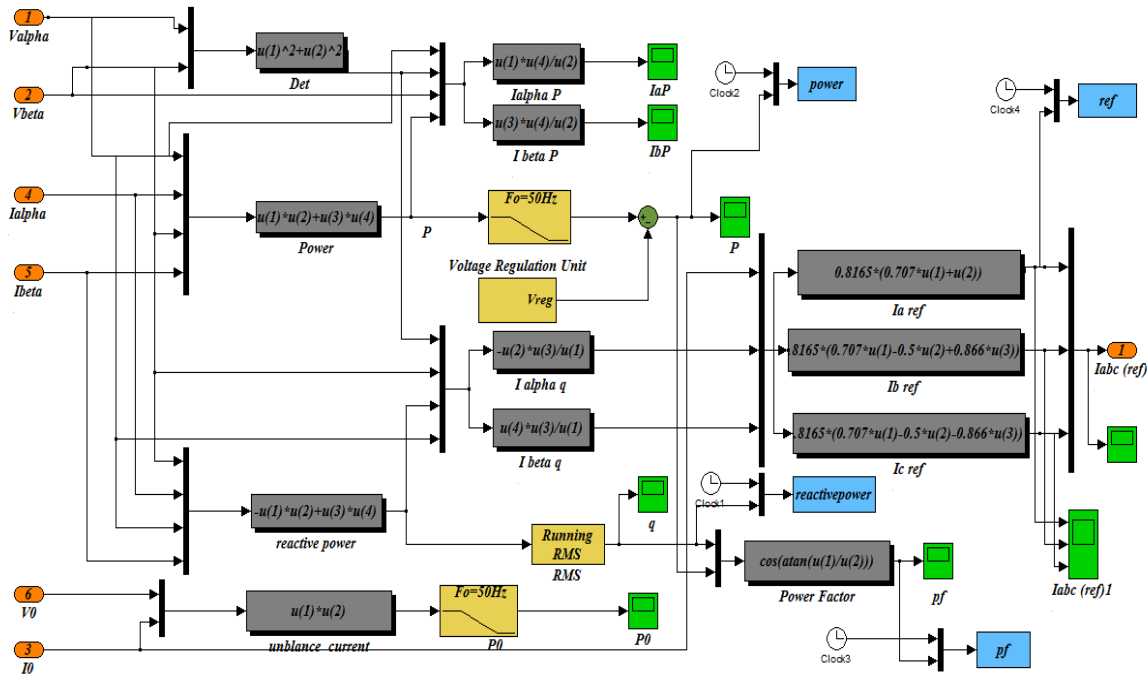
**Fig 6.1: Overall circuit diagram.**

This figure is show overall system which mainly consists of:

1. AC voltage source.
2. Nonlinear load.
3. Two inverter Shunt active power filters (SAPF).
4. Instantaneous reactive power model (IRPT).
5. Gate signal (hysteresis band current control).
6. Discrete time.

Instantaneous reactive power theory is used in simulation to generate the reference of main system elements of current, power, reactive power and power factor which it is used in the current control of hysteresis band. The current control signals compared with actual current to produce the gating signal, figure 6.2 represent the instantaneous reactive power simulation.



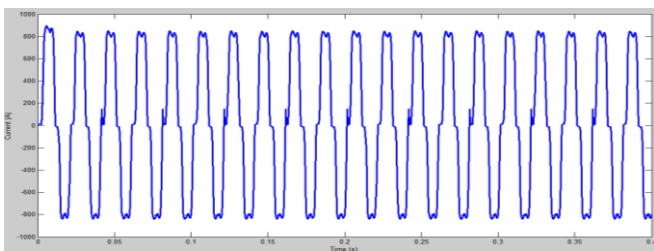


**Fig 6.2: Inside instantaneous reactive power simulation.**

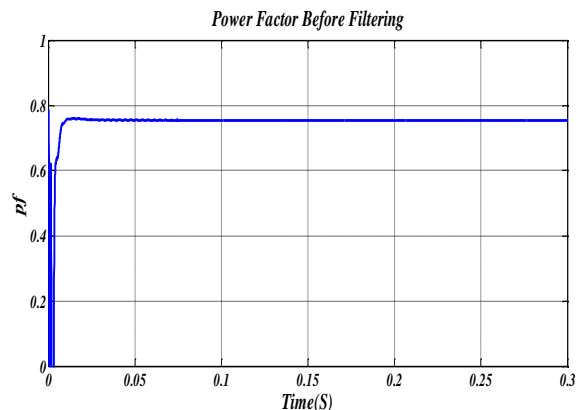
Fast Fourier Transform (FFT) is suitable algorithms to discrete time sinusoidal signals founded in modern software such as Mat lab. FFT algorithm required in discrete Fourier transforms (DFT) computation as well as FFT inverse. FFT algorithms have varied type's mentions as involving, number theory, group theory and also the arithmetic of simple complex-number.

In MATLAB/Simulink, FFT algorithms used to explore the compensated source current. This tool is very simple and easy to use. The main reason of used FFT is to order of harmonics by analyses the source current in the system. Otherwise, FFT gives the proportion of harmonics magnitude with respect to fundamental magnitude. Many features can found in this tool it can compute the signal and make many operations such as Total Harmonic Distortion (THD). Figure 6.3 (c), 6.4 (b) and 6.5 (b) represents the current source fast Fourier transform (FFT) analysis without SHAPF (THD = 20.18%) which is connected with one inverter SHAPF (THD = 4.35%). also with connected two inverters SHAPF (THD = 2.05%) which shows further decies in THD when using two inverter SHAPF for medium distribution system 11Kv is less than 5% the harmonic limit imposed by IEEE-519 standard.

By using the initial elements and parameter represented on figure 6.1, and the diode rectifier of three phase with impedance  $R = 20 \Omega$ ,  $L = 1.5 \text{ mH}$  as a load, the system simulated from  $t=0 \text{ s}$  to  $t=0.4\text{s}$ . To be illustrated to only balance three phase load is considered, the three phase load current is very high distorted. Otherwise, figure 6.3 (a) represents the pre-compensation current source.

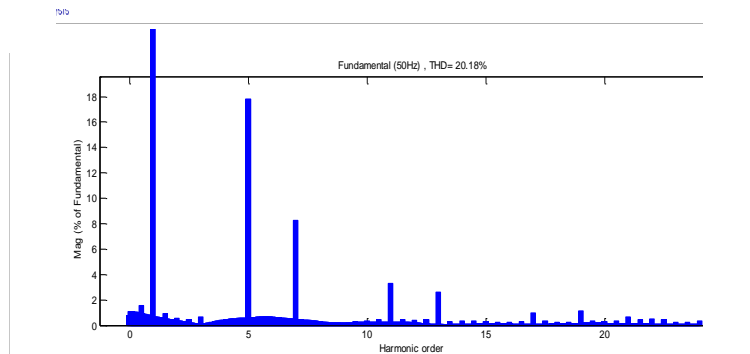


**Fig 6.3 (a): unfiltering Load current.**



**Fig 6.3 (b): (APF) unless power factor (PF=0.77%).**

Figure 6.3 (a) shows the highly distorted load current in the simulation.



**Fig 6.3 (c): (FFT) unless APF for source current. (THD =20.18%).**

Figure 6.3 (c) deepened on choose of the harmonic in the source current unless active power filters. The figure represents a high destroyed as we see. Furthermore, the total harmonic distortion is very high (20.18%) and the most appearance harmonic is in the fifth.

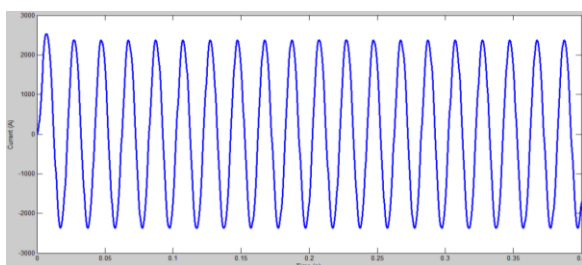
Typically, by studying the steady state conditions, a small comparison must represented on thesis about the waveforms before and after load also between source currents with two and one inverters APF and study the effects on the harmonics

In the transient state conditions, it was observed that when the load current before and after filtering is increased and becomes more sinusoidal from 0.1 to 0.2, resulting that the harmonics is decreased. But the harmonics are not the same in Steady state and Transient state.

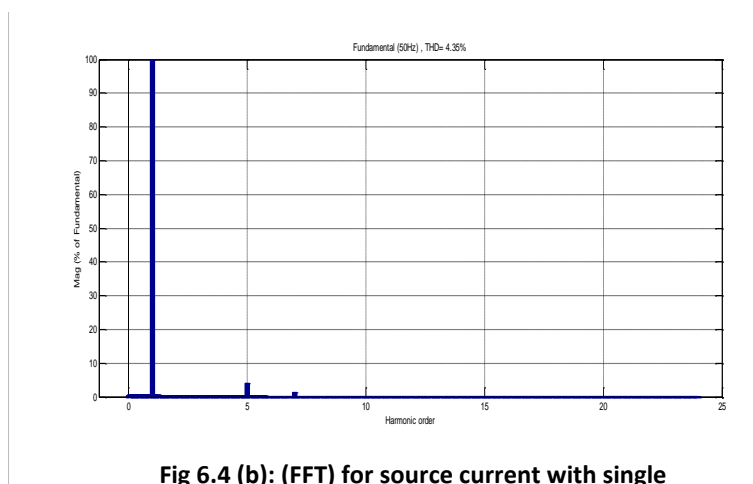
### 6.3 CASE1: STEADY STATE CONDITION

Two parallel inverters Shunt Active Power Filter (SHAPF) model is considered to a study state condition. Study state test is made to evaluate the response of the two parallel SHAPF inverters. on this thesis focused to design a simulation to study the behavior of distribution power system with one inverter shunt active power filter (SHAPF), and with two parallel inverter together without shunt active power filter (SHAPF) to ensure that the SHAPF is able to compensate the current harmonic which produced by non-linear load and compare the best way to choose solution.

Figure 6.4 (a) represents the post-compensation current source with single inverter for particular phase A. This shows the current have a sinusoidal form SHAPF inverter is illustrated in Figure 6.4



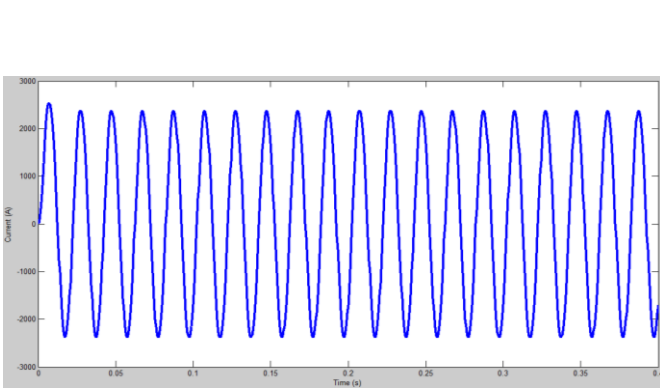
**Fig 6.4 (a): Source current with filtering and single inverter.**



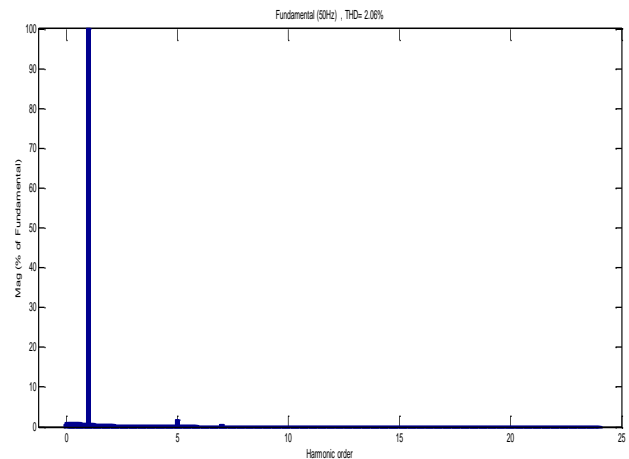
**Fig 6.4 (b): (FFT) for source current with single inverter (THD =4.35%).**

Figure 8.10 deepened on the parameters of the harmonic from the source current after using single inverter active power filter which is become small. The total harmonic distortion around (4.35%) which is a small and the most appearance harmonic is around fifth.

The particular phase current source after compensation with two inverters Shunt Active Power Filter (SHAPF) presented in Figure 8.11a to indicate that the current become more sinusoidal. Figure 8.11b represents the three phase's current and the THD by using two inverters Shunt Active Power Filter (SHAPF) is shown in figure 8.11.c. The results shows that when using two inverters is much better

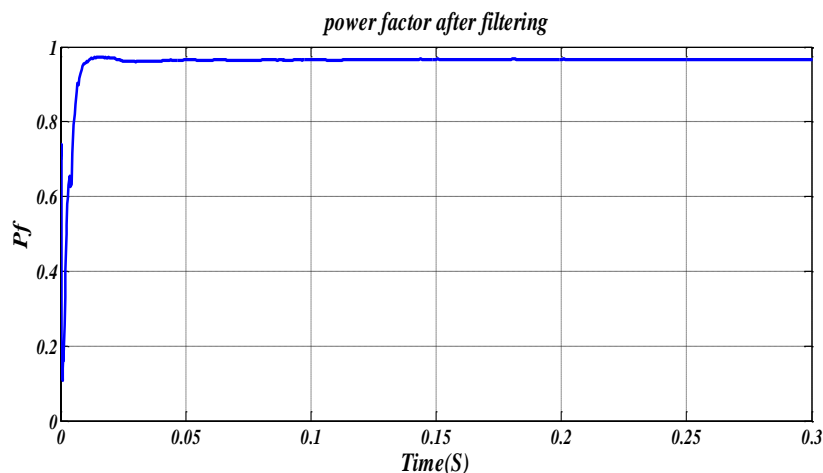


**Fig 6.5 (a): Source current with filtering and two inverters.**



**Fig 6.5 (b): FFT for source current and two inverter (THD =2.05 %).**

Figure 6.5 (b) consider to choose the harmonic of the source current after using two inverter active power filter which is become very small and the total harmonic distortion around (2.05%) and the most appearance harmonic is the are the fifth. Figure 6.7 (a) represents that that the power factor correction was achieved.



**Fig 6.7 (a): Total PF with APF.**

Each figures 6.7 (b) and 6.7 (c) represents the steady state conations with and without APF, the active and reactive power at the diode rectifier load.

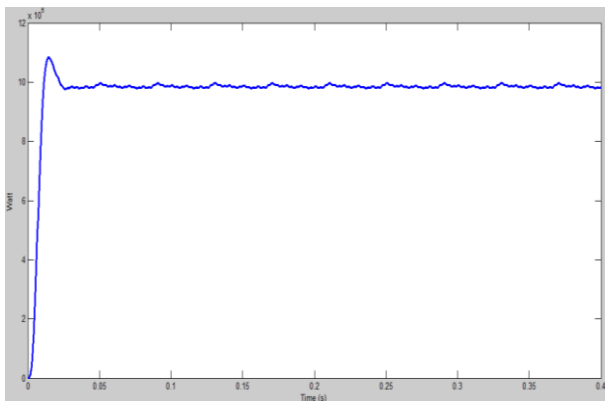


Fig 6.7 (b): Active power of the load.

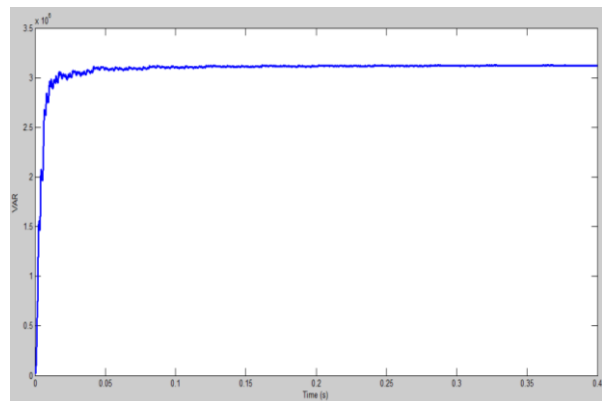


Fig 6.7 (c): Reactive power of the load.

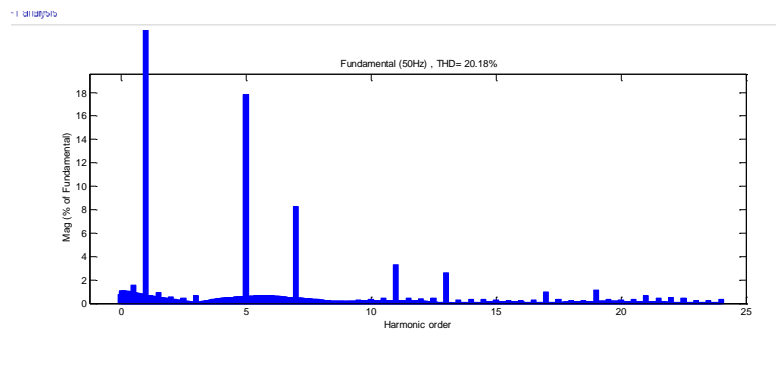


Fig 6.8 (a): Source current (FFT) unless APF with THD =20.18%.

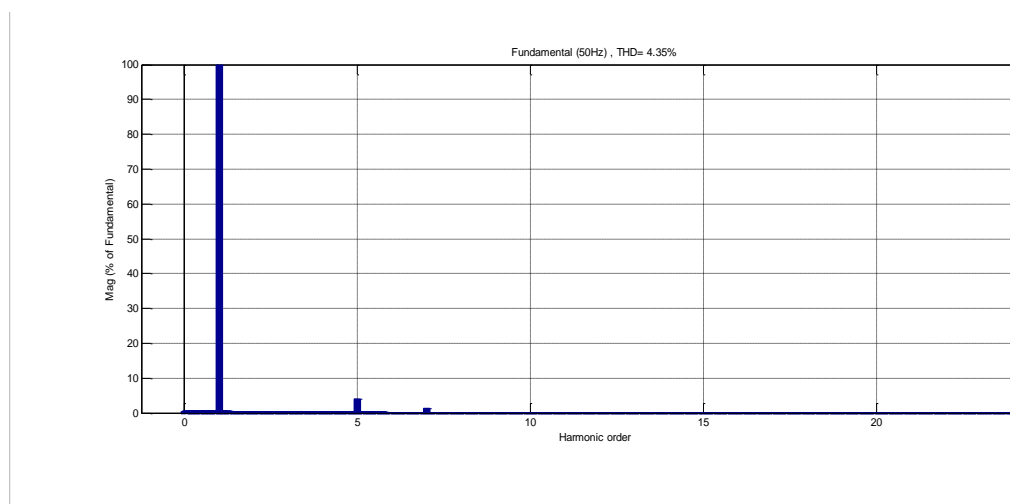
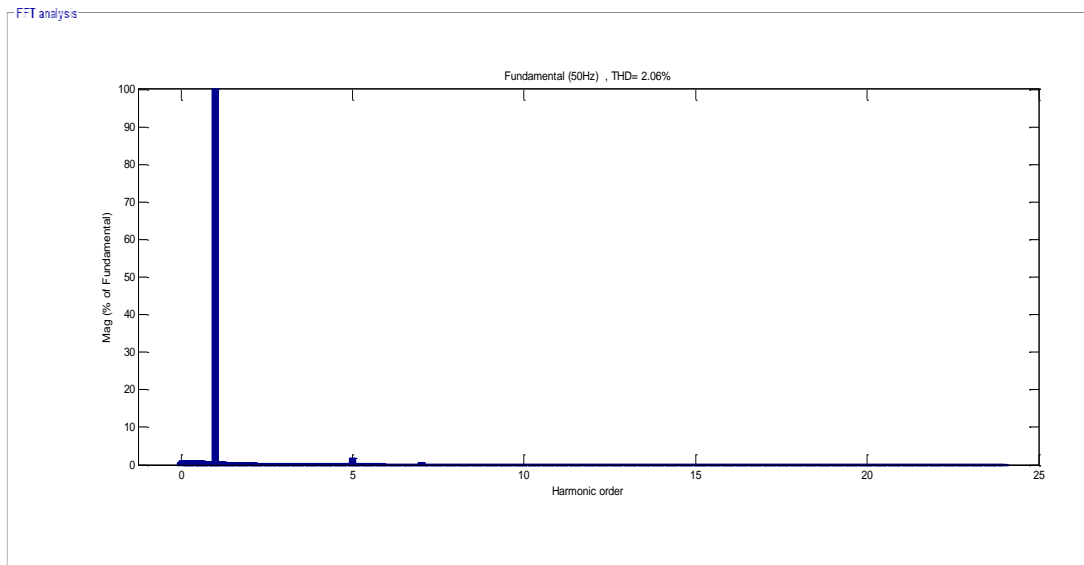


Fig 6.8 (b): (FFT) for source current cabled with single inverter (THD=4.35 %).

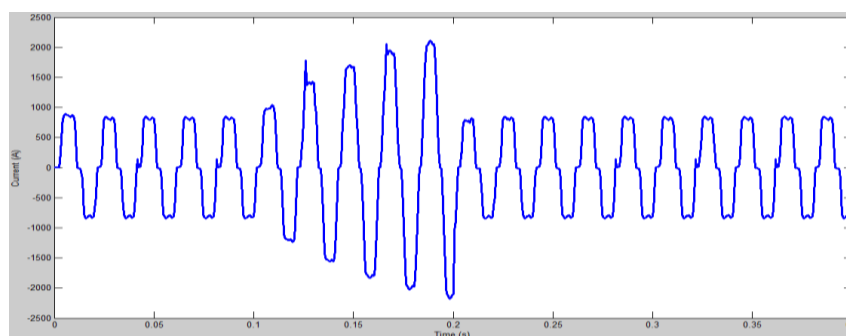


**Fig 6.8 (c): (FFT) for source current with two inverter**

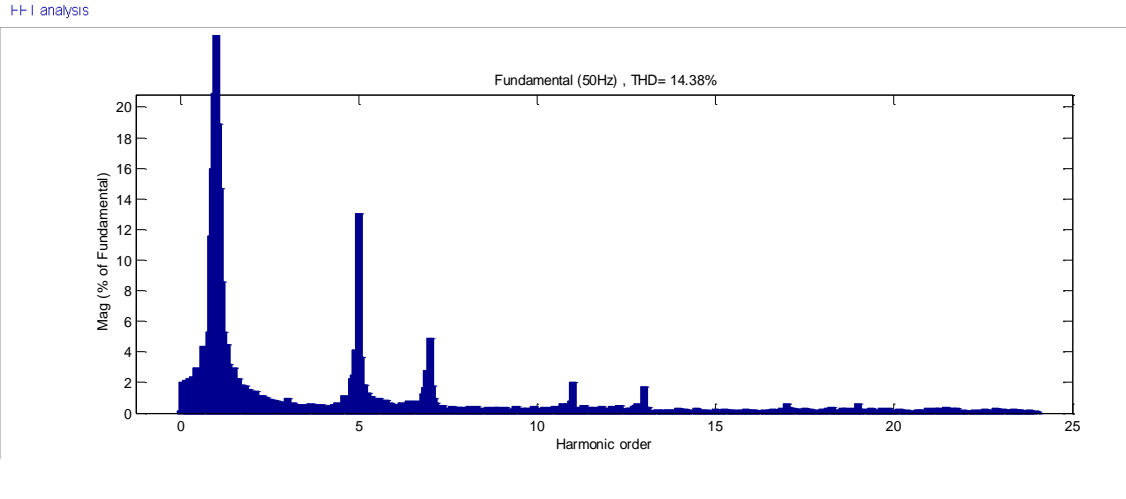
#### 8.4 CASE 2 TRANSIENT STATE CONDITIONS:

In this condition of study, we consider to turn on both systems we can see that the effects on the transient system is greater than the steady state (harmonics), one inverter SHAPF and two inverters SHAPF model are presented to a transient condition. The transient test is used to evaluate the response and waveforms of the shunt active power filter (SHAPF). This simulation is modeled under environment of MATLAB/ Simulink to ensure that the shunt active power filter (SHAPF) is able to recover from this transient condition without affecting on the stability of the overall system.

To declare the idea the DC motor load is added in parallel during period of time and the transient behavior of the system was studied. The motor parameters summarized on table 6.1. The current waveform and the Total Harmonic Distortion (THD) shown in Figure 6.9 (a, b) respectively

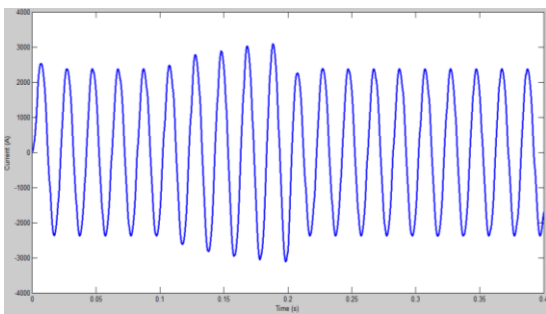


**Fig.6.9 (a): transient condition with load current without filtering.**

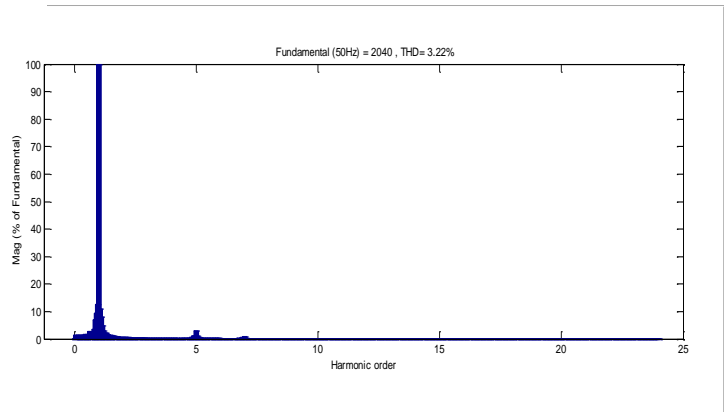


**Fig 6.10 (b) : Source current (FFT) unless two inverters (THD =14.38%).**

Figure 6.10 (a) represents the current source for particular phase after compensation with one inverter SHAPF, we can mention and shows that the current is more sinusoidal and in this area the harmonic is decrease between 0.1 to 0.2, the THD by using two inverter SHAPF is shown in figure 6.10 (b).

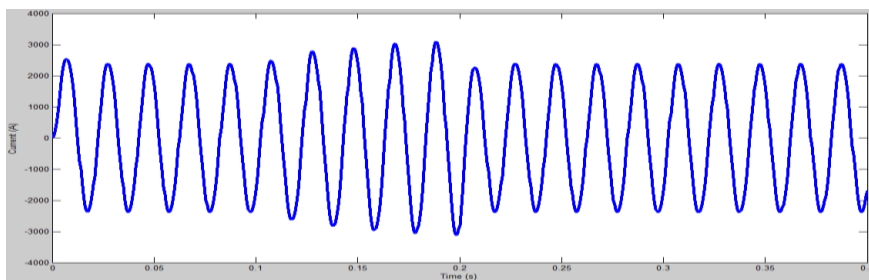


**Fig 6.10 (a): transient source current filter with APF.**

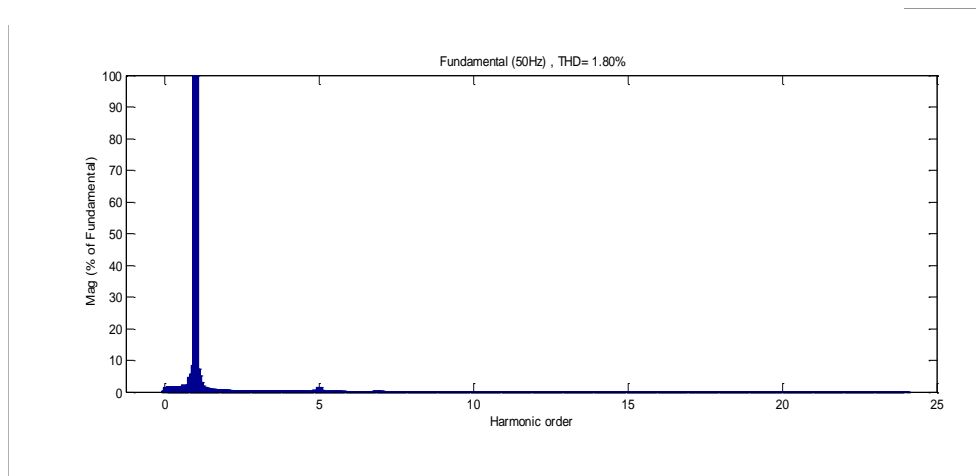


**Fig 6.10 (b): (FFT) for source current by using single inverter (THD =3.22%).**

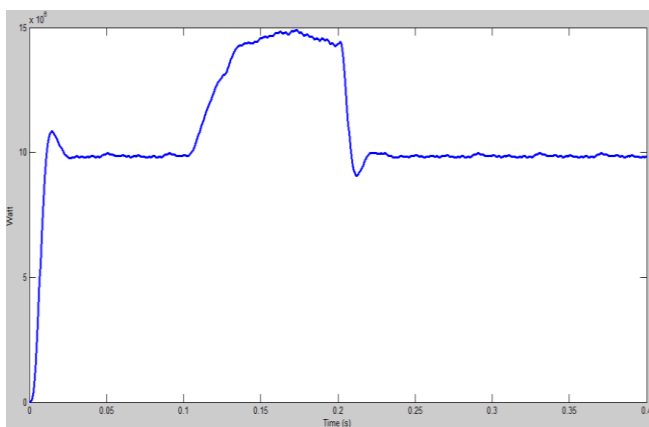
Figure 6.11 (a) represents the current source for a particular phase after compensation with two SHAPF inverters which is depicted, we can see that the current is enhanced to be more sinusoidal and in this area the harmonic is decrease between 0.1 to 0.2, the THD by using two inverters SHAPF is shown in figure 6.11 (b).



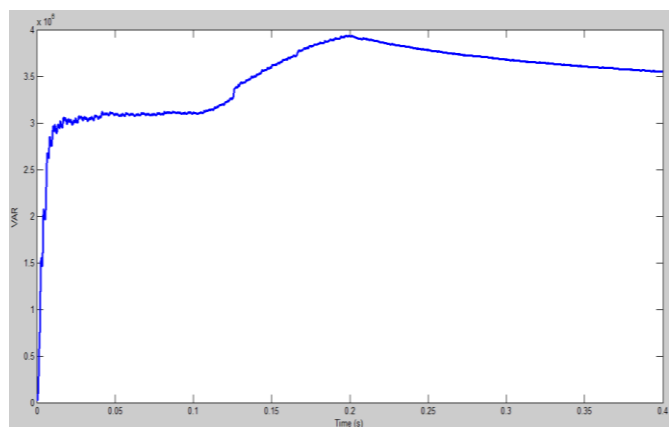
**Fig 6.11 (a): transient source current filter with two inverters.**



**Fig 6.11 (b): (FFT) for source current with two inverters (THD =1.80%).**



**Fig 6.12 (a): Active power of the load.**



**Fig 6.12 (b): Reactive power of the load.**

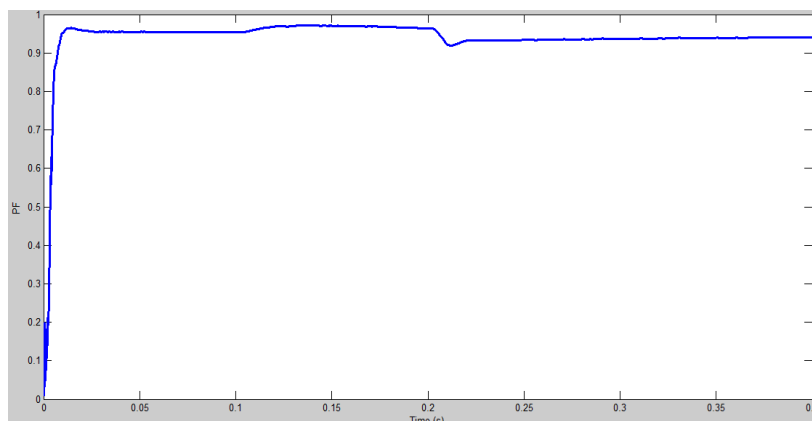
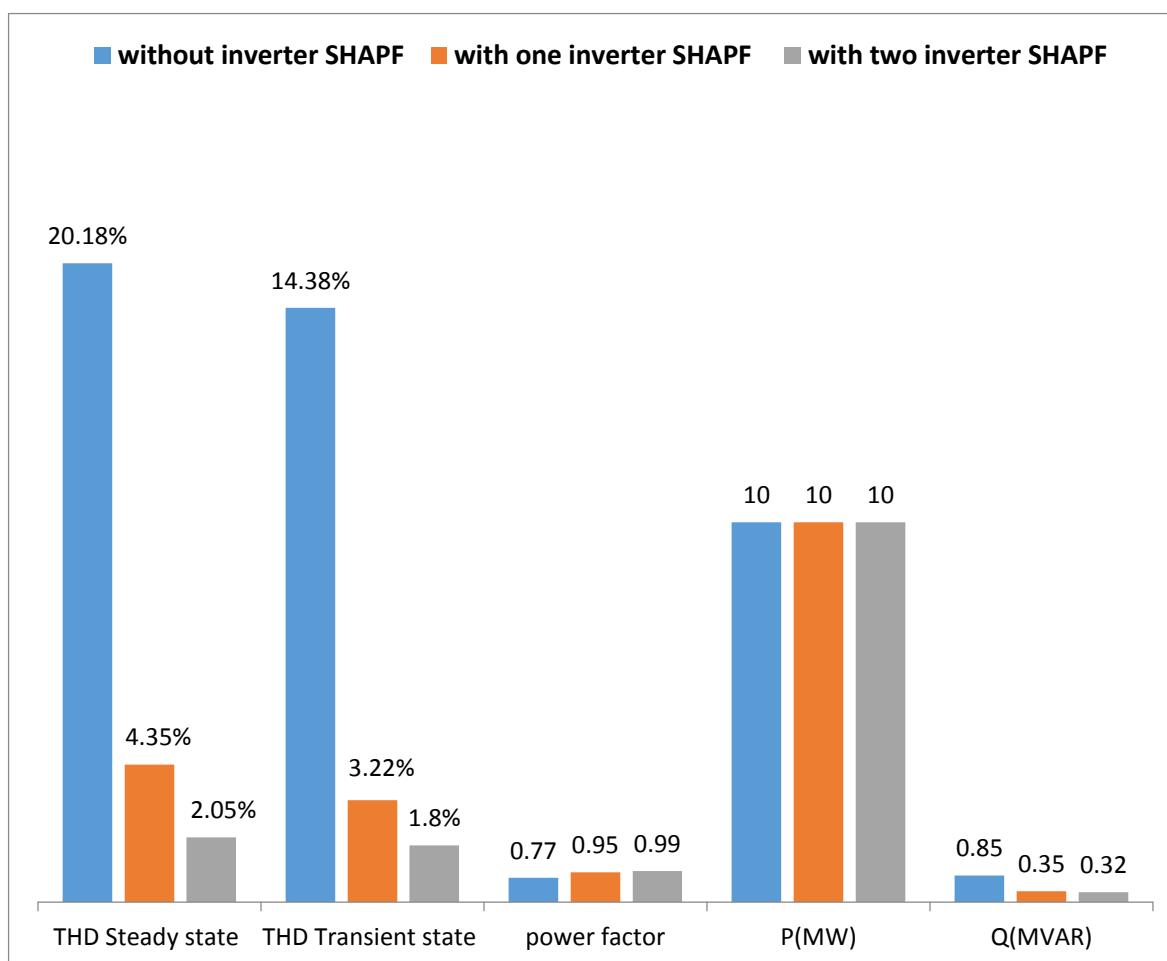


Fig 6.13: Total power factor with (APF).

Table 6.2: Summary results.





## 1.7 CONCLUSIONS

In recent years, most researchers studied a Shunt Active Power Filters (SAPF) based on conventional two-shunt inverter with conventional controllers that requires a complex and a complicated mathematical model. In order to overcome this problem in the literature a Hysteresis band controller based diode clamped multilevel inverter has been implemented and extended. In my thesis deal with implementing and design of three phase two inverters shunt Active Power Filter (APF), in distribution system 11KV to enhance the reactive power and so eliminate harmonics from a typical non-linear load, composed from (uncontrolled bridge rectifier with inductive load and DC motor). In this research, almost a unity power factor and sinusoidal current source is achieved. The current source total harmonic distortion (THD) after compensation by single inverter is 4.35% but by using two inverters it decreases to 2.05% which is agreed and less than the harmonic limit imposed by the IEEE-519 standard (3%), by using two parallel inverters with 11-Step diode clamped multi-level inverter the circuit is simulated by using MATLAB/ Simulink.

## REFERENCES

- R. C. Dugan, M. F. McGranaghan, S. Santosa, and H. W. Beaty, "Electrical Power Systems Quality", second edition, McGraw-Hill, 2002.
- C. Sankaran, "Power Quality, the Electric Power Engineering Series", CRC PRESS, 2002.
- Philippe FERRACCI, "Power Quality, Cahier technique", Cahiers Techniques Electric, 2001, – No. 199.
- Lundquist, Johan, Associated power technologies, "Total harmonic distortion and effects in electrical power systems", 2001.
- Alexander Kusko, Marc Thompson, McGraw Hill P.C. Power Quality in Electrical Systems, 2007.
- Angelo Baggi. 'Hand book of power quality', John Wiley and Sons, Ltd. The Atrium, Southern Gate, Chichester, West Sussex PO19 8SQ, England.
- Francisco C. De La Rosa, Harmonics and Power Systems, The Electric Power Engineering Series, Taylor & Francis Group, 2006.
- J. David Irwin, Power electronics handbook, Auburn University, Series editor.
- Lander, Cyril W. (1993). "Rectifying Circuits". Power electronics (3rd ed. ed.). London: McGraw-Hill. ISBN 9780077077143.
- Z. F. Hussien. N. Atan, I. Z. Abidin, "Shunt active power filter for harmonic compensation of nonlinear loads", 0-7803-8208-0/03/\$17.00©2003 IEEE.
- R. S. Herrera, P. Salmeron, "Instantaneous Reactive Power Theory: A Reference in Nonlinear Loads Compensation", IEEE TRANSACTIONS ON INDUSTRIAL ELECTRONICS, VOL. 56, NO. 6, JUNE 2009.
- Guichum Huang, "The algorithm of a reference compensation current for Shunt Active Power Filters control", 978-0-7695-4116-7/10 \$26.00 © 2010 IEEE.
- L. Hongda and K. Cao, "Active power filter simulation based on instantaneous reactive power theory and the PWM hysteresis control mode", 978-1-4244-8161-3/11/\$26.00©2011 IEEE.
- S. Buso, S. Fasolo, L. Malesani, P. Mattavelli, "A dead beat adaptive hysteresis current control", IEEE Transactions on industry applications, Vol.36, no.4, pp1174-1180, July 2000.
- M. Kale, E. Ozdemir, "A novel adaptive hysteresis band current controller for shunt active power filter", 0-7803-7729-X/03/\$17.00©2003 IEEE.
- F. Z. Peng, "Application Issues of active power filters", IEEE Industry applications magazine-September/October 1998, 1077-2618/98/\$10.00 © 1998 IEEE.
- A.de. Almeida, L. Moreira, J. Delgado "Power quality problems and new solutions", Department of Electrical and Computer Engineering, University of Coimbra, Pádo II, Coimbra (Portugal).
- H. Akagi, Y. Kanazawa, and A. Nabae, "Generalized theory of the instantaneous reactive power in three-phase circuits," in Proc. IPEC, Tokyo, Japan, 1983, pp. 1375-1386.
- Modern power electronics and AC drives, Bimal K. Bose, Prentice hall PTR 2000, ISBN 0-13-016743-6.