

Closed Form Expressions for Delay to Ramp Inputs for On-Chip VLSI RC Interconnect

Vikas Maheshwari, Prabhakar Sharma

¹Deptt. Of ECE, Anand Engineering College, Keetham, Agra, U.P., INDIA

Alka Goyal, Vimal K. Yadav

²Deptt of ECE, Hindustan College of Science and Technology, Mathura, U. P. INDIA

Sampath Kumar

³JSS Academy of Technical Education, Noida , U.P. INDIA

maheshwari_vikas1982@yahoo.com, prabhakar.sh@gmail.com

Abstract

In high speed digital integrated circuits, interconnects delay can be significant and should be included for accurate analysis. Delay analysis for interconnect has been done widely by using moments of the impulse response, from the explicit Elmore delay (the first moment of the impulse response) expression, to moment matching methods which creates reduced order trans impedance and transfer function approximations. However, the Elmore delay is fast becoming ineffective for deep submicron technologies, and reduced order transfer function delays are impractical for use as early-phase design metrics or as design optimization cost functions. This paper describes an approach for fitting moments of the impulse response to probability density functions so that delay can be estimated accurately at an early physical design stage. For RC trees it is demonstrated that the inverse gamma function provides a provably stable approximation. We used the PERI [13] (Probability distribution function Extension for Ramp Inputs) technique that extends delay metrics for ramp inputs to the more general and realistic non-step inputs. The accuracy of our model is justified with the results compared with that of SPICE simulations.

Keywords— Moment Matching, On-Chip Interconnect, Probability Distribution function, Cumulative Distribution function, Delay calculation, Slew Calculation, Beta Distribution, VLSI.

1. Introduction

The advent of sub-quarter-micron IC technologies has forced dramatic changes in the design and manufacturing methodologies for integrated circuits and systems. The paradigm shift for interconnect which was once considered just a parasitic but can now be the dominant factor to determine the integrated circuit performances. It results the greatest impetus for change of existing methodologies. Over the past decade there have been a number of advances in modeling and analysis of interconnect that have facilitated the continual advances in design automation for systems of increasing frequency and downsizing. As integrated circuit feature sizes continue to scale well below 0.18 microns, active device counts are reaching hundreds of millions [3]. The amount of interconnect among the devices tends to grow super linearly with the transistor counts, and the chip area is often limited by the physical interconnect area. Due to these interconnect area limitations, the interconnect dimensions are scaled with the devices whenever possible. In addition, to provide more wiring resources, IC's now accommodate numerous metallization layers, with more to come in the future. These advances in technology that result in scaled, multi-level interconnects may address the wireability problem, but in the process creates problems with signal integrity and interconnect delay. This paper proposes an extension of Elmore's approximation [1] to include matching of higher order moments of the probability density function. Specifically, using a time-shifted incomplete Gamma function approximation [2] for the impulse responses of RC trees, the three parameters of this model are fitted by matching the first three central moments (mean, variance, skewness), which is equivalent to matching the first two moments of the circuit response (m_1 , m_2). Importantly, it is proven that such a gamma fit is guaranteed to be realizable and stable for the moments of an RC tree [4]. Once the moments are fitted to characterize the Gamma function, the step response delay and slew are obtained as a closed form expression thereby providing the same explicitness as the Elmore approximation.

In this work, we used PERI technique[13] for extending any delay metric derived for a step input into a delay metric for a ramp input for RC trees that is valid over all input slews. A noteworthy feature of this method is that the delay metric reduces to the Elmore delay of the circuit under the limiting case of an infinitely slow ramp, a fact first proved in [5] to establish the Elmore delay as an upper bound.

The remainder of the paper is organized as follows. Section 2 presents pertinent background information relating probability and circuit theory. Section 3 shows our techniques for extending step delay and slew metrics to ramp inputs. Section 4 presents experimental results that both validate the effectiveness of our approach. Finally, we conclude the paper in Section 5.

2. Basic Theory

2.1 Moments of a Linear Circuit Response

Let $h(t)$ be a circuit impulse response in the time domain and let $H(s)$ be the corresponding transfer function. By definition, $H(s)$ is the Laplace transform of $h(t)$ [12],

$$H(s) = \int_0^{\infty} h(t)e^{-st} dt \quad (1)$$

Applying a Taylor series expansion of e^{-st} about $s = 0$ yields,

$$H(s) = \sum_{i=0}^{\infty} \frac{(-1)^i}{i!} s^i \int_0^{\infty} t^i h(t) dt \quad (2)$$

The i^{th} circuit-response moment, \tilde{m}_i is defined as [5]:

$$\tilde{m}_i = \frac{(-1)^i}{i!} \int_0^{\infty} t^i h(t) dt \quad (3)$$

From (2) and (3), the transfer function $H(s)$ can be expressed as:

$$H(s) = \tilde{m}_0 + \tilde{m}_1 s + \tilde{m}_2 s^2 + \tilde{m}_3 s^3 + \dots \quad (4)$$

2.2 Central Moments

Similar to moments, central moments are distribution theory concepts. Following Elmore's distribution function analogy, we can use them to explain the properties of Elmore delay approximation.

Consider the moment definition given in again:

$$\tilde{m}_q = \frac{(-1)^q}{q!} \int_0^{\infty} t^q h(t) dt \quad (5)$$

The mean of the impulse response is given by [9-10],

$$\mu = \frac{\int_0^{\infty} th(t) dt}{\int_0^{\infty} h(t) dt} = \frac{-m_1}{m_0} \quad (6)$$

It is straightforward to show that the first few central moments can be expressed in terms of circuit moments as follows [11]:

$$\left. \begin{aligned} \mu_0 &= m_0 \\ \mu_1 &= 0 \\ \mu_2 &= 2m_2 - \frac{m_1^2}{m_0} \\ \mu_3 &= -6m_3 + 6\frac{m_1 m_2}{m_0} - 2\frac{m_1^3}{m_0^2} \end{aligned} \right\} \quad (7)$$

Unlike the moments of the impulse response, the central moments have geometrical interpretations:

μ_0 is the area under the curve. It is generally unity, or else a simple scaling factor is applied.

μ_2 is the variance of the distribution which measures the spread or the dispersion of the curve from the center. A larger variance reflects a larger spread of the curve.

μ_3 is a measure of the skewness of the distribution; for a unimodal function its sign determines whether the mode (global maximum) is to the left or to the right of the expected value (mean). Its magnitude is a measure of the distance between the mode and the mean.

2.3 Higher Central Moments in RC Trees

The second and third central moments are always positive for RC tree impulse responses [6]. The positiveness of the second order central moment is obvious from its definition

$$\mu_2 = \int_0^{\infty} (t - \mu)^2 h(t) dt \quad (8)$$

The impulse response, $h(t)$, at any node in an RC tree is always positive. Hence the second central moment μ_2 is always positive.

3. Proposed Model

Elmore approximated the interconnect delay based on the analogy between non-negative impulse responses and Probability Distribution Function (PDF). Elmore's distribution interpretation can be extended beyond simply estimating the median by the mean if higher order moments can be used to characterize a representative distribution function. In order to capture the RC interconnect delay various probability functions have been used with varying accuracy. The Beta distribution is a reasonably good representation of RC tree impulse responses since it provides good "coverage" of bell shaped curves which are bounded on the left and exponentially decaying to the right.

Beta distribution is two parameter continuous functions, which is given by the following formula [14],

$$B(a, b) = \int_0^1 u^{a-1} (1-u)^{b-1} du \quad (9)$$

Where $a, b > 1$ and are shape parameters.

The probability density function for the beta distribution is defined [14] as below.

$$P(a, b) = \frac{1}{B(a, b)} x^{a-1} (1-x)^{b-1} \quad (10)$$

And the domain of the beta distribution is given by, $0 \leq X \leq 1$

After some mathematical manipulation, using [15], the Cumulative Density Function is given by [14]

$$I_x(a, b) = \frac{1}{B(a, b)} \int_0^x t^{(a-1)} (1-t)^{(b-1)} dt \quad (11)$$

One can easily generate the PDF of Beta distribution by using Matlab. Figure 1 given below is the Beta distribution PDF with $P(a, b)$ on y-axis and X on x-axis which is generated in Matlab 7.5.0 for different values of constants a and b .

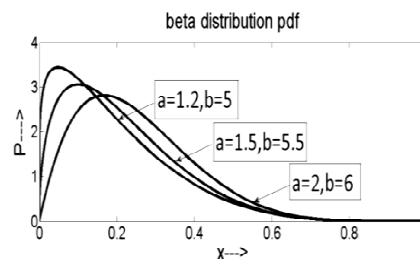

Figure 1: Beta distribution PDF for Different values of constants a and b

The area under each curve is unity. It is clear from the figure above that the PDF of Beta Distribution is analogous to the impulse function.

3.1 Calculation of the Delay Metric

Now the expressions of Mean (μ) and Variance (σ^2) and Skewness (μ_3) [12] is given by

$$\mu = \frac{a}{a+b} \quad (12)$$

$$\sigma^2 = \frac{ab}{(a+b)^2(a+b+1)} \quad (13)$$

$$\mu_3 = \frac{2(b-a)(a+b+1)^{1/2}}{(a+b+2)(ab)^{1/2}} \quad (14)$$

One can match three common properties of the Beta distribution and the circuit's impulse response. Note that the mean, variance and skew of the impulse response are $\mu = -m_1$ and $\sigma^2 = 2m_2 - m_1^2$, $\mu_3 = -6m_3 + 6m_1m_2 - 2m_1^3$ respectively.

Using (12) and (14), by matching the mean and Skewness yields,

$$\mu = -m_1 = \frac{a}{a+b} \quad (15)$$

$$\mu_3 = -6m_3 + 6m_1m_2 - 2m_1^3 = \frac{2(b-a)(a+b+1)^{3/2}}{(a+b+2)(ab)^{3/2}} \quad (16)$$

For $a > 1, b > 1$

Now deriving the expressions for constants a and b from (15) and (16) in terms of m_1 and m_2 , we get

$$a = \frac{m_1 \{n - (n^2 - 4mp)^{1/2}\}}{2m(1 + m_1)} \quad (17)$$

$$b = \frac{-n + (n^2 - 4mp)^{1/2}}{2m} \quad (18)$$

Where m, n and p have been calculated and given by the formulae,

$$m = 2m_1^4 - 6m_1^2m_2 + 6m_1m_3 \quad (19)$$

$$n = 4m_1^5 + 4m_1^4 - 12m_1^3m_2 - 12m_1^2m_2 + 12m_1^2m_3 + 12m_1m_3 - 4m_1 - 2 \quad (20)$$

$$p = -2m_1^2 - 3m_1 - 1 \quad (21)$$

The Mode i.e. the peak point of the PDF is obtained as [12],

$$Mode = \frac{a-1}{a+b-2} \quad (22)$$

Now the Expression for the Median i.e. 50% delay is given by [13]

$$Median = \frac{1}{3} [Mode + 2Mean] \quad (23)$$

Substituting the values of Mode and Mean from (15) and (21) in (22),

We get

$$Median = \frac{1}{3} \left[\frac{3a^2 + 3ab - 5a - b}{(a+b)(a+b-2)} \right] \quad (24)$$

If we substitute the expressions for a and b from (17) and (18) respectively we get the required expression for Median in terms of first three circuit moments i.e. 50% delay. The final expression is

$$Delay (50\%) = Median = \frac{1}{3} \left[\frac{6m_1(2mp - n^2) - 10m_1m_2(m_1 + 1) + (n^2 - 4mp)^{1/2}(6m_1 + 10m_1^2 + 10m_1m_2)}{2n^2 - 4m(p - n - n_1n) - 2(n^2 - 4mp)(n - 2m - 2m_1n)} \right] \quad (25)$$

By substituting the values of m, n and p ; we can get the closed form expression for Median or 50% Delay in terms of the first three circuit moments.

3.3 Extension for the ramp input

One might assume that the input waveform is a ramp input with slope T , as shown in Fig. 2(a)[13]. The PDF of this waveform is a uniform distribution with mean $\mu(I) = T/2$ and standard deviation $\sigma(I) = \frac{T}{\sqrt{12}}$. Thus, the delay

of the output ramp is as shown in Fig. 2(b).

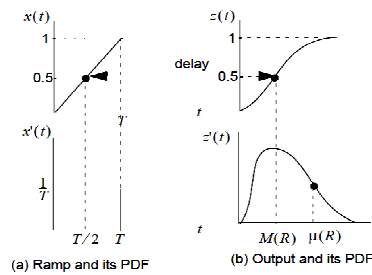

Figure 2. Ramp input and its corresponding response of an RC network

3.3.1 Extended delay Metric for Ramp input

If $\mu(s) = -m_1$ is the Elmore delay and $M(S)$ is the step delay metric as given by equation (25). The delay estimation for the ramp response [13] is given by

$$D(R) = (1-\alpha) \mu(s) + \alpha M(S) \quad (26)$$

Where α denote the constant

$$\alpha = \left(\frac{2m_2 - m_1^2}{2m_2 - m_1^2 + \frac{T^2}{12}} \right)^{\frac{5}{2}} \quad (27)$$

Where $0 < T < \infty$ is the slope of the ramp input as shown in fig-2(a).

From equations (26), we get

$$D(R) = -m_1 + \alpha [m_1 + M(S)]$$

$$D(R) = -m_1 + \alpha \left\{ m_1 + \frac{1}{3} \left[\frac{6n(2mp-n^2) - 10nmkn_1 + (n^2 - 4m)^{3/2} (6n + 10n_1 + 10nm)}{2n^2 - 4n(p-n-n_1) - 2n^2 - 4m(p-n-2m-2n_1)} \right] \right\} \quad (28)$$

The above extended equation (28) is the delay metric equation for the Beta Distribution function for ramp input.

4. Experimental results

We have implemented the proposed delay estimation method using Gamma Distribution and applied it to widely used actual interconnect RC networks as shown in Figure-3. For each RC network source we put a driver, where the driver is a voltage source followed by a resistor.

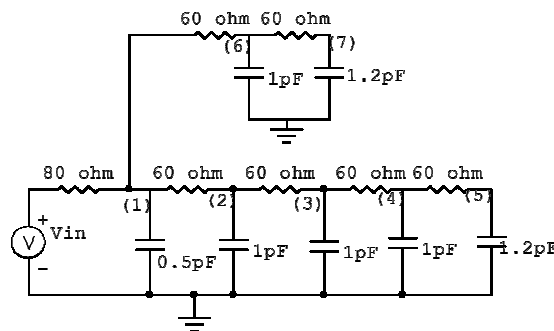

Figure 3. An RC Tree Example

In order to verify the efficiency of our model, we have extracted 208 routed nets containing 1026 sinks from an industrial ASIC design in 0.18 μm technology. We choose the nets so that the maximum sink delay is at least 10 ps and the delay ratio between closet and furthest sinks in the net is less than 0.2. It ensures that each net has at least one near end sink. We classify the 2244 sinks as it was taken in PERI [14] into the following three categories:

- 1187 far-end sinks have delay greater or equal to 75% of the maximum delay to the furthest sink in the net.
- 670 mid-end sinks which have delay between 25% and 75% of the maximum delay and,
- 367 near-end sinks which have delay less than or equal to 25% of the maximum delay.

To find the ramp output delay and slew at node 5, we use a saturate ramp of $T=100$ ps. For both calculation for delay and slew, the relative error is less than 2 %. We compare the obtained average, minimum, maximum

values along with standard deviation for delay from PERI with those found using our proposed model. The comparative results are summarized in Table 1.

Table 1. Delay comparison of our proposed delay model to PERI

Input Slew	250			500		
	PERI	RICE	Proposed Model	PERI	RICE	Proposed Model
1	211	213	210	247	287	273
2	386	385	378	411	410	403
3	489	485	487	506	499	501
4	727	725	711	728	726	721
5	864	879	879	878	889	879
6	473	721	470	486	488	481
7	927	928	931	948	941	943

The comparative result of our proposed model with PERI and RICE [14] are shown in the table 1 and table2.

Table 2. Delay comparison for each node of our proposed delay model to PERI and RICE

Step Delay For Ramp	Delay Metric Using Three Moments							
	PERI Method				Our Proposed Model			
Sinks	Avg	SD	max	min	Avg	SD	max	min
Near	1.39	0.43	2.13	0.48	1.21	0.38	2.11	0.41
Mid	1.24	0.11	1.46	0.93	1.11	0.09	1.36	0.89
Far	1.01	0.82	1.07	0.98	1.05	0.87	1.04	0.91
Total	1.07	0.15	2.32	0.50	1.03	0.12	1.62	0.53

6. Conclusion

In this paper we have extended an proposed efficient and accurate interconnect delay metric for high speed VLSI designs from step input to ramp input. We have used Gamma probability distribution function to derive our metric. Our model has Elmore delay as upper bound but with significantly less error. The novelty of our approach is justified by the calculated the comparison made with that of the results obtained by SPICE simulations.

References

- W.C.Elmore, "The transient response of damped Linear network with Particular regard to Wideband Amplifiers", *J. Applied Physics*, 19, 1948, pp.55-63.
- R.Kay and L.Pileggi, "PRIMO: Probability Interpretation of Moments for Delay Calculation", *IEEWACM Design Automation Conference*, 1998, pp. 463-468.
- Shien-Yang Wu, Boon-Khim Liew, K.L. Young, C.H.Yu, and S.C"Analysis of Interconnect Delay for 0.18 μ m Technology and Beyond" *IEEE International Conference Interconnect Technology*, May 1999 , pp. 68 - 70
- T. Lin, E. Acar, and L. Pileggi, "h-gamma: An RC Delay Metric Based on a Gamma Distribution Approximation to the Homogeneous Response", *IEEE/ACM International Conference on Computer-Aided Design*, 1998, pp. 19-25.
- L. T. Pillage and R. A. Rohrer, "Asymptotic Waveform Evaluation for Timing Analysis", *Tran. on CAD*, Volume 9, Issue 4, 1990. pp. 331- 349
- R. Gupta, B. Tutuianu, and L. T. Pileggi, "The Elmore Delay as a Bound for RC Trees with Generalized Input Signals", *IEEE Trans. on CAD*, 16(1), pp. 95-104, 1997.
- H. J. Larson, "Introduction to Probability Theory and Statistical Inference", 3rd ed., John Wiley & Sons pub., 1982.
- M. G. Kendall and A. Stuart, "The Advanced Theory of Statistics, vol. 1: Distribution Theory", New York: Hafner, 1969.
- H. L MacGillivray, "The Mean, Median, Mode Inequality and Skewness for a Class of Densities", *Australian J. of Statistics*, vol. 23 no. 2, 1981.
- C. Chu and M. Horowitz, Charge-Sharing Models for Switch Level Simulation, *Trans. on CAD*, Volume 6, Issue 6 June, 1987.
- Harald Cramer. *Mathematical Methods of Statistics*. Princeton University Press, 1946.
- M. Celik, L. Pileggi, A. Odabasioglu, "IC Interconnect Analysis" by Kluwer Academic Publishers, 2002.

Chandramouli V. Kashyap, Charles J. Alpert, Frank Liu, and Anirudh Devgan, “PERI: A Technique for Extending Delay and Slew Metrics to Ramp Inputs” Proceedings of the 8th ACM/IEEE international workshop on Timing issues in the specification and synthesis of digital systems 2002, pp. 57 – 62

Chandramouli V. Kashyap, Charles J. Alpert, Frank Liu, and Anirudh Devgan, “Closed Form Expressions for Extending Step Delay and Slew Metrics to Ramp Inputs”, International Symposium on Physical Design archive Proceedings of the 2003 ,Pages: 24 - 31